



BITSAT 2026 April 16 (Shift-2)

Question Paper (Memory-Based) PDF

Conducted by BITS Pilani

General Instructions

- (i) **Duration:** The total duration of the examination is 3 hours (180 minutes).
- (ii) **Total Marks:** The complete paper carries a maximum of 390 marks.
- (iii) **Structure:** The paper has 4 Sections:
 - **Part 1:** 30 Multiple Choice Questions (Physics).
 - **Part 2:** 30 Multiple Choice Questions (Chemistry).
 - **Part 3:** 10 Multiple Choice Questions (English Proficiency),
20 Multiple Choice Questions (Logical Reasoning)
 - **Part 4:** 40 Multiple Choice Questions (Mathematics/Biology)
- (iv) **Compulsory Questions:** All 130 questions are compulsory, and +12 Questions (Optional Extra Questions)
- (v) Each question has four options. Only **one** option is correct.
- (vi) **Correct Answer:** +3 marks.
- (vii) **Incorrect Answer:** -1 (Negative marking).
- (viii) **Unanswered/Marked for Review:** 0 marks.

PHYSICS

1. The combination of the gates shown in the following figure yields

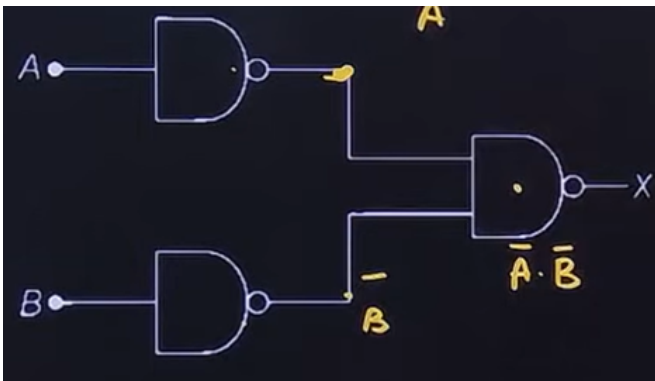

- (a) NAND gate
- (b) OR gate
- (c) NOT gate
- (d) XOR gate

2. A series LCR circuit consists of $R = 80 \Omega$, $X_L = 100 \Omega$, and $X_C = 40 \Omega$. The input voltage is $2500 \cos(100\pi t)$ V. The amplitude of current in the circuit is

- (a) 25 A
- (b) 50 A
- (c) 75 A
- (d) 100 A

3. The critical angle of a medium for a specific wavelength, if the medium has relative permittivity 3 and relative permeability $\frac{4}{3}$ for this wavelength, will be:

- (a) 15°
- (b) 30°
- (c) 45°
- (d) 60°

4. Two lighter nuclei combine to form a comparatively heavier nucleus by the relation

$$\frac{2}{1}\text{X} + \frac{2}{1}\text{X} = \frac{4}{2}\text{Y}$$

The binding energies per nucleon of ${}^2_1\text{X}$ and ${}^4_2\text{Y}$ are 1.1 MeV and 7.6 MeV respectively. The energy released in this process is

- (a) 26 MeV
- (b) 56 MeV
- (c) 78 MeV
- (d) 108 MeV

5. A given ray of light suffers minimum deviation in an equilateral prism P. Additional prisms Q and R of identical shape and of same material as that of P are now combined as shown in the figure. The ray will now suffer

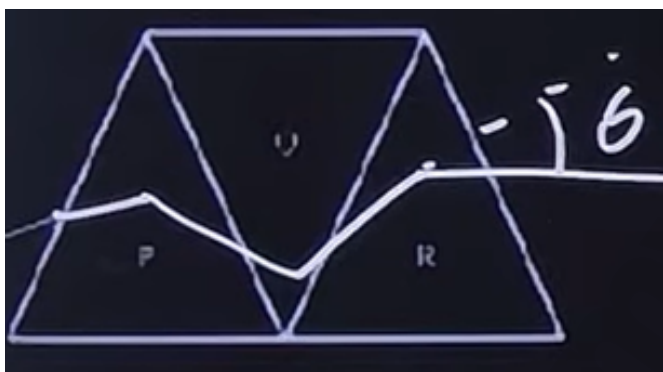

- (a) greater deviation
- (b) no deviation
- (c) same deviation as before
- (d) total internal reflection

CHEMISTRY

6. Which of the following gases has the highest rate of diffusion?

- (A) O_2
- (B) CO_2
- (C) H_2

(D) N_2

7. What is the IUPAC name of the compound: $CH_3 - CH_2 - CH(CH_3) - CH_2 - CH_3$

- (A) 3-Methylpentane
 - (B) 2-Methylpentane
 - (C) 3-Methylbutane
 - (D) 2-Methylbutane
-

8. A first-order reaction is 25% complete in 30 minutes. How much time will it take for the reaction to be 75% complete?

- (A) 90 min
 - (B) 60 min
 - (C) 120 min
 - (D) 150 min
-

9. Which of the following substances does not undergo hydrolysis in aqueous solution?

- (A) Sodium acetate
 - (B) Ammonium chloride
 - (C) Sodium carbonate
 - (D) Sodium chloride
-

10. How many moles of oxygen are required to completely combust 1 mole of propane (C_3H_8)?

- (A) 4 moles
 - (B) 5 moles
 - (C) 6 moles
 - (D) 3 moles
-

MATHEMATICS

11. The area of the region bounded by the curves $x = y^2 - 2$ and $x = y$ is

- (A) $\frac{9}{4}$
 - (B) 9
 - (C) $\frac{9}{2}$
 - (D) $\frac{9}{7}$
-

12. The value of $\int e^{\tan \theta} (\sec \theta - \sin \theta) d\theta$ is

- (A) $e^{\tan \theta} \sec \theta + c$
 - (B) $e^{\tan \theta} \sin \theta + c$
 - (C) $e^{\tan \theta} (\sec \theta + \sin \theta) + c$
 - (D) $e^{\tan \theta} \cos \theta + c$
-

13. If $\vec{a} = 2\hat{i} + \hat{j} + 2\hat{k}$, then the value of $|\hat{i} \times (\vec{a} \times \hat{i})|^2 + |\hat{j} \times (\vec{a} \times \hat{j})|^2 + |\hat{k} \times (\vec{a} \times \hat{k})|^2$ is equal to

- (A) 17
 - (B) 18
 - (C) 19
 - (D) 20
-

14. The magnitude of projection of line joining (3, 4, 5) and (4, 6, 3) on the line joining (1, 2, 4) and (1, 0, 5) is

- (A) $\frac{4}{3}$
 - (B) $\frac{2}{3}$
 - (C) $\frac{8}{3}$
 - (D) $\frac{1}{3}$
-

15. Let the foot of perpendicular from a point $P(1, 2, -1)$ to the straight line $L : \frac{x}{1} = \frac{y}{0} = \frac{z}{-1}$ be N . Let a line be drawn from P parallel to the plane $x + y + 2z = 0$ which meets L at point Q . If α is the acute angle between the lines PN and PQ , then $\cos \alpha$ is equal to

- (A) $\frac{1}{\sqrt{5}}$
 - (B) $\frac{\sqrt{3}}{2}$
 - (C) $\frac{1}{\sqrt{3}}$
 - (D) $\frac{1}{2\sqrt{3}}$
-