

BM: Biomedical Engineering
GA - General Aptitude

Q1 - Q5 carry one mark each.

Q.No. 1 Rajiv Gandhi Khel Ratna Award was conferred_____Mary Kom, a six-time world champion in boxing, recently in a ceremony_____the Rashtrapati Bhawan (the President's official residence) in New Delhi.

- (A) with, at
- (B) on, in
- (C) on, at
- (D) to, at

Q.No. 2 Despite a string of poor performances, the chances of K. L. Rahul's selection in the team are_____.

- (A) slim
- (B) bright
- (C) obvious
- (D) uncertain

Q.No. 3 Select the word that fits the analogy:

Cover : Uncover :: Associate : _____

- (A) Unassociate
- (B) Inassociate
- (C) Misassociate
- (D) Dissociate

Q.No. 4 Hit by floods, the kharif (summer sown) crops in various parts of the country have been affected. Officials believe that the loss in production of the kharif crops can be recovered in the output of the rabi (winter sown) crops so that the country can achieve its food-grain production target of 291 million tons in the crop year 2019-20 (July-June). They are hopeful that good rains in July-August will help the soil retain moisture for a longer period, helping winter sown crops such as wheat and pulses during the November-February period.

Which of the following statements can be inferred from the given passage?

- (A) Officials declared that the food-grain production target will be met due to good rains.
- (B) Officials want the food-grain production target to be met by the November-February period.
- (C) Officials feel that the food-grain production target cannot be met due to floods.
- (D) Officials hope that the food-grain production target will be met due to a good rabi produce.

Q.No. 5 The difference between the sum of the first $2n$ natural numbers and the sum of the first n odd natural numbers is _____.

- (A) $n^2 - n$
- (B) $n^2 + n$
- (C) $2n^2 - n$
- (D) $2n^2 + n$

Q6 - Q10 carry two marks each.

Q.No. 6 Repo rate is the rate at which Reserve Bank of India (RBI) lends commercial banks, and reverse repo rate is the rate at which RBI borrows money from commercial banks.

Which of the following statements can be inferred from the above passage?

- (A) Decrease in repo rate will increase cost of borrowing and decrease lending by commercial banks.
- (B) Increase in repo rate will decrease cost of borrowing and increase lending by commercial banks.
- (C) Increase in repo rate will decrease cost of borrowing and decrease lending by commercial banks.
- (D)

Decrease in repo rate will decrease cost of borrowing and increase lending by commercial banks.

- Q.No. 7 P, Q, R, S, T, U, V, and W are seated around a circular table.
- I. S is seated opposite to W.
 - II. U is seated at the second place to the right of R.
 - III. T is seated at the third place to the left of R.
 - IV. V is a neighbour of S.

Which of the following must be true?

- (A) P is a neighbour of R.
- (B) Q is a neighbour of R.
- (C) P is not seated opposite to Q.
- (D) R is the left neighbour of S.

- Q.No. 8 The distance between Delhi and Agra is 233 km. A car P started travelling from Delhi to Agra and another car Q started from Agra to Delhi along the same road 1 hour after the car P started. The two cars crossed each other 75 minutes after the car Q started. Both cars were travelling at constant speed. The speed of car P was 10 km/hr more than the speed of car Q . How many kilometers the car Q had travelled when the cars crossed each other?

- (A) 66.6
- (B) 75.2
- (C) 88.2
- (D) 116.5

- Q.No. 9 For a matrix $M = [m_{ij}]$; $i, j = 1, 2, 3, 4$, the diagonal elements are all zero and $m_{ij} = -m_{ji}$. The minimum number of elements required to fully specify the matrix is _____.

- (A) 0
- (B) 6
- (C) 12
- (D) 16

- Q.No. 10 The profit shares of two companies P and Q are shown in the figure. If the two companies have invested a fixed and equal amount every year, then the ratio of the total revenue of company P to the total revenue of company Q, during 2013 - 2018 is _____.

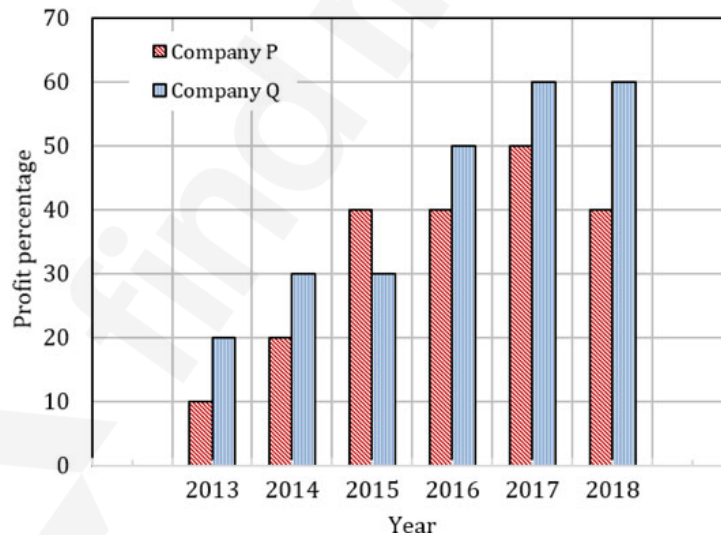

- (A) 15 : 17
- (B) 16 : 17
- (C) 17 : 15
- (D) 17 : 16

BM: Biomedical Engineering

Q1 - Q25 carry one mark each.

- Q.No. 1

m_1 and m_2 are the roots of the characteristic equation of a linear second order physical system. Match the nature of the roots with the natural response of the system.

Nature of roots		System response	
P	m_1 and m_2 are real and distinct	K	Critically damped
Q	m_1 and m_2 are equal	L	Overdamped
R	m_1 and m_2 are complex	M	Underdamped

- (A) P-L, Q-M, R-K
 (B) P-M, Q-L, R-K
 (C) P-L, Q-K, R-M
 (D) P-M, Q-K, R-L

Q.No. 2 A person is sitting in a chair with feet on the ground. While rising up on his feet, the kinematic motion NOT occurring is

- (A) Hip extension
 (B) Plantar flexion
 (C) Hip flexion
 (D) Knee extension

Q.No. 3 The equipment that measures elasticity of blood vessel *in vivo* is

- (A) Rheometer
 (B) Dimension analyser
 (C) Thermomechanical analyser
 (D) Dynamic mechanical analyser

Q.No. 4 Biomaterials with shape memory effects are NOT used in

- (A) Intracranial aneurysm clips
 (B) Arterial blood vessel closure devices
 (C) Orthopedic total joint replacements
 (D) Orthodontic dental arch wires

Q.No. 5 The MRI scanner parameter of long T_{Rep} or short T_{Echo} will generate a _____ contrast image

- (A) Proton Density -weighted
 (B) T2- weighted
 (C) T1- weighted
 (D) T2* - weighted

Q.No. 6 In diagnostic X-ray imaging, the following is NOT a part of primary EM radiation interaction in soft tissue.

- (A) Photoelectric effect
 (B) Characteristic radiation production
 (C) Compton scattering
 (D) Pair-production

Q.No. 7 A 5 MHz ultrasound pulse is used to image a tumor at a depth of 2 cm in a soft tissue. It takes time t for the reflected echo from the tumor to come back to the receiver. Instead, if a 2.5 MHz wave is used, how long will it take for the echo from the same tumor to arrive at the receiver?

- (A) $t/2$
 (B) t
 (C) $2t$
 (D) $4t$

Q.No. 8

$X(s)$ is the Laplace transform of a signal $x(t)$.

The Laplace transform of $\frac{dx(t)}{dt}$, assuming $x(0) = 0$, is

- (A) $sX(s)$
- (B) $X(s)/s$
- (C) $\frac{dX(s)}{ds}$
- (D) $\frac{1}{s} \frac{dX(s)}{ds}$

Q.No. 9 Which of the following are odd functions?

P: $\sin(t)$

Q: $\cos(t)$

R: $\sin(t) + \cos(t)$

S: $\sin(t)\cos(t)$

- (A) Q and S
- (B) P and Q
- (C) P and S
- (D) R and Q

Q.No. 10 State-space model of a system is given as:

$$\dot{X} = \begin{bmatrix} 0 & 2 \\ a & 0 \end{bmatrix} X + \begin{bmatrix} b \\ 0 \end{bmatrix} U$$

$$Y = [1 \quad 0]X$$

The conditions for the system to be controllable are

- (A) $a = 0, b \neq 0$
- (B) $a \neq 0, b = 0$
- (C) $a \neq 0, b \neq 0$
- (D) $a = 0, b = 0$

Q.No. 11 In microprocessor systems with memory mapped I/O, which of the following is true?

- (A) Only I/O devices with internal memory can be interfaced.
- (B) I/O devices can be accessed using IN and OUT instructions
- (C) Each I/O device can be addressed as a memory location
- (D) Arithmetic and logic operations cannot be directly performed with the I/O data

Q.No. 12 The number of electrodes used in recording standard 12-lead Electrocardiogram (ECG) is

- (A) 13
- (B) 12
- (C) 11
- (D) 10

Q.No. 13 Which of the following is NOT a part of knee joint?

- (A) Patella
- (B) Tibia
- (C) Femur
- (D) Fibula

Q.No. 14 During a routine stethoscopic examination at the left midclavicular-5th intercostal space, murmurs were noted between first and second heart sound. The possible abnormality among the following could be

- (A) Aortic stenosis

- (B) Mitral regurgitation
 (C) Mitral stenosis
 (D) Aortic regurgitation

- Q.No. 15 The thin filament of a muscle fiber is comprised of
 (A) Troponin, Tropomyosin, Actin
 (B) Troponin, Tropomyosin, Titin
 (C) Tropomyosin, Titin, Actin
 (D) Actin, Myosin, Troponin

- Q.No. 16 The value of the integral evaluated over the contour C: $|z| = 3/2$ is _____

$$\frac{1}{2\pi j} \oint \frac{z}{(z-1)(z-2)} dz$$

- Q.No. 17 The eigenvalues of a 3×3 non-singular matrix P are 1, 2 and 3. The trace of matrix P^{-1} (rounded off to two decimal places) is _____
- Q.No. 18 The following recursion relation, when started from a finite positive non-zero value, converges to _____

$$x_{n+1} = \frac{1}{2} \left(x_n + \frac{1}{x_n} \right)$$

- Q.No. 19 In a nuclear imaging system, Sodium Iodide (NaI) crystals are used to detect gamma rays of 120 keV. The percentage (%) of gamma-rays that will pass through 1 cm of NaI crystal, assuming the Half-Value-Layer (HVL) of NaI as 0.2 cm, is _____ (rounded off to one decimal place).
- Q.No. 20 The distal end of an endoscope is placed at a distance of 1 mm from the gastrointestinal wall. The refractive indices of the fiber core and cladding are 1.5 and 1.45, respectively.

The maximum field of view for the endoscope is _____ degrees (rounded off to one decimal place).
- Q.No. 21 Two inductors with the details given below are wound separately on two identical ring type ferromagnetic cores.

Coil	Number of turns	Gauge of wire	Self-Inductance
Coil-1	N	G	L_1
Coil-2	2N	G/2	L_2

The ratio L_2/L_1 is _____.

- Q.No. 22 Two dyes X and Y having concentrations in the ratio 0.25 in identical cuvettes were subjected to absorption measurements in a spectrophotometer. The estimated ratio of their absorbance is 0.5. The ratio of their molar extinction coefficients is _____.
- Q.No. 23 Hydrolysis of one ATP molecule provides an energy of _____ kilo calories (correct up to one decimal place).

- Q.No. 24 An 830 nm laser Doppler flow meter probe is oriented at an angle of 60° to the flow axis. If the average flow velocity is 3 cm/s, the magnitude of Doppler shift frequency (kHz) is _____ (rounded off to one decimal place).
- Q.No. 25 A 100 mA single current pulse from a pulse generator is used for artificial pacing of heart at the right ventricle. If the delivered energy does not exceed the fibrillation threshold of $300 \mu\text{J}$, the safe duration of the pulse that could be applied to the tissue mass having an impedance of 500Ω is _____ μs .

Q26 - Q55 carry two marks each.

- Q.No. 26 The resting potential of a mammalian nerve cell is -80 mV . A certain drug administered to the body changes the intracellular K^+ concentration from 150 mmol/L to 55 mmol/L. The nearest value of cell membrane potential after the drug administration, assuming that the external equilibrium of K^+ does not get changed during the event, is

(Gas constant = 8.315 J/mol/K , core temperature = 37° C and

Faraday constant = 96500 C/mol)

- (A) -117 mV
 (B) -18.71 mV
 (C) -53.32 mV
 (D) -141.30 mV

- Q.No. 27 The arrangement of four resistors of equal value in the diaphragm of a physiological pressure measurement catheter is shown below. The applied pressure is observed to cause an increase in length of resistors R2, R4 and an increase in cross sectional area in R1 and R3. The operation results in an equal change in the values of all four resistors. Which among the configuration given below should be used to connect the resistors to form a Wheatstone bridge so that bridge output voltage is proportional to the change in resistance of individual resistors?

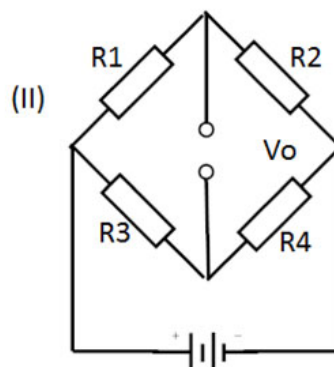
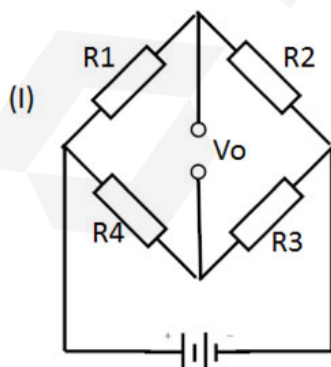
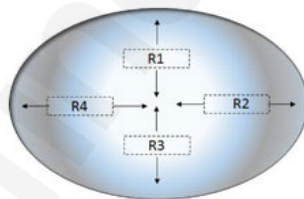

- (A) I only
 (B) II only
 (C) Neither I nor II
 (D) Both I and II

- Q.No. 28

For the given input voltage, $V_{in} = 10 \sin(2\pi t)$ to the functional circuit shown below, the output signal will be

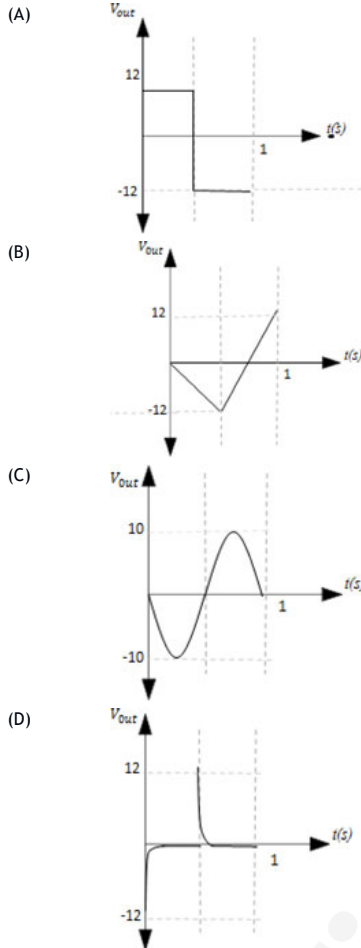
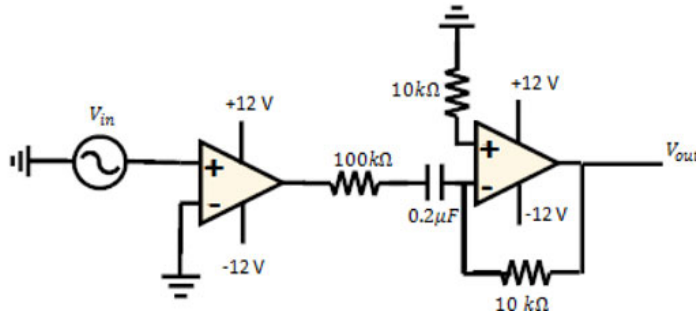

- Q.No. 29 During a non-invasive measurement of blood pressure, mean arterial pressure was observed to be 100 mm Hg. If systolic pressure is 150 mm Hg, the diastolic pressure would be
- (A) 110 mm Hg
 (B) 75 mm Hg
 (C) 70 mm Hg
 (D) 50 mm Hg

Q.No. 30

Two loads are connected to AC supply mains as depicted in the figure. One load draws 10 kW whereas the other load of 10 kVA is operated at 0.6 pf lagging. To achieve an overall power factor of 0.9544 lagging, the nearest kVAr rating of the capacitor bank needed to be connected across the supply mains is equal to

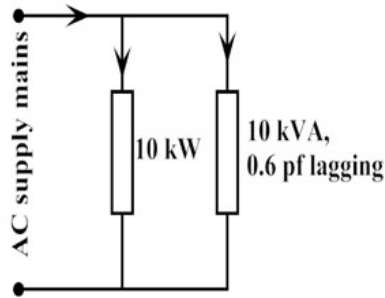

- (A) 3
- (B) 5
- (C) 7
- (D) 9

Q.No. 31 The nearest value of power dissipated in the $3\ \Omega$ resistance in the circuit is

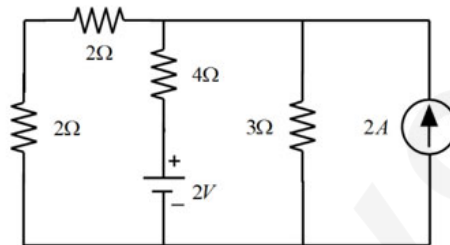

- (A) 3 W
- (B) $25/3$ W
- (C) 12 W
- (D) $25/12$ W

Q.No. 32 A second order low pass filter is being constructed by cascading two first order low pass filters with the following transfer functions

$$H_1(j\omega) = \frac{1}{1+j\omega/\omega_1}, \quad H_2(j\omega) = \frac{1}{1+j\omega/\omega_2}$$

where ω_1 and ω_2 are the respective 3dB cut off frequencies.

The undamped natural frequency ω_c of the resulting second order low pass filter is

- (A) $\omega_c = \sqrt{\omega_1\omega_2}$
- (B) $\omega_c = \omega_1 + \omega_2$
- (C) $\omega_c = \frac{\omega_1\omega_2}{\omega_1 + \omega_2}$
- (D) $\omega_c = \sqrt{\omega_1^2 + \omega_2^2}$

Q.No. 33

Match the bridge type with the application given below:

	Name of the bridge		Application
P	Maxwell bridge	K	Measurement of Low resistance
Q	Kelvin double bridge	L	Measurement of medium Q-coil inductance
R	Hay bridge	M	Measurement of capacitance
S	Schering bridge	N	Measurement of High Q-coil inductance

- (A) P-L, Q-K, R-N, S-M
 (B) P-N, Q-K, R-L, S-M
 (C) P-N, Q-L, R-M, S-K
 (D) P-L, Q-M, R-N, S-K

Q.No. 34 For a non-unity feedback system with $G(s) = \frac{12}{s+2}$ and $H(s) = \frac{2}{s+3}$,

the magnitude of steady-state error to a unit step-input is

- (A) 0.50
 (B) 0.45
 (C) 0.25
 (D) 0.20

Q.No. 35 Match the Boolean expression with its minimal realization

	Boolean expression		Minimal realization
P	$\bar{X}\bar{Y}\bar{Z} + \bar{X}YZ + \bar{X}YZ$	K	$X(Y + Z)$
Q	$XYZ + X\bar{Y}Z + XY\bar{Z}$	L	$\bar{X}(Y + \bar{Z})$
R	$XY + XYZ + XY\bar{Z} + \bar{X}YZ$	M	Z
S	$\bar{X}\bar{Y}Z + \bar{X}YZ + X\bar{Y}Z + XYZ$	N	$Y(X + Z)$

- (A) P-K, Q-L, R-N, S-M
 (B) P-L, Q-K, R-N, S-M
 (C) P-L, Q-N, R-M, S-K
 (D) P-M, Q-K, R-L, S-N

Q.No. 36 The glomerulus filtration process of kidney is modeled as a flat membrane with pores of radius 1 nm and length of pore 60 nm. The viscosity of the fluid is 0.002 Pa s. The aggregate area of the pores makeup 5% of total surface area of the membrane. The average pressure on the blood side of the membrane is 8000 Pa and on the ultrafiltrate side is 6200 Pa. The total available area of membrane is 1.5 m^2 . The nearest value of resulting filtration rate in cm^3/min is

- (A) 0.14
 (B) 1.40
 (C) 8.43
 (D) 84.37

Q.No. 37

During resting state, the voltage outside the cell membrane compared to that inside the membrane is _____. Under such conditions, the intracellular and extracellular regions have _____ and _____ concentrations, respectively.

- (A) More positive, more Potassium [K⁺], more Sodium [Na⁺]
- (B) More negative, more Potassium [K⁺], more Sodium [Na⁺]
- (C) More negative, more Sodium [Na⁺], more Potassium [K⁺]
- (D) More positive, more Sodium [Na⁺], more Potassium [K⁺]

Q.No. 38 The tensile strength of a degradable suture used for a surgical procedure in the human body is observed to decrease exponentially from its original strength by 40% and 50% after 10 days and 20 days, respectively. The closest approximation of the time taken for the tensile strength to decay to 20% of its original value

would be

- (A) 35 days
- (B) 45 days
- (C) 60 days
- (D) 70 days

Q.No. 39 A 60 kg person is standing on one foot on a force plate. The ground reaction force is found to act 40 mm anterior to the ankle joint. The mass center of a foot is 60 mm from the Trochanter Knee Ankle (TKA) line. If the weight of the foot is 0.8 kg, the closest value of **magnitude** of moment acting on the ankle joint is

- (A) 23 Nm
- (B) 48 Nm
- (C) 235 Nm
- (D) 466 Nm

Q.No. 40 The temperature of bone cement is increased from 37°C to 87°C during the femoral hip arthroplasty. The cement thickness is noted to be 20 mm. The stress developed due to exothermic reaction of bone cement during the polymerization process and shrinkage of the bone cement, respectively, are

Assume that

- (i) bone, cement, and implant are modeled as a set of concentric cylinders
- (ii) no direct adhesion takes place between bone and cement
- (iii) temperature is uniform

Coefficient of thermal expansion of bone cement = $90 \times 10^{-6}/^{\circ}\text{C}$

Young's modulus of bone cement = 3.5 GPa

- (A) 15.75 MPa, 90 μm
- (B) 15.75 MPa, 110 μm
- (C) 6.85 MPa, 110 μm
- (D) 6.85 MPa, 90 μm

Q.No. 41

A patient is initially imaged in a 1 Tesla MRI scanner and induced voltage is found to be equal to V_1 . The expression for the magnitude of the received voltage in RF coil is given below.

$$|V| = 2\pi\gamma_0 V_S M_0 (\sin\alpha) \beta^r$$

V_S : MR slice volume, M_0 : Magnitude of resultant magnetic vector at equilibrium, γ_0 : Larmor frequency, α : tip angle, β^r : Magnetic field sensitivity of receive coil.

When the patient is shifted to a 3 Tesla MRI scanner that uses the same RF coil and the slice thickness is halved, the magnitude of the induced voltage was found to be equal to V_2 . The ratio V_2/V_1 is

- (A) 1.5
- (B) 3.0
- (C) 4.5
- (D) 6.0

Q.No. 42 A 3 MHz ultrasound transducer transmits a 3-cycle long pulse into a soft tissue at normal incidence to fat and liver interface. The axial resolution (mm) and the amplitude reflection coefficient at fat-liver interface, respectively, are

Use $C_{tissue} = 1500$ m/s, $C_{fat} = 1450$ m/s, $C_{liver} = 1570$ m/s,

$\rho_{fat} = 920$ kg/m³, $\rho_{liver} = 1060$ kg/m³

- (A) 0.5, 0.22
- (B) 0.75, 0.22
- (C) 0.5, 0.11
- (D) 0.75, 0.11

Q.No. 43 The forward biased current of a silicon (Si) diode is being calculated from the exponential model of the V-I characteristics. If the diode current $I_D = 1$ mA at a voltage drop $V_D = 0.7$ V, the nearest value of I_D when $V_D = 0.8$ V is

Assume thermal voltage $V_T = 25.3$ mV for Si diode

- (A) 0.133 mA
- (B) 2 mA
- (C) 52 mA
- (D) 90 mA

Q.No. 44 A continuous random variable x has a probability density function given by

$$f(x) = e^{-\alpha|x|} \quad (-\infty < x < \infty)$$

where α is a real constant. The variance of x is _____ (correct up to one decimal place).

Q.No. 45 The magnitude of the gradient of the function $f(x, y) = x^2 + y^2$ at the point (1,1) is _____ (rounded off to two decimal places).

Q.No. 46 The value of following double integral is _____ (correct up to three decimal places).

$$\iint_R xy \, dx dy$$

where R is the first quadrant of the circle with center at the origin and radius of one unit.

- Q.No. 47 A gynaecologist recorded the blood pressure (BP) of patients as shown in the Table below. Using Regression process, the diastolic BP of a 38 year old patient (mm Hg) is _____ (rounded off to two decimal places).

Age (years)	23	24	25	26	28	29	31	35	40
BP (diastolic) mm Hg	65	60	62	70	70	73	75	83	90

- Q.No. 48 A person in standing position first flexes the hip by 50° from the initial Trochanter knee ankle (TKA) line and then flexes knee by 20° . The distance of ankle joint from the initial TKA line is _____ (rounded off to nearest integer).
- the distance between hip joint and knee joint is 400 mm
 - the distance between knee joint and ankle joint is 300 mm.
- Q.No. 49 A chest radiograph of $36\text{ cm} \times 48\text{ cm}$ is digitized. If we want to preserve details in the image to a spatial resolution of 6 cycles/mm, the approximate image data size in MB for an 8 bit quantization is _____ (rounded off to two decimal places).
- Q.No. 50 An X-ray radiography scenario is shown in the figure. If the number of incident photons (N_i) is equal to 2×10^6 at 50 keV, the number of photons (N_d) that exit the tissue is _____ $\times 10^6$ (rounded off to two decimal places).

(use linear attenuation coefficient for soft tissue and blood at 50 keV as 0.4 cm^{-1} and 0.2 cm^{-1} , respectively).

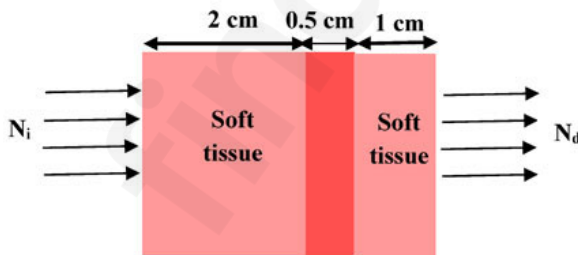

- Q.No. 51 The wavelength of an electron accelerated to a potential of 1V is _____ nm (rounded off to two decimal places).

$$\text{Mass of electron} = 9.11 \times 10^{-31}\text{ kg}$$

$$\text{Planck's constant, } h = 6.63 \times 10^{-34}\text{ Js}$$

$$\text{Charge of electron} = 1.6 \times 10^{-19}\text{ C}$$

- Q.No. 52

In a permanent magnetic moving coil (PMMC) instrument having following specifications, the angular deflection of the pointer for a coil current of $100 \mu\text{A}$ will be _____ degrees (rounded off to one decimal place).

Magnetic flux density = 1.5 Tesla

Torsional spring constant = 2×10^{-6} Nm/deg

Cross sectional area of the coil = 2.5 cm^2

Number of turns of the coil = 500

Q.No. 53 Arterial blood extracted from a healthy adult showed an oxygen partial pressure value of 40 mm Hg. The total oxygen content in the arterial blood measured in %V/V is _____ (rounded off to one decimal place).

Given: Solubility of oxygen in blood = 0.003 ml/mm Hg/dL

Hemoglobin oxygen saturation = 95 %

Oxygen carrying capacity of Hb = 1.34 ml/g

Arterial blood hemoglobin concentration = 15g/dL

Q.No. 54 In the process of measuring blood flow from an artery using C-clamp magnetic flow probe, the voltage recorded across diametrically opposite sites of the artery is 3.75 nV. The blood flow rate through the artery is _____ cm^3/s (rounded off to two decimal places).

The inner diameter of the C-clamp = 0.5 cm,

The magnetic flux density = 1.5×10^{-5} Wb/m².

Q.No. 55 A cell is injected with a current $i(t) = u(t)$ to produce a change in the intracellular membrane voltage $v(t)$. The cell-membrane is modeled as a linear system with impulse response $h(t) = A e^{-\frac{t}{\tau}} u(t)$. The cell membrane voltage output at 5 ms is _____ mV.

Use $A = -34 \text{ V/s}$; $\tau = 3 \text{ ms}$.