

XE: Engineering Sciences

GA - General Aptitude

Q1 - Q5 carry one mark each.

Q.No. 1 Rajiv Gandhi Khel Ratna Award was conferred_____Mary Kom, a six-time world champion in boxing, recently in a ceremony_____the Rashtrapati Bhawan (the President's official residence) in New Delhi.

- (A) with, at
- (B) on, in
- (C) on, at
- (D) to, at

Q.No. 2 Despite a string of poor performances, the chances of K. L. Rahul's selection in the team are_____.

- (A) slim
- (B) bright
- (C) obvious
- (D) uncertain

Q.No. 3 Select the word that fits the analogy:

Cover : Uncover :: Associate : _____

- (A) Unassociate
- (B) Inassociate
- (C) Misassociate
- (D) Dissociate

Q.No. 4 Hit by floods, the kharif (summer sown) crops in various parts of the country have been affected. Officials believe that the loss in production of the kharif crops can be recovered in the output of the rabi (winter sown) crops so that the country can achieve its food-grain production target of 291 million tons in the crop year 2019-20 (July-June). They are hopeful that good rains in July-August will help the soil retain moisture for a longer period, helping winter sown crops such as wheat and pulses during the November-February period.

Which of the following statements can be inferred from the given passage?

- (A) Officials declared that the food-grain production target will be met due to good rains.
- (B) Officials want the food-grain production target to be met by the November-February period.
- (C) Officials feel that the food-grain production target cannot be met due to floods.
- (D) Officials hope that the food-grain production target will be met due to a good rabi produce.

Q.No. 5 The difference between the sum of the first $2n$ natural numbers and the sum of the first n odd natural numbers is _____.

- (A) $n^2 - n$
- (B) $n^2 + n$
- (C) $2n^2 - n$
- (D) $2n^2 + n$

Q6 - Q10 carry two marks each.

Q.No. 6 Repo rate is the rate at which Reserve Bank of India (RBI) lends commercial banks, and reverse repo rate is the rate at which RBI borrows money from commercial banks.

Which of the following statements can be inferred from the above passage?

- (A) Decrease in repo rate will increase cost of borrowing and decrease lending by commercial banks.
- (B) Increase in repo rate will decrease cost of borrowing and increase lending by commercial banks.
- (C) Increase in repo rate will decrease cost of borrowing and decrease lending by commercial banks.
- (D)

Decrease in repo rate will decrease cost of borrowing and increase lending by commercial banks.

- Q.No. 7 P, Q, R, S, T, U, V, and W are seated around a circular table.
- I. S is seated opposite to W.
 - II. U is seated at the second place to the right of R.
 - III. T is seated at the third place to the left of R.
 - IV. V is a neighbour of S.

Which of the following must be true?

- (A) P is a neighbour of R.
- (B) Q is a neighbour of R.
- (C) P is not seated opposite to Q.
- (D) R is the left neighbour of S.

- Q.No. 8 The distance between Delhi and Agra is 233 km. A car P started travelling from Delhi to Agra and another car Q started from Agra to Delhi along the same road 1 hour after the car P started. The two cars crossed each other 75 minutes after the car Q started. Both cars were travelling at constant speed. The speed of car P was 10 km/hr more than the speed of car Q . How many kilometers the car Q had travelled when the cars crossed each other?

- (A) 66.6
- (B) 75.2
- (C) 88.2
- (D) 116.5

- Q.No. 9 For a matrix $M = [m_{ij}]$; $i, j = 1, 2, 3, 4$, the diagonal elements are all zero and $m_{ij} = -m_{ji}$. The minimum number of elements required to fully specify the matrix is _____.

- (A) 0
- (B) 6
- (C) 12
- (D) 16

- Q.No. 10 The profit shares of two companies P and Q are shown in the figure. If the two companies have invested a fixed and equal amount every year, then the ratio of the total revenue of company P to the total revenue of company Q, during 2013 - 2018 is _____.

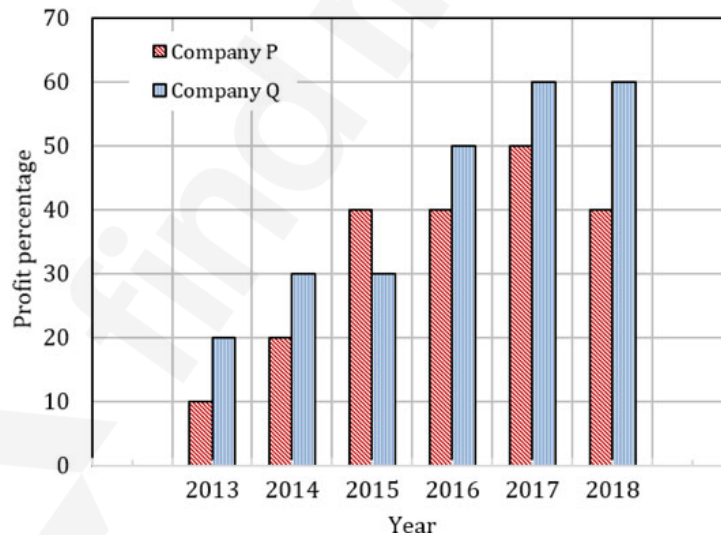

- (A) 15 : 17
- (B) 16 : 17
- (C) 17 : 15
- (D) 17 : 16

XE: Engineering Sciences - A: Engineering Mathematics (compulsory)

Q1 - Q7 carry one mark each.

- Q.No. 1 Let A be a 4×3 non-zero matrix and let b be a 4×1 column vector. Then $Ax = b$ has
- (A) a solution for every b .
 - (B) no solution for some b .
 - (C) a solution only when $b = 0$.

(D) a solution if b and the columns of A form a linearly independent set.

Q.No. 2 Let x_0, x_1, x_2, \dots be the sequence generated by the Newton-Raphson method applied

to the function $f(x) = x^3 - 2x + 2$ with $x_0 = 1$. Then the sequence

- (A) converges to 0.
 (B) becomes unbounded.
 (C) converges to a root of $f(x)$.
 (D) does not converge.

Q.No. 3 Let $z(t)$ be the solution of the initial value problem

$$\frac{d^2z}{dt^2} = bz, z(0) = 0, \frac{dz}{dt}(0) = 1 \quad \text{for } t \geq 0.$$

If the planar curve parameterized by t having x -coordinate $z(t)$ and

y -coordinate $\frac{dz}{dt}$ is closed, then necessarily

- (A) $b > 0$.
 (B) $b < 0$.
 (C) $b = 0$.
 (D) b is a non-zero rational number.

Q.No. 4

Let z be a complex number. Then the series $\sum_{n=0}^{\infty} \frac{z^{2n}}{(2n)!}$

- (A) converges for all z .
 (B) converges for $|z| \leq 1$ and diverges for $|z| > 1$.
 (C) converges for $z = 0$ and diverges for any $z \neq 0$.
 (D) converges for $|z| < 1$ and diverges for $|z| \geq 1$.

Q.No. 5 Let $\vec{V}(x, y, z) = ax\vec{i} - bz\vec{j} + cy\vec{k}$ be a vector field whose curl is zero. Then necessarily

- (A) $a = b = c$.
 (B) $a = -b = c$.
 (C) $b = c$.
 (D) $b = -c$.

Q.No. 6 Let $f(x)$ be a continuous function on the real line such that for any x ,

$$\int_0^{x^2} f(t) dt = x^2(1 + x^2). \text{ Then } f(2) \text{ is } \underline{\hspace{2cm}}.$$

Q.No. 7

The number of points at which the function $f(x, y) = \frac{x^2}{2} + \frac{y^4}{4} - \frac{y^2}{2}$ has local minima is $\underline{\hspace{2cm}}$.

Q8 - Q11 carry two marks each.

Q.No. 8 Let $f(t)$ be a real-valued differentiable function on $(-1, 1)$ such that $f(0) = 0$ and

$$\left| \frac{df}{dt} \right| < 1 \quad \text{for } 0 < t < 1.$$

Then the series $\sum_{n=0}^{\infty} f(0.5)^n$

- (A) converges but not absolutely.
 (B) is unbounded.
 (C) converges absolutely.
 (D) is bounded but does not converge.

Q.No. 9 Let X be a random variable with probability density function

$$f(t) = \begin{cases} \exp(-t) & \text{for } t \geq 0, \\ 0 & \text{for } t < 0. \end{cases}$$

Let $0 < a < b$. Then the probability $\mathbf{P}(X \leq b | X \geq a)$ depends only on

- (A) $b - a$.
 (B) b .
 (C) a .
 (D) $a + b$.

Q.No. 10

Let A be a 3×3 matrix such that $A^2 = A$. Then it is necessary that

- (A) A is the identity matrix or the zero matrix.
- (B) the determinant of A^4 is either 0 or 1.
- (C) the rank of A is 3.
- (D) A has one imaginary eigenvalue.

Q.No. 11 Players A and B take turns to throw a fair dice with six faces. If A is the first player to throw, then the probability of B being the first one to get a six is ____ (round off to two decimal places).

XE: Engineering Sciences - B: Fluid Mechanics

Q1 - Q9 carry one mark each.

Q.No. 1 Figures given below show the velocity and shear stress profiles for the flow in a duct. In each option, '1' represents velocity profile and '2' represents shear stress profile.

Choose the correct option that closely represents the turbulent flow condition.

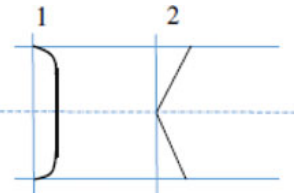
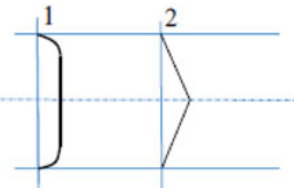
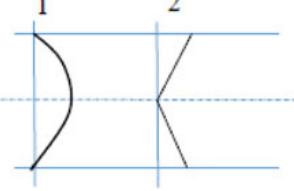
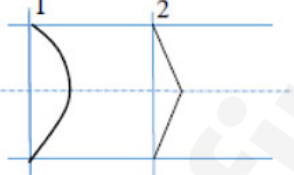
- (A) 
- (B) 
- (C) 
- (D) 

Q.No. 2



The variation of shear stress (τ) against strain rate (du/dy) is given in the Figure.

Identify the line/curve among P, Q, R and S, that represents an ideal fluid.

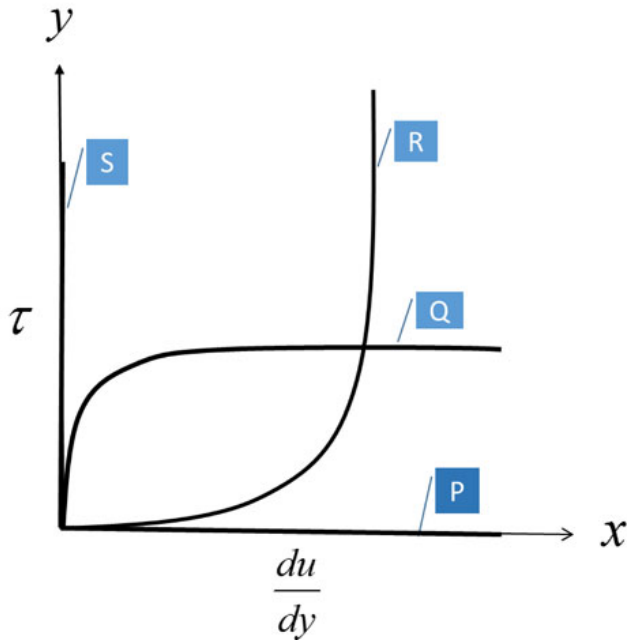

- (A) S
- (B) P
- (C) Q
- (D) R

Q.No. 3 A body is under stable equilibrium in a homogeneous fluid, where CG and CB are center of gravity and center of buoyancy, respectively.

Two statements 'P' and 'Q' are given below:

P: For a fully submerged condition, CG should always be below CB

Q: For a floating body, CG need not be below CB

Choose the option that is valid for the present situation.

- (A) P is False; Q is True when metacentre is below CG
- (B) P is False; Q is True when metacentre is above CG
- (C) P is True; Q is True when metacentre is below CG
- (D) P is True; Q is True when metacentre is above CG

Q.No. 4 A laminar hydrodynamic boundary layer over a smooth flat plate is shown in the Figure. The shear stress at the wall is denoted by τ_w . Which one of the following conditions is correct.

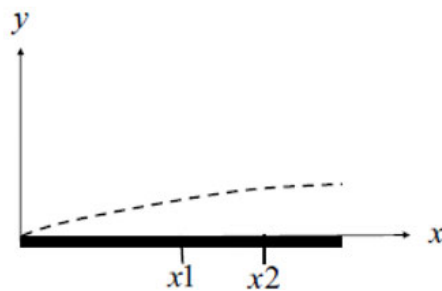

- (A) Pressure is varying along 'x' and $(\tau_w)_{x1} > (\tau_w)_{x2}$
- (B) Pressure is constant along 'x' and $(\tau_w)_{x2} > (\tau_w)_{x1}$
- (C) Pressure is constant along 'x' and $(\tau_w)_{x1} > (\tau_w)_{x2}$
- (D) Pressure is varying along 'x' and $(\tau_w)_{x2} > (\tau_w)_{x1}$

Q.No. 5

A non-dimensional number known as **Weber** number is used to characterize

which one of the following flows,

- (A) Motion of fluid in open channel
- (B) Motion of fluid droplets
- (C) Motion of fluid at high velocity
- (D) Motion of fluid through a pipe

- Q.No. 6** A uniform approach flow is subjected to an unsteady and periodic flapping plate as shown in the Figure. Tracer is released to obtain flow visualization lines, which are marked as 'P', 'Q' and 'R'.

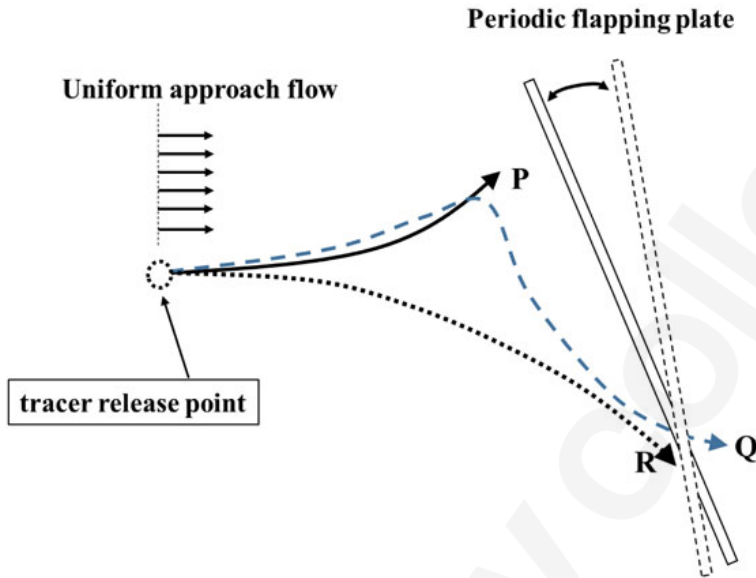

Choose the correct option that the line 'R' represents

- (A) Streakline
- (B) Streamline
- (C) Pathline
- (D) Timeline

- Q.No. 7** The volume flow between any two points not lying on the same streamline in a flow field is equal to
- (A) Change in strain rate between the points
 - (B) Change in vorticity between the points
 - (C) Change in potential function between the points
 - (D) Change in stream function between the points

- Q.No. 8** A liquid flow through a horizontal smooth pipe of diameter 5 cm and discharges into a collection tank of dimension 50 cm x 50 cm x 50 cm. Time taken for a 10 cm rise of liquid level in the collection tank is 40 s.

The flow velocity in the pipe is ----- m/s (rounded off to two decimal places).

- Q.No. 9** The potential function for a two dimensional incompressible flow field is given

$$\text{as: } \phi = \frac{x^3}{3} - xy^2.$$

Magnitude of the velocity vector at point (2,1) is _____ m/s

Q10 - Q22 carry two marks each.

- Q.No. 10**

Column I represents a list of elementary plane flows and Column II represents flow past geometry obtained by superposition of these elementary plane flows.

Column I	Column II
P: Source, Sink, Uniform flow	1: Rankine half body
Q: Doublet, Uniform flow	2: Rotating Cylinder
R: Source, Uniform flow	3: Rankine oval
S: Doublet, Free vortex, Uniform flow	4: Cylinder

The correct match between Columns I and II is,

- (A) P-3; Q-2; R-1; S-4
 (B) P-1; Q-2; R-3; S-4
 (C) P-3; Q-4; R-1; S-2
 (D) P-1; Q-4; R-3; S-2

Q.No. 11 The velocity field for a flow is $\vec{V} = 5t\hat{i} + 2xz\hat{j} + 2ty\hat{k}$, where t is time. Choose the

correct option representing the total acceleration at (x, y, z, t)

- (A) $5\hat{i} + 2(x+z)\hat{j} + 2(t+y)\hat{k}$
 (B) $5\hat{i} + t(10z+4xy)\hat{j} + (2y+4xzt)\hat{k}$
 (C) $5\hat{i} + 2y\hat{k}$
 (D) $2t(2xy+5z)\hat{j} + 4xzt\hat{k}$

Q.No. 12 An incompressible viscous fluid is placed between two infinite horizontal parallel plates as shown in Figure. The plates move in opposite direction with constant velocities U_1 and U_2 . The pressure gradient in the x -direction is zero and the only body force is due to the fluid weight. The flow is steady, laminar and two-dimensional. Assume velocity component in 'y' direction to be zero.

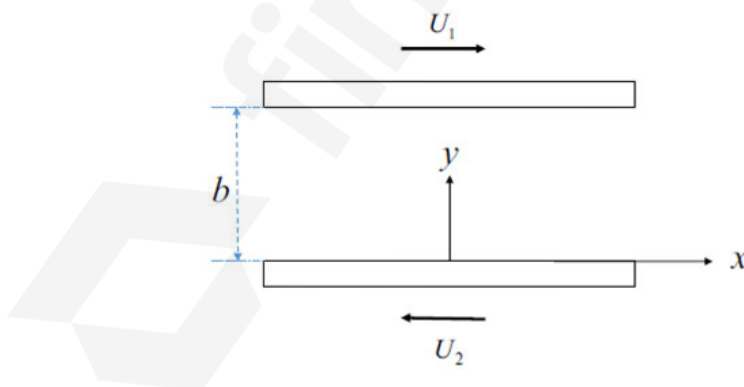

The correct expression for the velocity distribution between the plates is:

- (A) $\left(\frac{U_1+U_2}{b}\right)y - U_2$
 (B) $\left(\frac{U_1-U_2}{b}\right)y - U_1$
 (C) $\left(\frac{U_1+U_2}{b}\right)y + U_2$
 (D)

$$\left(\frac{U_1 + U_2}{b}\right)y + U_1$$

Q.No. 13 The stream function of a flow field is $\Psi = k(x^2 - y^2x)$ where k is a constant.

Which one of the following represents the vorticity?

- (A) $-2k$
- (B) $2k(x+1)$
- (C) $2k(x-1)$
- (D) $-2k(x+1)$

Q.No. 14 Consider a two dimensional, incompressible steady flow of a Newtonian fluid in

which the velocity field is $u = -2xy$, $v = y^2 - x^2$. Pressure gradients in the x - and y - directions are

- (A) $\frac{\partial p}{\partial x} = -2\rho(xy^2 + x^3)$, $\frac{\partial p}{\partial y} = -2\rho(x^2y + y^3)$
- (B) $\frac{\partial p}{\partial x} = -2\rho(xy^2 - x^3)$, $\frac{\partial p}{\partial y} = -2\rho(x^2y + y^3)$
- (C) $\frac{\partial p}{\partial x} = -2\rho(xy^2 + x^3)$, $\frac{\partial p}{\partial y} = -2\rho(x^2y - y^3)$
- (D) $\frac{\partial p}{\partial x} = -2\rho(xy^2 - x^3)$, $\frac{\partial p}{\partial y} = -2\rho(x^2y - y^3)$

Q.No. 15 A hydroelectric power plant takes in $30 \text{ m}^3/\text{s}$ of water through its turbine and discharges it to the atmosphere with $V_2 = 2 \text{ m/s}$. The total head loss in the turbine and penstock system is 20 m . (Assume turbulent flow with kinetic energy correction factor as 1.1 . Density of water is 1000 kg/m^3 and acceleration due to gravity, g is 10 m/s^2).

The net head available to the turbine for power generation is ----- m.

(rounded off to one decimal place).

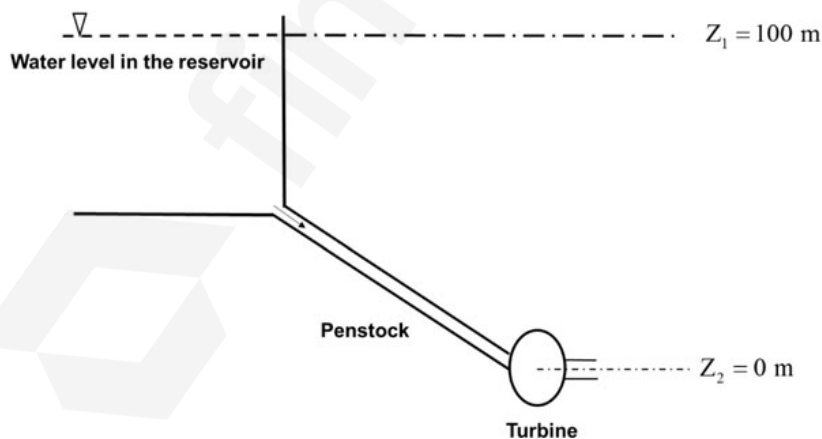

Q.No. 16

Water flows at an average velocity, v of 10 m/s through a horizontal smooth tube of diameter, d 5 cm. The friction factor, f is 0.02. Head loss is obtained using

Darcy-Weisbach relation $\frac{flv^2}{2gd}$. The fluid pressure, p measured at various stations are reported in the table below. The length of the pipe, l between station 0 and station 6 is 6 m.

Station	0	1	2	3	4	5	6
p , kPa	304	273	255	240	226	213	-

If acceleration due to gravity, $g = 10 \text{ m/s}^2$ and density of water = 1000 kg/m^3 ,

then the fluid pressure at station 6 is _____ kPa
(rounded off to one decimal place)

- Q.No. 17 A sphere model of 10 cm diameter is tested in water flowing at 2 m/s. The drag force is measured as 5 N. Prototype of 1.5 m in diameter is tested in air with dynamic similarity conditions. (Density of water is 1000 kg/m^3 , density of air is 1.2 kg/m^3 , viscosity of water is 0.001 Ns/m^2 and viscosity of air is $1.78 \times 10^{-5} \text{ Ns/m}^2$).

Drag force experienced by the prototype is _____ N (rounded off to two decimal places).

- Q.No. 18 A liquid of viscosity $1.74 \times 10^{-3} \text{ Ns/m}^2$ is flowing through a horizontal capillary tube of diameter 0.5 mm. The flow in the tube is steady, incompressible, and fully developed laminar flow. The pressure drop across two locations spaced 1 m apart in the tube is 1.0 MPa.

The flow rate in the tube _____ mm^3/s .

- Q.No. 19 A venturimeter with 75 mm diameter throat is placed in a 150 mm diameter pipeline carrying water at 25°C . The pressure drop between the upstream tap and the venturi throat is 40 kPa. (Density of water = 1000 kg/m^3).

The flow rate is _____ m^3/s (rounded off to three decimal places).

- Q.No. 20

A water jet with velocity \vec{V}_{jet} impinges normal to a moving flat plate with velocity \vec{V}_{plate} such that the jet splits equally into two halves as shown in Figure. The jet cross-sectional area is 2 cm^2 , \vec{V}_{jet} is 20 m/s and \vec{V}_{plate} is 10 m/s and density of water is 1000 kg/m^3 . Consider steady flow and neglect weight of the jet, weight of the plate and frictional losses.

The absolute value of the force required to keep the plate moving at constant velocity \vec{V}_{plate} is _____ N.

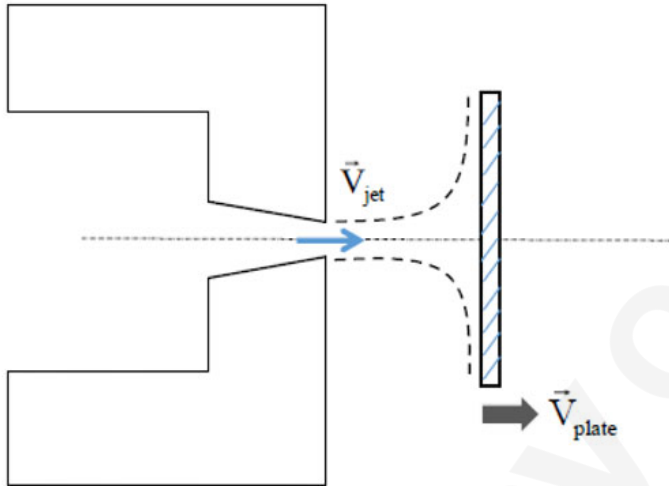

Q.No. 21 In an inverted manometer (as shown in the Figure), the pressure difference, $P_B - P_A$ is 100 kPa .

Use specific gravity of oil as 0.8 , density of water as 1000 kg/m^3 , density of mercury as 13600 kg/m^3 and acceleration due to gravity as 10 m/s^2 .

The height of the water column, H is _____ cm. (rounded off to one decimal place).

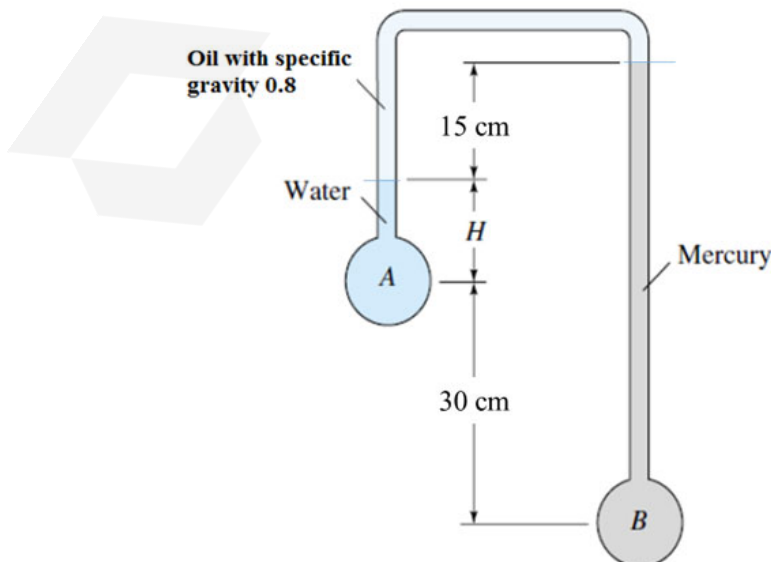

- Q.No. 22 An incompressible, steady flow with uniform velocity condition at the inlet between parallel plates is shown in Figure. The flow develops into a parabolic laminar profile with $u=ay(y_0-y)$ at the downstream end, where 'a' is a constant. Assume unit depth of the plate. For $U_0=7.5$ cm/s, $y_0=3$ cm and the fluid with density, $\rho=800$ kg/m³

The value of 'a' is _____.



XE: Engineering Sciences - C: Materials Science

Q1 - Q9 carry one mark each.

- Q.No. 1 A Pb-Sn sample of eutectic composition, containing α - and β - phases, is examined in a scanning electron microscope. The α -phase contains ~97 wt% Pb (atomic number 82) while β -phase contains ~99 wt% Sn (atomic number 50). The ratio of number of backscattered electrons escaping from α -phase to that from β -phase would be:
- (A) Less than 1
 (B) Equal to 1
 (C) Greater than 1
 (D) Equal to 0
- Q.No. 2 Smallest or minimum feature size that can be theoretically resolved in an optical microscope does NOT depend on:
- (A) Refractive index of the medium between the lens and the focal point
 (B) Intensity of radiation
 (C) Wavelength of radiation
 (D) Numerical aperture of the objective lens
- Q.No. 3 Following diagram shows a square 2-D lattice with a hexagonal motif (dark colored). The rotational symmetry element that must be present in the system is:

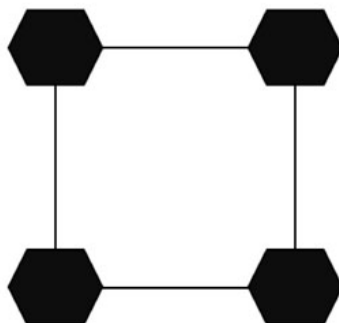

- (A) Six-fold rotation
 (B) Two-fold rotation

- (C) Three-fold rotation
(D) Four-fold rotation

Q.No. 4 Density of states, $D(E)$, in a three dimensional solid varies with energy (E) as

- (A) $E^{1/2}$
(B) E^0
(C) $E^{-1/2}$
(D) $E^{3/2}$

Q.No. 5 The variation of molar volume (V_m) of a liquid showing glass transition temperature (T_g) while cooling from its melting temperature (T_m) is depicted by:

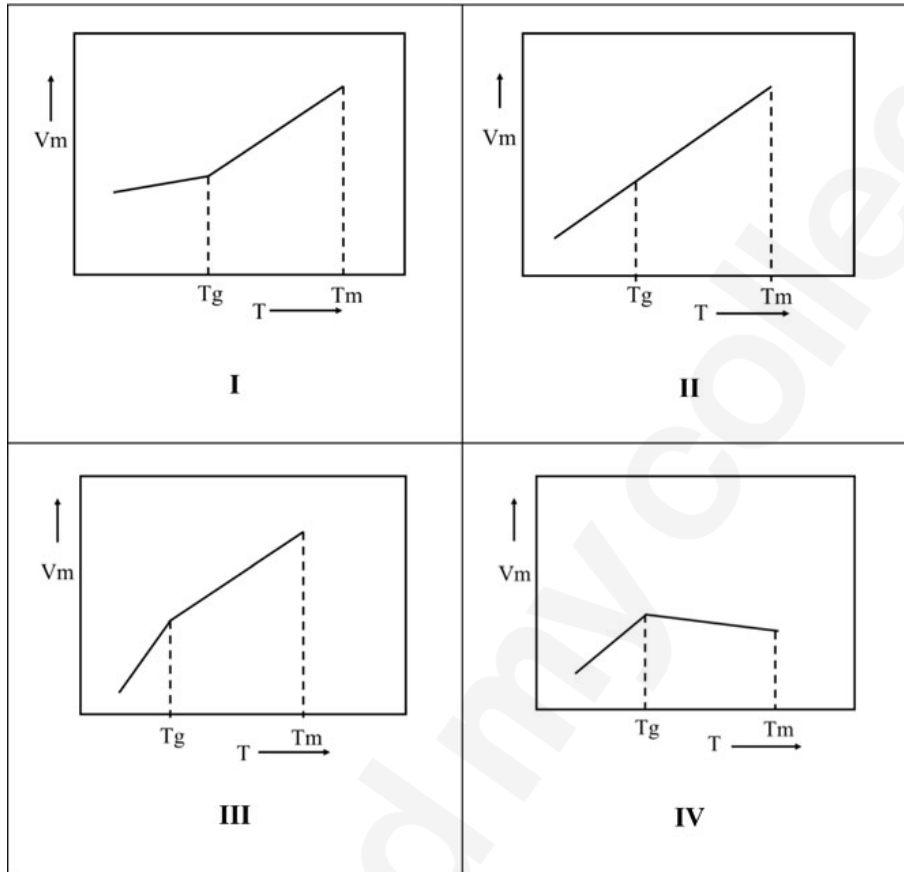

- (A) I
(B) II
(C) III
(D) IV

Q.No. 6

Find the correct match between polymer name in Column I and the monomer type in Column II.

Column I	Column II
(I) Polyethylene	(P) $\begin{array}{c} \text{H} \quad \text{H} \\ \quad \\ \text{C} = \text{C} \\ \quad \\ \text{H} \quad \text{CH}_3 \end{array}$
(II) Polypropylene	(Q) $\begin{array}{c} \text{H} \quad \text{H} \\ \quad \\ \text{C} = \text{C} \\ \quad \\ \text{H} \quad \text{Cl} \end{array}$
(III) Polyvinyl chloride	(R) $\begin{array}{c} \text{H} \quad \text{H} \\ \quad \\ \text{C} = \text{C} \\ \quad \\ \text{H} \quad \text{C}_6\text{H}_5 \end{array}$
(IV) Polystyrene	(S) $\begin{array}{c} \text{H} \quad \text{H} \\ \quad \\ \text{C} = \text{C} \\ \quad \\ \text{H} \quad \text{H} \end{array}$

- (A) I-P, II-S, III-R, IV-Q
 (B) I-R, II-Q, III-S, IV-P
 (C) I-S, II-P, III-Q, IV-R
 (D) I-S, II-R, III-Q, IV-P

Q.No. 7 A ceramic has a fracture toughness (K_{Ic}) of $1 \text{ MPa}\cdot\text{m}^{1/2}$. If this ceramic is to be exposed to a maximum stress (σ) of 200 MPa, the maximum value of half crack length 'a' (in micrometer, μm), below which the material does not fail, is _____ μm (round off to one decimal place). Loading condition for the sample is shown in the schematic. Assume geometrical factor $f = 1.2$.

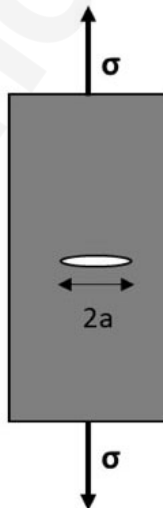

Q.No. 8

A ceramic material is periodically heated and cooled between 25°C and a higher temperature, T_f . During thermal cycling, the material remains dimensionally constrained. The material can withstand a maximum compressive stress of 200 MPa without failure. Material's coefficient of thermal expansion is $7.5 \times 10^{-6} \text{ }^{\circ}\text{C}^{-1}$ and modulus of elasticity (E) is 200 GPa. The lowest value of T_f (in $^{\circ}\text{C}$) at which material will fail is _____ $^{\circ}\text{C}$ (round-off to the nearest integer). Assume that there is no plastic deformation during thermal cycling.

- Q.No. 9 During homogeneous solidification of a liquid metal, the radius of critical nucleus (in nanometer, nm) at a temperature T_S which is below the melting point (T_m), is _____ nm (round-off to one decimal place). Given that γ_{sl} (solid liquid interfacial energy) is 0.18 J.m^{-2} and ΔG_v (change in volume free energy upon transformation from liquid to solid) at T_S is $0.18 \times 10^9 \text{ J.m}^{-3}$.

Q10 - Q22 carry two marks each.

- Q.No. 10 Read the two statements related to sintering and select the correct option.

Statement-1: Sintering in vacuum leads to improved densification as compared to sintering under ambient (at atmospheric pressure) condition.

Statement-2: Closed pores formed during sintering inhibit full densification.

- (A) Both Statement-1 and Statement-2 are FALSE
 (B) Both Statement-1 and Statement-2 are TRUE
 (C) Statement-1 is TRUE but Statement-2 is FALSE
 (D) Statement-1 is FALSE but Statement-2 is TRUE

- Q.No. 11 Select the correct option that appropriately matches the process to the material/product that can be fabricated using them.

<u>Process</u>	<u>Material/Product</u>
(I) Powder processing	(P) Organic semiconductor thin films
(II) Spin coating	(Q) Single crystal silicon
(III) Czochralski process	(R) Poly-silicon
(IV) Chemical vapor deposition	(S) Porous bronze bearings

- (A) I-S, II-P, III-R, IV-Q
 (B) I-S, II-R, III-Q, IV-P
 (C) I-S, II-P, III-Q, IV-R
 (D) I-P, II-R, III-Q, IV-S

- Q.No. 12 Consider a FCC structured metal with lattice parameter $a = 3.5 \text{ \AA}$. If the material is irradiated using X-rays of wavelength $\lambda = 1.54056 \text{ \AA}$, the Bragg angle (2θ) corresponding to the fourth reflection will be:

- (A) 88.21°
 (B) 76.99°
 (C) 99.35°
 (D) 93.80°

- Q.No. 13

The number of Schottky defects per mole of KCl at 300 °C under equilibrium condition will be:

Given:

Activation energy for the formation of Schottky defect = 250 kJ.mol⁻¹

Avogadro number = 6.023 × 10²³ mol⁻¹

Universal Gas Constant = 8.314 J.K⁻¹.mol⁻¹

- (A) 1.21 × 10¹⁸
 (B) 1.52 × 10¹⁶
 (C) 9.75
 (D) 2.42 × 10¹²

- Q.No. 14 In an industry, the probability of an accident occurring in a given month is $\frac{1}{100}$. Let $P(n)$ denote the probability that there will be no accident over a period of 'n' months. Assume that the events of individual months are independent of each other. The smallest integer value of 'n' such that $P(n) \leq \frac{1}{2}$ is _____ (round off to the nearest integer).
- Q.No. 15 For a FCC metal, the ratio of surface energy of {111} surface to {100} surface is _____ (round-off to two decimal places). Assume that only the nearest neighbor broken bonds contribute to the surface energy.
- Q.No. 16 Pure silicon (Si) has a band gap (E_g) of 1.1 eV. This Si is doped with 1 ppm (parts per million) of phosphorus atoms. Si contains 5×10^{28} atoms per m³ in pure form. At temperature $T = 300$ K, the shift in Fermi energy upon doping with respect to intrinsic Fermi level of pure Si will be _____ eV (with appropriate sign and round-off to two decimal places).
 Intrinsic carrier concentration of Si, n_i , is given as:

$$n_i = 2 \left(\frac{2\pi m k_B T}{h^2} \right)^{3/2} \exp \left(-\frac{E_g}{2k_B T} \right)$$

Given:

Mass of an electron, $m = 9.1 \times 10^{-31}$ kg

Charge of an electron, $e = 1.6 \times 10^{-19}$ C

Boltzmann constant, $k_B = 1.38 \times 10^{-23}$ J.K⁻¹

Planck's constant, $h = 6.6 \times 10^{-34}$ J.s⁻¹

Q.No. 17

The schematic diagram shows the light of intensity I_0 incident on a material (shaded grey) of thickness, x , which has an absorption coefficient, α and reflectance, R . The intensity of transmitted light is I . The reflection of light (of a particular wavelength) occurs at both the surfaces (surfaces indicated in the diagram). The transmittance is estimated to be _____ (round-off to three decimal places).

Given that for the wavelength used, $\alpha = 10^3 \text{ m}^{-1}$ and $R = 0.05$.

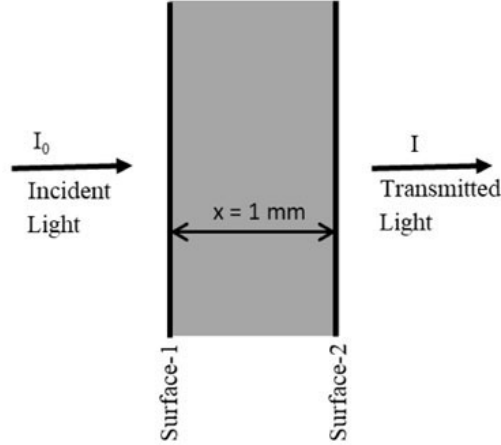

Q.No. 18 Fe_3O_4 (also represented as $\text{FeO} \cdot \text{Fe}_2\text{O}_3$) is a FCC structured inverse spinel (AB_2O_4) material where $1/8$ of tetrahedral sites are occupied by half of B cations and $1/2$ of the octahedral sites are occupied by remaining B and A cations. The magnetic moments of cations on octahedral sites are antiparallel with respect to those on tetrahedral sites. Atomic number of Fe is 26 and that of O is 8. The saturation magnetic moment of Fe_3O_4 per formula unit in terms of Bohr magnetons (μ_B) will be _____ μ_B . Ignore contribution from orbital magnetic moments.

Q.No. 19 A piezoelectric ceramic with piezoelectric coefficient (d_{zz}) value of $100 \times 10^{-12} \text{ C} \cdot \text{N}^{-1}$ is subjected to a force, F_z , of 10 N, applied normal to its x-y face, as shown in the figure. If relative dielectric constant (ϵ_r) of the material is 1100, the voltage developed along the z-direction of the sample will be _____ Volts (round-off to two decimal places). Ignore any nonlinear effects.

Given: Permittivity of free space (ϵ_0) is $8.85 \times 10^{-12} \text{ F} \cdot \text{m}^{-1}$.

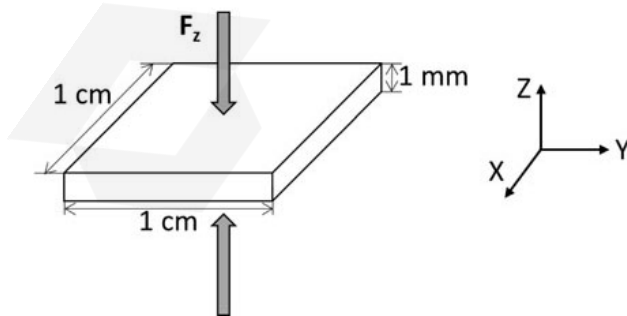

Q.No. 20

Silicon carbide (SiC) particles are added to Aluminum (Al) matrix to fabricate particle reinforced Al-SiC composite. The resulting composite is required to possess specific modulus (E/ρ ; E: elastic modulus, ρ : density) three times that of pure Al. Assuming iso-strain condition, the volume fraction of SiC particles in the composite will be _____ (round-off to two decimal places).

Material	E (GPa)	ρ (g.cm ⁻³)
Al	69	2.70
SiC	379	2.36

Q.No. 21 Isothermal weight gain per unit area ($\Delta W/A$, where ΔW is the weight gain (in mg) and A is the area (in cm²)) during oxidation of a metal at 600 °C follows parabolic rate law, where, $\Delta W/A = 1.0$ mg.cm⁻² after 100 min of oxidation. The $\Delta W/A$ after 500 min at 600 °C will be _____ mg.cm⁻² (round-off to two decimal places).

Q.No. 22 A plain carbon steel sample containing 0.1 wt% carbon is undergoing carburization at 1100 °C in a carbon rich surroundings with fixed carbon content of 1.0 wt% all the time. The carburization time necessary to achieve a carbon concentration of 0.46 wt% at a depth of 5 mm at 1100 °C is _____ hour (round off to the nearest integer).

Given: Diffusivity of carbon in iron at 1100 °C is 6.0×10^{-11} m².s⁻¹ and

erf(z)	z
0.56	0.55
0.60	0.60
0.64	0.65
0.68	0.70

XE: Engineering Sciences - D: Solid Mechanics

Q1 - Q9 carry one mark each.

Q.No. 1 Which among the following statements is true for a body moving on a dry surface under the action of applied forces?

(A) Kinetic-friction force is zero.
 (B) Kinetic-friction force is equal to the static-friction force.
 (C) Kinetic-friction force is greater than the static-friction force.
 (D) Kinetic-friction force is lower than the static-friction force.

Q.No. 2 Consider an isotropic material with Young's modulus E and Poisson's ratio ν . The bulk modulus of this material is given by _____.

- (A) $\frac{E}{(1 - \nu^2)}$
 (B) $\frac{E}{2(1 + \nu)}$
 (C) $\frac{E}{3(1 - 2\nu)}$

(D)
$$\frac{Ev}{(1 + \nu)(1 - 2\nu)}$$

- Q.No. 3 A body subjected to _____ does not undergo change in volume.
- (A) uniform tension
 (B) pure shear
 (C) pure bending
 (D) hydrostatic pressure

- Q.No. 4 The angular momentum of a particle moving under a central force is
- (A) zero.
 (B) constant in both magnitude and direction.
 (C) constant in magnitude but not direction.
 (D) constant in direction but not magnitude.

- Q.No. 5 According to Euler-Bernoulli beam theory, which one of the following statements best describes the state of a beam subjected to pure bending?
- (A) Transverse shear stress and transverse shear strain are zero.
 (B) Transverse shear stress is not zero but transverse shear strain is zero.
 (C) Transverse shear stress is zero but transverse shear strain is not zero.
 (D) Transverse shear stress and transverse shear strain are not zero.

- Q.No. 6 A rigid square ABCD is subjected to planar forces at the corners as shown.

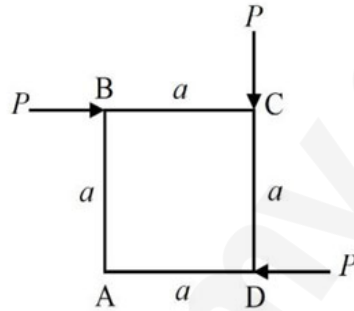

For this planar force system, the equivalent force couple system at corner A can be represented as

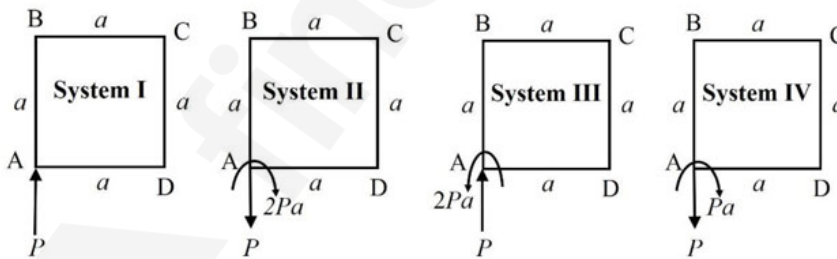

- (A) System I
 (B) System II
 (C) System III
 (D) System IV

- Q.No. 7 A particle of mass 0.1 kg, which is released from rest, falls vertically downward under gravity in a fluid. The fluid offers a resistive force, which is linearly proportional to the particle velocity with 0.1 N.s/m as the constant of proportionality. The uniform gravitational acceleration is 10 m/s^2 throughout the trajectory of the particle. The magnitude of the particle velocity (in m/s) at time 1 s after release (rounded off to two decimal places) is _____.

- Q.No. 8

The state of two-dimensional plane stress at a point in a body is shown on the triangular element ABC, where $\cos \theta = \frac{3}{5}$ and $\sin \theta = \frac{4}{5}$. The normal stress (in MPa) on the plane AC is _____.

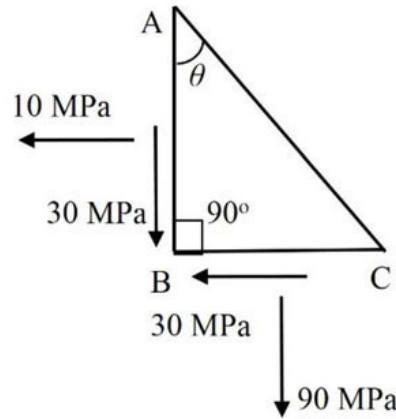

Q.No. 9 Consider two point masses $m = 10 \text{ kg}$ and $M = 30 \text{ kg}$ connected by a massless inextensible string passing over a massless and frictionless pulley with radius $a = 100 \text{ mm}$ as shown. The masses are released from rest and move vertically under the action of gravity. Let acceleration due to gravity, $g = 10 \text{ m/s}^2$. The tension (in N) in the string is _____.

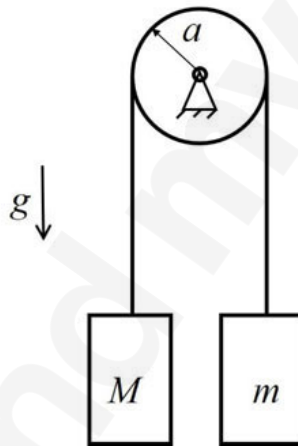

Q10 - Q22 carry two marks each.

Q.No. 10 The cantilever beam AC is composed of two segments AB and BC that are rigidly connected at B. The flexural rigidity of the segment AB is EI , whereas, the flexural rigidity of the segment BC is assumed to be infinite. Determine the magnitude of slope at B due to a force P applied at C.

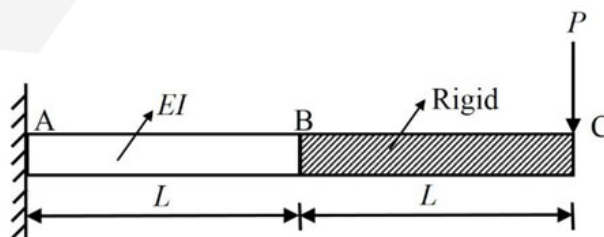

- (A) $\frac{5PL^2}{6EI}$
- (B) $\frac{PL^2}{2EI}$
- (C) $\frac{PL^2}{2EI}$

(D) $\frac{PL^2}{EI}$
 $\frac{3PL^2}{2EI}$

Q.No. 11 Determine the correctness or otherwise of the following Assertion [a] and Reason [r].

Assertion [a]: Efficient columns are designed so that most of the column's cross-sectional area is located as far away as possible from the principal centroidal axes of the section.

Reason [r]: Load carrying capacity of columns will increase as the moment of inertia of the cross-section increases.

- (A) Both [a] and [r] are true and [r] is the correct reason for [a].
 (B) Both [a] and [r] are true but [r] is not the correct reason for [a].
 (C) Both [a] and [r] are false.
 (D) [a] is true but [r] is false.

Q.No. 12 Consider the structure consisting of two massless elastic bars AB and BC, each of length L , cross-sectional area A , and Young's modulus E . Connections at A, B, C are all pinned. A horizontal force P acts on the joint B as shown. Calculate the horizontal deflection of the joint B.

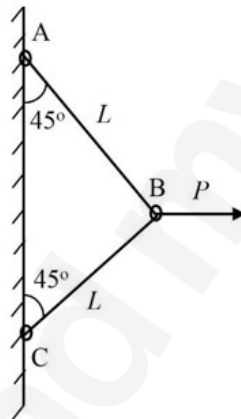

- (A) $\frac{PL}{2AE}$
 (B) $\frac{PL}{AE}$
 (C) $\frac{\sqrt{2}PL}{AE}$
 (D) $\frac{AE}{PL\sqrt{2AE}}$

Q.No. 13

A rigid bar ABC of mass m and length L is hinged at A and has a point mass M attached at C. An elastic spring with linear stiffness k is attached at B as shown. Ignore the effect of gravity and damping. The natural frequency of small oscillations of this system is _____.

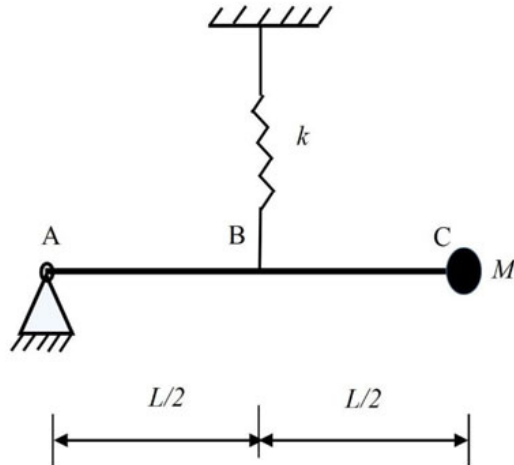

- (A) $\sqrt{\frac{k}{4M + m}}$
- (B) $\sqrt{\frac{k}{2(M + 2m)}}$
- (C) $\sqrt{\frac{3k}{3M + m}}$
- (D) $\sqrt{\frac{3k}{4(3M + m)}}$

Q.No. 14 A beam of flexural rigidity EI is fixed at A and supported by a linear spring of stiffness $k = EI/L^3$ at B. Determine the compressive force developed in the spring, when the beam is subjected to a uniformly distributed load of w per unit length.

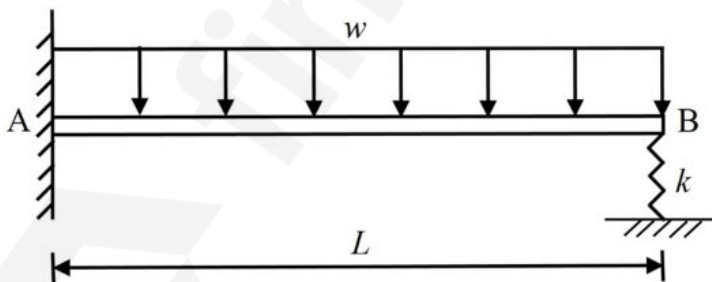

- (A) $\frac{3wL}{32}$
- (B) $\frac{3wL}{16}$
- (C) $\frac{wL}{2}$
- (D) $\frac{wL}{8}$

Q.No. 15

The bar AB is fixed at A and is separated by a gap of 0.005 mm from wall at C as shown. The temperature of the bar is increased by 10°C . If the Young's modulus of the bar is $E = 200 \text{ GPa}$ and the coefficient of thermal expansion is $\alpha = 10 \times 10^{-6} / ^{\circ}\text{C}$, then the magnitude of the compressive stress (in MPa) developed in the bar is _____.

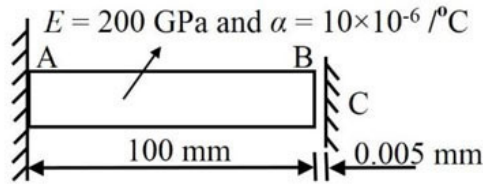

- Q.No. 16 A thin walled spherical pressure vessel has mean radius 1000 mm and wall thickness 10 mm. The material has Young's modulus 200 GPa and Poisson's ratio 0.25. If the internal pressure is 100 MPa, the radial displacement (in mm) of the spherical pressure vessel (rounded off to two decimal places) is _____.
- Q.No. 17 A particle of mass $m = 100 \text{ kg}$ is released from rest and falls under gravity through a height of $H = 1 \text{ m}$ directly onto an upright massless elastic bar of length $L = 200 \text{ mm}$, Young's modulus 200 GPa, and cross-sectional area 100 mm^2 . Assume the following during impact: (a) particle mass sticks to the bar, (b) the bar does not buckle, and (c) no energy is lost. Use gravitational acceleration $g = 10 \text{ m/s}^2$. The maximum axial compression (in mm) of the bar due to the impact (rounded off to three decimal places) is _____.

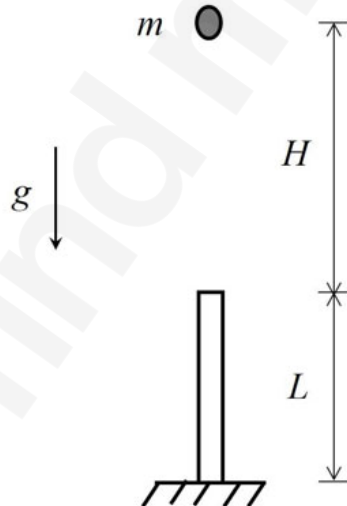

Q.No. 18

A pin-jointed truss has a pin support at A and a roller support at C. All the members are made of same material and have the same cross-section. Neglect the self-weight of the members. Due to the applied loading shown, the total number of zero force members is _____.

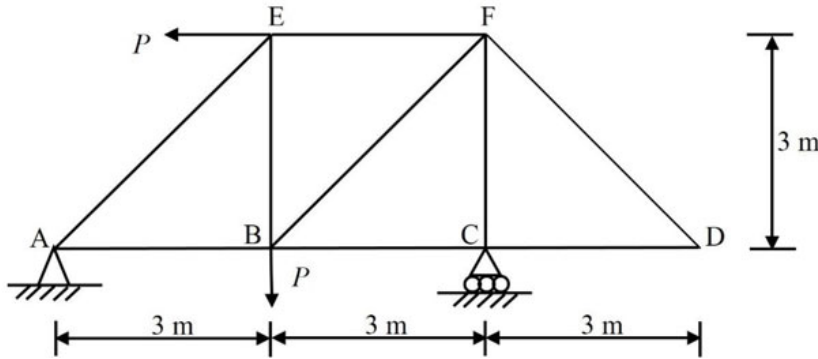

Q.No. 19 Two beams AB and BC having diameter of 100 mm are connected by an internal hinge at B. The structure is fixed at A and roller supported at C. Load of $P = 1 \text{ kN}$ is applied at B. Ignoring the effect of any transverse shear stress, the tensile stress (in MPa) developed at A due to bending (rounded off to three decimal places) is _____.

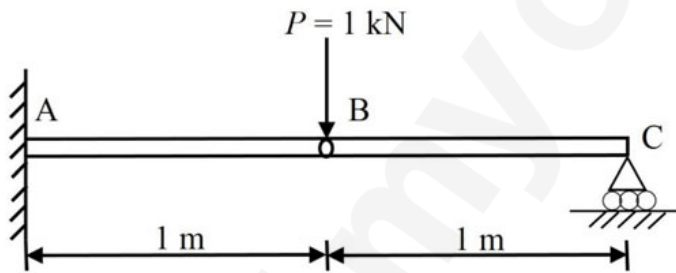

Q.No. 20 The shear force diagram for a beam AD, which is simply supported at A and D, is shown. The magnitude of the maximum bending moment (in kN.m) is _____ (rounded off to three decimal places).

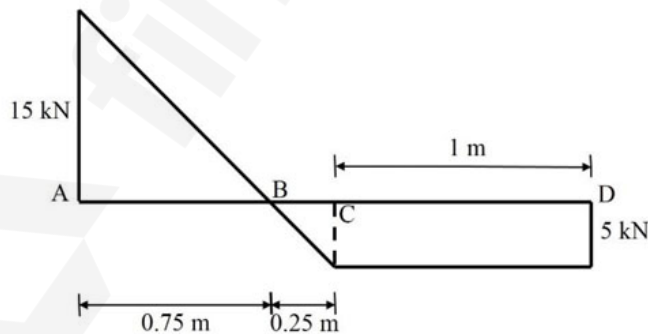

Q.No. 21

A rectangular thin plate with Young's modulus 200 GPa and Poisson's ratio 0.30 is subjected to uniform stress distribution at its edges as shown. However, it is stated that the dimension b of the plate does not change under the action of the stress components σ_{xx} and σ_{yy} . Considering micro-strains (in 10^{-6}), the change in the length of dimension a (in mm) is _____ (rounded off to three decimal places).

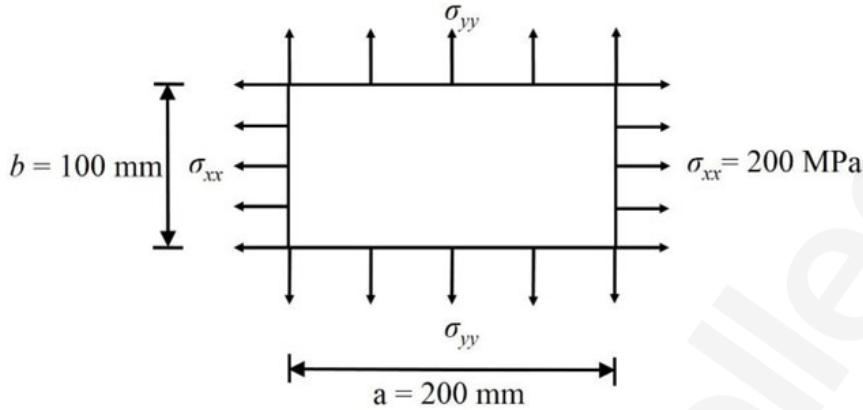

- Q.No. 22 A solid transmission shaft has length 10 m and diameter 100 mm. The shaft is supported by frictionless bearings at ends that act as simple supports. In addition to its self-weight acting as a uniformly distributed load per unit length, an operational torque of $5\pi \text{ kN.m}$ is applied. The density and yield strength of the material are 8000 kg/m^3 and 350 MPa , respectively. Use gravitational acceleration as 10 m/s^2 and ignore the effect of transverse shear stress. The factor of safety of the shaft as per maximum shear stress failure theory (Tresca criterion) is _____ (rounded off to two decimal places).

XE: Engineering Sciences - E: Thermodynamics

Q1 - Q9 carry one mark each.

- Q.No. 1 If x and y are two independent intensive properties of a thermodynamic system, then which relation among the followings fails to identify z as another thermodynamic property?
- (A) $dz = x dy + y dx$
 (B) $dz = x dy - y dx$
 (C) $dz = 2 dy + dx$
 (D) $dz = \frac{dy}{x} - \frac{y dx}{x^2}$
- Q.No. 2 Internal energy of a thermodynamic system is defined by the
- (A) zeroth law of thermodynamics
 (B) first law of thermodynamics
 (C) second law of thermodynamics
 (D) third law of thermodynamics
- Q.No. 3 In a polytropic process described by $PV^n = \text{constant}$, if $n = 0$, the process is called as
- (A) isobaric
 (B) isochoric
 (C) isothermal
 (D) isentropic

Q.No. 4

The relation between the coefficient of performance of a refrigerator $(COP)_R$ and

the coefficient of performance of a heat pump $(COP)_{HP}$ is

- (A) $(COP)_{HP} = (COP)_R + 1$
 (B) $(COP)_{HP} = (COP)_R - 1$
 (C) $(COP)_{HP} = 1 - (COP)_R$
 (D) $(COP)_{HP} \times (COP)_R = 1$

Q.No. 5 If L_1 , L_2 and L_3 are the latent heats of vaporization at the critical temperature of nitrogen, water and ammonia, respectively, then which one of the following is

true?

- (A) $L_1 > L_2 > L_3$
 (B) $L_1 > L_2$ and $L_2 = L_3$
 (C) $L_1 < L_2 < L_3$
 (D) $L_1 = L_2 = L_3$

Q.No. 6 A new temperature scale ($^{\circ}N$) has been proposed where the normal freezing and normal boiling points of water are marked as $500^{\circ}N$ and $100^{\circ}N$, respectively. If the temperature of a system is measured to be $0^{\circ}N$, its temperature according to the Celsius scale (in $^{\circ}C$) is _____.

Q.No. 7 Let Z_1 represents the compressibility factor of air at 2 bar and 600 K, and Z_2 represents the compressibility factor of air at 1 bar and 300 K. If air is assumed to be an ideal gas having gas constant of 0.287 kJ/kg.K, then Z_1/Z_2 is _____.

Q.No. 8 The rate of heat received by a heat engine from a source at 900 K is 600 kJ/s. The engine rejects heat to the sink of 300 K. The heat engine produces a power of 200 kW. The irreversibility rate (in kW) of the process is _____.

Q.No. 9 An engine working on the air standard Diesel cycle has a compression ratio of 18 . The cycle has a cut-off ratio of 1.7 . If the ratio of specific heats of air is 1.4 , then the thermal efficiency (in %) of the cycle (rounded off to 1 decimal place) is _____.

Q10 - Q22 carry two marks each.

Q.No. 10 A system with rigid walls is initially at a temperature of T_1 . It is used as the heat source for a heat engine, which rejects heat to a reservoir maintained at T_0 ($T_0 < T_1$). The specific heats of the system are constant. If the temperature of the system finally reduces to T_0 , then the maximum work recoverable from the heat engine per unit mass of the system is

- (A) $c_v \left[(T_1 - T_0) - T_0 \ln \left(\frac{T_1}{T_0} \right) \right]$
 (B) $c_v (T_1 - T_0)$
 (C) $c_v T_0 \ln \left(\frac{T_1}{T_0} \right)$
 (D) $c_v \frac{T_1^2}{T_0}$

Q.No. 11 A reversible heat engine is operating between two reservoirs maintained at T_1 and T_2 , where $T_1 > T_2$. Which one of the following is the most effective option for increasing its thermal efficiency?

- (A) increasing T_1 , while keeping T_2 constant
 (B) decreasing T_1 , while keeping T_2 constant

- (C) increasing T_2 , while keeping T_1 constant
(D) decreasing T_2 , while keeping T_1 constant

Q.No. 12 A 4-m^3 reservoir contains 10 kg of a real gas at 200 K. If this gas follows the van der Waal's equation of state with $a = 0.0687 \text{ m}^6\cdot\text{kPa}/\text{kg}^2$, $b = 0.00657 \text{ m}^3/\text{kg}$ and $R = 0.187 \text{ kJ}/\text{kg}\cdot\text{K}$, then the reservoir pressure (in kPa) is

- (A) 93.5
(B) 94.6
(C) 95.7
(D) 101.3

Q.No. 13 Air at a pressure of 86 kPa and specific volume of $1 \text{ m}^3/\text{kg}$ is heated at constant pressure till it reaches 627°C . Air is assumed to be an ideal gas with constant specific heats. It has the gas constant of $0.287 \text{ kJ}/\text{kg}\cdot\text{K}$ and ratio of specific heats of 1.4. The change in specific entropy of air (in $\text{kJ}/\text{kg}\cdot\text{K}$) during this process will be

- (A) 1.104
(B) 0.740
(C) 0.788
(D) 0.529

Q.No. 14 An air standard Otto cycle has compression ratio of 4. The compression ratio of this cycle is changed to 6. If the ratio of specific heats is 1.4, the percentage increase in its thermal efficiency will be

- (A) 20.2
(B) 27.2
(C) 42.6
(D) 51.2

Q.No. 15 In a mixture of gas there are 0.1 kmol of oxygen (O_2), 0.1 kmol of nitrogen (N_2) and 0.8 kmol of methane (CH_4). If the molar mass of O_2 , N_2 and CH_4 are 32 kg/kmol , 28 kg/kmol and 16 kg/kmol , respectively, then the mass fraction of N_2 in the gas mixture is

- (A) 0.100
(B) 0.170
(C) 0.148
(D) 0.680

Q.No. 16 A particular gas sample is initially maintained at 6000 cm^3 and 100 kPa. It is compressed during a quasistatic process following the relation $PV^2 = \text{constant}$. The compression continues till the volume becomes 2000 cm^3 . The magnitude of the corresponding work transfer (in kJ) (rounded off to 2 decimal places) is _____.

Q.No. 17 Carbon dioxide (CO_2) enters an adiabatic rigid nozzle steadily at 1 MPa and 500°C with a mass flow rate of 1.5 kg/s. The inlet area of the nozzle is 40 cm^2 and the exit velocity is 10 times of that at the inlet. If CO_2 can be considered as an ideal gas with gas constant of $0.19 \text{ kJ}/\text{kg}\cdot\text{K}$ and the ratio of specific heats of 1.29, the exit temperature (in K) (rounded off to 1 decimal place) is _____.

Q.No. 18

A closed system containing 8 kg of gas undergoes an expansion process following the relation $PV^{1.2} = \text{constant}$. The initial and final pressures are 1 MPa and 5 kPa, respectively, while the initial volume is 1 m^3 . If the specific internal energy of the gas decreases by 40 kJ/kg during the process, the heat transfer (in kJ) associated with the process (rounded off to 1 decimal place) is _____.

- Q.No. 19 Saturation pressure of water at 5°C is 0.8725 kPa. If the latent heat of vaporization is 2489.1 kJ/kg and gas constant is 0.4615 kJ/kg.K, then the saturation pressure at 10°C (in kPa) (rounded off to 2 decimal places) is _____.
- Q.No. 20 The turbine inlet conditions of a Rankine cycle are 10 MPa and 500°C , while the condenser pressure is 10 kPa. The enthalpy and entropy of saturated liquid at 10 kPa are 191.8 kJ/kg and 0.6492 kJ/kg.K, respectively, while the enthalpy and entropy of vapourization at 10 kPa are 2392.1 kJ/kg and 7.4996 kJ/kg.K, respectively. The enthalpy and entropy at the inlet to the turbine are 3375.1 kJ/kg and 6.5995 kJ/kg.K, respectively. The condenser outlet has saturated liquid. Neglecting the pump work, the thermal efficiency (in %) of the cycle (rounded off to 1 decimal place) is _____.
- Q.No. 21 The minimum and maximum temperatures of an air standard Brayton cycle are 300 K and 1100 K, respectively. The pressure ratio of this cycle is 6. The ratio of specific heats is 1.4 and the specific heats are constant. For this cycle, the ratio of network output to the turbine work (rounded off to 2 decimal places) is _____.
- Q.No. 22 The specific humidity of air at 100 kPa is 0.015 kg of vapour per kg of dry air. The partial pressure of vapour (in kPa) in the existing state (rounded off to 2 decimal places) is _____.

XE: Engineering Sciences - F: Polymer Science And Engineering

Q1 - Q9 carry one mark each.

- Q.No. 1 The solvent in which chain transfer is maximum in a radical polymerization is
- (A) Benzene
 - (B) Chloroform
 - (C) Carbon tetrachloride
 - (D) Toluene
- Q.No. 2 The monomer that can NOT be polymerized by anionic polymerization is
- (A) Styrene
 - (B) Ethyl vinyl ether
 - (C) Butadiene
 - (D) Methyl methacrylate
- Q.No. 3 The elastomer retaining flexibility at the lowest temperature is
- (A) Styrene butadiene rubber
 - (B) Nitrile rubber
 - (C) Silicone rubber
 - (D) Butyl rubber
- Q.No. 4 The polymer with minimum number of branches is
- (A) LDPE
 - (B) LLDPE
 - (C) HDPE
 - (D) VLDPE

- Q.No. 5 The nearest value of conductivity of Nylon 6 is
 (A) 10^6 S/m
 (B) 10^0 S/m
 (C) 10^{-13} S/m
 (D) 10^{-21} S/m
- Q.No. 6 Aramid is a
 (A) Polyamide
 (B) Polyether
 (C) Polyester
 (D) Polyimide
- Q.No. 7 A miscible blend in 1:1 (by weight) composition is formed with
 (A) Polystyrene and polybutadiene
 (B) Polystyrene and poly(phenylene oxide)
 (C) Polystyrene and poly(methyl methacrylate)
 (D) Polystyrene and poly(dimethyl siloxane)
- Q.No. 8 Dicumyl peroxide is a
 (A) Plasticizer
 (B) Cross-linking agent
 (C) Mold release agent
 (D) Peptizer
- Q.No. 9 The change in stress of a polymer as a function of time at a fixed strain is known as
 (A) Fatigue
 (B) Creep
 (C) Stress relaxation
 (D) Fracture toughness

Q10 - Q22 carry two marks each.

- Q.No. 10 Match the polymers in Column A with their corresponding polymerization methods in Column B

Column A		Column B	
P	Bisphenol A polycarbonate	1	Cationic
Q	Polyethylene	2	Step-growth
R	Poly(styrene-b-butadiene)	3	Coordination
S	Butyl rubber	4	Anionic

- (A) P-3, Q-2, R-4, S-1
 (B) P-4, Q-3, R-2, S-1
 (C) P-2, Q-3, R-4, S-1
 (D) P-1, Q-3, R-4, S-2

- Q.No. 11

Match the appropriate processing technique in Column A to fabricate the product in Column B

Column A		Column B	
P	Blow molding	1	Plastic buckets
Q	Rotational molding	2	PVC sheet
R	Injection molding	3	Basket ball
S	Calendering	4	Plastic bottles

- (A) P-2, Q-3, R-4, S-1
 (B) P-3, Q-4, R-2, S-1
 (C) P-4, Q-2, R-1, S-3
 (D) P-4, Q-3, R-1, S-2

Q.No. 12 Match the appropriate characterization technique in Column A used to determine the polymer attributes in Column B

Column A		Column B	
P	Gel permeation chromatography	1	Functional group
Q	FT-IR spectroscopy	2	Crystal structure
R	Differential scanning calorimetry	3	Glass transition temperature
S	X-ray diffraction	4	Molecular weight

- (A) P-2, Q-3, R-4, S-1
 (B) P-3, Q-4, R-1, S-2
 (C) P-2, Q-4, R-1, S-3
 (D) P-4, Q-1, R-3, S-2

Q.No. 13 Match each additive in Column A with its function given in Column B

Column A		Column B	
P	Azodiformamide	1	Curing agent
Q	Di-octyl phthalate	2	UV stabilizer
R	Benzoyl peroxide	3	Blowing agent
S	2-(2'-hydroxy phenyl)benzotriazole	4	Plasticizer

- (A) P-2, Q-3, R-1, S-2

- (B) P-3, Q-4, R-1, S-2
 (C) P-4, Q-3, R-2, S-1
 (D) P-1, Q-3, R-4, S-2

Q.No. 14 Plot of shear stress against shear rate for various types of fluids is given below. The appropriate assignment for P, Q, R and S is

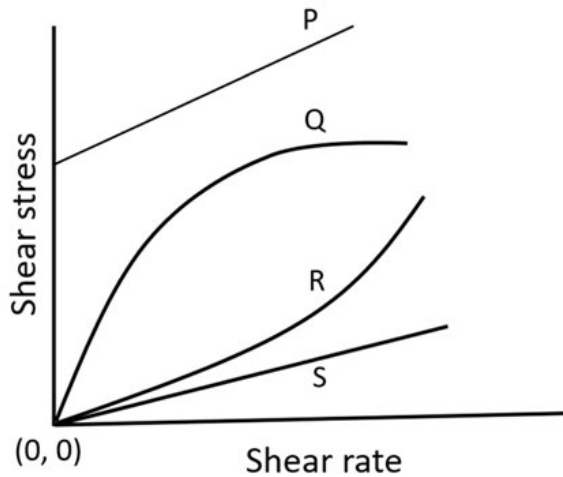

- (A) P-Dilatant, Q-Bingham plastic, R-Pseudoplastic, S-Newtonian
 (B) P-Bingham plastic, Q-Pseudoplastic, R-Dilatant, S-Newtonian
 (C) P-Pseudoplastic, Q-Bingham plastic, R-Newtonian, S-Dilatant
 (D) P-Newtonian, Q-Dilatant, R-Pseudoplastic, S-Bingham plastic

Q.No. 15 The number average molecular weight of a polyester formed from equimolar mixture of adipic acid and ethylene glycol at a conversion of 99.5% will be _____ (round off to nearest integer).

Q.No. 16 For a freely jointed linear polyethylene chain with molar mass of $1.4 \times 10^5 \text{ g mol}^{-1}$, the value of root mean square end-to-end distance in nanometer is _____ (round off to 1 decimal place). [Given: C-C bond length = 0.154 nanometer]

Q.No. 17 Viscosity measurements were performed for a set of PMMA solutions of different concentrations in toluene at 25 °C. The plot of reduced viscosity against concentration (c) of the PMMA solutions produced an intercept of $21.0 \text{ cm}^3 \text{ g}^{-1}$ on the ordinate at $c = 0$. The value of viscosity average molecular weight of PMMA in toluene at 25 °C is _____ (round off to nearest integer). [Given: Mark-Houwink constants $K = 7.5 \times 10^{-3} \text{ cm}^3 \text{ g}^{-1}$ and $a = 0.72$ for PMMA in toluene at 25 °C]

Q.No. 18 Glass fibre reinforced PP composite is to be prepared with 20 volume % of glass fibre. The densities of glass fibre and PP are 2540 kg m^{-3} and 900 kg m^{-3} , respectively. The mass of glass fibre required to produce 1 kg of the composite in kg is _____ (round off to 2 decimal places).

Q.No. 19 A polymer solution flows through a cylindrical tube with a diameter of 4 mm at a volumetric flow rate of $10^{-9} \text{ m}^3 \text{ s}^{-1}$. Under laminar flow condition and assuming the polymer solution to be a Newtonian fluid with viscosity 10^2 N s m^{-2} , the value of pressure drop per unit length of the tube in N m^{-3} is _____ (round off to nearest integer). [Consider the value of π as 3.14]

Q.No. 20

A molten polymer with a bulk modulus of 1 GPa is pressurized to 200 MPa during injection molding. The fractional decrease in volume of the molten polymer at this pressurized condition is _____ (round off to 1 decimal place).

Q.No. 21 Assume that each cross-link produced by vulcanization of polyisoprene contains an average of two sulphur atoms and that the sulphur is present only in the cross-links. If 40% of the isoprene units are cross-linked, the sulphur content in weight percentage is _____ (round off to 2 decimal places).

Q.No. 22 A tensile force of 160 N is applied to a piece of vulcanized rubber of dimension $30 \text{ mm} \times 4 \text{ mm} \times 4 \text{ mm}$. Assuming the vulcanized rubber to be incompressible, if the sample is elongated to 150% of its original length under the same applied force, the true stress in N mm^{-2} will be _____ (round off to 1 decimal place).

XE: Engineering Sciences - G: Food Technology

Q1 - Q9 carry one mark each.

Q.No. 1 The enzyme majorly involved in postmortem degradation of muscle proteins is

- (A) Trypsin
- (B) Calpin
- (C) Transglutaminase
- (D) Pepsin

Q.No. 2 Which of the following is the correct pair of essential fatty acids?

- (A) Oleic acid and Lenoleic acid
- (B) Lenoleic acid and Linolenic acid
- (C) Linolenic acid and Lauric acid
- (D) Linolenic acid and Oleic acid

Q.No. 3 Nisin A is produced by

- (A) *Aspergillus niger*
- (B) *Acetobacter aceti*
- (C) *Lactobacillus lactis*
- (D) *Clostridium perfringens*

Q.No. 4 Which of the following bacteria will stain purple color after Gram staining?

- (A) *Bacillus subtilis*
- (B) *Escherichia coli*
- (C) *Pseudomonas aeruginaosa*
- (D) *Yersinia pestis*

Q.No. 5 The enzyme system used for removal of glucose from egg white prior to its drying consists of

- (A) Glucose oxidase and Catalase
- (B) Glucosidase and Glucoisomerase
- (C) Glucoisomerase and Catalase
- (D) Glucoamylase and Glucose oxidase

Q.No. 6 The **INCORRECT** pair of food borne illness and its causative microorganism is

- (A) Brucellosis – *Brucella* Sp.
- (B) Peptic ulcers – *Bacillus subtilis*
- (C) Bubonic plague - *Yersinia pestis*
- (D) Q fever – *Coxiella burnatii*

Q.No. 7 Which of the following is commonly used as a preservative in the tomato sauce?

- (A) Sodium sulphite
- (B) Potassium sorbate
- (C) Potassium sulphite
- (D) Sodium benzoate

Q.No. 8

The velocity of 2.2 μm diameter fat particles inside a centrifuge, running at 6000 rpm and 20 $^{\circ}\text{C}$, is 0.25 mm s^{-1} . The velocity of 1.5 μm diameter fat particles inside the same centrifuge running at 7500 rpm and same temperature (round off to 2 decimal places) will be _____ mm s^{-1} .

- Q.No. 9 The initial population of a bacterial strain increases from 1×10^4 cells per mL to 1×10^6 cells per mL in 120 minutes. The generation time for this strain (round off to 2 decimal places) is _____ minutes.

Q10 - Q22 carry two marks each.

- Q.No. 10 Match the protein in **Column I** with its food source in **Column II**.

	Column I	Column II
	P. Zein	1. Soybean
	Q. Gluten	2. Maize
	R. Glycinin	3. Egg
	S. Ovalbumin	4. Wheat
(A)	P-4, Q-1, R-2, S-3	
(B)	P-4, Q-3, R-1, S-2	
(C)	P-2, Q-3, R-1, S-4	
(D)	P-2, Q-4, R-1, S-3	

- Q.No. 11 Match the carbohydrate in **Column I** with corresponding enzyme used for its hydrolysis in **Column II**.

	Column I	Column II
	P. Pectin	1. Xylanase
	Q. Lactose	2. β -galactosidase
	R. Hemicellulose	3. Polygalacturonase
	S. Inulin	4. β -fructofuranosidase
(A)	P-3, Q-2, R-1, S-4	
(B)	P-2, Q-4, R-1, S-3	
(C)	P-1, Q-2, R-3, S-4	
(D)	P-4, Q-3, R-1, S-2	

- Q.No. 12 Match the edible oil refining stage in **Column I** with its purpose in **Column II**.

	Column I	Column II
	P. Degumming	1. Separation of triglycerides
	Q. Neutralization	2. Removal of pigments
	R. Bleaching	3. Removal of phosphatides
	S. Winterization	4. Removal of free fatty acids
(A)	P-3, Q-1, R-2, S-4	
(B)	P-1, Q-4, R-2, S-3	
(C)	P-4, Q-3, R-1, S-2	
(D)	P-3, Q-4, R-2, S-1	

- Q.No. 13 Match the food material in **Column I** with its related term in **Column II**.

Column I	Column II
P. Coffee	1. Wort
Q. Cocoa	2. Must
R. Beer	3. <i>Arabica</i>
S. Wine	4. <i>Theobroma</i>

- (A) P-4, Q-2, R-1, S-3
 (B) P-3, Q-4, R-1, S-2
 (C) P-3, Q-4, R-2, S-1
 (D) P-1, Q-3, R-4, S-2

Q.No. 14 Match the component/system in **Column I** with the peeling method for fruits and vegetables in **Column II**.

Column I

- P. Lye solution
 Q. Carborundum rollers
 R. Pressure vessel
 S. Conveyor belt

Column II

1. Flash peeling
 2. Flame peeling
 3. Abrasion peeling
 4. Caustic peeling

- (A) P-4, Q-3, R-2, S-1
 (B) P-3, Q-4, R-1, S-2
 (C) P-4, Q-3, R-1, S-2
 (D) P-3, Q-4, R-2, S-1

Q.No. 15 Which among the given options correctly explains the nature of the microbial culture represented by curves 1, 2 and 3 in the following figure?

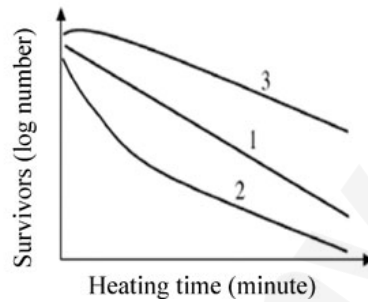

- (A)

1. Germination of spores
2. Homogeneous population
3. Mixed population of spores and vegetative cells
- (B)

1. Homogeneous population
2. Mixed population of heat sensitive and heat resistant microbes
3. Germination of spores
- (C)

1. Composite population
2. Spores activated by short exposure to heat
3. Thermo sensitive and thermo resistant microbes
- (D)

1. Mixed population
2. Microorganisms activated by short exposure to heat
3. Germination of spores

Q.No. 16

Match the equation/law in **Column I** with its application in **Column II**.

Column I**Column II**

- | | |
|---|-------------------------------|
| P. Plank's equation | 1. Terminal velocity |
| Q. Arrhenius equation | 2. Freezing time |
| R. Guggenheim-Anderson-de Boer equation | 3. Activation energy |
| S. Stoke's law | 4. Monolayer moisture content |

- (A) P-1, Q-3, R-4, S-2
 (B) P-2, Q-3, R-1, S-4
 (C) P-2, Q-3, R-4, S-1
 (D) P-4, Q-3, R-1, S-2

Q.No. 17 Match the absorber used in modified atmosphere packaging and storage in **Column I** with the scavenger in **Column II**.

Column I**Column II**

- | | |
|----------------------------|---------------------------|
| P. Oxygen absorber | 1. Calcium chloride |
| Q. Carbon dioxide absorber | 2. Magnesium oxide |
| R. Ethylene absorber | 3. Ferric oxide |
| S. Moisture absorber | 4. Potassium permanganate |

- (A) P-3, Q-2, R-4, S-1
 (B) P-1, Q-2, R-4, S-3
 (C) P-2, Q-3, R-4, S-1
 (D) P-3, Q-2, R-1, S-4

Q.No. 18 During extrusion cooking, food materials are generally subjected to a combination of
 (A) high shear and low pressure
 (B) high temperature and high shear
 (C) low shear and high temperature
 (D) low shear and low pressure

Q.No. 19 The whole milk at 22 °C is pumped through a stainless steel pipe at a flow rate of 3 L s⁻¹. The length and inner diameter of the pipe are 40 m and 4 cm, respectively. If viscosity and density of the milk at the pumping temperature of 0.2 Pa s and 1032 kg m⁻³, respectively, the Reynolds number (rounded off to nearest integer) will be _____.

Q.No. 20 A hammer mill, operating at a feed rate of 108 ton h⁻¹, consumes 10 kW power for reducing size of wheat grain from 3.92 mm to 1.25 mm. If Bond's law holds good, the feed rate (round off to 2 decimal places) for reducing the size of the wheat grain to 0.75 mm at the same power consumption level is _____ ton h⁻¹.

Q.No. 21 During spray drying of a milk sample, inlet and outlet temperatures are maintained at 132 °C and 80 °C, respectively. If the ambient temperature is 29 °C, the thermal efficiency (round off to 2 decimal places) of the dryer will be _____ %.

Q.No. 22 An orange juice flowing at 0.80 kg s⁻¹ enters a counter current double pipe heat exchanger at 20 °C and leaves at 72 °C. Inlet and outlet temperatures of the hot water used as heating medium in the exchanger are 81 °C and 74 °C, respectively. The specific heat of the orange juice is 3.74 kJ kg⁻¹ K⁻¹ and overall heat transfer coefficient is 492 W m⁻² K⁻¹. The heat transfer surface area (round off to 2 decimal places) will be _____ m².

XE: Engineering Sciences - H: Atmospheric and Oceanic Sciences
Q1 - Q9 carry one mark each.

- Q.No. 1 In the northern hemisphere, the flow in the middle depths of the ocean is geostrophic. As we go down from that level and start approaching the bottom of the ocean, the flow deflects to the left of the geostrophic current because
- (A) friction decreases and Coriolis force increases
 (B) friction decreases and Coriolis force decreases
 (C) friction increases and Coriolis force increases
 (D) friction increases and Coriolis force decreases
- Q.No. 2 Which one of the following is the definition of a monsoon?
- (A) Seasonal reversal of wind direction
 (B) High rainfall
 (C) Occurs in the summer
 (D) Occurs in the tropics
- Q.No. 3 Anthropogenic emission of _____ is the main contributor to the ongoing ocean acidification.
- (A) Methane
 (B) Carbon dioxide
 (C) Nitrous oxide
 (D) Sulphuric acid
- Q.No. 4 What are phytoplankton?
- (A) Microscopic animal life floating on surface of water bodies
 (B) Pollen floating freely on surface of water bodies
 (C) Microscopic plant life floating on surface of water bodies
 (D) Microscopic plant life living on the floor of water bodies
- Q.No. 5 Consider the two atmospheric virtual temperature profiles observed in Delhi given in Figures (i) and (ii) below.

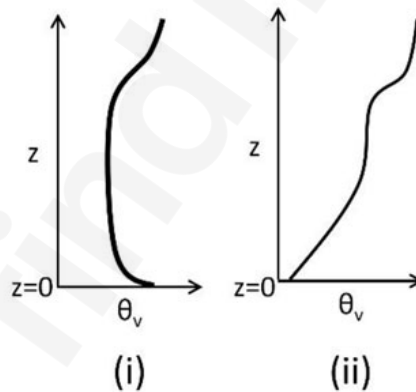

At what times of the day are you most likely to see such profiles?

- (A) (i) Midnight and (ii) noon
 (B) (i) 3 pm and (ii) 3 am
 (C) (i) Sunrise and (ii) sunset
 (D) (i) 3 am and (ii) 3 pm
- Q.No. 6 A south-easterly wind is blowing towards which direction?
- (A) 135°
 (B) 157.5°
 (C) 315°
 (D) 225°

Q.No. 7

Consider a dry parcel at 30 °C in an isothermal environment at 25 °C. The parcel rises adiabatically by 1 km. Assuming $g = 10 \text{ ms}^{-2}$ and air density = 1 kgm^{-3} , the buoyancy force at the new location (rounded off to 2 decimal places) is _____ ms^{-2} .

- Q.No. 8 The emissivity of polluted air that reflects and transmits 20% and 60% of the incoming solar radiation, respectively, at a given wavelength (correct up to 1 decimal place) is _____.
- Q.No. 9 Given that the angular velocity of rotation of the Earth = $7.3 \times 10^{-5} \text{ s}^{-1}$, the period of inertial oscillations generated in the oceans by surface winds at 30° N latitude (rounded off to the nearest integer) is _____ hours.

Q10 - Q22 carry two marks each.

- Q.No. 10 Consider a high pressure centre in the northern hemisphere with tangential winds of 10 ms^{-1} at a distance of 500 km from the centre. Assuming solid body rotation principles, what is the relative vorticity of the flow?
- (A) $2 \times 10^{-5} \text{ s}^{-1}$
 (B) $-2 \times 10^{-5} \text{ s}^{-1}$
 (C) $4 \times 10^{-5} \text{ s}^{-1}$
 (D) $-4 \times 10^{-5} \text{ s}^{-1}$
- Q.No. 11 Which one of the following statements is true for atmospheric and oceanic general circulation models?
- (A) Vertical velocity is ignored in oceanic models but not in atmospheric models.
 (B) Boussinesq approximation is adequate in oceanic models but not in atmospheric models.
 (C) Atmospheric models need a longer spin-up and integration time than oceanic models.
 (D) Atmospheric models need parameterizations for subgrid scale processes but oceanic models do not.
- Q.No. 12 Consider a scenario where air temperature increases by 2 °C. We know that saturation vapour pressure for water increases with temperature. As a result of this effect, the water vapour content of the atmosphere will _____ and the net warming will be _____ than 2 °C. The correct pair of words to fill in the blanks (in the right order) is
- (A) increase, more
 (B) increase, less
 (C) decrease, more
 (D) decrease, less
- Q.No. 13 The prevailing Trade winds over the Equator in the Pacific Ocean result in piling up of waters in the _____ part of the ocean. As a result, the gradients of the thermocline and the ocean surface have _____ signs. The correct pair of words to fill in the blanks (in the right order) is
- (A) western, opposite
 (B) western, same
 (C) eastern, opposite
 (D) eastern, same
- Q.No. 14

Consider two different cases, shown in Figures (i) and (ii) below, with two layers of water of same density on top of each other.

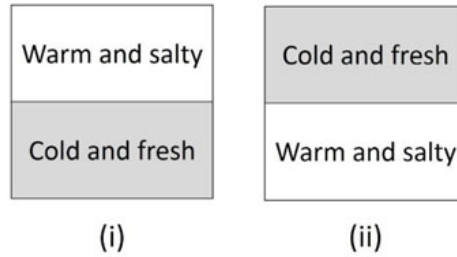

Which one of the following statements is true about convective plumes across the interface of the two layers?

- (A) Upward convective plumes in (i) and downward convective plumes in (ii)
- (B) Downward convective plumes in (i) and upward convective plumes in (ii)
- (C) No convective plume in (i) and (ii)
- (D) No convective plume in (i) but upward convective plumes in (ii)

Q.No. 15 During the Indian summer monsoon, surface outgoing longwave radiation (OLR)

over the Arabian Sea is often observed to be low because

- (A) of enhanced convection
- (B) monsoon winds advect the OLR away into the Indian subcontinent
- (C) monsoon clouds limit incoming solar radiation
- (D) surface Bowen ratio is low

Q.No. 16 A tsunami wave in the ocean is approaching the coast. Assuming $g = 10 \text{ ms}^{-2}$, the correct group speed of the wave at a depth of 1 km is

- (A) 1 ms^{-1}
- (B) 10 ms^{-1}
- (C) 100 ms^{-1}
- (D) 1000 ms^{-1}

Q.No. 17 A tornado is in cyclostrophic balance where the horizontal pressure gradient and centrifugal forces balance each other. Consider a tornado with 100 m radius and a tangential velocity of 100 ms^{-1} at the edge. Assuming air density = 1 kgm^{-3} , the magnitude of the pressure-drop between the centre and the edge of the tornado is _____ $\text{kgm}^{-1} \text{ s}^{-2}$.

Q.No. 18 While driving south a distance of 1000 km, the temperature outside your car increases from 10°C to 20°C . Assuming the air is completely dry, $g = 10 \text{ ms}^{-2}$ and Coriolis parameter = 10^{-4} s^{-1} , the vertical gradient of the geostrophic wind (rounded off to 2 decimal places) is _____ $\text{ms}^{-1} \text{ km}^{-1}$.

Q.No. 19 A westerly wind of 10 ms^{-1} is blowing at a location in the Pacific Ocean in the northern hemisphere. Assuming density of sea water = 1000 kgm^{-3} , Coriolis parameter = 10^{-4} s^{-1} and drag coefficient for sea water = 10^{-6} , the Ekman transport due to the wind at that location is _____ $\text{kgm}^{-1} \text{ s}^{-1}$.

Q.No. 20 M_x and M_y represent the ocean mass transport in the x and y directions, respectively. L_x and L_y are the corresponding east-west and north-south length scales. For a typical equatorial ocean gyre, if the ratio of zonal to meridional mass transport ≈ 10 , then $L_x \approx$ _____ L_y .

Q.No. 21

Assume that pressure varies exponentially with height: $p(z) = p_0 e^{-z/H}$, where $p(z)$ is the pressure at a height z above the surface, p_0 is the surface pressure, and the scale height $H = 7.5$ km. Under these conditions, one-fourth of the total mass of the atmosphere lies above a height (rounded off to 1 decimal place) of _____ km above the surface.

- Q.No. 22 Consider an atmospheric column of depth 300 m at the Earth's surface with an average temperature of 300 K. If the temperature of the layer rises by $\Delta T = 10$ °C, the layer depth h will increase by Δh . Assuming $\Delta T/T \approx \Delta h/h$, air density remains unchanged at 1 kgm^{-3} and $g = 10 \text{ ms}^{-2}$, the change in surface pressure is _____ $\text{kgm}^{-1}\text{s}^{-2}$.



find my college