

PI: Production and Industrial Engineering

GA - General Aptitude

Q1 - Q5 carry one mark each.

Q.No. 1 While I agree _____ his proposal this time, I do not often agree _____ him.

- (A) to, with
- (B) with, to
- (C) with, with
- (D) to, to

Q.No. 2 The recent measures to improve the output would _____ the level of production to our satisfaction.

- (A) increase
- (B) decrease
- (C) speed
- (D) equalise

Q.No. 3 Select the word that fits the analogy:

White: Whitening :: Light: _____

- (A) Lightning
- (B) Lightening
- (C) Lighting
- (D) Enlightening

Q.No. 4 In one of the greatest innings ever seen in 142 years of Test history, Ben Stokes upped the tempo in a five-and-a-half hour long stay of 219 balls including 11 fours and 8 sixes that saw him finish on a 135 not out as England squared the five-match series.

Based on their connotations in the given passage, which one of the following meanings DOES NOT match?

- (A) upped = increased
- (B) squared = lost
- (C) tempo = enthusiasm
- (D) saw = resulted in

Q.No. 5 There are five levels {P, Q, R, S, T} in a linear supply chain before a product reaches customers, as shown in the figure.

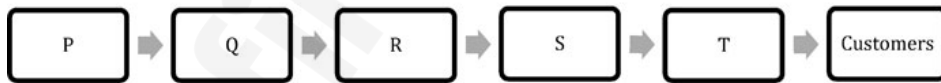

At each of the five levels, the price of the product is increased by 25%. If the product is produced at level P at the cost of Rs. 120 per unit, what is the price paid (in rupees) by the customers?

- (A) 187.50
- (B) 234.38
- (C) 292.96
- (D) 366.21

Q6 - Q10 carry two marks each.

Q.No. 6 Climate change and resilience deal with two aspects – reduction of sources of non-renewable energy resources and reducing vulnerability of climate change aspects. The terms ‘mitigation’ and ‘adaptation’ are used to refer to these aspects, respectively.

Which of the following assertions is best supported by the above information?

- (A) Mitigation deals with consequences of climate change.
- (B) Adaptation deals with causes of climate change.
- (C) Mitigation deals with actions taken to reduce the use of fossil fuels.
- (D) Adaptation deals with actions taken to combat green-house gas emissions.

Q.No. 7 Find the missing element in the following figure.

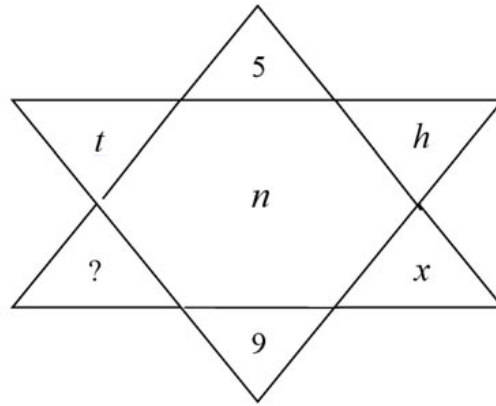

- (A) d
- (B) e
- (C) w
- (D) y

Q.No. 8 It was estimated that 52 men can complete a strip in a newly constructed highway connecting cities P and Q in 10 days. Due to an emergency, 12 men were sent to another project. How many number of days, more than the original estimate, will be required to complete the strip?

- (A) 3 days
- (B) 5 days
- (C) 10 days
- (D) 13 days

Q.No. 9 An engineer measures THREE quantities X, Y and Z in an experiment. She finds that they follow a relationship that is represented in the figure below: (the product of X and Y linearly varies with Z)

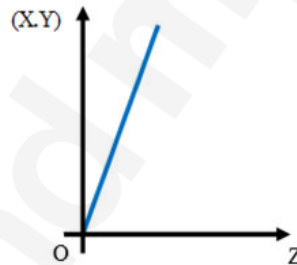

Then, which of the following statements is FALSE?

- (A) For fixed Z; X is proportional to Y
- (B) For fixed Y; X is proportional to Z
- (C) For fixed X; Z is proportional to Y
- (D) XY/Z is constant

Q.No.
10

The two pie-charts given below show the data of total students and only girls registered in different streams in a university. If the total number of students registered in the university is 5000, and the total number of the registered girls is 1500; then, the ratio of boys enrolled in Arts to the girls enrolled in Management is _____.

Percentage of students enrolled in different streams in a University

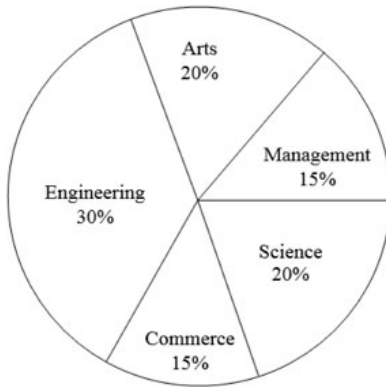

Percentage of girls enrolled in different streams

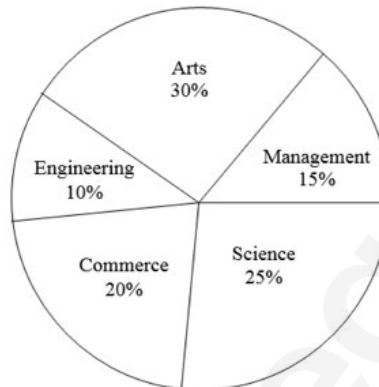

- (A) 2 : 1
 (B) 9 : 22
 (C) 11 : 9
 (D) 22 : 9

PI: Production and Industrial Engineering

Q1 - Q25 carry one mark each.

Q.No. 1 The divergence of the vector $\vec{v} = y^2\hat{i} + z^2\hat{j} + x^2\hat{k}$ is

- (A) $2x$
 (B) $2y$
 (C) $2z$
 (D) 0

Q.No. 2 An integrating factor for the differential equation $\frac{dy}{dx} + my = e^{-mx}$ is

- (A) e^m
 (B) e^{-m}
 (C) e^{-mx}
 (D) e^{mx}

Q.No. 3 For the complex numbers $z_1 = 2 + 3i$ and $z_2 = 4 - 5i$, the value of $(z_1 + z_2)^2$ is

- (A) $32 - 24i$
 (B) $-32 - 24i$
 (C) $32 + 24i$
 (D) $-32 + 24i$

Q.No. 4 To solve $x^2 - 2 = 0$, the Newton-Raphson method has been employed. If the initial guess $x_0 = 1.0$, the next estimate of the root, x_1 , will be

- (A) 0.5
 (B) 1.0
 (C) 1.5
 (D) 2.0

Q.No. 5 If x is a random variable with the expected value of 5 and the variance of 1, then the expected value of x^2 is

- (A) 24
 (B) 25
 (C) 26
 (D) 36

Q.No. 6 Group I lists phases of steel and Group II lists crystal structures in the table below.

Group I	Group II
P. Ferrite	1. Hexagonal Close Packed (HCP)
Q. Austenite	2. Body Centered Cubic (BCC)
R. Martensite	3. Body Centered Tetragonal (BCT)
	4. Face Centered Cubic (FCC)

Match the phase with the corresponding crystal structure.

- (A) P-2, Q-4, R-3
 (B) P-4, Q-2, R-3
 (C) P-2, Q-4, R-1
 (D) P-4, Q-2, R-1

Q.No. 7 The figure shows two bodies P and Q. The body Q is placed on the ground and the body P is placed on top of it. The weights of P and Q are W_P and W_Q , respectively. The bodies are at rest and all the surfaces are assumed to be frictionless. R represents reaction force, if any, between the bodies.

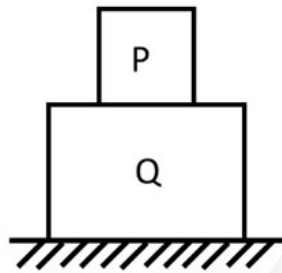

The correct free body diagram of the body P is

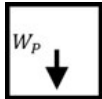
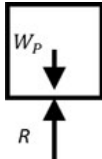
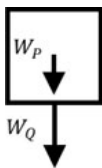
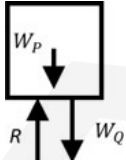
- (A) 
- (B) 
- (C) 
- (D) 

Q.No. 8

The figure shows a mechanism with 3 revolute pairs (between the links 1 and 2, 2 and 3, and 3 and 4) and a prismatic pair (between the links 1 and 4). Which one of the four links should be fixed to obtain the mechanism that forms the basis of the quick-return mechanism widely used in a shaper?

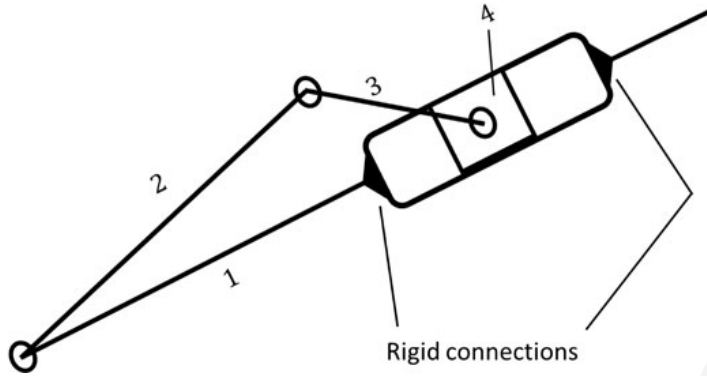

- (A) Link 1
- (B) Link 2
- (C) Link 3
- (D) Link 4

Q.No. 9 The state of stress at a point in a body under plane stress condition is shown in the figure. The positive directions of x and y axes are also shown. The material of the body is homogeneous and isotropic, with modulus of elasticity E and Poisson's ratio ν . The longitudinal strain in the x -direction is

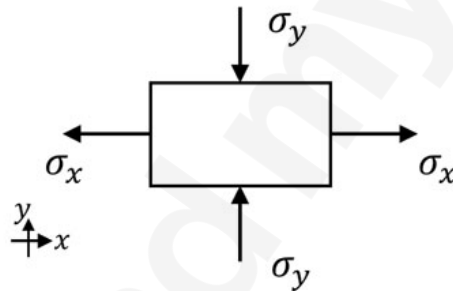

- (A) $\frac{\sigma_x}{E} - \nu \frac{\sigma_y}{E}$
- (B) $-\frac{\sigma_x}{E} - \nu \frac{\sigma_y}{E}$
- (C) $\frac{\sigma_x}{E} + \nu \frac{\sigma_y}{E}$
- (D) $-\frac{\sigma_x}{E} + \nu \frac{\sigma_y}{E}$

Q.No. 10

The figure shows two bodies connected through a riveted joint with one rivet. The diameter of the rivet is d (in m). The joint transmits a load of F (in N) whose line of action is perpendicular to and intersects the vertical axis of the rivet. Neglect any effect of bending of the rivet. If the allowable shear stress for the material of the rivet is τ N/m², the diameter of the rivet required to prevent failure in shear is

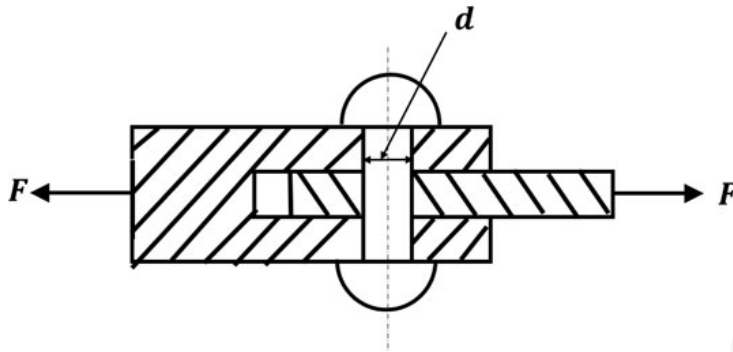

- (A) $\sqrt{\frac{F}{\pi \tau}}$
 (B) $\sqrt{\frac{2F}{\pi \tau}}$
 (C) $\sqrt{\frac{4F}{\pi \tau}}$
 (D) $\sqrt{\frac{8F}{\pi \tau}}$

Q.No. 11 Consider flow of an oil with Reynolds number 1500 in a pipe of diameter 5 cm.

The kinematic viscosity of the oil, $\nu = 0.75$ cm²/s. The value of average velocity in m/s is

- (A) 0.75
 (B) 1.50
 (C) 2.25
 (D) 4.50

Q.No. 12 A Carnot heat engine receives 600 kJ of heat per cycle from a source at 627°C and rejects heat to a sink at 27°C. The amount of heat rejected to the sink per cycle (rounded off to the nearest integer) in kJ is

- (A) 26
 (B) 200
 (C) 400
 (D) 574

Q.No. 13 The process used for producing long bars of fiber reinforced plastics (FRP) with uniform cross-section is

- (A) Extrusion
 (B) Pultrusion
 (C) Injection Molding
 (D) Thermoforming

Q.No. 14 The purpose of the ratchet in a micrometer is to

- (A) impart smooth movement to the spindle
 (B) compensate for the wear of the screw thread
 (C) prevent rotation of the spindle while reading the scale
 (D) maintain sufficient and uniform measuring pressure

Q.No. 15 End mill cutters are mounted on the spindle of a vertical milling machine using

(A) vice
(B) collet
(C) face plate
(D) driver plate

Q.No. 16 Self-sharpening tendency of a conventional grinding wheel depends upon

(A) wheel structure
(B) wheel grade
(C) grit hardness
(D) grit size

Q.No. 17 A non-traditional machining process which utilizes mechanical energy as the principal energy source for removing the material is

(A) Electric discharge machining
(B) Laser beam machining
(C) Ultrasonic machining
(D) Plasma arc machining

Q.No. 18 In manufacturing of self-lubricating bearings by powder metallurgy, an important secondary operation that is carried out after sintering is

(A) Cold isostatic pressing
(B) Hot isostatic pressing
(C) Impregnation
(D) Infiltration

Q.No. 19 Which of the following is a causal forecasting method?

(A) Naive approach
(B) Moving average
(C) Exponential smoothing
(D) Linear regression

Q.No. 20 An approach used in the product development which combines the efforts of design, manufacturing, and other functions to reduce the total time in introducing a new product in the market is

(A) Concurrent engineering
(B) Lean manufacturing
(C) Value engineering
(D) Break-even analysis

Q.No. 21 The Bellman's principle of optimality is related to

(A) Linear programming problem
(B) Transportation problem
(C) Dynamic programming problem
(D) Assignment problem

Q.No. 22 The process capability ratio C_p is given by

(A) $\frac{\text{Upper Specification Limit} - \text{Lower Specification Limit}}{6 \times \text{Process Standard Deviation}}$
(B) $\frac{\text{Upper Control Limit} - \text{Lower Control Limit}}{6 \times \text{Process Standard Deviation}}$
(C) $\frac{\text{Upper Specification Limit} - \text{Lower Specification Limit}}{6 \times \text{Process Standard Deviation}}$
(D) $\frac{\text{Upper Specification Limit} - \text{Lower Specification Limit}}{6 \times \text{Process Standard Deviation}}$
 $\frac{\text{Upper Control Limit} - \text{Lower Control Limit}}{6 \times \text{Process Standard Deviation}}$

Q.No. 23 In a uniaxial tensile test on a specimen of a ductile material, the ultimate tensile strength is found to be 400 MPa and the elongation up to the maximum load is 25%. The true stress at the maximum load in MPa is _____.

Q.No. 24 Suppose the control system of a fighter jet consists of three unrelated components in series, and it is desired to have 98% reliability of the system. If the reliability level of all the components is the same, then the reliability of each component (rounded off to three decimal places) is _____.

Q.No. 25 The product structure tree in the figure below shows the components needed to assemble one unit of product P.

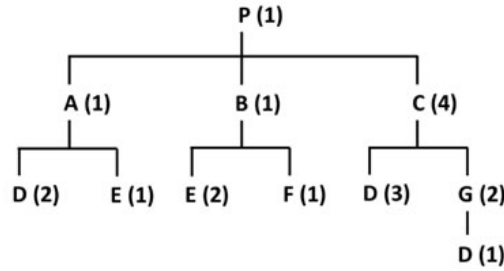

The number of units of component D needed to assemble 10 units of product P is _____.

Q26 - Q55 carry two marks each.

Q.No. 26 General solution of $x^2 \frac{d^2y}{dx^2} + x \frac{dy}{dx} - y = 0$ is

- (A) $y = \frac{C_1}{x} + \frac{C_2}{x^3}$
 (B) $y = C_1x^2 + \frac{C_2}{x^2}$
 (C) $y = C_1x + \frac{C_2}{x}$
 (D) $y = C_1x + C_2x^3$

Q.No. 27 For the matrix $\begin{bmatrix} 1 & 5 \\ 3 & 3 \end{bmatrix}$, the eigenvectors are

- (A) $\begin{bmatrix} 1 \\ -1 \end{bmatrix}$ and $\begin{bmatrix} 3 \\ -3 \end{bmatrix}$
 (B) $\begin{bmatrix} 1 \\ 1 \end{bmatrix}$ and $\begin{bmatrix} -5/3 \\ 1 \end{bmatrix}$
 (C) $\begin{bmatrix} 1 \\ 3 \end{bmatrix}$ and $\begin{bmatrix} 5 \\ 3 \end{bmatrix}$
 (D) $\begin{bmatrix} -1 \\ 1 \end{bmatrix}$ and $\begin{bmatrix} 5/3 \\ 1 \end{bmatrix}$

Q.No. 28

A truss with two bars PR and QR, making angles α and β , respectively, with the vertical, is shown in the figure below. The connections at P, Q and R are hinged connections. The truss supports a body of weight W (in N) at R as shown. The tension in the bar QR (in N) is

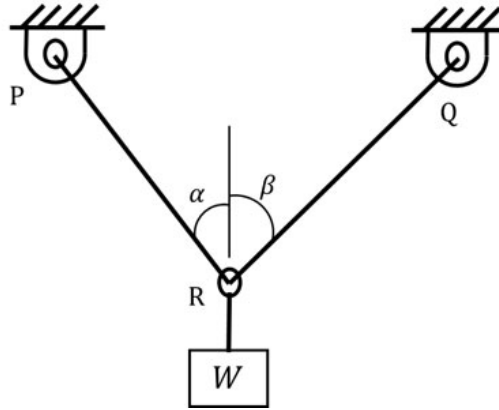

- (A) $\frac{W \sin \beta}{\cos(\alpha + \beta)}$
 (B) $\frac{W \cos \beta}{\sin(\alpha + \beta)}$
 (C) $\frac{W \cos \alpha}{\cos(\alpha + \beta)}$
 (D) $\frac{W \sin \alpha}{\sin(\alpha + \beta)}$

Q.No.
29

The figure shows a beam of length L (in m) with a uniformly distributed transverse load of W (in N/m) acting over it. The width and depth of the beam cross section are b (in m) and t (in m), respectively. The magnitude of the maximum bending stress in the beam in N/m^2 is

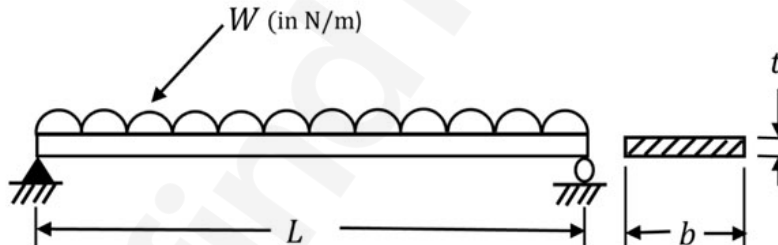

- (A) $\frac{3WL^2}{4bt^2}$
 (B) $\frac{4WL^2}{3bt^2}$
 (C) $\frac{2WL^2}{3bt^2}$
 (D) $\frac{3WL^2}{2bt^2}$

Q.No.
30

The vertices of rectangle $PQRS$ are as follows in a 2-D CAD system.

$$P(-4,-2); Q(-2,-3); R(-3,-5); S(-5,-4)$$

The coordinates of the corresponding new vertices, P' , Q' , R' , S' after translation of the rectangle along x -axis in the positive direction by 6 units and along y -axis in the positive direction by 3 units are

- (A) $P'(-10,-5); Q'(-8,-6); R'(-9,-8); S'(-11,-7)$
 (B) $P'(2,1); Q'(4,0); R'(3,-2); S'(1,-1)$

- (C) $P' (2,-5); Q' (4,-6); R' (3,-8); S' (1,-7)$
 (D) $P' (-10,1); Q' (-8,0); R' (-9,-2); S' (-11,-1)$

Q.No. 31 The statement that best describes the function of a GO gauge in the context of Taylor's principle of gauging is

- (A) GO gauge checks the Maximum Material Condition and is designed to check as many dimensions as possible
 (B) GO gauge checks the Least Material Condition and is designed to check as many dimensions as possible
 (C) GO gauge checks the Maximum Material Condition and is designed to check only one dimension
 (D) GO gauge checks the Least Material Condition and is designed to check only one dimension

Q.No. 32 The figure shows revenue generated over different product life cycle stages marked as P, Q, R and S. Group I lists these product life cycle stages. Group II lists typical efforts leading to revenue maximization during a stage.

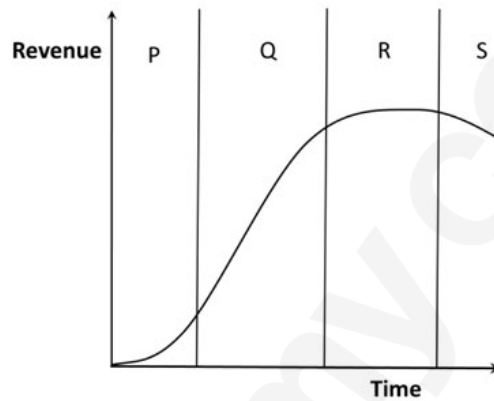

Group I

- P. Introduction
 Q. Growth
 R. Maturity
 S. Decline

Group II

1. Efforts to enhance the production capacity
2. Efforts to rejuvenate the product
3. Efforts to maximize the product performance
4. Efforts to explore other markets

Match the stage with the efforts.

- (A) P-3; Q-4; R-2; S-1
 (B) P-1; Q-4; R-2; S-3
 (C) P-1; Q-3; R-4; S-2
 (D) P-3; Q-1; R-2; S-4

Q.No. 33 A company manufactures products P and Q in quantities x_1 and x_2 , respectively, using two resources. The following Linear Programming Problem (LPP) is formulated to maximize the profit Z.

$$\text{Maximize } Z = 3x_1 + 2x_2$$

$$\text{subject to } x_1 + 2x_2 \leq 2 \quad (\text{for Resource 1})$$

$$2x_1 + x_2 \leq 2 \quad (\text{for Resource 2})$$

$$\text{and } x_1, x_2 \geq 0.$$

The shadow price for Resource 2 is

- (A) 0
 (B) $\frac{2}{3}$
 (C) 1
 (D) $\frac{4}{3}$

Q.No.
34 A rectifying inspection is performed on a lot of size $N = 1000$ using a Single-Sampling Plan with the sample size $n = 60$ and the acceptance number $c = 1$. If the Acceptable Quality Level is 1.0%, the producer's risk associated with the sampling plan (rounded off to the nearest integer) in % is

- (A) 12
- (B) 33
- (C) 67
- (D) 88

Q.No.
35 For $y = -x^2 + 9x - 2$, the value of $\int_1^5 y dx$ using Simpson's $\frac{1}{3}$ rule with two intervals (rounded off to two decimal places) is _____.

Q.No.
36 If the probability density function of a random variable x is given by

$$f(x) = \begin{cases} \frac{kx^2}{2}, & -1 \leq x \leq 1 \\ 0, & \text{elsewhere,} \end{cases}$$

the value of k is _____.

Q.No.
37 A solid shaft has to transmit 50 kW of power at a speed of 1910 RPM. Ignore any possible bending of the shaft. The maximum allowable shear stress for the material of the shaft is 80 MPa. The minimum diameter of the shaft required to prevent failure due to shear (rounded off to one decimal place) in cm is _____.

Q.No.
38 A flywheel is to be used in an IC engine to limit fluctuation of angular speed. The average of the maximum and the minimum angular speed is 500 RPM, and the maximum fluctuation of energy is 10,000 N-m. Neglecting rotary inertia of any other components, the moment of inertia of the flywheel about its axis of rotation required to limit the maximum fluctuation of speed to 30 RPM (rounded off to one decimal place) in kg-m^2 is _____.

Q.No.
39

A tank of large cross-sectional area contains water up to a height of 5 m as shown in the figure. The top water surface is under a pressure of $p_1 = 0.2$ MPa. A small, smooth and round tap at the bottom of the tank is opened to the atmosphere ($p_2 = 0.1$ MPa).

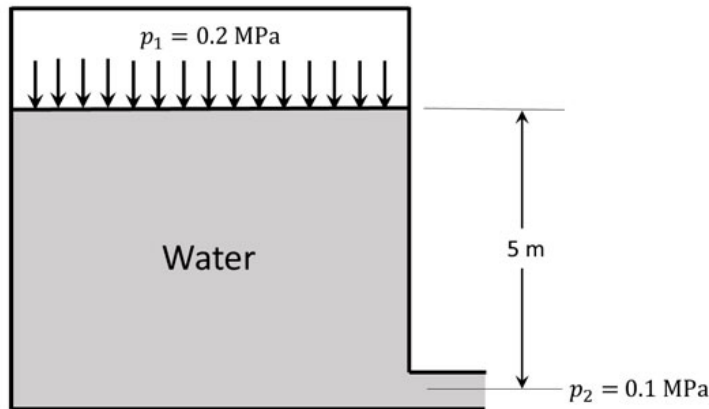

Use the acceleration due to gravity, $g = 9.81$ m/s² and the density of water, $\rho = 1000$ kg/m³. The velocity with which the water will exit from the tap under the conditions shown in the figure (rounded off to one decimal place) in m/s is _____.

Q.No.
40

A steel ball of 12 mm diameter is heated to 1225 K. It is then slowly cooled in air to a temperature of 475 K. During the cooling process, the ambient temperature is 325 K and the heat transfer coefficient is 30 W/m²-K. Assume, the density of steel is 7800 kg/m³ and the specific heat is 600 J/kg-K. Using the lumped capacitance method of analysis, the calculated time for the required cooling (rounded off to one decimal place) in seconds is _____.

Q.No.
41

A mass of 3 kg of Argon gas at 3 bar, 27 °C is contained in a rigid, insulated vessel. Paddle wheel work is done on the gas for 30 minutes at the rate of 0.015 kW. Specific heat at constant volume, C_v , for Argon is 0.3122 kJ/kg-K. The final temperature of the gas (rounded off to one decimal place) in kelvin is _____.

Q.No.
42

The figure shows drawing of a part with dimensions and tolerances, both in mm. The permissible tolerance for slot A (rounded off to one decimal place) in mm is \pm _____.

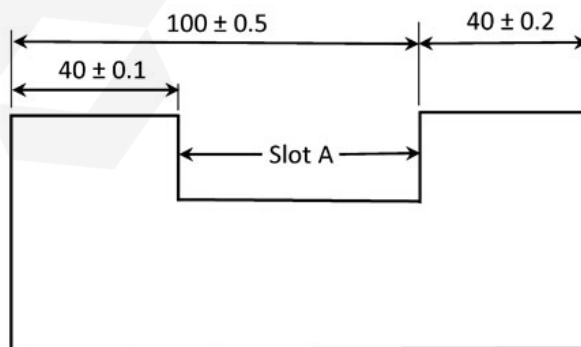

Q.No.
43

To manufacture a product by casting, molten metal is poured in a cavity of rectangular cross section in a sand mold with a side blind riser as shown in the figure. The dimensions of the mold cavity are 60 cm x 40 cm x 20 cm.

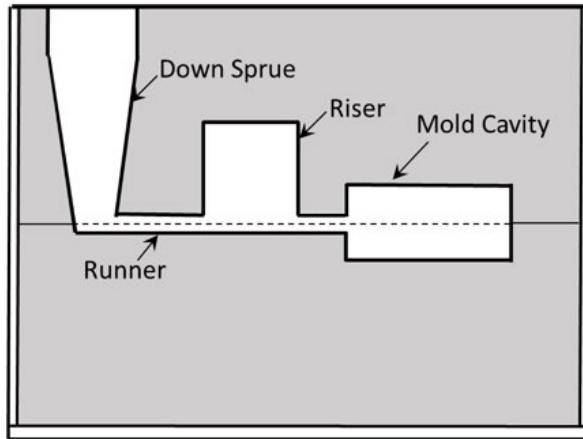

The riser is cylindrical in shape with diameter equal to height. It is required that the solidification time of the riser should be 25% greater than that of the mold. Using Chvorinov's rule, the diameter of the riser (rounded off to one decimal place) in cm should be _____.

Q.No.
44

A cylindrical billet of 90 mm diameter is extruded to produce an I-section as shown in the figure (all dimensions in mm).

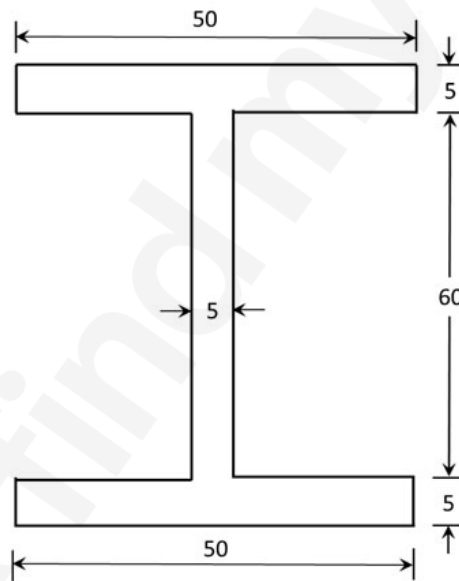

The total extrusion pressure (p_e) in MPa required for the above process is given by

$$p_e = \sigma_m \left[0.8 + 1.2 \ln \left(\frac{A_0}{A_f} \right) \right]$$

where, σ_m is the mean flow stress of the material, and A_0 and A_f are the initial and the final cross-sectional areas, respectively. If the mean flow stress of the extruded material is 80 MPa, the force required for the above extrusion (rounded off to one decimal place) in kN is _____.

Q.No.
45

The heat generated in a resistance spot welding operation for joining two metal sheets with a certain set of process parameters is 2000 J. For a second spot welding operation on the same sheets without any change in the overall resistance of the system, the current is increased by 25% and the time for which the current is applied is reduced to half. The heat generated in the second operation (rounded off to one decimal place) in J is _____.

Q.No.
46

A vertical boring operation is performed in a cast iron plate to enlarge a blind hole to a diameter of 25 mm up to a depth of 100 mm in a single pass. The cutting speed and the feed used in the process are 100 m/min and 0.1 mm/rev, respectively. Considering the allowance for tool approach as 2 mm, the actual machining time (rounded off to two decimal places) in minutes is _____.

Q.No.
47

For a particular tool-workpiece combination, the value of exponent n in Taylor's tool life equation is 0.5. If the cutting speed is reduced by 50% keeping all the other machining conditions same, the increase in tool life in % is _____.

Q.No.
48

In a waterjet machining process, the water pressure used is 500 MPa. The diameter of orifice of the nozzle through which the waterjet comes out is 0.25 mm. Neglecting frictional and other losses, and using the density of water as 1000 kg/m^3 , the mass flow rate of the waterjet (rounded off to two decimal places) in kg/min is _____.

Q.No.
49

The movement along the z -axis of a CNC drilling machine is controlled by using a servo motor, a lead screw and an incremental encoder. The lead screw has 2 threads/cm and it is directly coupled to the servo motor. The incremental encoder attached to the lead screw emits 100 pulses/revolution. The control resolution in microns is _____.

Q.No.
50

A project consists of seven activities as listed in the table. The time required for each activity and its immediate predecessor(s) are also given.

Activity	Time required (in weeks)	Immediate Predecessor(s)
P	7	-
Q	4	-
R	2	Q
S	11	P
T	9	P, R
U	9	Q
V	4	T, U

The project completion time using Critical Path Method (CPM) in weeks is _____.

Q.No.
51

A company is planning to procure a machine to produce a component. There are two alternatives available - machine A and machine B. The cost of producing x units of the component (in Rs.) using machine A is given as $C_A(x) = 10000 + 170x + x^2$. The cost of producing x units of the component (in Rs.) using machine B is given as $C_B(x) = 15000 + 400x$. If machine B is to be preferred, then the minimum number of units to be produced should be _____.

Q.No.
52

The availability of an old photocopier was 90% and the Mean Time Between Failure (MTBF) was 200 days. It has been replaced with a new photocopier having an availability of 95%. Now, the Mean Time to Repair (the time during which the photocopier is unavailable for service) has increased by 5 days. The MTBF of the new photocopier (rounded off to the nearest integer) in days is _____.

Q.No.
53

A car company manufactures 200 units of a component per day. The component is installed in different car models at a rate of 15000 units per year. The company operates its production facility 300 days per year to manufacture the component. The setup cost for each production run is Rs. 200 and the inventory holding cost per year is Rs. 2 per unit. The Economic Production Quantity (EPQ) is _____.

Q.No.
54

A company has to perform five tasks (P, Q, R, S and T) to make an assembly. Task times and immediate predecessors of the tasks are listed below. If an assembly line is designed to obtain the maximum output rate, the efficiency of the line in % is _____.

Task	Task time (Seconds)	Immediate predecessor(s)
P	20	-
Q	25	P
R	10	Q
S	15	Q
T	25	R, S

Q.No.
55

In a work study experiment, it is observed that a worker completes a job in an average time of 15 minutes with a performance rating of 120%. The time required for another worker having a performance rating of 80% to complete the same job (rounded off to one decimal place) in minutes is _____.