

National Testing Agency

Question Paper Name :	B Tech 26 Aug 2021 Shift 1
Subject Name :	B TECH
Creation Date :	2021-08-26 17:34:07
Duration :	180
Total Marks :	300
Display Marks:	Yes

B TECH

Group Number :	1
Group Id :	864351244
Group Maximum Duration :	0
Group Minimum Duration :	180
Show Attended Group? :	No
Edit Attended Group? :	No
Break time :	0
Group Marks :	300
Is this Group for Examiner? :	No

Physics Section A

Section Id :	864351902
Section Number :	1
Section type :	Online
Mandatory or Optional :	Mandatory
Number of Questions :	20
Number of Questions to be attempted :	20
Section Marks :	80

Enable Mark as Answered Mark for Review and Clear Response : Yes
Sub-Section Number : 1
Sub-Section Id : 8643511129
Question Shuffling Allowed : Yes

Question Number : 1 Question Id : 86435119990 Question Type : MCQ Option Shuffling : Yes Is Question Mandatory : No
Correct Marks : 4 Wrong Marks : 1

In a Screw Gauge, fifth division of the circular scale coincides with the reference line when the ratchet is closed. There are 50 divisions on the circular scale, and the main scale moves by 0.5 mm on a complete rotation. For a particular observation the reading on the main scale is 5 mm and the 20th division of the circular scale coincides with reference line. Calculate the true reading.

Options :

86435166551. 5.20 mm

86435166552. 5.25 mm

86435166553. 5.15 mm

86435166554. 5.00 mm

Question Number : 2 Question Id : 86435119991 Question Type : MCQ Option Shuffling : Yes Is Question Mandatory : No
Correct Marks : 4 Wrong Marks : 1

The rms speeds of the molecules of Hydrogen, Oxygen and Carbondioxide at the same temperature are V_H , V_O and V_C respectively then :

Options :

86435166555. $V_H = V_O = V_C$

86435166556. $V_H = V_O > V_C$

86435166557. $V_H > V_O > V_C$

86435166558. $V_C > V_O > V_H$

Question Number : 3 Question Id : 86435119992 Question Type : MCQ Option Shuffling : Yes Is Question Mandatory : No Correct Marks : 4 Wrong Marks : 1

Identify the logic operation carried out by the given circuit :

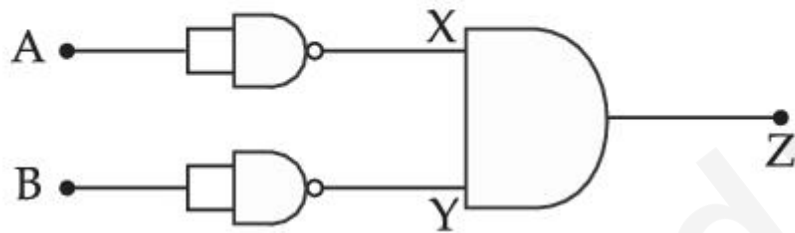

Options :

86435166559. AND

86435166560. OR

86435166561. NAND

86435166562. NOR

Question Number : 4 Question Id : 86435119993 Question Type : MCQ Option Shuffling : Yes Is Question Mandatory : No

Correct Marks : 4 Wrong Marks : 1

An electric appliance supplies 6000 J/min heat to the system. If the system delivers a power of 90 W. How long it would take to increase the internal energy by 2.5×10^3 J ?

Options :

86435166563. 2.5×10^1 s

86435166564. 2.5×10^2 s

86435166565. 2.4×10^3 s

86435166566. 4.1×10^1 s

Question Number : 5 Question Id : 86435119994 Question Type : MCQ Option Shuffling : Yes Is Question Mandatory : No

Correct Marks : 4 Wrong Marks : 1

A particular hydrogen like ion emits radiation of frequency 2.92×10^{15} Hz when it makes transition from $n=3$ to $n=1$. The frequency in Hz of radiation emitted in transition from $n=2$ to $n=1$ will be :

Options :

86435166567. 4.38×10^{15}

86435166568. 6.57×10^{15}

86435166569. 0.44×10^{15}

86435166570. 2.46×10^{15}

Question Number : 6 Question Id : 86435119995 Question Type : MCQ Option Shuffling : Yes Is Question Mandatory : No
Correct Marks : 4 Wrong Marks : 1

Two narrow bores of diameter 5.0 mm and 8.0 mm are joined together to form a U-shaped tube open at both ends. If this U-tube contains water, what is the difference in the level of two limbs of the tube.

[Take surface tension of water $T = 7.3 \times 10^{-2} \text{ Nm}^{-1}$, angle of contact = 0, $g = 10 \text{ ms}^{-2}$ and density of water = $1.0 \times 10^3 \text{ kg m}^{-3}$]

Options :

86435166571. 5.34 mm

86435166572. 3.62 mm

86435166573. 4.97 mm

86435166574. 2.19 mm

Question Number : 7 Question Id : 86435119996 Question Type : MCQ Option Shuffling : Yes Is Question Mandatory : No
Correct Marks : 4 Wrong Marks : 1

In a photoelectric experiment ultraviolet light of wavelength 280 nm is used with lithium cathode having work function $\phi = 2.5 \text{ eV}$. If the wavelength of incident light is switched to 400 nm, find out the change in the stopping potential. ($h = 6.63 \times 10^{-34} \text{ Js}$, $c = 3 \times 10^8 \text{ ms}^{-1}$)

Options :

86435166575. 1.3 V

86435166576. 1.9 V

86435166577. 0.6 V

86435166578. 1.1 V

Question Number : 8 Question Id : 86435119997 Question Type : MCQ Option Shuffling : Yes Is Question Mandatory : No Correct Marks : 4 Wrong Marks : 1

Car B overtakes another car A at a relative speed of 40 ms^{-1} . How fast will the image of car B appear to move in the mirror of focal length 10 cm fitted in car A, when the car B is 1.9 m away from the car A ?

Options :

86435166579. 0.1 ms^{-1}

86435166580. 0.2 ms^{-1}

86435166581. 40 ms^{-1}

86435166582. 4 ms^{-1}

Question Number : 9 Question Id : 86435119998 Question Type : MCQ Option Shuffling : Yes Is Question Mandatory : No Correct Marks : 4 Wrong Marks : 1

An inductor coil stores 64 J of magnetic field energy and dissipates energy at the rate of 640 W when a current of 8 A is passed through it. If this coil is joined across an ideal battery, find the time constant of the circuit in seconds :

Options :

- 86435166583. 0.2
- 86435166584. 0.4
- 86435166585. 0.8
- 86435166586. 0.125

Question Number : 10 Question Id : 86435119999 Question Type : MCQ Option Shuffling : Yes Is Question Mandatory : No
Correct Marks : 4 Wrong Marks : 1

A series LCR circuit driven by 300 V at a frequency of 50 Hz contains a resistance $R = 3 \text{ k}\Omega$, an inductor of inductive reactance $X_L = 250\pi \Omega$ and an unknown capacitor. The value of capacitance to maximize the average power should be :

(take $\pi^2 = 10$)

Options :

- 86435166587. 400 μF
- 86435166588. 40 μF
- 86435166589. 25 μF

86435166590. $4 \mu\text{F}$

Question Number : 11 Question Id : 86435120000 Question Type : MCQ Option Shuffling : Yes Is Question Mandatory : No

Correct Marks : 4 Wrong Marks : 1

The fractional change in the magnetic field intensity at a distance 'r' from centre on the axis of current carrying coil of radius 'a' to the magnetic field intensity at the centre of the same coil is : (Take $r < a$).

Options :

86435166591. $\frac{3}{2} \frac{a^2}{r^2}$

86435166592. $\frac{2}{3} \frac{a^2}{r^2}$

86435166593. $\frac{2}{3} \frac{r^2}{a^2}$

86435166594. $\frac{3}{2} \frac{r^2}{a^2}$

Question Number : 12 Question Id : 86435120001 Question Type : MCQ Option Shuffling : Yes Is Question Mandatory : No

Correct Marks : 4 Wrong Marks : 1

In the given figure, the emf of the cell is 2.2 V and if internal resistance is 0.6Ω . Calculate the power dissipated in the whole circuit :

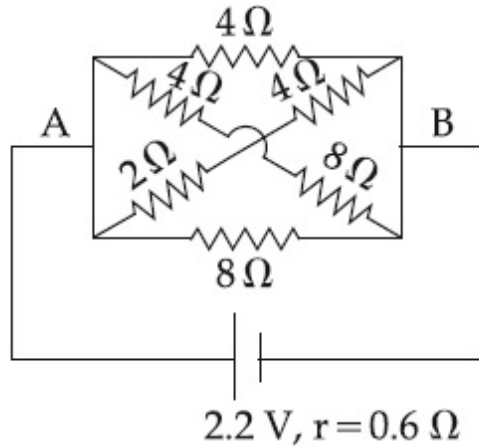

Options :

- 86435166595. 2.2 W
- 86435166596. 4.4 W
- 86435166597. 0.65 W
- 86435166598. 1.32 W

Question Number : 13 Question Id : 86435120002 Question Type : MCQ Option Shuffling : Yes Is Question Mandatory : No Correct Marks : 4 Wrong Marks : 1

A solid metal sphere of radius R having charge q is enclosed inside the concentric spherical shell of inner radius a and outer radius b as shown in figure. The approximate variation electric field \vec{E} as a function of distance r from centre O is given by :

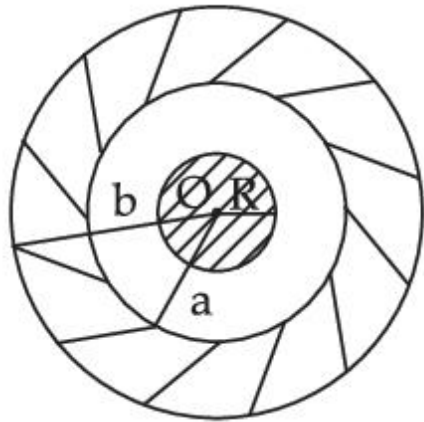

Options :

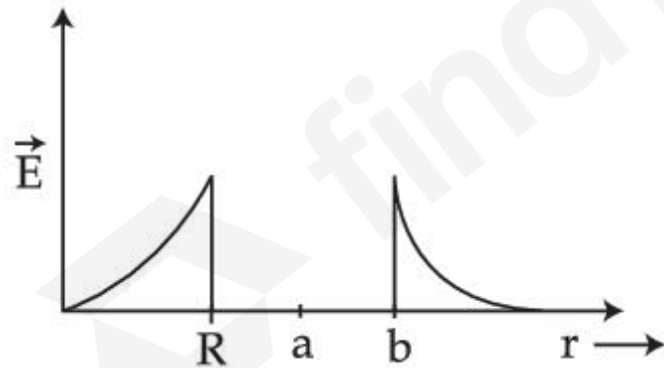

86435166599.

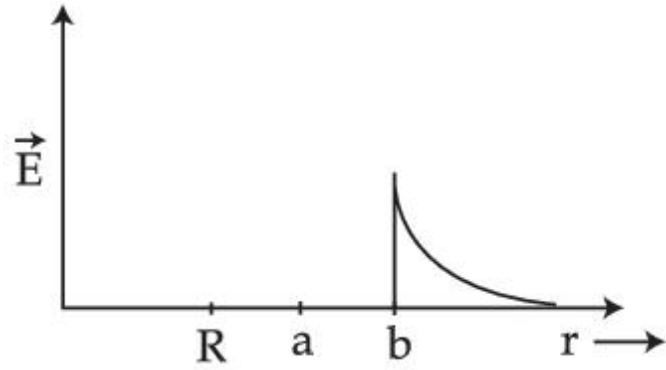

86435166600.

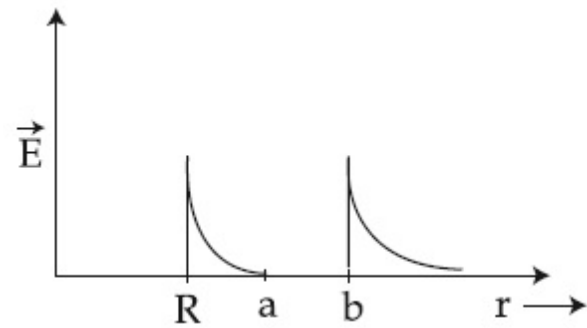

86435166601.

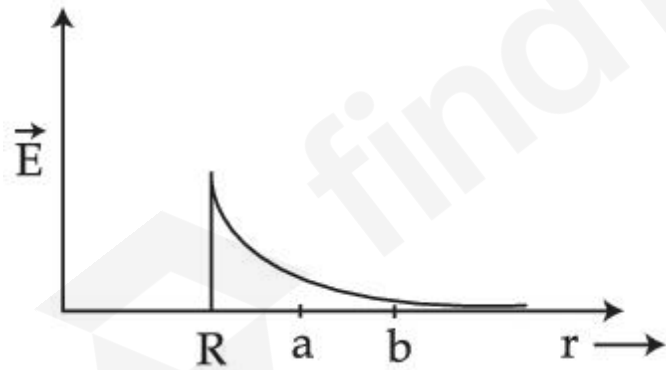

86435166602.

Question Number : 14 Question Id : 86435120003 Question Type : MCQ Option Shuffling : Yes Is Question Mandatory : No Correct Marks : 4 Wrong Marks : 1

The material filled between the plates of a parallel plate capacitor has resistivity $200 \Omega\text{m}$. The value of capacitance of the capacitor is 2 pF . If a potential difference of 40 V is applied across the plates of the capacitor, then the value of leakage current flowing out of the capacitor is : (given the value of relative permittivity of material is 50)

Options :

86435166603. 9.0 mA

86435166604. 0.9 mA

86435166605. $0.9 \mu\text{A}$

86435166606. $9.0 \mu\text{A}$

Question Number : 15 Question Id : 86435120004 Question Type : MCQ Option Shuffling : Yes Is Question Mandatory : No
Correct Marks : 4 Wrong Marks : 1

Inside a uniform spherical shell :

- (a) the gravitational field is zero.
- (b) the gravitational potential is zero.
- (c) the gravitational field is same everywhere.
- (d) the gravitation potential is same everywhere.
- (e) all of the above

Choose the **most appropriate** answer from the options given below :

Options :

86435166607. (b), (c) and (d) only

86435166608. (a), (b) and (c) only

86435166609. (a), (c) and (d) only

86435166610. (e) only

Question Number : 16 Question Id : 86435120005 Question Type : MCQ Option Shuffling : Yes Is Question Mandatory : No

Correct Marks : 4 Wrong Marks : 1

The initial mass of a rocket is 1000 kg. Calculate at what rate the fuel should be burnt so that the rocket is given an acceleration of 20 ms^{-2} . The gases come out at a relative speed of 500 ms^{-1} with respect to the rocket :

[Use $g = 10 \text{ m/s}^2$]

Options :

86435166611. 60 kg s^{-1}

86435166612. $6.0 \times 10^2 \text{ kg s}^{-1}$

86435166613. 500 kg s^{-1}

86435166614. 10 kg s^{-1}

Question Number : 17 Question Id : 86435120006 Question Type : MCQ Option Shuffling : Yes Is Question Mandatory : No

Correct Marks : 4 Wrong Marks : 1

What equal length of an iron wire and a copper-nickel alloy wire, each of 2 mm diameter connected parallel to give an equivalent resistance of 3Ω ?

(Given resistivities of iron and copper-nickel alloy wire are $12 \mu\Omega \text{ cm}$ and $51 \mu\Omega \text{ cm}$ respectively)

Options :

86435166615. 110 m

86435166616. 97 m

86435166617. 90 m

86435166618. 82 m

Question Number : 18 Question Id : 86435120007 Question Type : MCQ Option Shuffling : Yes Is Question Mandatory : No

Correct Marks : 4 Wrong Marks : 1

The magnitude of vectors \vec{OA} , \vec{OB} and \vec{OC} in the given figure are equal. The direction of $\vec{OA} + \vec{OB} - \vec{OC}$ with x -axis will be :

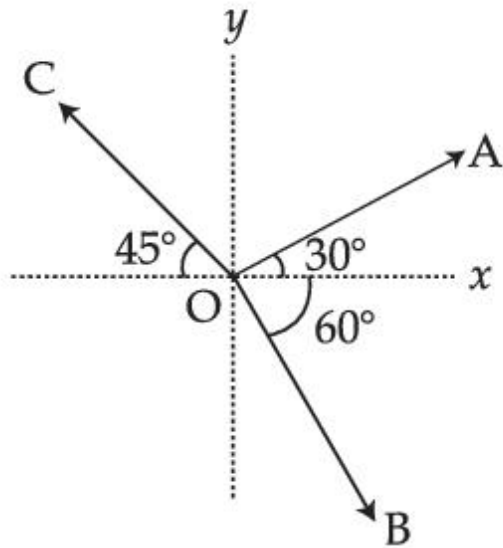

Options :

86435166619. $\tan^{-1} \frac{(1 - \sqrt{3} - \sqrt{2})}{(1 + \sqrt{3} + \sqrt{2})}$

86435166620. $\tan^{-1} \frac{(\sqrt{3} - 1 + \sqrt{2})}{(1 + \sqrt{3} - \sqrt{2})}$

86435166621. $\tan^{-1} \frac{(1 + \sqrt{3} - \sqrt{2})}{(1 - \sqrt{3} - \sqrt{2})}$

86435166622. $\tan^{-1} \frac{(\sqrt{3} - 1 + \sqrt{2})}{(1 - \sqrt{3} + \sqrt{2})}$

Question Number : 19 Question Id : 86435120008 Question Type : MCQ Option Shuffling : Yes Is Question Mandatory : No
Correct Marks : 4 Wrong Marks : 1

Statement I :

By doping silicon semiconductor with pentavalent material, the electrons density increases.

Statement II :

The n-type semiconductor has net negative charge.

In the light of the above statements, choose the **most appropriate** answer from the options given below :

Options :

86435166623. Both **Statement I** and **Statement II** are true.

86435166624. Both **Statement I** and **Statement II** are false.

86435166625. **Statement I** is true but **Statement II** is false.

86435166626. **Statement I** is false but **Statement II** is true.

Question Number : 20 Question Id : 86435120009 Question Type : MCQ Option Shuffling : Yes Is Question Mandatory : No
Correct Marks : 4 Wrong Marks : 1

If E, L, M and G denote the quantities as energy, angular momentum, mass and constant of gravitation respectively, then the dimensions of P in the formula $P = EL^2M^{-5}G^{-2}$ are :

Options :

86435166627. $[M^1 L^1 T^{-2}]$

86435166628. $[M^{-1} L^{-1} T^2]$

86435166629. $[M^0 L^1 T^0]$

86435166630. $[M^0 L^0 T^0]$

Physics Section B

Section Id :	864351903
Section Number :	2
Section type :	Online
Mandatory or Optional :	Mandatory
Number of Questions :	10
Number of Questions to be attempted :	5
Section Marks :	20
Enable Mark as Answered Mark for Review and Clear Response :	Yes
Sub-Section Number :	1
Sub-Section Id :	8643511130
Question Shuffling Allowed :	Yes

Question Number : 21 Question Id : 86435120010 Question Type : SA
Correct Marks : 4 Wrong Marks : 0

A uniform chain of length 3 meter and mass 3 kg overhangs a smooth table with 2 meter laying on the table. If k is the kinetic energy of the chain in joule as it completely slips off the table, then the value of k is _____.

(Take $g = 10 \text{ m/s}^2$)

Response Type : Numeric

Evaluation Required For SA : Yes

Show Word Count : Yes

Answers Type : Equal

Text Areas : PlainText

Possible Answers :

1

Question Number : 22 **Question Id :** 86435120011 **Question Type :** SA

Correct Marks : 4 **Wrong Marks :** 0

Consider a badminton racket with length scales as shown in the figure.

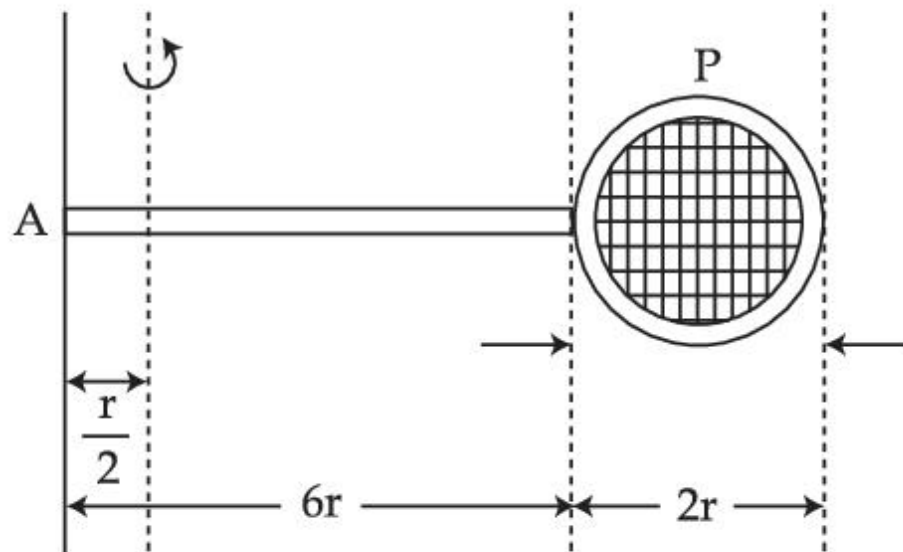

If the mass of the linear and circular portions of the badminton racket are same (M) and the mass of the threads are negligible, the moment of inertia of the racket about an axis perpendicular to the handle and in the plane of the ring at, $\frac{r}{2}$ distance from the end A of the

handle will be _____ Mr^2 .

Response Type : Numeric

Evaluation Required For SA : Yes

Show Word Count : Yes

Answers Type : Equal

Text Areas : PlainText

Possible Answers :

1

Correct Marks : 4 Wrong Marks : 0

A soap bubble of radius 3 cm is formed inside the another soap bubble of radius 6 cm. The radius of an equivalent soap bubble which has the same excess pressure as inside the smaller bubble with respect to the atmospheric pressure is _____ cm.

Response Type : Numeric

Evaluation Required For SA : Yes

Show Word Count : Yes

Answers Type : Equal

Text Areas : PlainText

Possible Answers :

1

Question Number : 24 Question Id : 86435120013 Question Type : SA

Correct Marks : 4 Wrong Marks : 0

Two travelling waves produces a standing wave represented by equation.

$y = 1.0 \text{ mm} \cos(1.57 \text{ cm}^{-1}) x \sin(78.5 \text{ s}^{-1})t$. The node closest to the origin in the region $x > 0$ will be at $x =$ _____ cm.

Response Type : Numeric

Evaluation Required For SA : Yes

Show Word Count : Yes

Answers Type : Equal

Text Areas : PlainText

Possible Answers :

1

Question Number : 25 Question Id : 86435120014 Question Type : SA

Correct Marks : 4 Wrong Marks : 0

Two short magnetic dipoles m_1 and m_2 each having magnetic moment of 1 Am^2 are placed at point O and P respectively. The distance between OP is 1 meter. The torque experienced by the magnetic dipole m_2 due to the presence of m_1 is _____ $\times 10^{-7} \text{ Nm}$.

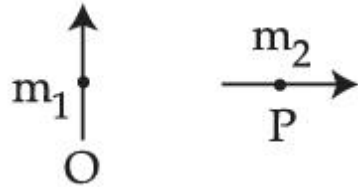

Response Type : Numeric

Evaluation Required For SA : Yes

Show Word Count : Yes

Answers Type : Equal

Text Areas : PlainText

Possible Answers :

1

Question Number : 26 **Question Id :** 86435120015 **Question Type :** SA

Correct Marks : 4 **Wrong Marks :** 0

The electric field in a plane electromagnetic wave is given by

$$\vec{E} = 200 \cos \left[\left(\frac{0.5 \times 10^3}{\text{m}} \right) x - \left(1.5 \times 10^{11} \frac{\text{rad}}{\text{s}} \times t \right) \right] \frac{\text{V}}{\text{m}} \hat{j}$$

If this wave falls normally on a perfectly reflecting surface having an area of 100 cm^2 . If the radiation pressure exerted by the E.M. wave on the surface during a 10 minute exposure is

$$\frac{x}{10^9} \frac{\text{N}}{\text{m}^2}. \text{ Find the value of } x.$$

Response Type : Numeric

Evaluation Required For SA : Yes

Show Word Count : Yes

Answers Type : Equal

Text Areas : PlainText

Possible Answers :

1

Question Number : 27 **Question Id :** 86435120016 **Question Type :** SA

Correct Marks : 4 **Wrong Marks :** 0

White light is passed through a double slit and interference is observed on a screen 1.5 m away. The separation between the slits is 0.3 mm. The first violet and red fringes are formed 2.0 mm and 3.5 mm away from the central white fringes. The difference in wavelengths of red and violet light is _____ nm.

Response Type : Numeric

Evaluation Required For SA : Yes

Show Word Count : Yes

Answers Type : Equal

Text Areas : PlainText

Possible Answers :

1

Question Number : 28 Question Id : 86435120017 Question Type : SA

Correct Marks : 4 Wrong Marks : 0

An amplitude modulated wave is represented by

$C_m(t) = 10(1 + 0.2 \cos 12560t) \sin (111 \times 10^4 t)$ volts. The modulating frequency in kHz will be _____.

Response Type : Numeric

Evaluation Required For SA : Yes

Show Word Count : Yes

Answers Type : Equal

Text Areas : PlainText

Possible Answers :

1

Question Number : 29 Question Id : 86435120018 Question Type : SA

Correct Marks : 4 Wrong Marks : 0

Two spherical balls having equal masses with radius of 5 cm each are thrown upwards along the same vertical direction at an interval of 3 s with the same initial velocity of 35 m/s, then these balls collide at a height of _____ m.

(take $g = 10 \text{ m/s}^2$)

Response Type : Numeric

Evaluation Required For SA : Yes

Show Word Count : Yes

Answers Type : Equal

Text Areas : PlainText

Possible Answers :

1

Question Number : 30 Question Id : 86435120019 Question Type : SA

Correct Marks : 4 Wrong Marks : 0

A source and a detector move away from each other in absence of wind with a speed of 20 m/s with respect to the ground. If the detector detects a frequency of 1800 Hz of the sound coming from the source, then the original frequency of source considering speed of sound in air 340 m/s will be _____ Hz.

Response Type : Numeric

Evaluation Required For SA : Yes

Show Word Count : Yes

Answers Type : Equal

Text Areas : PlainText

Possible Answers :

1

Chemistry Section A

Section Id :	864351904
Section Number :	3
Section type :	Online
Mandatory or Optional :	Mandatory
Number of Questions :	20
Number of Questions to be attempted :	20
Section Marks :	80
Enable Mark as Answered Mark for Review and Clear Response :	Yes
Sub-Section Number :	1
Sub-Section Id :	8643511131
Question Shuffling Allowed :	Yes

Question Number : 31 Question Id : 86435120020 Question Type : MCQ Option Shuffling : Yes Is Question Mandatory : No

Correct Marks : 4 Wrong Marks : 1

Given below are two statements :

Statement I : Frenkel defects are vacancy as well as interstitial defects.

Statement II : Frenkel defect leads to colour in ionic solids due to presence of F-centres.

Choose the **most appropriate** answer for the statements from the options given below :

Options :

86435166641. Both **Statement I** and **Statement II** are true

86435166642. Both **Statement I** and **Statement II** are false

86435166643. **Statement I** is true but **Statement II** is false

86435166644. **Statement I** is false but **Statement II** is true

Question Number : 32 Question Id : 86435120021 Question Type : MCQ Option Shuffling : Yes Is Question Mandatory : No

Correct Marks : 4 Wrong Marks : 1

Given below are two statements :

Statement I : According to Bohr's model of an atom, qualitatively the magnitude of velocity of electron increases with decrease in positive charges on the nucleus as there is no strong hold on the electron by the nucleus.

Statement II : According to Bohr's model of an atom, qualitatively the magnitude of velocity of electron increases with decrease in principal quantum number.

In the light of the above statements, choose the **most appropriate** answer from the options given below :

Options :

86435166645. Both **Statement I** and **Statement II** are true

86435166646. Both **Statement I** and **Statement II** are false

86435166647. **Statement I** is true but **Statement II** is false

86435166648. **Statement I** is false but **Statement II** is true

Question Number : 33 Question Id : 86435120022 Question Type : MCQ Option Shuffling : Yes Is Question Mandatory : No

Correct Marks : 4 Wrong Marks : 1

Given below are two statements :

Statement I : The limiting molar conductivity of KCl (strong electrolyte) is higher compared to that of CH_3COOH (weak electrolyte).

Statement II : Molar conductivity decreases with decrease in concentration of electrolyte.

In the light of the above statements, choose the **most appropriate** answer from the options given below :

Options :

86435166649. Both **Statement I** and **Statement II** are true

86435166650. Both **Statement I** and **Statement II** are false

86435166651. **Statement I** is true but **Statement II** is false

86435166652. **Statement I** is false but **Statement II** is true

Question Number : 34 Question Id : 86435120023 Question Type : MCQ Option Shuffling : Yes Is Question Mandatory : No
Correct Marks : 4 Wrong Marks : 1

Which one of the following is correct for the adsorption of a gas at a given temperature on a solid surface ?

Options :

86435166653. $\Delta H > 0, \Delta S > 0$

86435166654. $\Delta H < 0, \Delta S > 0$

86435166655. $\Delta H > 0, \Delta S < 0$

86435166656. $\Delta H < 0, \Delta S < 0$

Question Number : 35 Question Id : 86435120024 Question Type : MCQ Option Shuffling : Yes Is Question Mandatory : No
Correct Marks : 4 Wrong Marks : 1

Given below are two statements.

Statement I : The choice of reducing agents for metals extraction can be made by using Ellingham diagram, a plot of ΔG vs temperature.

Statement II : The value of ΔS increases from left to right in Ellingham diagram.

In the light of the above statements, choose the **most appropriate** answer from the options given below :

Options :

86435166657. Both **Statement I** and **Statement II** are true

86435166658. Both **Statement I** and **Statement II** are false

86435166659. **Statement I** is true but **Statement II** is false

86435166660. **Statement I** is false but **Statement II** is true

Question Number : 36 Question Id : 86435120025 Question Type : MCQ Option Shuffling : Yes Is Question Mandatory : No Correct Marks : 4 Wrong Marks : 1

Which one of the following methods is most suitable for preparing deionized water ?

Options :

86435166661. Clark's method

86435166662. Synthetic resin method

86435166663. Calgon's method

86435166664. Permutit method

Question Number : 37 Question Id : 86435120026 Question Type : MCQ Option Shuffling : Yes Is Question Mandatory : No Correct Marks : 4 Wrong Marks : 1

What are the products formed in sequence when excess of CO_2 is passed in slaked lime ?

Options :

86435166665. $\text{CaCO}_3, \text{Ca}(\text{HCO}_3)_2$

86435166666. $\text{Ca}(\text{HCO}_3)_2, \text{CaCO}_3$

86435166667. $\text{CaO}, \text{CaCO}_3$

86435166668. $\text{CaO}, \text{Ca}(\text{HCO}_3)_2$

Question Number : 38 Question Id : 86435120027 Question Type : MCQ Option Shuffling : Yes Is Question Mandatory : No Correct Marks : 4 Wrong Marks : 1

The **incorrect** statement is :

Options :

86435166669. Cl_2 is more reactive than ClF .

86435166670. F_2 is more reactive than ClF .

86435166671. On hydrolysis ClF forms HOCl and HF .

86435166672. F_2 is a stronger oxidizing agent than Cl_2 in aqueous solution.

Question Number : 39 Question Id : 86435120028 Question Type : MCQ Option Shuffling : Yes Is Question Mandatory : No Correct Marks : 4 Wrong Marks : 1

Which one of the following when dissolved in water gives coloured solution in nitrogen atmosphere ?

Options :

86435166673. ZnCl_2

86435166674. CuCl_2

86435166675. Cu_2Cl_2

86435166676. AgCl

Question Number : 40 Question Id : 86435120029 Question Type : MCQ Option Shuffling : Yes Is Question Mandatory : No Correct Marks : 4 Wrong Marks : 1

The conversion of hydroxyapatite occurs due to presence of F^- ions in water. The correct formula of hydroxyapatite is :

Options :

86435166677. $[3\text{Ca}_3(\text{PO}_4)_2 \cdot \text{CaF}_2]$

86435166678. $[\text{Ca}_3(\text{PO}_4)_2 \cdot \text{CaF}_2]$

86435166679. $[3\text{Ca}_3(\text{PO}_4)_2 \cdot \text{Ca}(\text{OH})_2]$

86435166680. $[3\text{Ca}(\text{OH})_2 \cdot \text{CaF}_2]$

Question Number : 41 Question Id : 86435120030 Question Type : MCQ Option Shuffling : Yes Is Question Mandatory : No Correct Marks : 4 Wrong Marks : 1

Which one of the following complexes is violet in colour ?

Options :

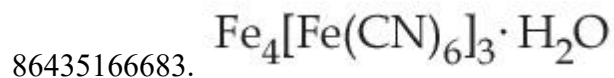
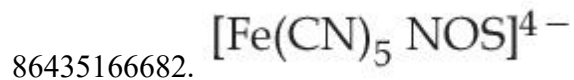
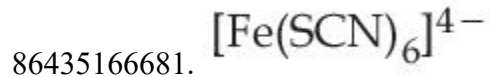

Question Number : 42 Question Id : 86435120031 Question Type : MCQ Option Shuffling : Yes Is Question Mandatory : No
 Correct Marks : 4 Wrong Marks : 1

Excess of isobutane on reaction with Br_2 in presence of light at 125°C gives which one of the following, as the major product ?

Options :

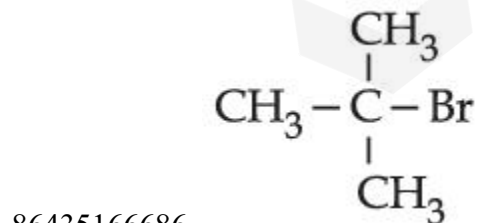
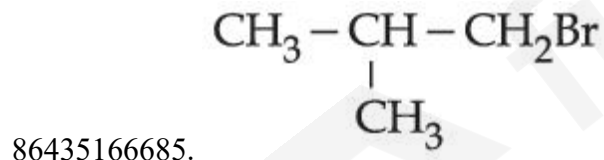

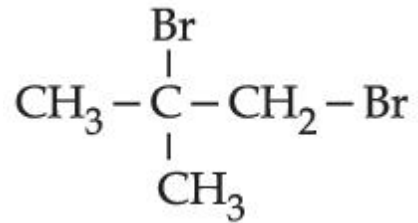

86435166687.

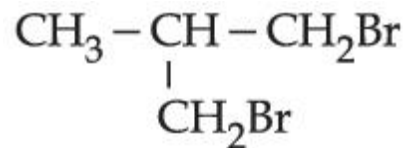

86435166688.

Question Number : 43 Question Id : 86435120032 Question Type : MCQ Option Shuffling : Yes Is Question Mandatory : No Correct Marks : 4 Wrong Marks : 1

The major product formed in the following reaction is :

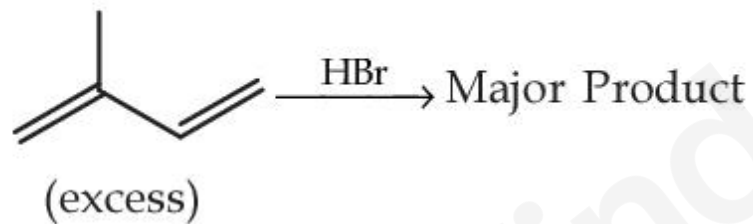

Options :

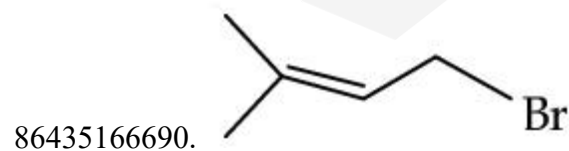
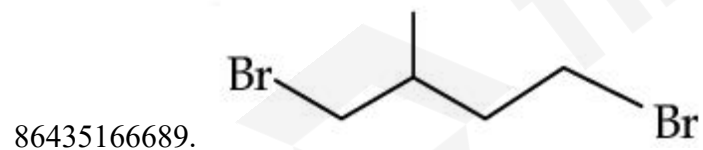

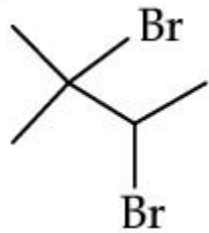

86435166691.

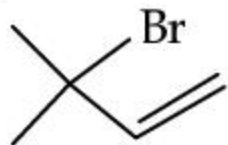

86435166692.

Question Number : 44 Question Id : 86435120033 Question Type : MCQ Option Shuffling : Yes Is Question Mandatory : No Correct Marks : 4 Wrong Marks : 1

Among the following compounds I-IV, which one forms a yellow precipitate on reacting sequentially with (i) NaOH (ii) dil. HNO_3 (iii) AgNO_3 ?

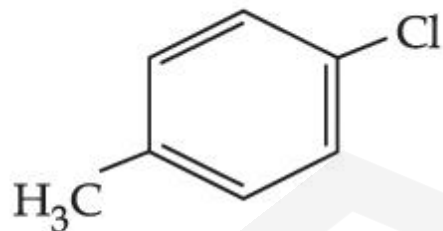

I

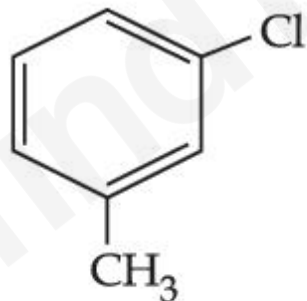

II

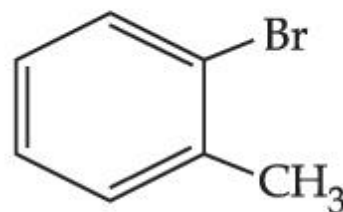

III

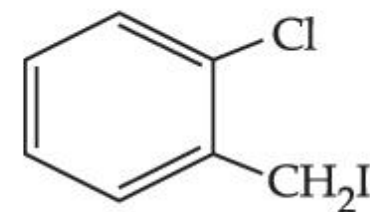

IV

Options :

86435166693. I

86435166694. II

86435166695. III

86435166696. IV

Question Number : 45 Question Id : 86435120034 Question Type : MCQ Option Shuffling : Yes Is Question Mandatory : No
 Correct Marks : 4 Wrong Marks : 1

The major products formed in the following reaction sequence **A** and **B** are :

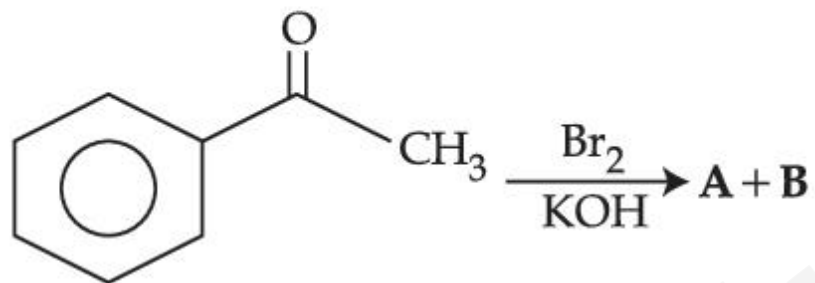

Options :

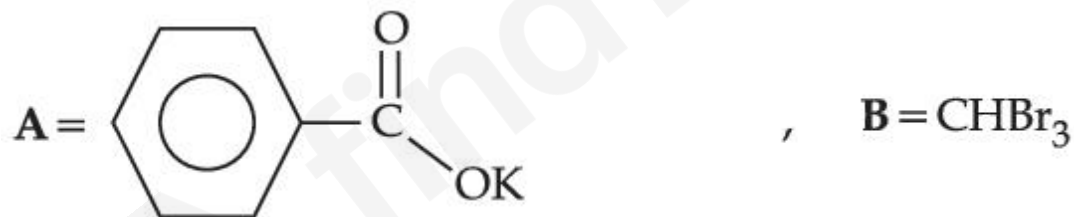

86435166697.

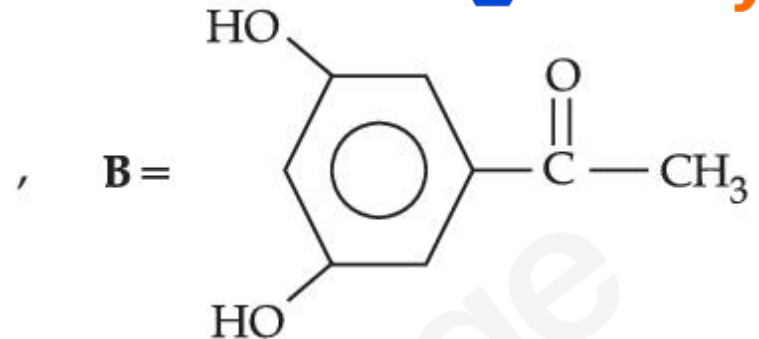
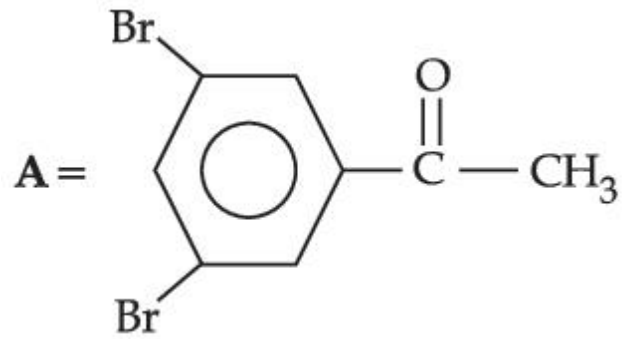

86435166698.

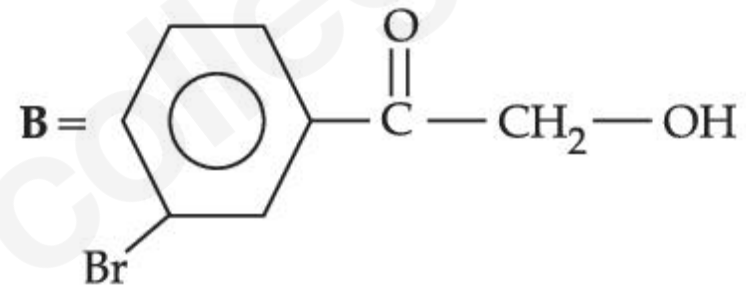
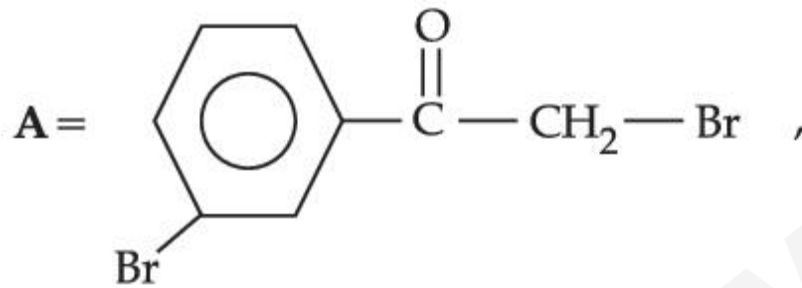

86435166699.

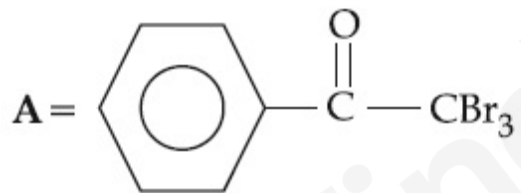

86435166700.

Question Number : 46 Question Id : 86435120035 Question Type : MCQ Option Shuffling : Yes Is Question Mandatory : No Correct Marks : 4 Wrong Marks : 1

The correct options for the products A and B of the following reactions are :

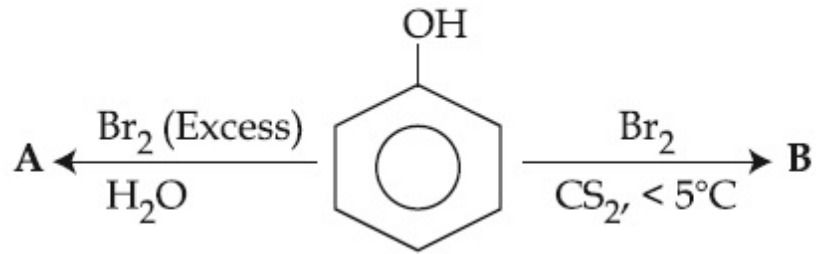

Options :

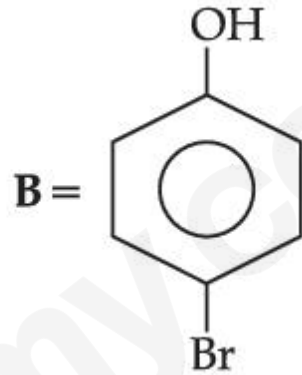
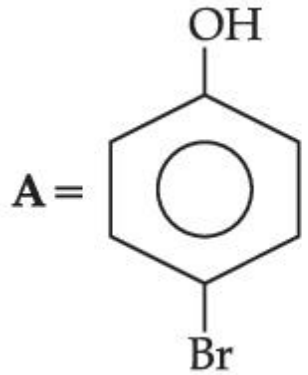

86435166701.

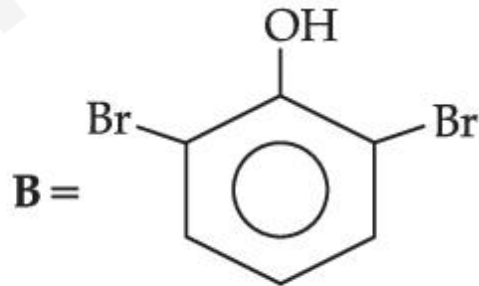
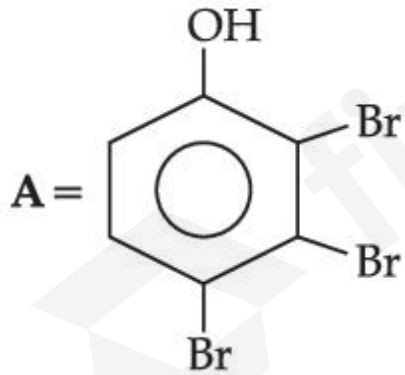

86435166702.

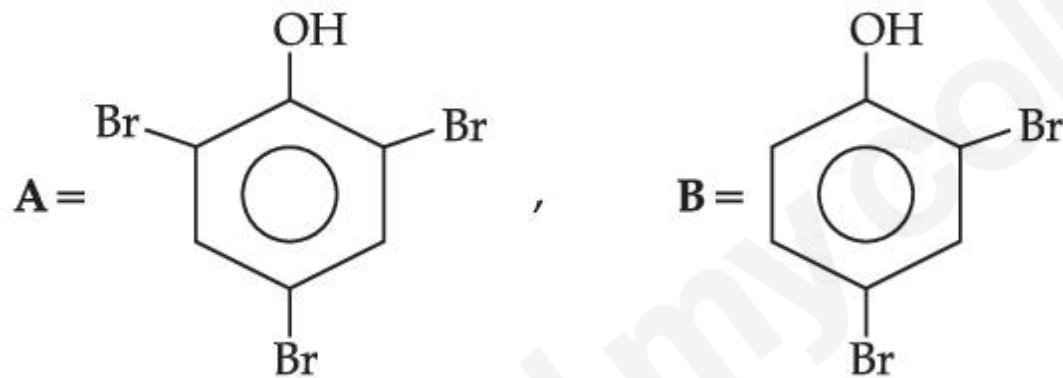
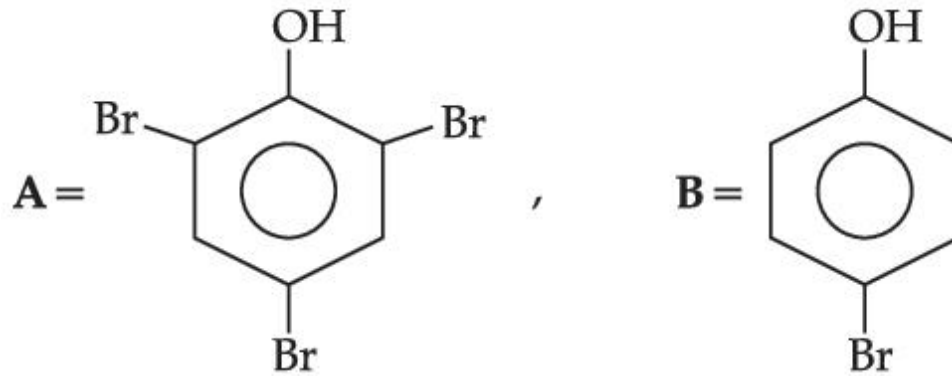

Question Number : 47 Question Id : 86435120036 Question Type : MCQ Option Shuffling : Yes Is Question Mandatory : No
 Correct Marks : 4 Wrong Marks : 1

The major product formed in the following reaction is :

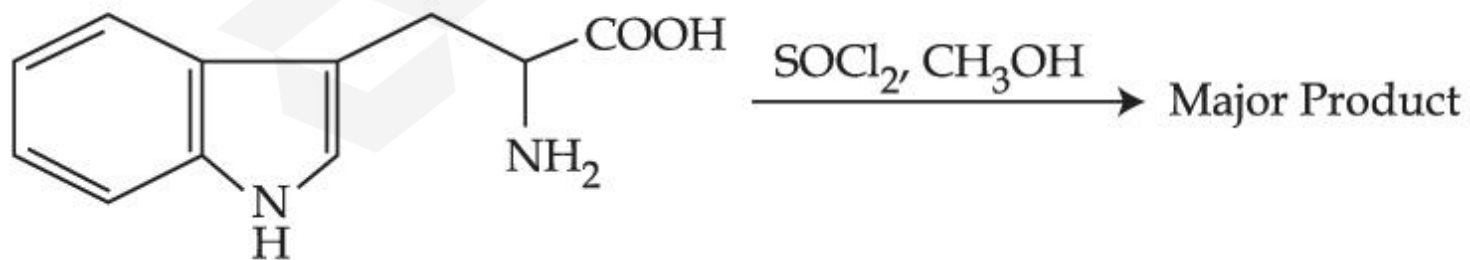

Options :

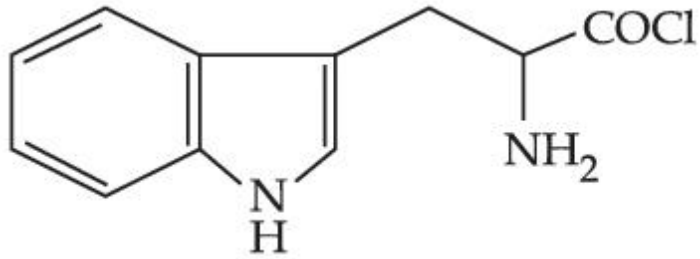

86435166705.

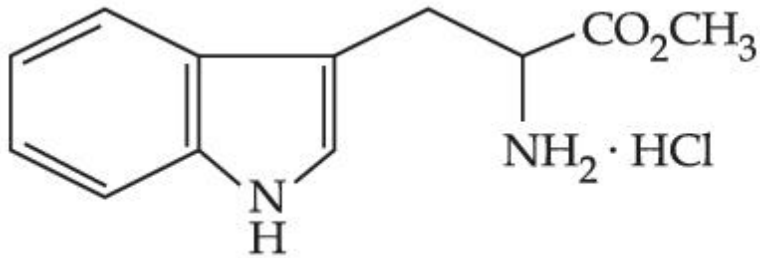

86435166706.

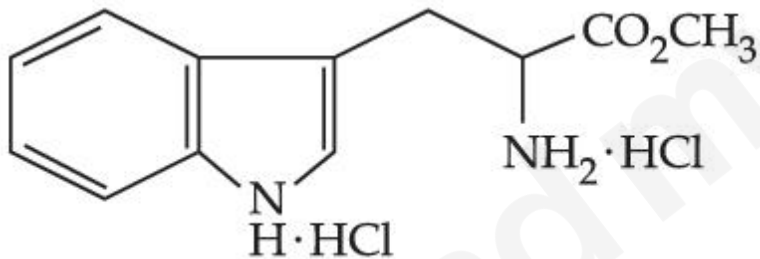

86435166707.

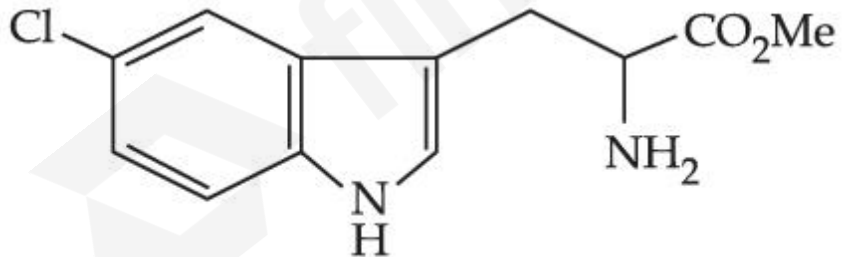

86435166708.

Question Number : 48 Question Id : 86435120037 Question Type : MCQ Option Shuffling : Yes Is Question Mandatory : No Correct Marks : 4 Wrong Marks : 1

The correct sequential addition of reagents in the preparation of 3-nitrobenzoic acid from benzene is :

Options :

86435166709. $\text{HNO}_3/\text{H}_2\text{SO}_4$, $\text{Br}_2/\text{AlBr}_3$, Mg/ether , CO_2 , H_3O^+

86435166710. $\text{Br}_2/\text{AlBr}_3$, NaCN , H_3O^+ , $\text{HNO}_3/\text{H}_2\text{SO}_4$

86435166711. $\text{Br}_2/\text{AlBr}_3$, $\text{HNO}_3/\text{H}_2\text{SO}_4$, NaCN , H_3O^+

86435166712. $\text{Br}_2/\text{AlBr}_3$, $\text{HNO}_3/\text{H}_2\text{SO}_4$, Mg/ether , CO_2 , H_3O^+

Question Number : 49 Question Id : 86435120038 Question Type : MCQ Option Shuffling : Yes Is Question Mandatory : No

Correct Marks : 4 Wrong Marks : 1

The polymer formed on heating Novolac with formaldehyde is :

Options :

86435166713. Melamine

86435166714. Bakelite

86435166715. Polyester

86435166716. Nylon 6,6

Question Number : 50 Question Id : 86435120039 Question Type : MCQ Option Shuffling : Yes Is Question Mandatory : No

Correct Marks : 4 Wrong Marks : 1

Given below are two statements :

Statement I : In the titration between strong acid and weak base methyl orange is suitable as an indicator.

Statement II : For titration of acetic acid with NaOH phenolphthalein is not a suitable indicator.

In the light of the above statements, choose the **most appropriate** answer from the options given below :

Options :

86435166717. Both **Statement I** and **Statement II** are true

86435166718. Both **Statement I** and **Statement II** are false

86435166719. **Statement I** is true but **Statement II** is false

86435166720. **Statement I** is false but **Statement II** is true

Chemistry Section B

Section Id :	864351905
Section Number :	4
Section type :	Online
Mandatory or Optional :	Mandatory
Number of Questions :	10
Number of Questions to be attempted :	5
Section Marks :	20

Enable Mark as Answered Mark for Review and Clear Response : Yes
Sub-Section Number : 1
Sub-Section Id : 8643511132
Question Shuffling Allowed : Yes

Question Number : 51 Question Id : 86435120040 Question Type : SA
Correct Marks : 4 Wrong Marks : 0

An aqueous KCl solution of density 1.20 g mL^{-1} has a molality of 3.30 mol kg^{-1} . The molarity of the solution in mol L^{-1} is _____. (Nearest integer)

[Molar mass of KCl = 74.5]

Response Type : Numeric
Evaluation Required For SA : Yes
Show Word Count : Yes
Answers Type : Equal
Text Areas : PlainText
Possible Answers :

1

Question Number : 52 Question Id : 86435120041 Question Type : SA
Correct Marks : 4 Wrong Marks : 0

AB_3 is an interhalogen T-shaped molecule. The number of lone pairs of electrons on A is _____. (Integer answer)

Response Type : Numeric
Evaluation Required For SA : Yes
Show Word Count : Yes
Answers Type : Equal
Text Areas : PlainText
Possible Answers :

1

Question Number : 53 Question Id : 86435120042 Question Type : SA

Correct Marks : 4 Wrong Marks : 0

The Born-Haber cycle for KCl is evaluated with the following data :

$$\Delta_f H^\ominus \text{ for KCl} = -436.7 \text{ kJ mol}^{-1}; \Delta_{\text{sub}} H^\ominus \text{ for K} = 89.2 \text{ kJ mol}^{-1};$$

$$\Delta_{\text{ionization}} H^\ominus \text{ for K} = 419.0 \text{ kJ mol}^{-1}; \Delta_{\text{electron gain}} H^\ominus \text{ for Cl}_{(g)} = -348.6 \text{ kJ mol}^{-1};$$

$$\Delta_{\text{bond}} H^\ominus \text{ for Cl}_2 = 243.0 \text{ kJ mol}^{-1}$$

The magnitude of lattice enthalpy of KCl in kJ mol^{-1} is _____. (Nearest integer)

Response Type : Numeric

Evaluation Required For SA : Yes

Show Word Count : Yes

Answers Type : Equal

Text Areas : PlainText

Possible Answers :

1

Question Number : 54 Question Id : 86435120043 Question Type : SA

Correct Marks : 4 Wrong Marks : 0

Of the following four aqueous solutions, total number of those solutions whose freezing point is lower than that of 0.10 M $\text{C}_2\text{H}_5\text{OH}$ is _____. (Integer answer)



Response Type : Numeric

Evaluation Required For SA : Yes

Show Word Count : Yes

Answers Type : Equal

Text Areas : PlainText

Possible Answers :

1

Question Number : 55 **Question Id :** 86435120044 **Question Type :** SA

Correct Marks : 4 **Wrong Marks :** 0

The OH^- concentration in a mixture of 5.0 mL of 0.0504 M NH_4Cl and 2 mL of 0.0210 M NH_3 solution is $x \times 10^{-6}$ M. The value of x is _____. (Nearest integer)

[Given $K_w = 1 \times 10^{-14}$ and $K_b = 1.8 \times 10^{-5}$]

Response Type : Numeric

Evaluation Required For SA : Yes

Show Word Count : Yes

Answers Type : Equal

Text Areas : PlainText

Possible Answers :

1

Question Number : 56 **Question Id :** 86435120045 **Question Type :** SA

Correct Marks : 4 **Wrong Marks :** 0

The following data was obtained for chemical reaction given below at 975 K.

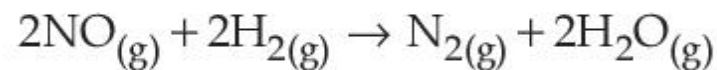

	[NO]	[H ₂]	Rate
	mol L ⁻¹	mol L ⁻¹	mol L ⁻¹ s ⁻¹
(A)	8×10^{-5}	8×10^{-5}	7×10^{-9}
(B)	24×10^{-5}	8×10^{-5}	2.1×10^{-8}
(C)	24×10^{-5}	32×10^{-5}	8.4×10^{-8}

The order of the reaction with respect to NO is _____. [Integer answer]

Response Type : Numeric

Evaluation Required For SA : Yes

Show Word Count : Yes

Answers Type : Equal

Text Areas : PlainText

Possible Answers :

1

Question Number : 57 **Question Id :** 86435120046 **Question Type :** SA

Correct Marks : 4 **Wrong Marks :** 0

These are physical properties of an element

- (A) Sublimation enthalpy
- (B) Ionisation enthalpy
- (C) Hydration enthalpy
- (D) Electron gain enthalpy

The total number of above properties that affect the reduction potential is _____.
(Integer answer)

Response Type : Numeric

Evaluation Required For SA : Yes

Show Word Count : Yes

Answers Type : Equal

Text Areas : PlainText

Possible Answers :

1

Question Number : 58 Question Id : 86435120047 Question Type : SA

Correct Marks : 4 Wrong Marks : 0

The number of $4f$ electrons in the ground state electronic configuration of Gd^{2+} is _____.

[Atomic number of Gd = 64]

Response Type : Numeric

Evaluation Required For SA : Yes

Show Word Count : Yes

Answers Type : Equal

Text Areas : PlainText

Possible Answers :

1

Question Number : 59 Question Id : 86435120048 Question Type : SA

Correct Marks : 4 Wrong Marks : 0

The ratio of number of water molecules in Mohr's salt and potash alum is _____ $\times 10^{-1}$.
(Integer answer)

Response Type : Numeric

Evaluation Required For SA : Yes

Show Word Count : Yes

Answers Type : Equal

Text Areas : PlainText

Possible Answers :

1

Question Number : 60 Question Id : 86435120049 Question Type : SA

Correct Marks : 4 Wrong Marks : 0

The total number of negative charge in the tetrapeptide, Gly-Glu-Asp-Tyr, at pH 12.5 will be _____.
(Integer answer)

Response Type : Numeric

Evaluation Required For SA : Yes

Show Word Count : Yes

Answers Type : Equal

Text Areas : PlainText

Possible Answers :

1

Mathematics Section A

Section Id :	864351906
Section Number :	5
Section type :	Online
Mandatory or Optional :	Mandatory
Number of Questions :	20

Number of Questions to be attempted :	20
Section Marks :	80
Enable Mark as Answered Mark for Review and Clear Response :	Yes
Sub-Section Number :	1
Sub-Section Id :	8643511133
Question Shuffling Allowed :	Yes

Question Number : 61 Question Id : 86435120050 Question Type : MCQ Option Shuffling : Yes Is Question Mandatory : No
Correct Marks : 4 Wrong Marks : 1

Out of all the patients in a hospital 89% are found to be suffering from heart ailment and 98% are suffering from lungs infection. If K% of them are suffering from both ailments, then K can **not** belong to the set :

Options :

86435166731. {84, 86, 88, 90}

86435166732. {80, 83, 86, 89}

86435166733. {79, 81, 83, 85}

86435166734. {84, 87, 90, 93}

Question Number : 62 Question Id : 86435120051 Question Type : MCQ Option Shuffling : Yes Is Question Mandatory : No
Correct Marks : 4 Wrong Marks : 1

The equation $\arg \left(\frac{z - 1}{z + 1} \right) = \frac{\pi}{4}$ represents a circle with :

Options :

86435166735. centre at $(0, 0)$ and radius $\sqrt{2}$

86435166736. centre at $(0, 1)$ and radius 2

86435166737. centre at $(0, 1)$ and radius $\sqrt{2}$

86435166738. centre at $(0, -1)$ and radius $\sqrt{2}$

Question Number : 63 Question Id : 86435120052 Question Type : MCQ Option Shuffling : Yes Is Question Mandatory : No Correct Marks : 4 Wrong Marks : 1

If $A = \begin{pmatrix} \frac{1}{\sqrt{5}} & \frac{2}{\sqrt{5}} \\ -2 & 1 \end{pmatrix}$, $B = \begin{pmatrix} 1 & 0 \\ i & 1 \end{pmatrix}$, $i = \sqrt{-1}$, and $Q = A^T B A$, then the inverse of the matrix

$A Q^{2021} A^T$ is equal to :

Options :

86435166739. $\begin{pmatrix} 1 & 0 \\ -2021 i & 1 \end{pmatrix}$

86435166740. $\begin{pmatrix} \frac{1}{\sqrt{5}} & -2021 \\ 2021 & \frac{1}{\sqrt{5}} \end{pmatrix}$

86435166741. $\begin{pmatrix} 1 & -2021 i \\ 0 & 1 \end{pmatrix}$

86435166742. $\begin{pmatrix} 1 & 0 \\ 2021 i & 1 \end{pmatrix}$

Question Number : 64 Question Id : 86435120053 Question Type : MCQ Option Shuffling : Yes Is Question Mandatory : No Correct Marks : 4 Wrong Marks : 1

Let $\theta \in \left(0, \frac{\pi}{2}\right)$. If the system of linear equations.

$$(1 + \cos^2\theta) x + \sin^2\theta y + 4 \sin 3\theta z = 0$$

$$\cos^2\theta x + (1 + \sin^2\theta) y + 4 \sin 3\theta z = 0$$

$$\cos^2\theta x + \sin^2\theta y + (1 + 4 \sin 3\theta)z = 0$$

has a non-trivial solution, then the value of θ is :

Options :

86435166743. $\frac{\pi}{18}$

86435166744. $\frac{7\pi}{18}$

86435166745. $\frac{5\pi}{18}$

86435166746. $\frac{4\pi}{9}$

Question Number : 65 Question Id : 86435120054 Question Type : MCQ Option Shuffling : Yes Is Question Mandatory : No Correct Marks : 4 Wrong Marks : 1

The sum of the series $\frac{1}{x+1} + \frac{2}{x^2+1} + \frac{2^2}{x^4+1} + \dots + \frac{2^{100}}{x^{2^{100}}+1}$ when $x=2$ is :

Options :

86435166747. $1 - \frac{2^{101}}{4^{101} - 1}$

86435166748. $1 - \frac{2^{100}}{4^{100} - 1}$

86435166749. $1 + \frac{2^{101}}{4^{101} - 1}$

86435166750. $1 + \frac{2^{100}}{4^{101} - 1}$

Question Number : 66 Question Id : 86435120055 Question Type : MCQ Option Shuffling : Yes Is Question Mandatory : No Correct Marks : 4 Wrong Marks : 1

If ${}^{20}C_r$ is the co-efficient of x^r in the expansion of $(1+x)^{20}$, then the value of $\sum_{r=0}^{20} r^2 {}^{20}C_r$ is equal to :

Options :

86435166751. 420×2^{19}

86435166752. 380×2^{19}

86435166753. 380×2^{18}

86435166754. 420×2^{18}

Question Number : 67 Question Id : 86435120056 Question Type : MCQ Option Shuffling : Yes Is Question Mandatory : No Correct Marks : 4 Wrong Marks : 1

If the sum of an infinite GP a, ar, ar^2, ar^3, \dots is 15 and the sum of the squares of its each term is 150, then the sum of ar^2, ar^4, ar^6, \dots is :

Options :

86435166755. $\frac{5}{2}$

86435166756. $\frac{1}{2}$

86435166757. $\frac{9}{2}$

86435166758. $\frac{25}{2}$

Question Number : 68 Question Id : 86435120057 Question Type : MCQ Option Shuffling : Yes Is Question Mandatory : No Correct Marks : 4 Wrong Marks : 1

Let $f(x) = \cos\left(2 \tan^{-1} \sin\left(\cot^{-1} \sqrt{\frac{1-x}{x}}\right)\right)$, $0 < x < 1$. Then :

Options :

86435166759. $(1-x)^2 f'(x) - 2(f(x))^2 = 0$

86435166760. $(1+x)^2 f'(x) + 2(f(x))^2 = 0$

86435166761. $(1-x)^2 f'(x) + 2(f(x))^2 = 0$

86435166762. $(1+x)^2 f'(x) - 2(f(x))^2 = 0$

Question Number : 69 Question Id : 86435120058 Question Type : MCQ Option Shuffling : Yes Is Question Mandatory : No Correct Marks : 4 Wrong Marks : 1

The value of $\int_{-1/\sqrt{2}}^{1/\sqrt{2}} \left(\left(\frac{x+1}{x-1} \right)^2 + \left(\frac{x-1}{x+1} \right)^2 - 2 \right)^{1/2} dx$ is :

Options :

86435166763. $4 \log_e (3 + 2\sqrt{2})$

86435166764. $\log_e 4$

86435166765. $\log_e 16$

86435166766. $2 \log_e 16$

Question Number : 70 Question Id : 86435120059 Question Type : MCQ Option Shuffling : Yes Is Question Mandatory : No Correct Marks : 4 Wrong Marks : 1

The value of $\lim_{n \rightarrow \infty} \frac{1}{n} \sum_{r=0}^{2n-1} \frac{n^2}{n^2 + 4r^2}$ is :

Options :

86435166767. $\frac{1}{4} \tan^{-1}(4)$

86435166768. $\frac{1}{2} \tan^{-1}(4)$

86435166769. $\tan^{-1}(4)$

86435166770. $\frac{1}{2} \tan^{-1}(2)$

Question Number : 71 Question Id : 86435120060 Question Type : MCQ Option Shuffling : Yes Is Question Mandatory : No Correct Marks : 4 Wrong Marks : 1

The sum of solutions of the equation $\frac{\cos x}{1 + \sin x} = |\tan 2x|$, $x \in \left(-\frac{\pi}{2}, \frac{\pi}{2}\right) - \left\{\frac{\pi}{4}, -\frac{\pi}{4}\right\}$ is :

Options :

86435166771. $\frac{\pi}{10}$

86435166772. $-\frac{11\pi}{30}$

86435166773. $-\frac{7\pi}{30}$

86435166774. $-\frac{\pi}{15}$

Question Number : 72 Question Id : 86435120061 Question Type : MCQ Option Shuffling : Yes Is Question Mandatory : No Correct Marks : 4 Wrong Marks : 1

Let ABC be a triangle with A $(-3, 1)$ and $\angle ACB = \theta, 0 < \theta < \frac{\pi}{2}$. If the equation of the median through B is $2x + y - 3 = 0$ and the equation of angle bisector of C is $7x - 4y - 1 = 0$, then $\tan\theta$ is equal to :

Options :

86435166775. $\frac{1}{2}$

86435166776. $\frac{3}{4}$

86435166777. $\frac{4}{3}$

86435166778. 2

Question Number : 73 Question Id : 86435120062 Question Type : MCQ Option Shuffling : Yes Is Question Mandatory : No

Correct Marks : 4 Wrong Marks : 1

If a line along a chord of the circle $4x^2 + 4y^2 + 120x + 675 = 0$, passes through the point $(-30, 0)$ and is tangent to the parabola $y^2 = 30x$, then the length of this chord is :

Options :

86435166779. 7

86435166780. $3\sqrt{5}$

86435166781. 5

86435166782. $5\sqrt{3}$

Question Number : 74 Question Id : 86435120063 Question Type : MCQ Option Shuffling : Yes Is Question Mandatory : No

Correct Marks : 4 Wrong Marks : 1

On the ellipse $\frac{x^2}{8} + \frac{y^2}{4} = 1$ let P be a point in the second quadrant such that the tangent at P to the ellipse is perpendicular to the line $x + 2y = 0$. Let S and S' be the foci of the ellipse and e be its eccentricity. If A is the area of the triangle SPS' then, the value of $(5 - e^2) \cdot A$ is :

Options :

86435166783. 24

86435166784. 14

86435166785. 12

86435166786. 6

Question Number : 75 Question Id : 86435120064 Question Type : MCQ Option Shuffling : Yes Is Question Mandatory : No Correct Marks : 4 Wrong Marks : 1

A plane P contains the line $x + 2y + 3z + 1 = 0 = x - y - z - 6$, and is perpendicular to the plane $-2x + y + z + 8 = 0$. Then which of the following points lies on P ?

Options :

86435166787. (2, -1, 1)

86435166788. (0, 1, 1)

86435166789. (1, 0, 1)

86435166790. (-1, 1, 2)

Question Number : 76 Question Id : 86435120065 Question Type : MCQ Option Shuffling : Yes Is Question Mandatory : No Correct Marks : 4 Wrong Marks : 1

Let $y = y(x)$ be a solution curve of the differential equation $(y + 1) \tan^2 x \, dx + \tan x \, dy + y \, dx = 0$, $x \in \left(0, \frac{\pi}{2}\right)$. If $\lim_{x \rightarrow 0^+} xy(x) = 1$, then the value of $y\left(\frac{\pi}{4}\right)$ is :

Options :

86435166791. $\frac{\pi}{4} - 1$

86435166792. $\frac{\pi}{4} + 1$

86435166793. $-\frac{\pi}{4}$

86435166794. $\frac{\pi}{4}$

Question Number : 77 Question Id : 86435120066 Question Type : MCQ Option Shuffling : Yes Is Question Mandatory : No
 Correct Marks : 4 Wrong Marks : 1

Let $\vec{a} = \hat{i} + \hat{j} + \hat{k}$ and $\vec{b} = \hat{j} - \hat{k}$. If \vec{c} is a vector such that $\vec{a} \times \vec{c} = \vec{b}$ and $\vec{a} \cdot \vec{c} = 3$,

then $\vec{a} \cdot (\vec{b} \times \vec{c})$ is equal to :

Options :

86435166795. -2

86435166796. 2

86435166797. -6

86435166798. 6

Question Number : 78 Question Id : 86435120067 Question Type : MCQ Option Shuffling : Yes Is Question Mandatory : No
Correct Marks : 4 Wrong Marks : 1

If the truth value of the Boolean expression $((p \vee q) \wedge (q \rightarrow r) \wedge (\sim r)) \rightarrow (p \wedge q)$ is false, then the truth values of the statements p, q, r respectively can be :

Options :

86435166799. T F T

86435166800. F F T

86435166801. F T F

86435166802. T F F

Question Number : 79 Question Id : 86435120068 Question Type : MCQ Option Shuffling : Yes Is Question Mandatory : No
Correct Marks : 4 Wrong Marks : 1

Let A and B be independent events such that $P(A) = p, P(B) = 2p$. The largest value of p , for which $P(\text{exactly one of } A, B \text{ occurs}) = \frac{5}{9}$, is :

Options :

86435166803. $\frac{1}{3}$

86435166804. $\frac{4}{9}$

86435166805. $\frac{5}{12}$

86435166806. $\frac{2}{9}$

Question Number : 80 Question Id : 86435120069 Question Type : MCQ Option Shuffling : Yes Is Question Mandatory : No Correct Marks : 4 Wrong Marks : 1

The mean and standard deviation of 20 observations were calculated as 10 and 2.5 respectively. It was found that by mistake one data value was taken as 25 instead of 35. If α and $\sqrt{\beta}$ are the mean and standard deviation respectively for correct data, then (α, β) is :

Options :

86435166807. (11, 25)

86435166808. (11, 26)

86435166809. (10.5, 26)

86435166810. (10.5, 25)

Mathematics Section B

Section Id :	864351907
Section Number :	6
Section type :	Online
Mandatory or Optional :	Mandatory
Number of Questions :	10
Number of Questions to be attempted :	5
Section Marks :	20
Enable Mark as Answered Mark for Review and Clear Response :	Yes
Sub-Section Number :	1
Sub-Section Id :	8643511134
Question Shuffling Allowed :	Yes

Question Number : 81 Question Id : 86435120070 Question Type : SA

Correct Marks : 4 Wrong Marks : 0

The number of three-digit even numbers, formed by the digits 0, 1, 3, 4, 6, 7 if the repetition of digits is not allowed, is _____.

Response Type : Numeric

Evaluation Required For SA : Yes

Show Word Count : Yes

Answers Type : Equal

Text Areas : PlainText

Possible Answers :

1

Question Number : 82 Question Id : 86435120071 Question Type : SA

Correct Marks : 4 Wrong Marks : 0

Let $a, b \in \mathbf{R}, b \neq 0$. Define a function

$$f(x) = \begin{cases} a \sin \frac{\pi}{2}(x - 1), & \text{for } x \leq 0 \\ \frac{\tan 2x - \sin 2x}{b x^3}, & \text{for } x > 0. \end{cases}$$

If f is continuous at $x=0$, then $10 - ab$ is equal to _____.

Response Type : Numeric

Evaluation Required For SA : Yes

Show Word Count : Yes

Answers Type : Equal

Text Areas : PlainText

Possible Answers :

1

Question Number : 83 **Question Id :** 86435120072 **Question Type :** SA

Correct Marks : 4 **Wrong Marks :** 0

The sum of all integral values of k ($k \neq 0$) for which the equation

$$\frac{2}{x-1} - \frac{1}{x-2} = \frac{2}{k} \text{ in } x \text{ has no real roots, is } \underline{\hspace{2cm}}.$$

Response Type : Numeric

Evaluation Required For SA : Yes

Show Word Count : Yes

Answers Type : Equal

Text Areas : PlainText

Possible Answers :

1

Question Number : 84 Question Id : 86435120073 Question Type : SA

Correct Marks : 4 Wrong Marks : 0

A wire of length 36 m is cut into two pieces, one of the pieces is bent to form a square and the other is bent to form a circle. If the sum of the areas of the two figures is minimum, and the circumference of the circle is k (meter), then $\left(\frac{4}{\pi} + 1\right)k$ is equal to _____.

Response Type : Numeric

Evaluation Required For SA : Yes

Show Word Count : Yes

Answers Type : Equal

Text Areas : PlainText

Possible Answers :

1

Question Number : 85 Question Id : 86435120074 Question Type : SA

Correct Marks : 4 Wrong Marks : 0

The area of the region $S = \{(x, y) : 3x^2 \leq 4y \leq 6x + 24\}$ is _____.

Response Type : Numeric

Evaluation Required For SA : Yes

Show Word Count : Yes

Answers Type : Equal

Text Areas : PlainText

Possible Answers :

1

Question Number : 86 Question Id : 86435120075 Question Type : SA

Correct Marks : 4 Wrong Marks : 0

If $y = y(x)$ is an implicit function of x such that $\log_e (x + y) = 4xy$, then $\frac{d^2y}{dx^2}$ at $x = 0$ is equal to

_____.

Response Type : Numeric

Evaluation Required For SA : Yes

Show Word Count : Yes

Answers Type : Equal

Text Areas : PlainText

Possible Answers :

1

Question Number : 87 **Question Id :** 86435120076 **Question Type :** SA

Correct Marks : 4 **Wrong Marks :** 0

If ${}^1P_1 + 2 \cdot {}^2P_2 + 3 \cdot {}^3P_3 + \dots + 15 \cdot {}^{15}P_{15} = {}^rP_r - s$, $0 \leq s \leq 1$, then ${}^{q+s}C_{r-s}$ is equal to

_____.

Response Type : Numeric

Evaluation Required For SA : Yes

Show Word Count : Yes

Answers Type : Equal

Text Areas : PlainText

Possible Answers :

1

Question Number : 88 **Question Id :** 86435120077 **Question Type :** SA

Correct Marks : 4 **Wrong Marks :** 0

Let the line L be the projection of the line

$$\frac{x - 1}{2} = \frac{y - 3}{1} = \frac{z - 4}{2}$$

in the plane $x - 2y - z = 3$. If d is the distance of the point (0, 0, 6) from L, then d^2 is equal to _____.

Response Type : Numeric

Evaluation Required For SA : Yes

Show Word Count : Yes

Answers Type : Equal

Text Areas : PlainText

Possible Answers :

1

Question Number : 89 **Question Id :** 86435120078 **Question Type :** SA

Correct Marks : 4 **Wrong Marks :** 0

Let $z = \frac{1 - i\sqrt{3}}{2}$, $i = \sqrt{-1}$. Then the value of

$$21 + \left(z + \frac{1}{z}\right)^3 + \left(z^2 + \frac{1}{z^2}\right)^3 + \left(z^3 + \frac{1}{z^3}\right)^3 + \dots + \left(z^{21} + \frac{1}{z^{21}}\right)^3$$

is _____.

Response Type : Numeric

Evaluation Required For SA : Yes

Show Word Count : Yes

Answers Type : Equal

Text Areas : PlainText

Possible Answers :

1

Question Number : 90 Question Id : 86435120079 Question Type : SA

Correct Marks : 4 Wrong Marks : 0

The locus of a point, which moves such that the sum of squares of its distances from the points $(0, 0)$, $(1, 0)$, $(0, 1)$, $(1, 1)$ is 18 units, is a circle of diameter d . Then d^2 is equal to _____.

Response Type : Numeric

Evaluation Required For SA : Yes

Show Word Count : Yes

Answers Type : Equal

Text Areas : PlainText

Possible Answers :

1