

**Question Paper Name :** B Tech 25072021 Shift S2  
**Subject Name :** B TECH  
**Creation Date :** 2021-07-25 19:49:44  
**Duration :** 180  
**Total Marks :** 300  
**Display Marks:** Yes

## B TECH

**Group Number :** 1  
**Group Id :** 864351226  
**Group Maximum Duration :** 0  
**Group Minimum Duration :** 180  
**Show Attended Group? :** No  
**Edit Attended Group? :** No  
**Break time :** 0  
**Group Marks :** 300  
**Is this Group for Examiner? :** No

## Physics Section A

**Section Id :** 864351794  
**Section Number :** 1  
**Section type :** Online  
**Mandatory or Optional :** Mandatory

Number of Questions :	20
Number of Questions to be attempted :	20
Section Marks :	80
Enable Mark as Answered Mark for Review and Clear Response :	Yes
Sub-Section Number :	1
Sub-Section Id :	8643511021
Question Shuffling Allowed :	Yes

Question Number : 1 Question Id : 86435118370 Question Type : MCQ Option Shuffling : Yes Is

Question Mandatory : No

Correct Marks : 4 Wrong Marks : 1

The force is given in terms of time  $t$  and displacement  $x$  by the equation

$$F = A \cos Bx + C \sin Dt$$

The dimensional formula of  $\frac{AD}{B}$  is :

Options :

86435161691.  $[ M^1 L^1 T^{-2} ]$

86435161692.  $[ M^2 L^2 T^{-3} ]$

86435161693.  $[ M^0 L T^{-1} ]$

86435161694.  $[ M L^2 T^{-3} ]$

Question Number : 2 Question Id : 86435118371 Question Type : MCQ Option Shuffling : Yes Is

Question Mandatory : No

Correct Marks : 4 Wrong Marks : 1

A balloon was moving upwards with a uniform velocity of 10 m/s. An object of finite mass is dropped from the balloon when it was at a height of 75 m from the ground level. The height of the balloon from the ground when object strikes the ground was around : (takes the value of  $g$  as  $10 \text{ m/s}^2$ )

**Options :**

86435161695. 125 m

86435161696. 300 m

86435161697. 200 m

86435161698. 250 m

**Question Number : 3 Question Id : 86435118372 Question Type : MCQ Option Shuffling : Yes Is**

**Question Mandatory : No**

**Correct Marks : 4 Wrong Marks : 1**

The instantaneous velocity of a particle moving in a straight line is given as  $v = \alpha t + \beta t^2$ , where  $\alpha$  and  $\beta$  are constants. The distance travelled by the particle between 1 s and 2 s is :

**Options :**

86435161699.  $3\alpha + 7\beta$

86435161700.  $\frac{3}{2}\alpha + \frac{7}{3}\beta$

86435161701.  $\frac{\alpha}{2} + \frac{\beta}{3}$

86435161702.  $\frac{3}{2}\alpha + \frac{7}{2}\beta$

**Question Number : 4 Question Id : 86435118373 Question Type : MCQ Option Shuffling : Yes Is Question Mandatory : No**

**Correct Marks : 4 Wrong Marks : 1**

The relation between time  $t$  and distance  $x$  for a moving body is given as  $t = mx^2 + nx$ , where  $m$  and  $n$  are constants. The retardation of the motion is : (Where  $v$  stands for velocity)

**Options :**

86435161703.  $2 mv^3$

86435161704.  $2 nv^3$

86435161705.  $2 mnv^3$

86435161706.  $2 n^2v^3$

**Question Number : 5 Question Id : 86435118374 Question Type : MCQ Option Shuffling : Yes Is Question Mandatory : No**

**Correct Marks : 4 Wrong Marks : 1**

Two vectors  $\vec{X}$  and  $\vec{Y}$  have equal magnitude. The magnitude of  $(\vec{X} - \vec{Y})$  is  $n$  times the magnitude of  $(\vec{X} + \vec{Y})$ . The angle between  $\vec{X}$  and  $\vec{Y}$  is :

**Options :**

86435161707.  $\cos^{-1} \left( \frac{n^2 - 1}{-n^2 - 1} \right)$

86435161708.

$$\cos^{-1}\left(\frac{-n^2 - 1}{n^2 - 1}\right)$$

86435161709.

$$\cos^{-1}\left(\frac{n^2 + 1}{-n^2 - 1}\right)$$

86435161710.

$$\cos^{-1}\left(\frac{n^2 + 1}{n^2 - 1}\right)$$

**Question Number : 6 Question Id : 86435118375 Question Type : MCQ Option Shuffling : Yes Is Question Mandatory : No**

**Correct Marks : 4 Wrong Marks : 1**

A force  $\vec{F} = (40\hat{i} + 10\hat{j})\text{N}$  acts on a body of mass 5 kg. If the body starts from rest, its

position vector  $\vec{r}$  at time  $t=10$  s, will be :

**Options :**

86435161711.  $(400\hat{i} + 100\hat{j})\text{ m}$

86435161712.  $(100\hat{i} + 400\hat{j})\text{ m}$

86435161713.  $(100\hat{i} + 100\hat{j})\text{ m}$

86435161714.  $(400\hat{i} + 400\hat{j})\text{ m}$

Question Number : 7 Question Id : 86435118376 Question Type : MCQ Option Shuffling : Yes Is

Question Mandatory : No

Correct Marks : 4 Wrong Marks : 1

Consider a planet in some solar system which has a mass double the mass of earth and density equal to the average density of earth. If the weight of an object on earth is  $W$ , the weight of the same object on that planet will be :

Options :

86435161715.  $W$

86435161716.  $2W$

86435161717.  $\sqrt{2}W$

86435161718.  $\frac{1}{2^3}W$

Question Number : 8 Question Id : 86435118377 Question Type : MCQ Option Shuffling : Yes Is

Question Mandatory : No

Correct Marks : 4 Wrong Marks : 1

Two spherical soap bubbles of radii  $r_1$  and  $r_2$  in vacuum combine under isothermal conditions. The resulting bubble has a radius equal to :

Options :

86435161719.  $\frac{r_1 + r_2}{2}$

86435161720.  $\frac{r_1 r_2}{r_1 + r_2}$

86435161721.  $\sqrt{r_1 r_2}$

86435161722.  $\sqrt{r_1^2 + r_2^2}$

**Question Number : 9 Question Id : 86435118378 Question Type : MCQ Option Shuffling : Yes Is Question Mandatory : No**

**Correct Marks : 4 Wrong Marks : 1**

A heat engine has an efficiency of  $\frac{1}{6}$ . When the temperature of sink is reduced by  $62^\circ\text{C}$ , its efficiency get doubled. The temperature of the source is :

**Options :**

86435161723.  $37^\circ\text{C}$

86435161724.  $62^\circ\text{C}$

86435161725.  $99^\circ\text{C}$

86435161726.  $124^\circ\text{C}$

**Question Number : 10 Question Id : 86435118379 Question Type : MCQ Option Shuffling : Yes Is Question Mandatory : No**

**Correct Marks : 4 Wrong Marks : 1**

In a simple harmonic oscillation, what fraction of total mechanical energy is in the form of kinetic energy, when the particle is midway between mean and extreme position.

**Options :**

86435161727.  $\frac{3}{4}$

86435161728.  $\frac{1}{4}$

86435161729.  $\frac{1}{3}$

86435161730.  $\frac{1}{2}$

**Question Number : 11 Question Id : 86435118380 Question Type : MCQ Option Shuffling : Yes Is Question Mandatory : No**

**Correct Marks : 4 Wrong Marks : 1**

If  $q_f$  is the free charge on the capacitor plates and  $q_b$  is the bound charge on the dielectric slab of dielectric constant  $k$  placed between the capacitor plates, then bound charge  $q_b$  can be expressed as :

**Options :**

86435161731.  $q_b = q_f \left( 1 - \frac{1}{k} \right)$

86435161732.  $q_b = q_f \left( 1 - \frac{1}{\sqrt{k}} \right)$

86435161733.  $q_b = q_f \left( 1 + \frac{1}{k} \right)$

86435161734.  $q_b = q_f \left( 1 + \frac{1}{\sqrt{k}} \right)$

Question Number : 12 Question Id : 86435118381 Question Type : MCQ Option Shuffling : Yes  
Is Question Mandatory : No

Correct Marks : 4 Wrong Marks : 1

Two ideal electric dipoles A and B, having their dipole moment  $p_1$  and  $p_2$  respectively are placed on a plane with their centres at O as shown in the figure. At point C on the axis of dipole A, the resultant electric field is making an angle of  $37^\circ$  with the axis.

The ratio of the dipole moment of A and B,  $\frac{p_1}{p_2}$  is : (take  $\sin 37^\circ = \frac{3}{5}$ )

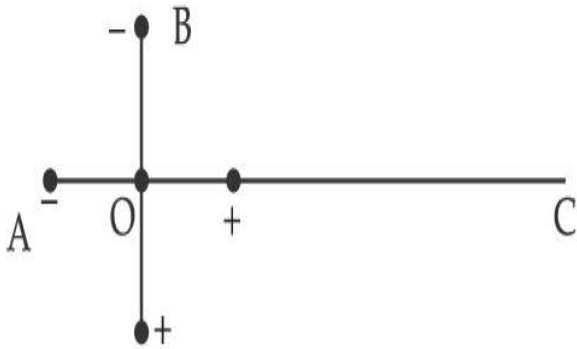

Options :

86435161735.  $\frac{4}{3}$

86435161736.  $\frac{3}{2}$

86435161737.  $\frac{2}{3}$

86435161738.  $\frac{3}{8}$

Question Number : 13 Question Id : 86435118382 Question Type : MCQ Option Shuffling : Yes

Is Question Mandatory : No

Correct Marks : 4 Wrong Marks : 1

The given potentiometer has its wire of resistance  $10\ \Omega$ . When the sliding contact is in the middle of the potentiometer wire, the potential drop across  $2\ \Omega$  resistor is :

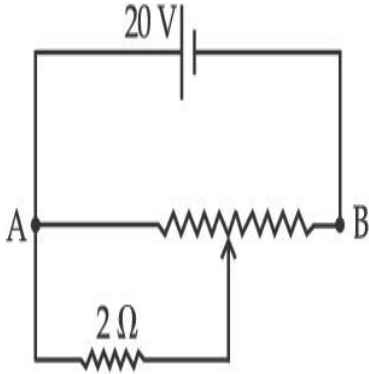

Options :

86435161739.  $10\ \text{V}$

86435161740.  $5\ \text{V}$

86435161741.  $\frac{40}{9}\ \text{V}$

86435161742.  $\frac{40}{11}\ \text{V}$

Question Number : 14 Question Id : 86435118383 Question Type : MCQ Option Shuffling : Yes

Is Question Mandatory : No

Correct Marks : 4 Wrong Marks : 1

Two ions having same mass have charges in the ratio  $1 : 2$ . They are projected normally in a uniform magnetic field with their speeds in the ratio  $2 : 3$ . The ratio of the radii of their circular trajectories is :

Options :

86435161743.  $4 : 3$

86435161744. 2 : 3

86435161745. 3 : 1

86435161746. 1 : 4

**Question Number : 15 Question Id : 86435118384 Question Type : MCQ Option Shuffling : Yes  
Is Question Mandatory : No**

**Correct Marks : 4 Wrong Marks : 1**

A  $10\ \Omega$  resistance is connected across 220 V - 50 Hz AC supply. The time taken by the current to change from its maximum value to the rms value is :

**Options :**

86435161747. 2.5 ms

86435161748. 1.5 ms

86435161749. 4.5 ms

86435161750. 3.0 ms

**Question Number : 16 Question Id : 86435118385 Question Type : MCQ Option Shuffling : Yes  
Is Question Mandatory : No**

**Correct Marks : 4 Wrong Marks : 1**

A ray of light entering from air into a denser medium of refractive index  $\frac{4}{3}$ , as shown in figure. The light ray suffers total internal reflection at the adjacent surface as shown.

The maximum value of angle  $\theta$  should be equal to :

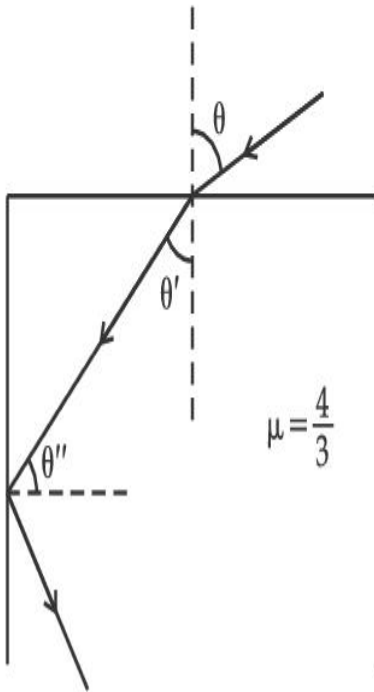

**Options :**

86435161751.  $\sin^{-1} \frac{\sqrt{5}}{3}$

86435161752.  $\sin^{-1} \frac{\sqrt{7}}{3}$

86435161753.  $\sin^{-1} \frac{\sqrt{7}}{4}$

86435161754.  $\sin^{-1} \frac{\sqrt{5}}{4}$

Question Number : 17 Question Id : 86435118386 Question Type : MCQ Option Shuffling : Yes

Is Question Mandatory : No

Correct Marks : 4 Wrong Marks : 1

A prism of refractive index  $\mu$  and angle of prism  $A$  is placed in the position of minimum angle of deviation. If minimum angle of deviation is also  $A$ , then in terms of refractive index value of  $A$  is :

Options :

86435161755.  $\sin^{-1}\left(\frac{\mu}{2}\right)$

86435161756.  $\sin^{-1}\left(\sqrt{\frac{\mu - 1}{2}}\right)$

86435161757.  $2 \cos^{-1}\left(\frac{\mu}{2}\right)$

86435161758.  $\cos^{-1}\left(\frac{\mu}{2}\right)$

Question Number : 18 Question Id : 86435118387 Question Type : MCQ Option Shuffling : Yes

Is Question Mandatory : No

Correct Marks : 4 Wrong Marks : 1

When radiation of wavelength  $\lambda$  is incident on a metallic surface, the stopping potential of ejected photoelectrons is 4.8 V. If the same surface is illuminated by radiation of double the previous wavelength, then the stopping potential becomes 1.6 V. The threshold wavelength of the metal is :

Options :

86435161759.  $2 \lambda$

86435161760.  $4 \lambda$

86435161761.  $6 \lambda$

86435161762.  $8 \lambda$

**Question Number : 19 Question Id : 86435118388 Question Type : MCQ Option Shuffling : Yes**

**Is Question Mandatory : No**

**Correct Marks : 4 Wrong Marks : 1**

An electron moving with speed  $v$  and a photon moving with speed  $c$ , have same D-Broglie wavelength. The ratio of kinetic energy of electron to that of photon is :

**Options :**

86435161763.  $\frac{2c}{v}$

86435161764.  $\frac{v}{2c}$

86435161765.  $\frac{3c}{v}$

86435161766.  $\frac{v}{3c}$

**Question Number : 20 Question Id : 86435118389 Question Type : MCQ Option Shuffling : Yes**

**Is Question Mandatory : No**

**Correct Marks : 4 Wrong Marks : 1**

In the given potentiometer circuit arrangement, the balancing length AC is measured to be 250 cm. When the galvanometer connection is shifted from point (1) to point (2) in the given

diagram, the balancing length becomes 400 cm. The ratio of the emf of two cells,  $\frac{\epsilon_1}{\epsilon_2}$  is :

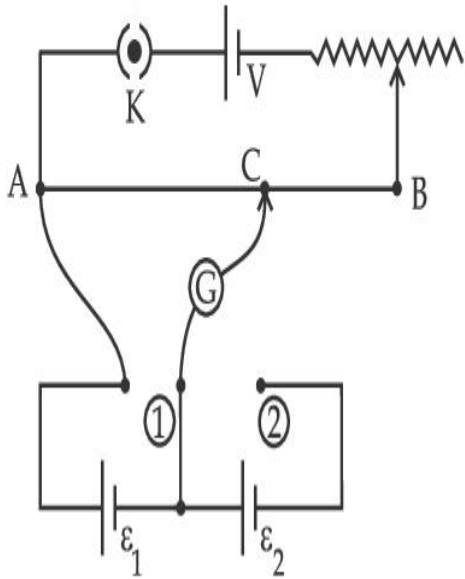

Options :

86435161767.  $\frac{8}{5}$

86435161768.  $\frac{5}{3}$

86435161769.  $\frac{3}{2}$

86435161770.  $\frac{4}{3}$

## Physics Section B

Section Number :	2
Section type :	Online
Mandatory or Optional :	Mandatory
Number of Questions :	10
Number of Questions to be attempted :	5
Section Marks :	20
Enable Mark as Answered Mark for Review and Clear Response :	Yes
Sub-Section Number :	1
Sub-Section Id :	8643511022
Question Shuffling Allowed :	Yes

**Question Number : 21 Question Id : 86435118390 Question Type : SA**

**Correct Marks : 4 Wrong Marks : 0**

A force of  $F = (5y + 20) \hat{j}$  N acts on a particle. The workdone by this force when the particle is moved from  $y = 0$  m to  $y = 10$  m is \_\_\_\_\_ J.

**Response Type :** Numeric

**Evaluation Required For SA :** Yes

**Show Word Count :** Yes

**Answers Type :** Equal

**Text Areas :** PlainText

**Possible Answers :**

1

**Question Number : 22 Question Id : 86435118391 Question Type : SA**

**Correct Marks : 4 Wrong Marks : 0**

A solid disc of radius 20 cm and mass 10 kg is rotating with an angular velocity of 600 rpm, about an axis normal to its circular plane and passing through its centre of mass. The retarding torque required to bring the disc at rest in 10 s is \_\_\_\_\_  $\pi \times 10^{-1}$  Nm.

**Response Type :** Numeric

**Evaluation Required For SA :** Yes

**Show Word Count :** Yes

**Answers Type :** Equal

**Text Areas :** PlainText

**Possible Answers :**

1

**Question Number :** 23 **Question Id :** 86435118392 **Question Type :** SA

**Correct Marks :** 4 **Wrong Marks :** 0

A system consists of two types of gas molecules A and B having same number density  $2 \times 10^{25}/\text{m}^3$ . The diameter of A and B are  $10 \text{ \AA}$  and  $5 \text{ \AA}$  respectively. They suffer collision at room temperature. The ratio of average distance covered by the molecule A to that of B between two successive collision is \_\_\_\_\_  $\times 10^{-2}$ .

**Response Type :** Numeric

**Evaluation Required For SA :** Yes

**Show Word Count :** Yes

**Answers Type :** Equal

**Text Areas :** PlainText

**Possible Answers :**

1

**Question Number :** 24 **Question Id :** 86435118393 **Question Type :** SA

**Correct Marks :** 4 **Wrong Marks :** 0

A  $16 \Omega$  wire is bend to form a square loop. A  $9 \text{ V}$  supply having internal resistance of  $1 \Omega$  is connected across one of its sides. The potential drop across the diagonals of the square loop is \_\_\_\_\_  $\times 10^{-1} \text{ V}$ .

**Response Type :** Numeric

**Evaluation Required For SA :** Yes

**Show Word Count :** Yes

**Answers Type :** Equal

**Text Areas :** PlainText

Possible Answers :

1

Question Number : 25 Question Id : 86435118394 Question Type : SA

Correct Marks : 4 Wrong Marks : 0

Two circuits are shown in the figure (a) & (b). At a frequency of \_\_\_\_\_ rad/s the average power dissipated in one cycle will be same in both the circuits.

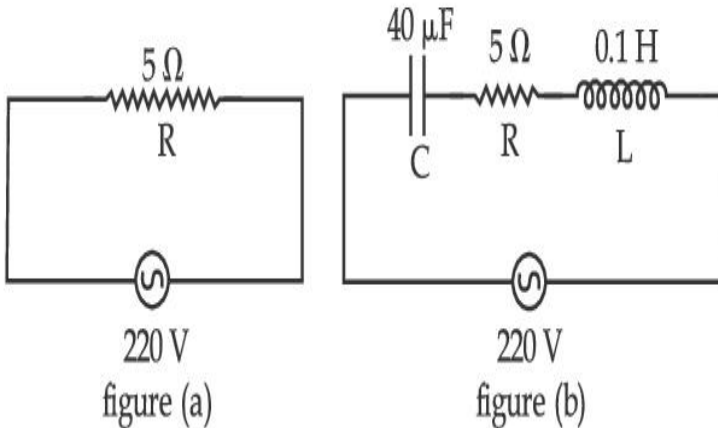

Response Type : Numeric

Evaluation Required For SA : Yes

Show Word Count : Yes

Answers Type : Equal

Text Areas : PlainText

Possible Answers :

1

Question Number : 26 Question Id : 86435118395 Question Type : SA

Correct Marks : 4 Wrong Marks : 0

A light beam of wavelength 500 nm is incident on a metal having work function of 1.25 eV, placed in a magnetic field of intensity  $B$ . The electrons emitted perpendicular to the magnetic field  $B$ , with maximum kinetic energy are bent into circular arc of radius 30 cm. The value of  $B$  is \_\_\_\_\_  $\times 10^{-7}$  T.

Given  $hc = 20 \times 10^{-26}$  J-m, mass of electron =  $9 \times 10^{-31}$  kg

Response Type : Numeric

Evaluation Required For SA : Yes

**Show Word Count :** Yes

**Answers Type :** Equal

**Text Areas :** PlainText

**Possible Answers :**

1

**Question Number :** 27 **Question Id :** 86435118396 **Question Type :** SA

**Correct Marks :** 4 **Wrong Marks :** 0

The nuclear activity of a radioactive element becomes  $\left(\frac{1}{8}\right)^{\text{th}}$  of its initial value in 30 years.

The half-life of radioactive element is \_\_\_\_\_ years.

**Response Type :** Numeric

**Evaluation Required For SA :** Yes

**Show Word Count :** Yes

**Answers Type :** Equal

**Text Areas :** PlainText

**Possible Answers :**

1

**Question Number :** 28 **Question Id :** 86435118397 **Question Type :** SA

**Correct Marks :** 4 **Wrong Marks :** 0

From the given data, the amount of energy required to break the nucleus of aluminium

${}_{13}^{27}\text{Al}$  is \_\_\_\_\_  $\times 10^{-3}$  J.

Mass of neutron = 1.00866 u

Mass of proton = 1.00726 u

Mass of Aluminium nucleus = 27.18846 u

(Assume 1 u corresponds to x J of energy)

(Round off to the nearest integer)

**Response Type :** Numeric

**Evaluation Required For SA :** Yes

**Show Word Count :** Yes

**Answers Type :** Equal

**Text Areas :** PlainText

**Possible Answers :**

1

**Question Number :** 29 **Question Id :** 86435118398 **Question Type :** SA

**Correct Marks :** 4 **Wrong Marks :** 0

In a semiconductor, the number density of intrinsic charge carriers at  $27^{\circ}\text{C}$  is  $1.5 \times 10^{16}/\text{m}^3$ . If the semiconductor is doped with impurity atom, the hole density increases to  $4.5 \times 10^{22}/\text{m}^3$ . The electron density in the doped semiconductor is \_\_\_\_\_  $\times 10^9/\text{m}^3$ .

**Response Type :** Numeric

**Evaluation Required For SA :** Yes

**Show Word Count :** Yes

**Answers Type :** Equal

**Text Areas :** PlainText

**Possible Answers :**

1

**Question Number :** 30 **Question Id :** 86435118399 **Question Type :** SA

**Correct Marks :** 4 **Wrong Marks :** 0

A message signal of frequency 20 kHz and peak voltage of 20 volt is used to modulate a carrier wave of frequency 1 MHz and peak voltage of 20 volt. The modulation index will be \_\_\_\_\_.

**Response Type :** Numeric

**Evaluation Required For SA :** Yes

**Show Word Count :** Yes

**Answers Type :** Equal

**Text Areas :** PlainText

## Chemistry Section A

Section Id :	864351796
Section Number :	3
Section type :	Online
Mandatory or Optional :	Mandatory
Number of Questions :	20
Number of Questions to be attempted :	20
Section Marks :	80
Enable Mark as Answered Mark for Review and Clear Response :	Yes
Sub-Section Number :	1
Sub-Section Id :	8643511023
Question Shuffling Allowed :	Yes

Question Number : 31 Question Id : 86435118400 Question Type : MCQ Option Shuffling : Yes

Is Question Mandatory : No

Correct Marks : 4 Wrong Marks : 1

In the following the correct bond order sequence is :

Options :

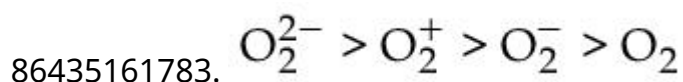
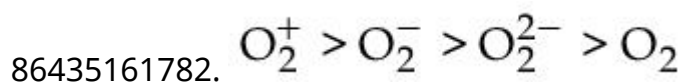
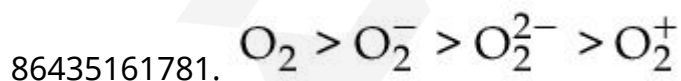

86435161784.  $O_2^+ > O_2 > O_2^- > O_2^{2-}$

Question Number : 32 Question Id : 86435118401 Question Type : MCQ Option Shuffling : Yes

Is Question Mandatory : No

Correct Marks : 4 Wrong Marks : 1

Identify the process in which change in the oxidation state is five :

Options :

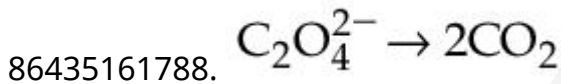
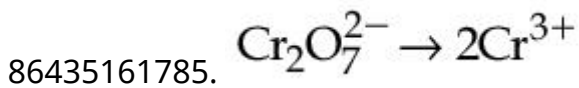

Question Number : 33 Question Id : 86435118402 Question Type : MCQ Option Shuffling : Yes

Is Question Mandatory : No

Correct Marks : 4 Wrong Marks : 1

Match List I with List II :

List - I

List - II

Example of Colloids

Classification

- |                  |                                    |
|------------------|------------------------------------|
| (a) Cheese       | (i) dispersion of liquid in liquid |
| (b) Pumice stone | (ii) dispersion of liquid in gas   |
| (c) Hair cream   | (iii) dispersion of gas in solid   |
| (d) Cloud        | (iv) dispersion of liquid in solid |

Choose the most appropriate answer from the options given below :

Options :

86435161789. (a) - (iv), (b) - (iii), (c) - (ii), (d) - (i)

86435161790. (a) - (iii), (b) - (iv), (c) - (i), (d) - (ii)

86435161791. (a) - (iv), (b) - (i), (c) - (iii), (d) - (ii)

86435161792. (a) - (iv), (b) - (iii), (c) - (i), (d) - (ii)

Question Number : 34 Question Id : 86435118403 Question Type : MCQ Option Shuffling : Yes

Is Question Mandatory : No

Correct Marks : 4 Wrong Marks : 1

The ionic radii of  $F^-$  and  $O^{2-}$  respectively are  $1.33 \text{ \AA}$  and  $1.4 \text{ \AA}$ , while the covalent radius of N is  $0.74 \text{ \AA}$ .

The correct statement for the ionic radius of  $N^{3-}$  from the following is :

Options :

86435161793. It is smaller than  $O^{2-}$  and  $F^-$ , but bigger than of N

86435161794. It is bigger than  $O^{2-}$  and  $F^-$

86435161795. It is bigger than  $F^-$  and N, but smaller than of  $O^{2-}$

86435161796. It is smaller than  $F^-$  and N

Question Number : 35 Question Id : 86435118404 Question Type : MCQ Option Shuffling : Yes

Is Question Mandatory : No

Correct Marks : 4 Wrong Marks : 1

Match List I with List II : (Both having metallurgical terms)

List - I

List - II

- |                             |  |
|-----------------------------|--|
| (a) Concentration of Ag ore | (i) Reverberatory furnace                |
| (b) Blast furnace           | (ii) Pig iron                            |
| (c) Blister copper          | (iii) Leaching with dilute NaCN solution |
| (d) Froth floatation method | (iv) Sulfide ores                        |

Choose the correct answer from the options given below :

Options :

86435161797. (a) - (iii), (b) - (ii), (c) - (i), (d) - (iv)

86435161798. (a) - (iv), (b) - (iii), (c) - (ii), (d) - (i)

86435161799. (a) - (iii), (b) - (iv), (c) - (i), (d) - (ii)

86435161800. (a) - (iv), (b) - (i), (c) - (iii), (d) - (ii)

Question Number : 36 Question Id : 86435118405 Question Type : MCQ Option Shuffling : Yes

Is Question Mandatory : No

Correct Marks : 4 Wrong Marks : 1

Which one of the following metals forms interstitial hydride easily ?

Options :

86435161801. Fe

86435161802. Co

86435161803. Cr

Question Number : 37 Question Id : 86435118406 Question Type : MCQ Option Shuffling : Yes

Is Question Mandatory : No

Correct Marks : 4 Wrong Marks : 1

Match List I with List II :

List - I Elements	List - II Properties
(a) Li	(i) Poor water solubility of $I^-$ salt
(b) Na	(ii) Most abundant element in cell fluid
(c) K	(iii) Bicarbonate salt used in fire extinguisher
(d) Cs	(iv) Carbonate salt decomposes easily on heating

Choose the correct answer from the options given below :

Options :

86435161805. (a) - (iv), (b) - (ii), (c) - (iii), (d) - (i)

86435161806. (a) - (iv), (b) - (iii), (c) - (ii), (d) - (i)

86435161807. (a) - (i), (b) - (ii), (c) - (iii), (d) - (iv)

86435161808. (a) - (i), (b) - (iii), (c) - (ii), (d) - (iv)

Question Number : 38 Question Id : 86435118407 Question Type : MCQ Option Shuffling : Yes

Is Question Mandatory : No

Correct Marks : 4 Wrong Marks : 1

Identify the species having one  $\pi$ -bond and maximum number of canonical forms from the following :

Options :

86435161809.  $\text{SO}_3$

86435161810.  $\text{SO}_2$

86435161811.  $\text{O}_2$

86435161812.  $\text{CO}_3^{2-}$

**Question Number : 39 Question Id : 86435118408 Question Type : MCQ Option Shuffling : Yes**

**Is Question Mandatory : No**

**Correct Marks : 4 Wrong Marks : 1**

The spin only magnetic moments (in BM) for free  $\text{Ti}^{3+}$ ,  $\text{V}^{2+}$  and  $\text{Sc}^{3+}$  ions respectively are  
(At. No. Sc : 21 ; Ti : 22 ; V : 23)

**Options :**

86435161813. 0, 3.87, 1.73

86435161814. 1.73, 0, 3.87

86435161815. 3.87, 1.73, 0

86435161816. 1.73, 3.87, 0

**Question Number : 40 Question Id : 86435118409 Question Type : MCQ Option Shuffling : Yes**

**Is Question Mandatory : No**

**Correct Marks : 4 Wrong Marks : 1**

Which one of the following metal complexes is most stable ?

Options :

86435161817.  $[\text{Co}(\text{NH}_3)_6]\text{Cl}_2$

86435161818.  $[\text{Co}(\text{en})_3]\text{Cl}_2$

86435161819.  $[\text{Co}(\text{en})_2(\text{NH}_3)_2]\text{Cl}_2$

86435161820.  $[\text{Co}(\text{en})(\text{NH}_3)_4]\text{Cl}_2$

Question Number : 41 Question Id : 86435118410 Question Type : MCQ Option Shuffling : Yes

Is Question Mandatory : No

Correct Marks : 4 Wrong Marks : 1

Given below are two statements :

**Statement I :** Chlorofluoro carbons breakdown by radiation in the visible energy region and release chlorine gas in the atmosphere which then reacts with stratospheric ozone.

**Statement II :** Atmospheric ozone reacts with nitric oxide to give nitrogen and oxygen gases, which add to the atmosphere.

For the above statements choose the correct answer from the options given below :

Options :

86435161821. Both **statement I** and **statement II** are correct

86435161822. Both **statement I** and **statement II** are false

86435161823. **Statement I** is correct but **statement II** is false

86435161824. **Statement I** is incorrect but **statement II** is true

Question Number : 42 Question Id : 86435118411 Question Type : MCQ Option Shuffling : Yes

Is Question Mandatory : No

Correct Marks : 4 Wrong Marks : 1

Which among the following is the strongest acid ?

Options :

86435161825.

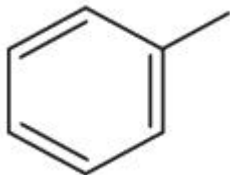

86435161826.



86435161827.

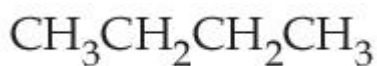

86435161828.



Question Number : 43 Question Id : 86435118412 Question Type : MCQ Option Shuffling : Yes

Is Question Mandatory : No

Correct Marks : 4 Wrong Marks : 1

The correct decreasing order of densities of the following compounds is :

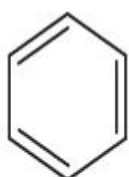

(A)

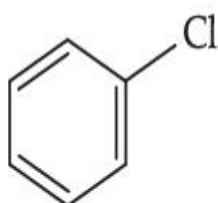

(B)

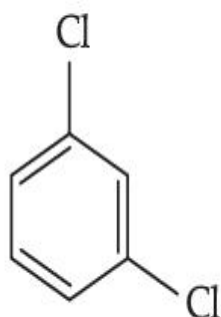

(C)

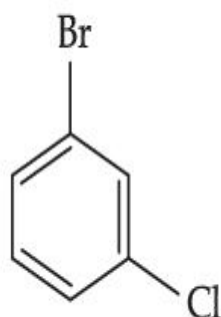

(D)

Options :

86435161829. (D) > (C) > (B) > (A)

86435161830. (C) > (B) > (A) > (D)

86435161831. (A) > (B) > (C) > (D)

86435161832. (C) > (D) > (A) > (B)

Question Number : 44 Question Id : 86435118413 Question Type : MCQ Option Shuffling : Yes

Is Question Mandatory : No

Correct Marks : 4 Wrong Marks : 1

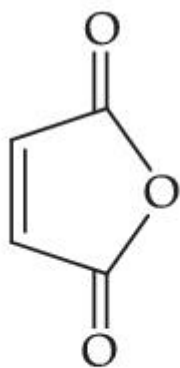

Maleic anhydride

Maleic anhydride can be prepared by :

Options :

86435161833. Heating trans-but-2-enedioic acid

86435161834. Heating cis-but-2-enedioic acid

86435161835. Treating trans-but-2-enedioic acid with alcohol and acid

86435161836. Treating cis-but-2-enedioic acid with alcohol and acid



Is Question Mandatory : No

Correct Marks : 4 Wrong Marks : 1

What is the major product "P" of the following reaction ?

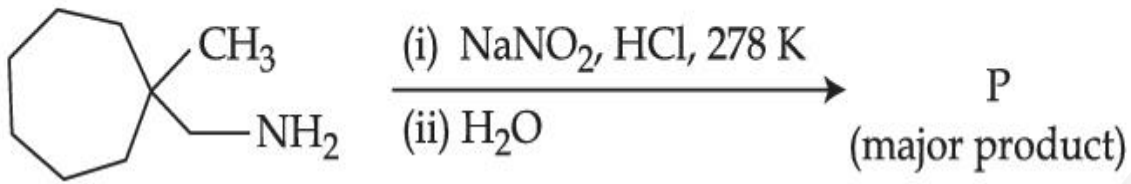

Options :

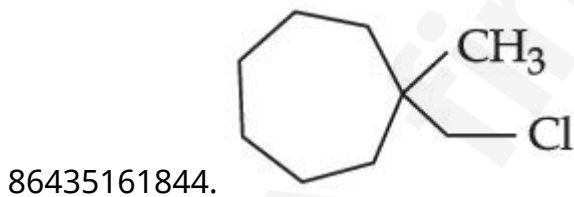
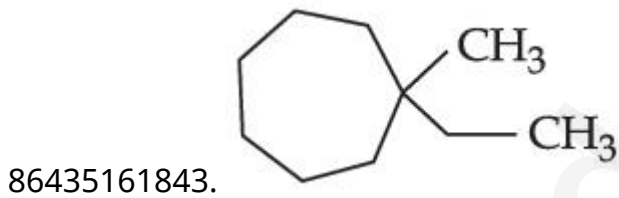
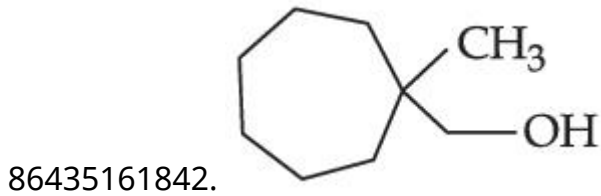

Question Number : 47 Question Id : 86435118416 Question Type : MCQ Option Shuffling : Yes

Is Question Mandatory : No

Correct Marks : 4 Wrong Marks : 1

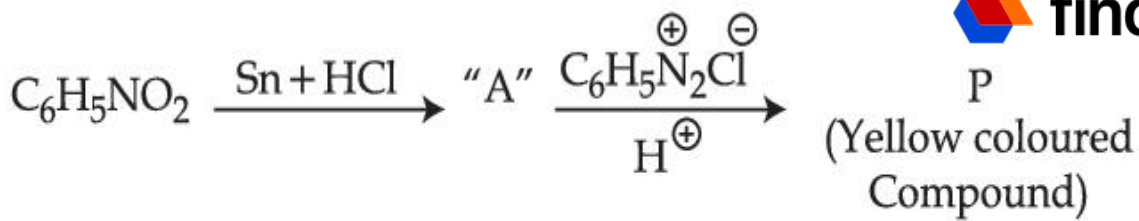

Consider the above reaction, the Product "P" is :

Options :

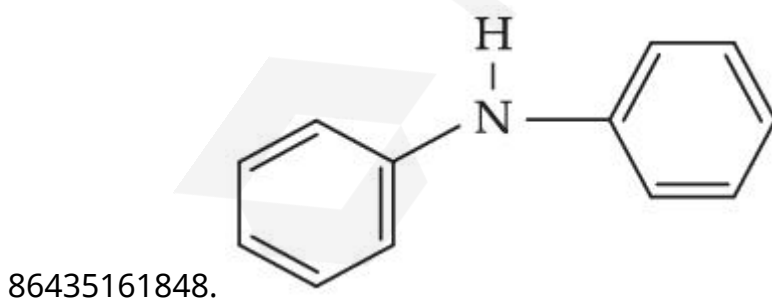
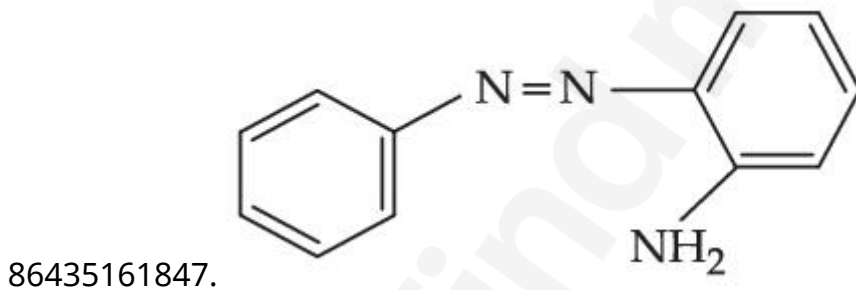
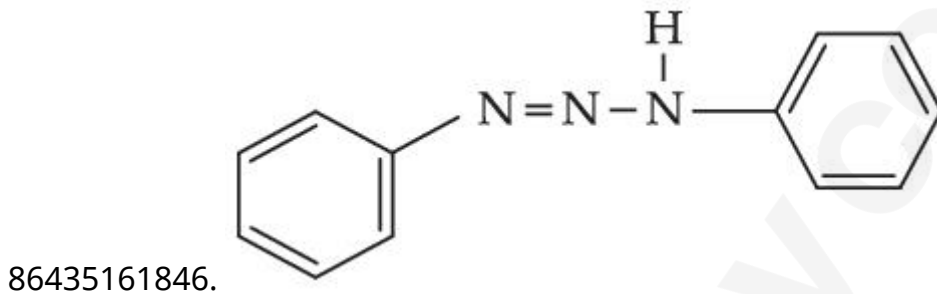
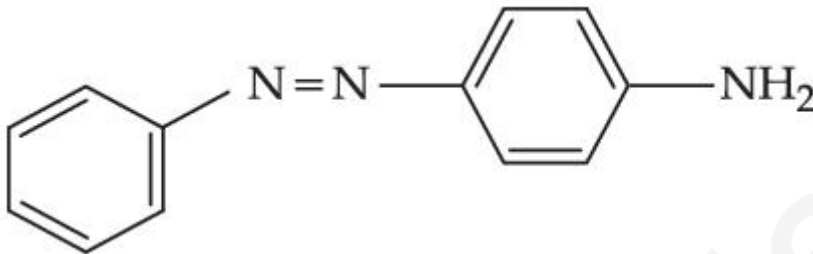

Question Number : 48 Question Id : 86435118417 Question Type : MCQ Option Shuffling : Yes

Is Question Mandatory : No

Correct Marks : 4 Wrong Marks : 1

A biodegradable polyamide can be made from  find my college

Options :

86435161849. Glycine and aminocaproic acid

86435161850. Glycine and isoprene

86435161851. Styrene and caproic acid

86435161852. Hexamethylene diamine and adipic acid

Question Number : 49 Question Id : 86435118418 Question Type : MCQ Option Shuffling : Yes

Is Question Mandatory : No

Correct Marks : 4 Wrong Marks : 1

Which one of the following is correct structure for cytosine ?

Options :

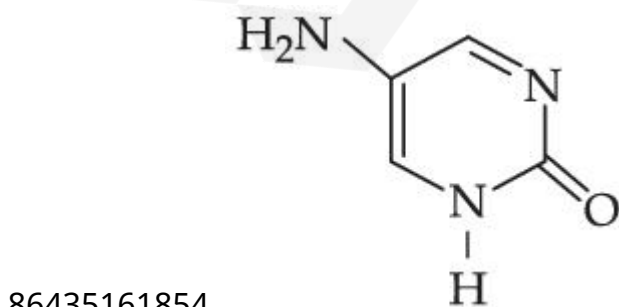
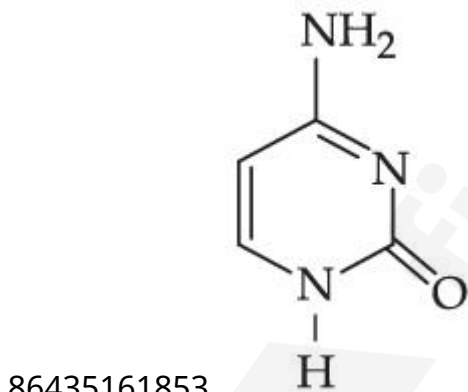

86435161855.

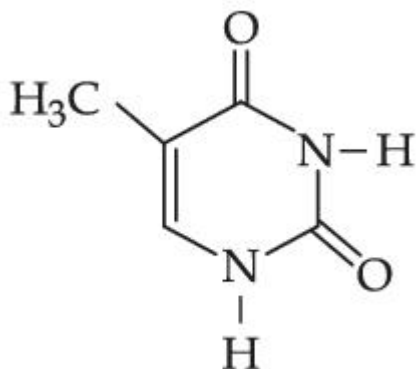
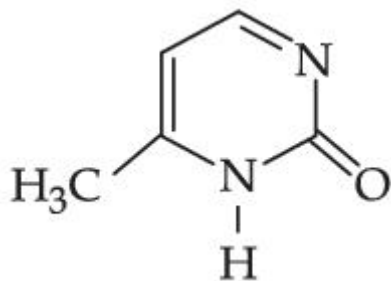

86435161856.

**Question Number : 50 Question Id : 86435118419 Question Type : MCQ Option Shuffling : Yes**

**Is Question Mandatory : No**

**Correct Marks : 4 Wrong Marks : 1**

A reaction of benzonitrile with one equivalent  $\text{CH}_3\text{MgBr}$  followed by hydrolysis produces a yellow liquid "P". The compound "P" will give positive \_\_\_\_\_.

**Options :**

86435161857. Tollen's test

86435161858. Ninhydrin's test

86435161859. Iodoform test

86435161860. Schiff's test

**Section Id :** 86435179  
**Section Number :** 4  
**Section type :** Online  
**Mandatory or Optional :** Mandatory  
**Number of Questions :** 10  
**Number of Questions to be attempted :** 5  
**Section Marks :** 20  
**Enable Mark as Answered Mark for Review and Clear Response :** Yes  
**Sub-Section Number :** 1  
**Sub-Section Id :** 8643511024  
**Question Shuffling Allowed :** Yes

**Question Number : 51 Question Id : 86435118420 Question Type : SA**

**Correct Marks : 4 Wrong Marks : 0**

The number of significant figures in 0.00340 is \_\_\_\_\_.

**Response Type :** Numeric

**Evaluation Required For SA :** Yes

**Show Word Count :** Yes

**Answers Type :** Equal

**Text Areas :** PlainText

**Possible Answers :**

1

**Question Number : 52 Question Id : 86435118421 Question Type : SA**

**Correct Marks : 4 Wrong Marks : 0**

An LPG cylinder contains gas at a pressure of 300 kPa at 27°C. The cylinder can withstand the pressure of  $1.2 \times 10^6$  Pa. The room in which the cylinder is kept catches fire. The minimum temperature at which the bursting of cylinder will take place is \_\_\_\_\_ °C. (Nearest integer)

**Response Type :** Numeric

**Evaluation Required For SA :** Yes

**Show Word Count :** Yes

**Answers Type :** Equal

**Text Areas :** PlainText

**Possible Answers :**

1

**Question Number : 53 Question Id : 86435118422 Question Type : SA**

**Correct Marks : 4 Wrong Marks : 0**

An accelerated electron has a speed of  $5 \times 10^6 \text{ ms}^{-1}$  with an uncertainty of 0.02%. The uncertainty in finding its location while in motion is  $x \times 10^{-9} \text{ m}$ . The value of  $x$  is \_\_\_\_\_.  
(Nearest integer)

[Use mass of electron =  $9.1 \times 10^{-31} \text{ kg}$ ,  $h = 6.63 \times 10^{-34} \text{ Js}$ ,  $\pi = 3.14$ ]

**Response Type :** Numeric

**Evaluation Required For SA :** Yes

**Show Word Count :** Yes

**Answers Type :** Equal

**Text Areas :** PlainText

**Possible Answers :**

1

**Question Number : 54 Question Id : 86435118423 Question Type : SA**

**Correct Marks : 4 Wrong Marks : 0**

A system does 200 J of work and at the same time absorbs 150 J of heat. The magnitude of the change in internal energy is \_\_\_\_\_ J. (Nearest integer)

**Response Type :** Numeric

**Evaluation Required For SA :** Yes

**Show Word Count :** Yes

**Answers Type :** Equal

**Text Areas :** PlainText

**Possible Answers :**

1

**Question Number : 55 Question Id : 86435118424 Question Type : SA**

**Correct Marks : 4 Wrong Marks : 0**

When 3.00 g of a substance 'X' is dissolved in 100 g of  $\text{CCl}_4$ , it raises the boiling point by 0.60 K. The molar mass of the substance 'X' is \_\_\_\_\_  $\text{g mol}^{-1}$ . (Nearest integer)

[Given  $K_b$  for  $\text{CCl}_4$  is  $5.0 \text{ K kg mol}^{-1}$ ]

**Response Type :** Numeric

**Evaluation Required For SA :** Yes

**Show Word Count :** Yes

**Answers Type :** Equal

**Text Areas :** PlainText

**Possible Answers :**

1

**Question Number : 56 Question Id : 86435118425 Question Type : SA**

**Correct Marks : 4 Wrong Marks : 0**

Assuming that  $\text{Ba}(\text{OH})_2$  is completely ionised in aqueous solution under the given conditions the concentration of  $\text{H}_3\text{O}^+$  ions in 0.005 M aqueous solution of  $\text{Ba}(\text{OH})_2$  at 298 K is \_\_\_\_\_  $\times 10^{-12} \text{ mol L}^{-1}$ . (Nearest integer)

**Response Type :** Numeric

**Evaluation Required For SA :** Yes

**Show Word Count :** Yes

**Answers Type :** Equal

**Text Areas :** PlainText

**Possible Answers :**

1

Question Number : 57 Question Id : 86435118426 Question Type : SA

Correct Marks : 4 Wrong Marks : 0

For a chemical reaction  $A \rightarrow B$ , it was found that concentration of B is increased by  $0.2 \text{ mol L}^{-1}$  in 30 min. The average rate of the reaction is \_\_\_\_\_  $\times 10^{-1} \text{ mol L}^{-1} \text{ h}^{-1}$ , (in nearest integer)

Response Type : Numeric

Evaluation Required For SA : Yes

Show Word Count : Yes

Answers Type : Equal

Text Areas : PlainText

Possible Answers :

1

Question Number : 58 Question Id : 86435118427 Question Type : SA

Correct Marks : 4 Wrong Marks : 0

Number of electrons present in 4f orbital of  $\text{Ho}^{3+}$  ion is \_\_\_\_\_. (Given Atomic No. of Ho = 67)

Response Type : Numeric

Evaluation Required For SA : Yes

Show Word Count : Yes

Answers Type : Equal

Text Areas : PlainText

Possible Answers :

1

Question Number : 59 Question Id : 86435118428 Question Type : SA

Correct Marks : 4 Wrong Marks : 0

0.8 g of an organic compound was analysed by Kjeldahl's method for the estimation of nitrogen. If the percentage of nitrogen in the compound was found to be 42%, then \_\_\_\_\_ mL of 1 M  $\text{H}_2\text{SO}_4$  would have been neutralized by the ammonia evolved during the analysis.

**Response Type :** Numeric

**Evaluation Required For SA :** Yes

**Show Word Count :** Yes

**Answers Type :** Equal

**Text Areas :** PlainText

**Possible Answers :**

1

**Question Number :** 60 **Question Id :** 86435118429 **Question Type :** SA

**Correct Marks :** 4 **Wrong Marks :** 0

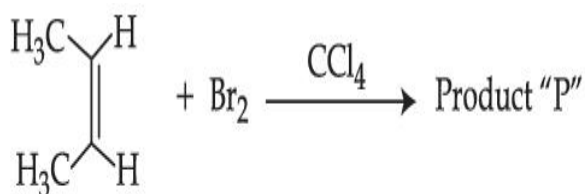

Consider the above chemical reaction. The total number of stereoisomers possible for Product 'P' is \_\_\_\_\_.

**Response Type :** Numeric

**Evaluation Required For SA :** Yes

**Show Word Count :** Yes

**Answers Type :** Equal

**Text Areas :** PlainText

**Possible Answers :**

1

## Mathematics Section A

Section Number : 5  
Section type : Online  
Mandatory or Optional : Mandatory  
Number of Questions : 20  
Number of Questions to be attempted : 20  
Section Marks : 80  
Enable Mark as Answered Mark for Review and Clear Response : Yes  
Sub-Section Number : 1  
Sub-Section Id : 8643511025  
Question Shuffling Allowed : Yes

Question Number : 61 Question Id : 86435118430 Question Type : MCQ Option Shuffling : Yes  
Is Question Mandatory : No  
Correct Marks : 4 Wrong Marks : 1

The number of distinct real roots of  $\begin{vmatrix} \sin x & \cos x & \cos x \\ \cos x & \sin x & \cos x \\ \cos x & \cos x & \sin x \end{vmatrix} = 0$  in the interval  $-\frac{\pi}{4} \leq x \leq \frac{\pi}{4}$  is :

Options :

86435161871. 1

86435161872. 2

86435161873. 3

86435161874. 4

Question Number : 62 Question Id : 86435118431 Question Type : MCQ Option Shuffling : Yes  
Is Question Mandatory : No

Correct Marks : 4 Wrong Marks : 1

The lowest integer which is greater than  $\left(1 + \frac{1}{10^{100}}\right)^{10^{100}}$  is \_\_\_\_\_.

Options :

86435161875. 1

86435161876. 2

86435161877. 3

86435161878. 4

Question Number : 63 Question Id : 86435118432 Question Type : MCQ Option Shuffling : Yes

Is Question Mandatory : No

Correct Marks : 4 Wrong Marks : 1

If  ${}^n P_r = {}^n P_{r+1}$  and  ${}^n C_r = {}^n C_{r-1}$ , then the value of r is equal to :

Options :

86435161879. 1

86435161880. 2

86435161881. 3

86435161882. 4

Question Number : 64 Question Id : 86435118433 Question Type : MCQ Option Shuffling : Yes

Is Question Mandatory : No

Correct Marks : 4 Wrong Marks : 1

If  $[x]$  be the greatest integer less than or equal to  $x$ , then  $\sum_{n=8}^{100} \left[ \frac{(-1)^n n}{2} \right]$  is equal to :

Options :

86435161883. - 2

86435161884. 0

86435161885. 2

86435161886. 4

Question Number : 65 Question Id : 86435118434 Question Type : MCQ Option Shuffling : Yes

Is Question Mandatory : No

Correct Marks : 4 Wrong Marks : 1

Consider the statement "The match will be played only if the weather is good and ground is not wet". Select the correct negation from the following :

Options :

86435161887. The match will not be played or weather is good and ground is not wet.

86435161888. The match will not be played and weather is not good and ground is wet.

86435161889. If the match will not be played, then either weather is not good or ground is wet.

86435161890. The match will be played and weather is not good or ground is wet.

Question Number : 66 Question Id : 86435118435 Question Type : MCQ Option Shuffling : Yes

**Is Question Mandatory : No**

**Correct Marks : 4 Wrong Marks : 1**

The sum of all those terms which are rational numbers in the expansion of  $(2^{1/3} + 3^{1/4})^{12}$  is :

**Options :**

86435161891. 89

86435161892. 35

86435161893. 43

86435161894. 27

**Question Number : 67 Question Id : 86435118436 Question Type : MCQ Option Shuffling : Yes**

**Is Question Mandatory : No**

**Correct Marks : 4 Wrong Marks : 1**

Let  $y=y(x)$  be the solution of the differential equation  $xdy=(y+x^3 \cos x)dx$  with  $y(\pi)=0$ ,

then  $y\left(\frac{\pi}{2}\right)$  is equal to :

**Options :**

86435161895.  $\frac{\pi^2}{2} + \frac{\pi}{4}$

86435161896.  $\frac{\pi^2}{4} - \frac{\pi}{2}$

86435161897.  $\frac{\pi^2}{2} - \frac{\pi}{4}$

86435161898.  $\frac{\pi^2}{4} + \frac{\pi}{2}$

**Question Number : 68 Question Id : 86435118437 Question Type : MCQ Option Shuffling : Yes  
Is Question Mandatory : No**

**Correct Marks : 4 Wrong Marks : 1**

The first of the two samples in a group has 100 items with mean 15 and standard deviation 3. If the whole group has 250 items with mean 15.6 and standard deviation  $\sqrt{13.44}$ , then the standard deviation of the second sample is :

**Options :**

86435161899. 8

86435161900. 6

86435161901. 5

86435161902. 4

**Question Number : 69 Question Id : 86435118438 Question Type : MCQ Option Shuffling : Yes  
Is Question Mandatory : No**

**Correct Marks : 4 Wrong Marks : 1**

The value of the integral  $\int_{-1}^1 \log (x + \sqrt{x^2 + 1}) dx$  is :

**Options :**

86435161903. 0

86435161904. 1

86435161905. 2

86435161906. - 1

**Question Number : 70 Question Id : 86435118439 Question Type : MCQ Option Shuffling : Yes**

**Is Question Mandatory : No**

**Correct Marks : 4 Wrong Marks : 1**

Let  $X$  be a random variable such that the probability function of a distribution is given by

$P(X = 0) = \frac{1}{2}$ ,  $P(X = j) = \frac{1}{3^j}$  ( $j = 1, 2, 3, \dots, \infty$ ) Then the mean of the distribution and

$P(X \text{ is positive and even})$  respectively are :

**Options :**

86435161907.  $\frac{3}{4}$  and  $\frac{1}{8}$

86435161908.  $\frac{3}{4}$  and  $\frac{1}{16}$

86435161909.  $\frac{3}{8}$  and  $\frac{1}{8}$

86435161910.  $\frac{3}{4}$  and  $\frac{1}{9}$

**Question Number : 71 Question Id : 86435118440 Question Type : MCQ Option Shuffling : Yes**

**Is Question Mandatory : No**

Correct Marks : 4 Wrong Marks : 1

If the greatest value of the term independent of 'x' in the expansion of  $\left(x \sin \alpha + a \frac{\cos \alpha}{x}\right)^{10}$  is

$\frac{10!}{(5!)^2}$ , then the value of 'a' is equal to :

Options :

86435161911. 1

86435161912. 2

86435161913. -1

86435161914. -2

Question Number : 72 Question Id : 86435118441 Question Type : MCQ Option Shuffling : Yes

Is Question Mandatory : No

Correct Marks : 4 Wrong Marks : 1

If  $f(x) = \begin{cases} \int_0^x (5 + |1 - t|) dt, & x > 2 \\ 5x + 1, & x \leq 2 \end{cases}$ , then

Options :

86435161915.  $f(x)$  is not continuous at  $x = 2$

86435161916.  $f(x)$  is continuous but not differentiable at  $x = 2$

86435161917.  $f(x)$  is everywhere differentiable

86435161918.  $f(x)$  is not differentiable at  $x=1$

Question Number : 73 Question Id : 86435118442 Question Type : MCQ Option Shuffling : Yes

Is Question Mandatory : No

Correct Marks : 4 Wrong Marks : 1

The value of  $\cot\frac{\pi}{24}$  is :

Options :

86435161919.  $\sqrt{2} + \sqrt{3} + 2 - \sqrt{6}$

86435161920.  $\sqrt{2} + \sqrt{3} + 2 + \sqrt{6}$

86435161921.  $3\sqrt{2} - \sqrt{3} - \sqrt{6}$

86435161922.  $\sqrt{2} - \sqrt{3} - 2 + \sqrt{6}$

Question Number : 74 Question Id : 86435118443 Question Type : MCQ Option Shuffling : Yes

Is Question Mandatory : No

Correct Marks : 4 Wrong Marks : 1

The number of real solutions of the equation,  $x^2 - |x| - 12 = 0$  is :

Options :

86435161923. 1

86435161924. 2

86435161925. 3

**Question Number : 75 Question Id : 86435118444 Question Type : MCQ Option Shuffling : Yes  
Is Question Mandatory : No**

**Correct Marks : 4 Wrong Marks : 1**

If  $P = \begin{bmatrix} 1 & 0 \\ 1/2 & 1 \end{bmatrix}$ , then  $P^{50}$  is :

**Options :**

86435161927.  $\begin{bmatrix} 1 & 0 \\ 50 & 1 \end{bmatrix}$

86435161928.  $\begin{bmatrix} 1 & 25 \\ 0 & 1 \end{bmatrix}$

86435161929.  $\begin{bmatrix} 1 & 0 \\ 25 & 1 \end{bmatrix}$

86435161930.  $\begin{bmatrix} 1 & 50 \\ 0 & 1 \end{bmatrix}$

**Question Number : 76 Question Id : 86435118445 Question Type : MCQ Option Shuffling : Yes  
Is Question Mandatory : No**

**Correct Marks : 4 Wrong Marks : 1**

If a tangent to the ellipse  $x^2 + 4y^2 = 4$  meets the tangents at the extremities of its major axis at B and C, then the circle with BC as diameter passes through the point :

**Options :**

86435161931.

$(\sqrt{3}, 0)$

86435161932.  $(1, 1)$

86435161933.  $(-1, 1)$

86435161934.  $(\sqrt{2}, 0)$

**Question Number : 77 Question Id : 86435118446 Question Type : MCQ Option Shuffling : Yes**

**Is Question Mandatory : No**

**Correct Marks : 4 Wrong Marks : 1**

Let the equation of the pair of lines,  $y = px$  and  $y = qx$ , can be written as  $(y - px)(y - qx) = 0$ .  
Then the equation of the pair of the angle bisectors of the lines  $x^2 - 4xy - 5y^2 = 0$  is :

**Options :**

86435161935.  $x^2 - 3xy - y^2 = 0$

86435161936.  $x^2 + 3xy - y^2 = 0$

86435161937.  $x^2 - 3xy + y^2 = 0$

86435161938.  $x^2 + 4xy - y^2 = 0$

**Question Number : 78 Question Id : 86435118447 Question Type : MCQ Option Shuffling : Yes**

**Is Question Mandatory : No**

**Correct Marks : 4 Wrong Marks : 1**

If  $|\vec{a}| = 2$ ,  $|\vec{b}| = 5$  and  $|\vec{a} \times \vec{b}| = 8$ , then  $|\vec{a} \cdot \vec{b}|$  is equal to :

**Options :**

86435161939. 4

86435161940. 5

86435161941. 3

86435161942. 6

**Question Number : 79 Question Id : 86435118448 Question Type : MCQ Option Shuffling : Yes**

**Is Question Mandatory : No**

**Correct Marks : 4 Wrong Marks : 1**

Consider functions  $f: A \rightarrow B$  and  $g: B \rightarrow C$  ( $A, B, C \subseteq \mathbb{R}$ ) such that  $(g \circ f)^{-1}$  exists, then :

**Options :**

86435161943.  $f$  is one-one and  $g$  is onto

86435161944.  $f$  and  $g$  both are one-one

86435161945.  $f$  is onto and  $g$  is one-one

86435161946.  $f$  and  $g$  both are onto

**Question Number : 80 Question Id : 86435118449 Question Type : MCQ Option Shuffling : Yes**

**Is Question Mandatory : No**

**Correct Marks : 4 Wrong Marks : 1**

Let  $a$ ,  $b$  and  $c$  be distinct positive numbers. If the vectors  $a\hat{i} + a\hat{j} + c\hat{k}$ ,  $\hat{i} + \hat{k}$  and

$c\hat{i} + c\hat{j} + b\hat{k}$  are co-planar, then  $c$  is equal to :

**Options :**

86435161947.  $\frac{a + b}{2}$

86435161948.  $\sqrt{ab}$

86435161949.  $\frac{2}{\frac{1}{a} + \frac{1}{b}}$

86435161950.  $\frac{1}{a} + \frac{1}{b}$

## Mathematics Section B

<b>Section Id :</b>	864351799
<b>Section Number :</b>	6
<b>Section type :</b>	Online
<b>Mandatory or Optional :</b>	Mandatory
<b>Number of Questions :</b>	10
<b>Number of Questions to be attempted :</b>	5
<b>Section Marks :</b>	20
<b>Enable Mark as Answered Mark for Review and Clear Response :</b>	Yes
<b>Sub-Section Number :</b>	1
<b>Sub-Section Id :</b>	8643511026

Question Number : 81 Question Id : 86435118450 Question Type : SA

Correct Marks : 4 Wrong Marks : 0

The equation of a circle is  $\operatorname{Re}(z^2) + 2(\operatorname{Im}(z))^2 + 2\operatorname{Re}(z) = 0$ , where  $z = x + iy$ . A line which passes through the center of the given circle and the vertex of the parabola,  $x^2 - 6x - y + 13 = 0$ , has  $y$ -intercept equal to \_\_\_\_\_.

Response Type : Numeric

Evaluation Required For SA : Yes

Show Word Count : Yes

Answers Type : Equal

Text Areas : PlainText

Possible Answers :

1

Question Number : 82 Question Id : 86435118451 Question Type : SA

Correct Marks : 4 Wrong Marks : 0

If the lines  $\frac{x - k}{1} = \frac{y - 2}{2} = \frac{z - 3}{3}$  and  $\frac{x + 1}{3} = \frac{y + 2}{2} = \frac{z + 3}{1}$  are co-planar, then the value of  $k$  is \_\_\_\_\_.

Response Type : Numeric

Evaluation Required For SA : Yes

Show Word Count : Yes

Answers Type : Equal

Text Areas : PlainText

Possible Answers :

1

Question Number : 83 Question Id : 86435118452 Question Type : SA

Correct Marks : 4 Wrong Marks : 0

Let  $n \in \mathbb{N}$  and  $[x]$  denote the greatest integer less than or equal to  $x$ . If the sum of  $(n+1)$

terms  ${}^n C_0, 3 \cdot {}^n C_1, 5 \cdot {}^n C_2, 7 \cdot {}^n C_3, \dots$  is equal to  $2^{100} \cdot 101$ , then  $2 \left[ \frac{n-1}{2} \right]$  is equal to \_\_\_\_\_.

**Response Type :** Numeric

**Evaluation Required For SA :** Yes

**Show Word Count :** Yes

**Answers Type :** Equal

**Text Areas :** PlainText

**Possible Answers :**

1

**Question Number :** 84 **Question Id :** 86435118453 **Question Type :** SA

**Correct Marks :** 4 **Wrong Marks :** 0

If  $a+b+c=1$ ,  $ab+bc+ca=2$  and  $abc=3$ , then the value of  $a^4+b^4+c^4$  is equal to \_\_\_\_\_.

**Response Type :** Numeric

**Evaluation Required For SA :** Yes

**Show Word Count :** Yes

**Answers Type :** Equal

**Text Areas :** PlainText

**Possible Answers :**

1

**Question Number :** 85 **Question Id :** 86435118454 **Question Type :** SA

**Correct Marks :** 4 **Wrong Marks :** 0

A fair coin is tossed  $n$ -times such that the probability of getting at least one head is at least 0.9. Then the minimum value of  $n$  is \_\_\_\_\_.

**Response Type :** Numeric

**Evaluation Required For SA :** Yes

**Show Word Count :** Yes

Answers Type : Equal

Text Areas : PlainText

Possible Answers :

1

Question Number : 86 Question Id : 86435118455 Question Type : SA

Correct Marks : 4 Wrong Marks : 0

Let a curve  $y = f(x)$  pass through the point  $(2, (\log_e 2)^2)$  and have slope  $\frac{2y}{x \log_e x}$  for all positive real value of  $x$ . Then the value of  $f(e)$  is equal to \_\_\_\_\_.

Response Type : Numeric

Evaluation Required For SA : Yes

Show Word Count : Yes

Answers Type : Equal

Text Areas : PlainText

Possible Answers :

1

Question Number : 87 Question Id : 86435118456 Question Type : SA

Correct Marks : 4 Wrong Marks : 0

If the co-efficients of  $x^7$  and  $x^8$  in the expansion of  $\left(2 + \frac{x}{3}\right)^n$  are equal, then the value of  $n$  is equal to \_\_\_\_\_.

Response Type : Numeric

Evaluation Required For SA : Yes

Show Word Count : Yes

Answers Type : Equal

Text Areas : PlainText

Possible Answers :

**Question Number : 88 Question Id : 86435118457 Question Type : SA**

**Correct Marks : 4 Wrong Marks : 0**

If  $(\vec{a} + 3\vec{b})$  is perpendicular to  $(7\vec{a} - 5\vec{b})$  and  $(\vec{a} - 4\vec{b})$  is perpendicular to  $(7\vec{a} - 2\vec{b})$ ,  
then the angle between  $\vec{a}$  and  $\vec{b}$  (in degrees) is \_\_\_\_\_.

**Response Type : Numeric**

**Evaluation Required For SA : Yes**

**Show Word Count : Yes**

**Answers Type : Equal**

**Text Areas : PlainText**

**Possible Answers :**

1

**Question Number : 89 Question Id : 86435118458 Question Type : SA**

**Correct Marks : 4 Wrong Marks : 0**

If a rectangle is inscribed in an equilateral triangle of side length  $2\sqrt{2}$  as shown in the figure,  
then the square of the largest area of such a rectangle is \_\_\_\_\_.

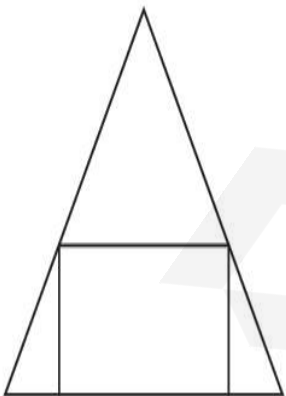

**Response Type : Numeric**

**Evaluation Required For SA : Yes**

**Show Word Count : Yes**

**Answers Type : Equal**

**Text Areas :** PlainText

**Possible Answers :**

1

**Question Number : 90 Question Id : 86435118459 Question Type : SA**

**Correct Marks : 4 Wrong Marks : 0**

Consider the function  $f(x) = \frac{P(x)}{\sin(x-2)}$ ,  $x \neq 2$   
 $= 7$ ,  $x = 2$

where  $P(x)$  is a polynomial such that  $P''(x)$  is always a constant and  $P(3) = 9$ . If  $f(x)$  is continuous at  $x = 2$ , then  $P(5)$  is equal to \_\_\_\_\_.

**Response Type :** Numeric

**Evaluation Required For SA :** Yes

**Show Word Count :** Yes

**Answers Type :** Equal

**Text Areas :** PlainText

**Possible Answers :**

1