

# National Testing Agency

<b>Question Paper Name :</b>	B Tech 31st Aug 2021 Shift 2
<b>Subject Name :</b>	B TECH
<b>Creation Date :</b>	2021-09-01 10:09:32
<b>Duration :</b>	180
<b>Total Marks :</b>	300
<b>Display Marks:</b>	Yes

## B TECH

<b>Group Number :</b>	1
<b>Group Id :</b>	864351258
<b>Group Maximum Duration :</b>	0
<b>Group Minimum Duration :</b>	180
<b>Show Attended Group? :</b>	No
<b>Edit Attended Group? :</b>	No
<b>Break time :</b>	0
<b>Group Marks :</b>	300
<b>Is this Group for Examiner? :</b>	No

## Physics Section A

<b>Section Id :</b>	864351986
<b>Section Number :</b>	1
<b>Section type :</b>	Online
<b>Mandatory or Optional :</b>	Mandatory
<b>Number of Questions :</b>	20
<b>Number of Questions to be attempted :</b>	20
<b>Section Marks :</b>	80

Enable Mark as Answered Mark for Review and Clear Response : Yes  
Sub-Section Number : 1  
Sub-Section Id : 8643511213  
Question Shuffling Allowed : Yes

Question Number : 1 Question Id : 86435121250 Question Type : MCQ Option Shuffling : Yes Is Question Mandatory : No  
Correct Marks : 4 Wrong Marks : 1

If velocity [V] time [T] and force [F] are chosen as the base quantities, the dimensions of the mass will be :

Options :

86435170331.  $[FT^{-1}V^{-1}]$

86435170332.  $[FVT^{-1}]$

86435170333.  $[FT^2V]$

86435170334.  $[FTV^{-1}]$

Question Number : 2 Question Id : 86435121251 Question Type : MCQ Option Shuffling : Yes Is Question Mandatory : No  
Correct Marks : 4 Wrong Marks : 1

A free electron of 2.6 eV energy collides with a  $H^+$  ion. This results in the formation of a hydrogen atom in the first excited state and a photon is released. Find the frequency of the emitted photon. ( $h = 6.6 \times 10^{-34} \text{ J s}$ )

Options :

86435170335.  $0.19 \times 10^{15} \text{ MHz}$

86435170336.  $9.0 \times 10^{27}$  MHz

86435170337.  $1.45 \times 10^9$  MHz

86435170338.  $1.45 \times 10^{16}$  MHz

**Question Number : 3 Question Id : 86435121252 Question Type : MCQ Option Shuffling : Yes Is Question Mandatory : No Correct Marks : 4 Wrong Marks : 1**

**Statement I :**

If three forces  $\vec{F}_1$ ,  $\vec{F}_2$  and  $\vec{F}_3$  are represented by three sides of a triangle and  $\vec{F}_1 + \vec{F}_2 = -\vec{F}_3$ , then these three forces are concurrent forces and satisfy the condition for equilibrium.

**Statement II :**

A triangle made up of three forces  $\vec{F}_1$ ,  $\vec{F}_2$  and  $\vec{F}_3$  as its sides taken in the same order, satisfy the condition for translatory equilibrium.

In the light of the above statements, choose the **most appropriate** answer from the options given below :

**Options :**

86435170339. Both **Statement I** and **Statement II** are true.

86435170340. Both **Statement I** and **Statement II** are false.

86435170341. **Statement I** is true but **Statement II** is false.

86435170342. **Statement I** is false but **Statement II** is true.

**Question Number : 4 Question Id : 86435121253 Question Type : MCQ Option Shuffling : Yes Is Question Mandatory : No**

**Correct Marks : 4 Wrong Marks : 1**

Two thin metallic spherical shells of radii  $r_1$  and  $r_2$  ( $r_1 < r_2$ ) are placed with their centres coinciding. A material of thermal conductivity  $K$  is filled in the space between the shells. The inner shell is maintained at temperature  $\theta_1$  and the outer shell at temperature  $\theta_2$  ( $\theta_1 < \theta_2$ ). The rate at which heat flows radially through the material is :

**Options :**

86435170343. 
$$\frac{4\pi K r_1 r_2 (\theta_2 - \theta_1)}{r_2 - r_1}$$

86435170344. 
$$\frac{K(\theta_2 - \theta_1) (r_2 - r_1)}{4\pi r_1 r_2}$$

86435170345. 
$$\frac{K(\theta_2 - \theta_1)}{r_2 - r_1}$$

86435170346. 
$$\frac{\pi r_1 r_2 (\theta_2 - \theta_1)}{r_2 - r_1}$$

**Question Number : 5 Question Id : 86435121254 Question Type : MCQ Option Shuffling : Yes Is Question Mandatory : No**

**Correct Marks : 4 Wrong Marks : 1**

**Statement I :**

Two forces  $(\vec{P} + \vec{Q})$  and  $(\vec{P} - \vec{Q})$  where  $\vec{P} \perp \vec{Q}$ , when act at an angle  $\theta_1$  to each other, the magnitude of their resultant is  $\sqrt{3(P^2 + Q^2)}$ , when they act at an angle  $\theta_2$ , the magnitude of their resultant becomes  $\sqrt{2(P^2 + Q^2)}$ . This is possible only when  $\theta_1 < \theta_2$ .

**Statement II :**

In the situation given above.

$$\theta_1 = 60^\circ \text{ and } \theta_2 = 90^\circ$$

In the light of the above statements, choose the **most appropriate** answer from the options given below :

**Options :**

86435170347. Both **Statement I** and **Statement II** are true.

86435170348. Both **Statement I** and **Statement II** are false.

86435170349. **Statement I** is true but **Statement II** is false.

86435170350. **Statement I** is false but **Statement II** is true.

**Question Number : 6 Question Id : 86435121255 Question Type : MCQ Option Shuffling : Yes Is Question Mandatory : No Correct Marks : 4 Wrong Marks : 1**

If  $R_E$  be the radius of Earth, then the ratio between the acceleration due to gravity at a depth 'r' below and a height 'r' above the earth surface is :

(Given :  $r < R_E$ )

Options :

86435170351.  $1 + \frac{r}{R_E} + \frac{r^2}{R_E^2} + \frac{r^3}{R_E^3}$

86435170352.  $1 + \frac{r}{R_E} - \frac{r^2}{R_E^2} - \frac{r^3}{R_E^3}$

86435170353.  $1 - \frac{r}{R_E} - \frac{r^2}{R_E^2} - \frac{r^3}{R_E^3}$

86435170354.  $1 + \frac{r}{R_E} - \frac{r^2}{R_E^2} + \frac{r^3}{R_E^3}$

Question Number : 7 Question Id : 86435121256 Question Type : MCQ Option Shuffling : Yes Is Question Mandatory : No

Correct Marks : 4 Wrong Marks : 1

A mixture of hydrogen and oxygen has volume  $500 \text{ cm}^3$ , temperature  $300 \text{ K}$ , pressure  $400 \text{ kPa}$  and mass  $0.76 \text{ g}$ . The ratio of masses of oxygen to hydrogen will be :

Options :

86435170355. 3 : 8

86435170356. 8 : 3

86435170357. 3 : 16

86435170358. 16 : 3

**Question Number : 8 Question Id : 86435121257 Question Type : MCQ Option Shuffling : Yes Is Question Mandatory : No Correct Marks : 4 Wrong Marks : 1**

A block moving horizontally on a smooth surface with a speed of 40 m/s splits into two parts with masses in the ratio of 1 : 2. If the smaller part moves at 60 m/s in the same direction, then the fractional change in kinetic energy is :

**Options :**

86435170359.  $\frac{1}{8}$

86435170360.  $\frac{1}{4}$

86435170361.  $\frac{1}{3}$

86435170362.  $\frac{2}{3}$

Question Number : 9 Question Id : 86435121258 Question Type : MCQ Option Shuffling : Yes Is Question Mandatory : No  
 Correct Marks : 4 Wrong Marks : 1

The equivalent resistance of the given circuit between the terminals A and B is :

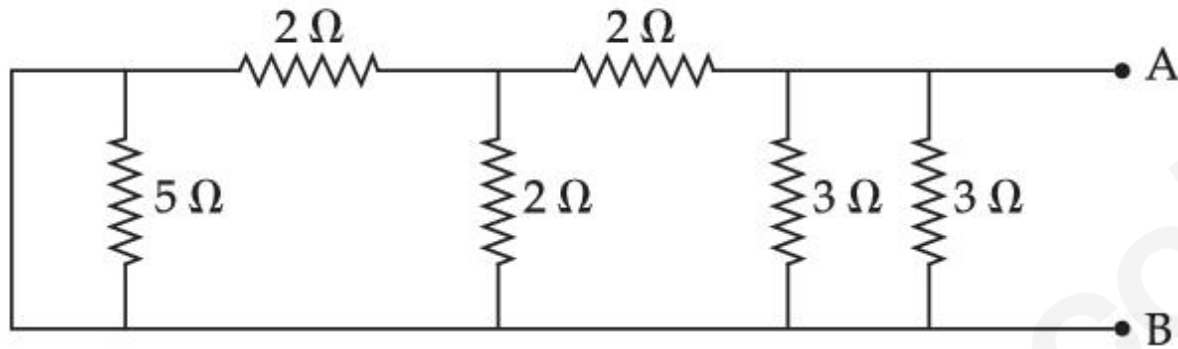

Options :

86435170363.  $0\ \Omega$

86435170364.  $3\ \Omega$

86435170365.  $1\ \Omega$

86435170366.  $\frac{9}{2}\ \Omega$

Question Number : 10 Question Id : 86435121259 Question Type : MCQ Option Shuffling : Yes Is Question Mandatory : No  
 Correct Marks : 4 Wrong Marks : 1

A bob of mass 'm' suspended by a thread of length  $l$  undergoes simple harmonic oscillations with time period  $T$ . If the bob is immersed in a liquid that has density  $\frac{1}{4}$  times that of the bob and the length of the thread is increased by  $1/3^{\text{rd}}$  of the original length, then the time period of the simple harmonic oscillations will be :

Options :

86435170367.  $\frac{4}{3} T$

86435170368.  $\frac{3}{4} T$

86435170369.  $\frac{3}{2} T$

86435170370.  $T$

Question Number : 11 Question Id : 86435121260 Question Type : MCQ Option Shuffling : Yes Is Question Mandatory : No  
Correct Marks : 4 Wrong Marks : 1

Four identical hollow cylindrical columns of mild steel support a big structure of mass  $50 \times 10^3$  kg. The inner and outer radii of each column are 50 cm and 100 cm respectively. Assuming uniform local distribution, calculate the compression strain of each column.

[use  $Y = 2.0 \times 10^{11}$  Pa,  $g = 9.8$  m/s<sup>2</sup>]

Options :

86435170371.  $2.60 \times 10^{-7}$

86435170372.  $3.60 \times 10^{-8}$

86435170373.  $1.87 \times 10^{-3}$

86435170374.  $7.07 \times 10^{-4}$

Question Number : 12 Question Id : 86435121261 Question Type : MCQ Option Shuffling : Yes Is Question Mandatory : No

Correct Marks : 4 Wrong Marks : 1

For a body executing S.H.M. :

- (a) Potential energy is always equal to its K.E.
- (b) Average potential and kinetic energy over any given time interval are always equal.
- (c) Sum of the kinetic and potential energy at any point of time is constant.
- (d) Average K.E. in one time period is equal to average potential energy in one time period.

Choose the **most appropriate** option from the options given below :

Options :

86435170375. only (b)

86435170376. (b) and (c)

86435170377. only (c)

86435170378. (c) and (d)

**Question Number : 13 Question Id : 86435121262 Question Type : MCQ Option Shuffling : Yes Is Question Mandatory : No Correct Marks : 4 Wrong Marks : 1**

The magnetic field vector of an electromagnetic wave is given by  $B = B_0 \frac{\hat{i} + \hat{j}}{\sqrt{2}} \cos(kz - \omega t)$ ;

where  $\hat{i}, \hat{j}$  represents unit vector along  $x$  and  $y$ -axis respectively. At  $t=0$  s, two electric

charges  $q_1$  of  $4\pi$  coulomb and  $q_2$  of  $2\pi$  coulomb located at  $\left(0, 0, \frac{\pi}{k}\right)$  and  $\left(0, 0, \frac{3\pi}{k}\right)$ ,

respectively, have the same velocity of  $0.5c \hat{i}$ , (where  $c$  is the velocity of light). The ratio of

the force acting on charge  $q_1$  to  $q_2$  is :

**Options :**

86435170379.  $\sqrt{2} : 1$

86435170380.  $1 : \sqrt{2}$

86435170381.  $2 : 1$

86435170382.  $2\sqrt{2} : 1$

**Question Number : 14 Question Id : 86435121263 Question Type : MCQ Option Shuffling : Yes Is Question Mandatory : No Correct Marks : 4 Wrong Marks : 1**

A system consists of two identical spheres each of mass 1.5 kg and radius 50 cm at the ends of a light rod. The distance between the centres of the two spheres is 5 m. What will be the moment of inertia of the system about an axis perpendicular to the rod passing through its midpoint ?

**Options :**

86435170383.  $19.05 \text{ kgm}^2$

86435170384.  $1.905 \times 10^5 \text{ kgm}^2$

86435170385.  $18.75 \text{ kgm}^2$

86435170386.  $1.875 \times 10^5 \text{ kgm}^2$

**Question Number : 15 Question Id : 86435121264 Question Type : MCQ Option Shuffling : Yes Is Question Mandatory : No Correct Marks : 4 Wrong Marks : 1**

A coil is placed in a magnetic field  $\vec{B}$  as shown below :

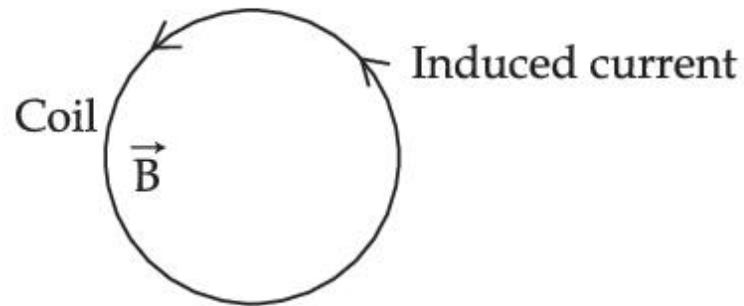

A current is induced in the coil because  $\vec{B}$  is :

Options :

- 86435170387. outward and increasing with time
- 86435170388. outward and decreasing with time
- 86435170389. parallel to the plane of coil and increasing with time
- 86435170390. parallel to the plane of coil and decreasing with time

Question Number : 16 Question Id : 86435121265 Question Type : MCQ Option Shuffling : Yes Is Question Mandatory : No  
 Correct Marks : 4 Wrong Marks : 1

If  $V_A$  and  $V_B$  are the input voltages (either 5 V or 0 V) and  $V_o$  is the output voltage then the two gates represented in the following circuits (A) and (B) are :

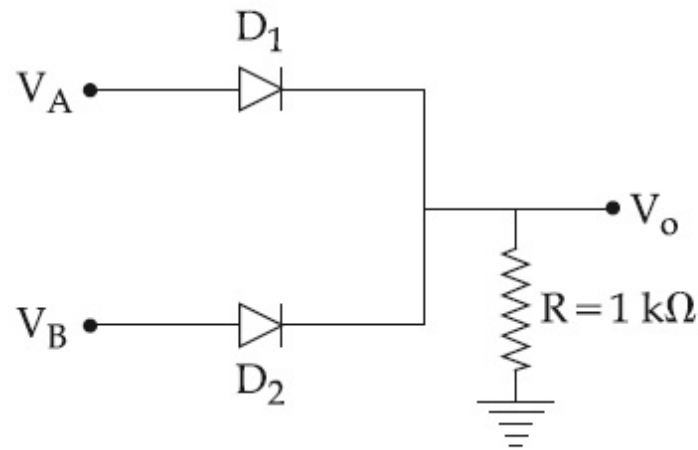

(A)

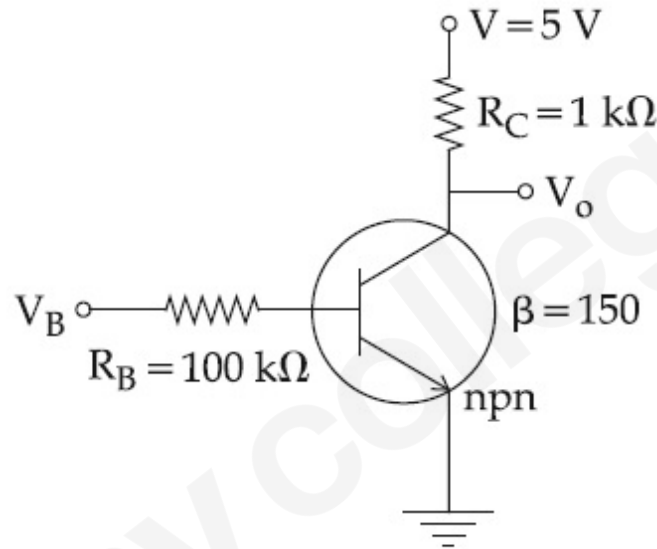

(B)

Options :

- 86435170391. NAND and NOR Gate
- 86435170392. AND and OR Gate
- 86435170393. AND and NOT Gate
- 86435170394. OR and NOT Gate

Question Number : 17 Question Id : 86435121266 Question Type : MCQ Option Shuffling : Yes Is Question Mandatory : No Correct Marks : 4 Wrong Marks : 1

A current of 1.5 A is flowing through a triangle, of side 9 cm each. The magnetic field at the centroid of the triangle is :

(Assume that the current is flowing in the clockwise direction.)

Options :

86435170395.  $3 \times 10^{-5}$  T, inside the plane of triangle

86435170396.  $3 \times 10^{-7}$  T, outside the plane of triangle

86435170397.  $2\sqrt{3} \times 10^{-5}$  T, inside the plane of triangle

86435170398.  $2\sqrt{3} \times 10^{-7}$  T, outside the plane of triangle

Question Number : 18 Question Id : 86435121267 Question Type : MCQ Option Shuffling : Yes Is Question Mandatory : No

Correct Marks : 4 Wrong Marks : 1

**Statement I :**

To get a steady dc output from the pulsating voltage received from a full wave rectifier we can connect a capacitor across the output parallel to the load  $R_L$ .

**Statement II :**

To get a steady dc output from the pulsating voltage received from a full wave rectifier we can connect an inductor in series with  $R_L$ .

In the light of the above statements, choose the **most appropriate** answer from the options given below :

Options :

86435170399. Both **Statement I** and **Statement II** are true

86435170400. Both **Statement I** and **Statement II** are false

86435170401. **Statement I** is true but **Statement II** is false

86435170402. **Statement I** is false but **Statement II** is true

Question Number : 19 Question Id : 86435121268 Question Type : MCQ Option Shuffling : Yes Is Question Mandatory : No

Correct Marks : 4 Wrong Marks : 1

Consider two separate ideal gases of electrons and protons having same number of particles. The temperature of both the gases are same. The ratio of the uncertainty in determining the position of an electron to that of a proton is proportional to :

Options :

86435170403.  $\sqrt{\frac{m_e}{m_p}}$

86435170404.  $\frac{m_p}{m_e}$

86435170405.  $\sqrt{\frac{m_p}{m_e}}$

$$\left(\frac{m_p}{m_e}\right)^{3/2}$$

86435170406.

Question Number : 20 Question Id : 86435121269 Question Type : MCQ Option Shuffling : Yes Is Question Mandatory : No  
 Correct Marks : 4 Wrong Marks : 1

Choose the **incorrect** statement :

- (a) The electric lines of force entering into a Gaussian surface provide negative flux.
- (b) A charge 'q' is placed at the centre of a cube. The flux through all the faces will be the same.
- (c) In a uniform electric field net flux through a closed Gaussian surface containing no net charge, is zero.
- (d) When electric field is parallel to a Gaussian surface, it provides a finite non-zero flux.

Choose the **most appropriate** answer from the options given below :

Options :

86435170407. (a) and (c) Only

86435170408. (b) and (d) Only

86435170409. (c) and (d) Only

86435170410. (d) Only

## Physics Section B

<b>Section Id :</b>	864351987
<b>Section Number :</b>	2
<b>Section type :</b>	Online
<b>Mandatory or Optional :</b>	Mandatory
<b>Number of Questions :</b>	10
<b>Number of Questions to be attempted :</b>	5
<b>Section Marks :</b>	20
<b>Enable Mark as Answered Mark for Review and Clear Response :</b>	Yes
<b>Sub-Section Number :</b>	1
<b>Sub-Section Id :</b>	8643511214
<b>Question Shuffling Allowed :</b>	Yes

**Question Number : 21 Question Id : 86435121270 Question Type : SA**  
**Correct Marks : 4 Wrong Marks : 0**

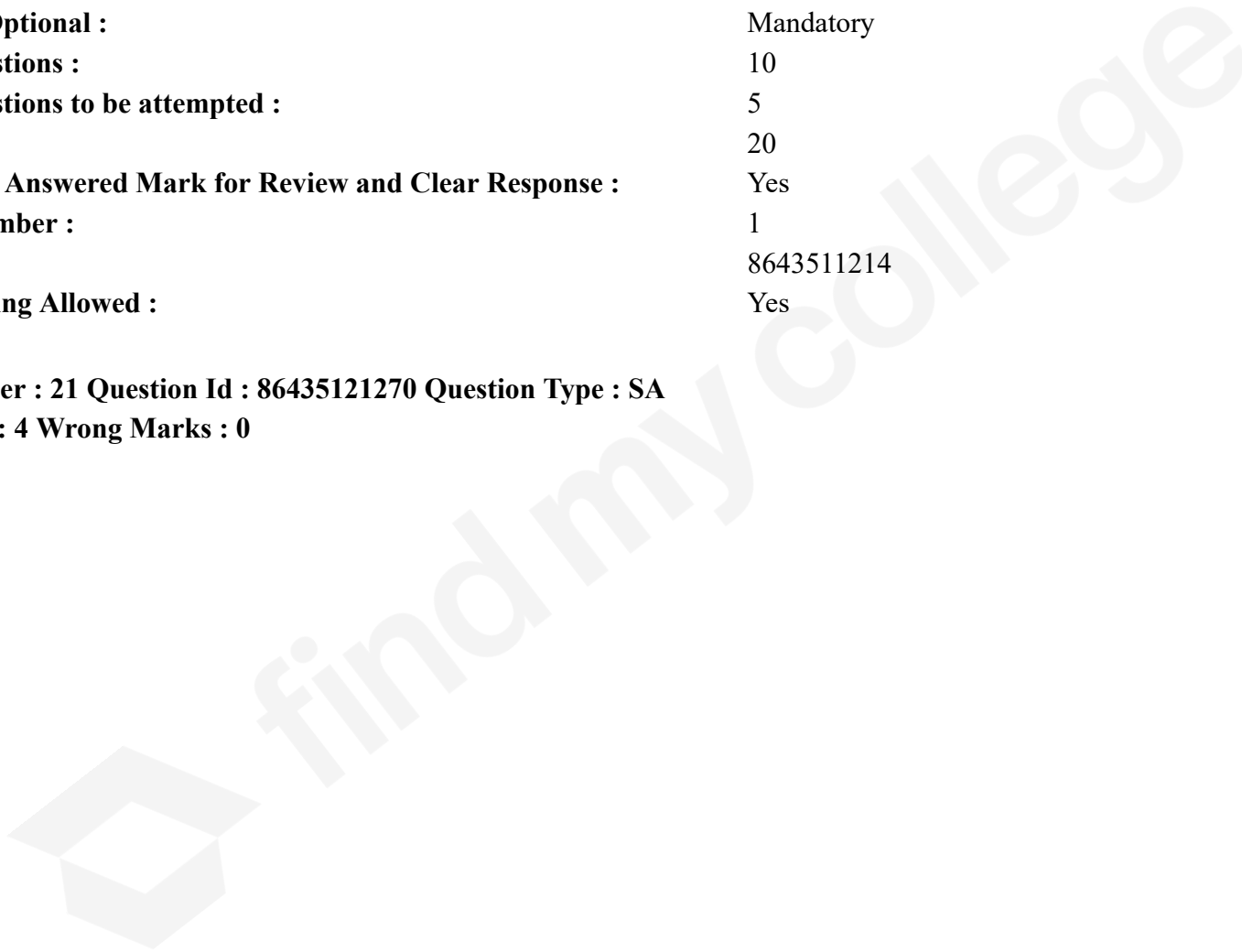

Cross-section view of a prism is the equilateral triangle ABC shown in the figure. The minimum deviation is observed using this prism when the angle of incidence is equal to the prism angle. The time taken by light to travel from P (midpoint of BC) to A is \_\_\_\_\_  $\times 10^{-10}$  s. (Given, speed of light in vacuum =  $3 \times 10^8$  m/s and  $\cos 30^\circ = \frac{\sqrt{3}}{2}$ )

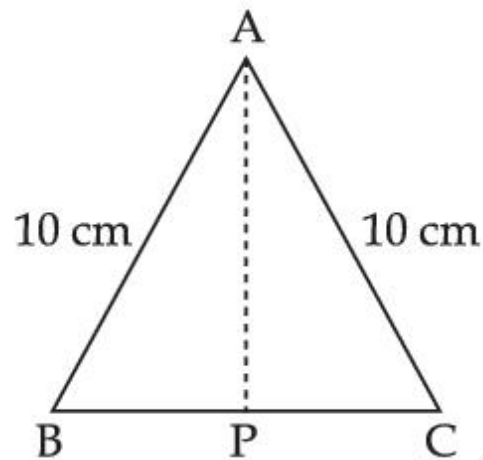

**Response Type :** Numeric

**Evaluation Required For SA :** Yes

**Show Word Count :** Yes

**Answers Type :** Equal

**Text Areas :** PlainText

**Possible Answers :**

1

**Question Number :** 22 **Question Id :** 86435121271 **Question Type :** SA

**Correct Marks :** 4 **Wrong Marks :** 0

A sample of gas with  $\gamma = 1.5$  is taken through an adiabatic process in which the volume is compressed from  $1200 \text{ cm}^3$  to  $300 \text{ cm}^3$ . If the initial pressure is  $200 \text{ kPa}$ . The absolute value of the workdone by the gas in the process = \_\_\_\_\_ J.

**Response Type :** Numeric

**Evaluation Required For SA :** Yes

**Show Word Count :** Yes

**Answers Type :** Equal

**Text Areas :** PlainText

**Possible Answers :**

1

**Question Number :** 23 **Question Id :** 86435121272 **Question Type :** SA

**Correct Marks :** 4 **Wrong Marks :** 0

A parallel plate capacitor of capacitance  $200 \mu\text{F}$  is connected to a battery of  $200 \text{ V}$ . A dielectric slab of dielectric constant 2 is now inserted into the space between plates of capacitor while the battery remain connected. The change in the electrostatic energy in the capacitor will be \_\_\_\_\_ J.

**Response Type :** Numeric

**Evaluation Required For SA :** Yes

**Show Word Count :** Yes

**Answers Type :** Equal

**Text Areas :** PlainText

**Possible Answers :**

1

**Question Number :** 24 **Question Id :** 86435121273 **Question Type :** SA

**Correct Marks :** 4 **Wrong Marks :** 0

In a Young's double slit experiment, the slits are separated by 0.3 mm and the screen is 1.5 m away from the plane of slits. Distance between fourth bright fringes on both sides of central bright fringe is 2.4 cm. The frequency of light used is \_\_\_\_\_  $\times 10^{14}$  Hz.

**Response Type :** Numeric

**Evaluation Required For SA :** Yes

**Show Word Count :** Yes

**Answers Type :** Equal

**Text Areas :** PlainText

**Possible Answers :**

1

**Question Number :** 25 **Question Id :** 86435121274 **Question Type :** SA

**Correct Marks :** 4 **Wrong Marks :** 0

A bandwidth of 6 MHz is available for A.M. transmission. If the maximum audio signal frequency used for modulating the carrier wave is not to exceed 6 kHz. The number of stations that can be broadcasted within this band simultaneously without interfering with each other will be \_\_\_\_\_.

**Response Type :** Numeric

**Evaluation Required For SA :** Yes

**Show Word Count :** Yes

**Answers Type :** Equal

**Text Areas :** PlainText

**Possible Answers :**

1

**Question Number :** 26 **Question Id :** 86435121275 **Question Type :** SA

**Correct Marks :** 4 **Wrong Marks :** 0

The diameter of a spherical bob is measured using a vernier callipers. 9 divisions of the main scale, in the vernier callipers, are equal to 10 divisions of vernier scale. One main scale division is 1 mm. The main scale reading is 10 mm and 8<sup>th</sup> division of vernier scale was found to coincide exactly with one of the main scale division. If the given vernier callipers has positive zero error of 0.04 cm, then the radius of the bob is \_\_\_\_\_  $\times 10^{-2}$  cm.

**Response Type :** Numeric

**Evaluation Required For SA :** Yes

**Show Word Count :** Yes

**Answers Type :** Equal

**Text Areas :** PlainText

**Possible Answers :**

1

**Question Number :** 27 **Question Id :** 86435121276 **Question Type :** SA

**Correct Marks :** 4 **Wrong Marks :** 0

A particle is moving with constant acceleration 'a'. Following graph shows  $v^2$  versus  $x$ (displacement) plot. The acceleration of the particle is \_\_\_\_\_  $\text{m/s}^2$ .

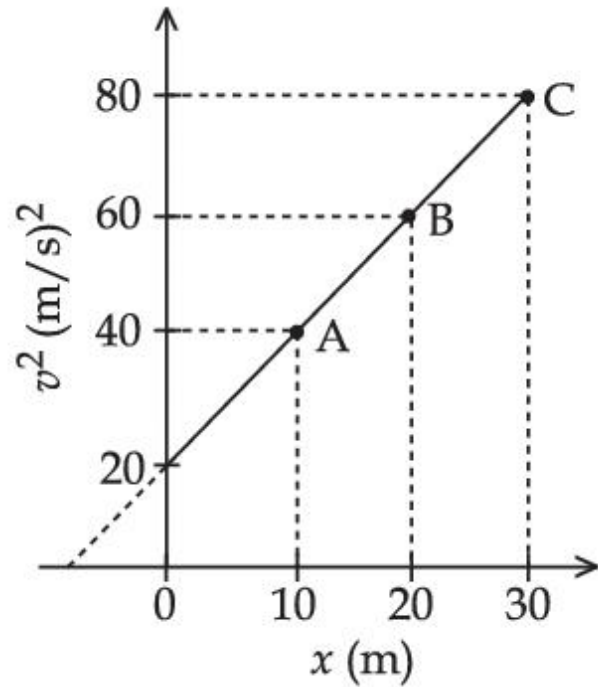

Response Type : Numeric

Evaluation Required For SA : Yes

Show Word Count : Yes

Answers Type : Equal

Text Areas : PlainText

Possible Answers :

1

Question Number : 28 Question Id : 86435121277 Question Type : SA

Correct Marks : 4 Wrong Marks : 0

At very high frequencies, the effective impedance of the given circuit will be \_\_\_\_\_  $\Omega$ .

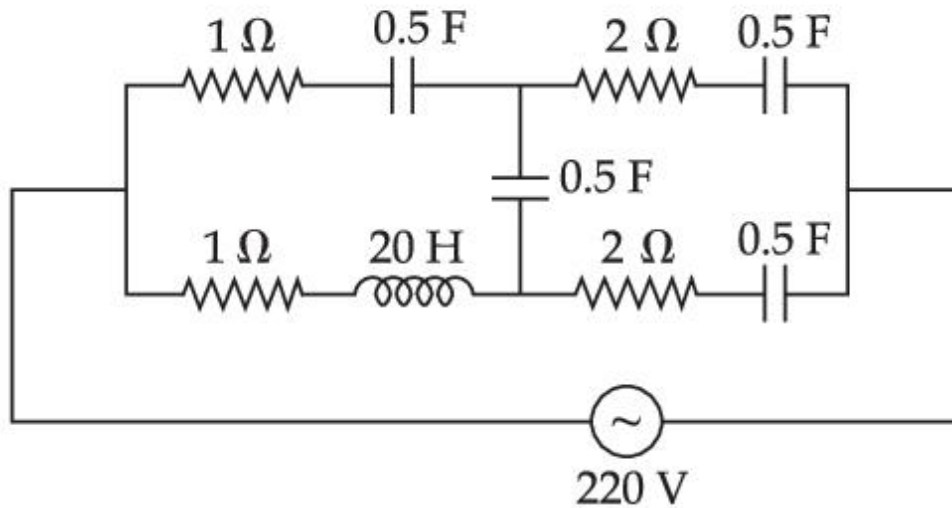

**Response Type :** Numeric

**Evaluation Required For SA :** Yes

**Show Word Count :** Yes

**Answers Type :** Equal

**Text Areas :** PlainText

**Possible Answers :**

1

**Question Number :** 29 **Question Id :** 86435121278 **Question Type :** SA

**Correct Marks :** 4 **Wrong Marks :** 0

A long solenoid with 1000 turns/m has a core material with relative permeability 500 and volume  $10^3 \text{ cm}^3$ . If the core material is replaced by another material having relative permeability of 750 with same volume maintaining same current of 0.75 A in the solenoid, the fractional change in the magnetic moment of the core would be approximately  $\left(\frac{x}{499}\right)$ .

Find the value of  $x$ .

**Response Type :** Numeric

**Evaluation Required For SA :** Yes

**Show Word Count :** Yes

**Answers Type :** Equal

**Text Areas :** PlainText

**Possible Answers :**

1

**Question Number :** 30 **Question Id :** 86435121279 **Question Type :** SA

**Correct Marks :** 4 **Wrong Marks :** 0

A resistor dissipates 192 J of energy in 1 s when a current of 4 A is passed through it. Now, when the current is doubled, the amount of thermal energy dissipated in 5 s is \_\_\_\_\_ J.

**Response Type :** Numeric

**Evaluation Required For SA :** Yes

**Show Word Count :** Yes

**Answers Type :** Equal

**Text Areas :** PlainText

**Possible Answers :**

1

## Chemistry Section A

Section Id :	864351988
Section Number :	3
Section type :	Online
Mandatory or Optional :	Mandatory
Number of Questions :	20
Number of Questions to be attempted :	20
Section Marks :	80
Enable Mark as Answered Mark for Review and Clear Response :	Yes
Sub-Section Number :	1
Sub-Section Id :	8643511215
Question Shuffling Allowed :	Yes

Question Number : 31 Question Id : 86435121280 Question Type : MCQ Option Shuffling : Yes Is Question Mandatory : No  
 Correct Marks : 4 Wrong Marks : 1

The **incorrect** expression among the following is :

Options :

86435170421. 
$$\frac{\Delta G_{\text{System}}}{\Delta S_{\text{Total}}} = - T \text{ (at constant P)}$$

86435170422. For isothermal process  $w_{\text{reversible}} = - nRT \ln \frac{V_f}{V_i}$

86435170423. 
$$\ln K = \frac{\Delta H^\circ - T\Delta S^\circ}{RT}$$

86435170424. 
$$K = e^{-\Delta G^\circ/RT}$$

Question Number : 32 Question Id : 86435121281 Question Type : MCQ Option Shuffling : Yes Is Question Mandatory : No  
Correct Marks : 4 Wrong Marks : 1

Match List - I with List - II :

List - I (Parameter)	List - II (Unit)
(a) Cell constant	(i) $\text{S cm}^2 \text{ mol}^{-1}$
(b) Molar conductivity	(ii) Dimensionless
(c) Conductivity	(iii) $\text{m}^{-1}$
(d) Degree of dissociation of electrolyte	(iv) $\Omega^{-1} \text{m}^{-1}$

Choose the **most appropriate** answer from the options given below :

Options :

86435170425. (a)-(ii), (b)-(i), (c)-(iii), (d)-(iv)

86435170426. (a)-(iii), (b)-(i), (c)-(iv), (d)-(ii)

86435170427. (a)-(i), (b)-(iv), (c)-(iii), (d)-(ii)

86435170428. (a)-(iii), (b)-(i), (c)-(ii), (d)-(iv)

Question Number : 33 Question Id : 86435121282 Question Type : MCQ Option Shuffling : Yes Is Question Mandatory : No  
Correct Marks : 4 Wrong Marks : 1

Which one of the following correctly represents the order of stability of oxides,  $X_2O$ ; (X = halogen) ?

Options :

86435170429. I > Cl > Br

86435170430. Cl > I > Br

86435170431. Br > Cl > I

86435170432. Br > I > Cl

Question Number : 34 Question Id : 86435121283 Question Type : MCQ Option Shuffling : Yes Is Question Mandatory : No

Correct Marks : 4 Wrong Marks : 1

Which one of the following statements is **incorrect** ?

Options :

86435170433.

Bond dissociation enthalpy of  $H_2$  is highest among diatomic gaseous molecules which contain a single bond.

86435170434. At around 2000 K, the dissociation of dihydrogen into its atoms is nearly 8.1%.

86435170435. Dihydrogen is produced on reacting zinc with HCl as well as  $NaOH_{(aq)}$ .

86435170436.

Atomic hydrogen is produced when  $H_2$  molecules at a high temperature are irradiated with UV radiation.

Question Number : 35 Question Id : 86435121284 Question Type : MCQ Option Shuffling : Yes Is Question Mandatory : No  
Correct Marks : 4 Wrong Marks : 1

Given below are two statements : one is labelled as **Assertion (A)** and the other is labelled as **Reason (R)**.

**Assertion (A)** : Lithium salts are hydrated.

**Reason (R)** : Lithium has higher polarising power than other alkali metal group members.

In the light of the above statements, choose the **most appropriate** answer from the options given below :

Options :

86435170437. Both **(A)** and **(R)** are correct and **(R)** is the correct explanation of **(A)**.

86435170438. Both **(A)** and **(R)** are correct but **(R)** is NOT the correct explanation of **(A)**.

86435170439. **(A)** is correct but **(R)** is not correct.

86435170440. **(A)** is not correct but **(R)** is correct.

Question Number : 36 Question Id : 86435121285 Question Type : MCQ Option Shuffling : Yes Is Question Mandatory : No  
Correct Marks : 4 Wrong Marks : 1

The number of  $S=O$  bonds present in sulphurous acid, peroxodisulphuric acid and pyrosulphuric acid, respectively are :

Options :

86435170441. 2, 4 and 3

86435170442. 1, 4 and 4

86435170443. 1, 4 and 3

86435170444. 2, 3 and 4

Question Number : 37 Question Id : 86435121286 Question Type : MCQ Option Shuffling : Yes Is Question Mandatory : No  
Correct Marks : 4 Wrong Marks : 1

The  $\text{Eu}^{2+}$  ion is a strong reducing agent in spite of its ground state electronic configuration (outermost) : [Atomic number of Eu = 63]

Options :

86435170445.  $4f^7$

86435170446.  $4f^6$

86435170447.  $4f^7 6s^2$

86435170448.  $4f^6 6s^2$

Question Number : 38 Question Id : 86435121287 Question Type : MCQ Option Shuffling : Yes Is Question Mandatory : No

Correct Marks : 4 Wrong Marks : 1

In which one of the following sets all species show disproportionation reaction ?

Options :

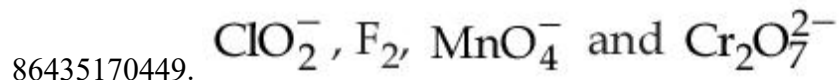

Question Number : 39 Question Id : 86435121288 Question Type : MCQ Option Shuffling : Yes Is Question Mandatory : No

Correct Marks : 4 Wrong Marks : 1

Spin only magnetic moment in BM of  $[\text{Fe}(\text{CO})_4(\text{C}_2\text{O}_4)]^+$  is :

Options :

86435170453. 1

86435170454. 1.73

86435170455. 5.92

86435170456. 0

Question Number : 40 Question Id : 86435121289 Question Type : MCQ Option Shuffling : Yes Is Question Mandatory : No

Correct Marks : 4 Wrong Marks : 1

The deposition of X and Y on ground surfaces is referred as wet and dry depositions, respectively. X and Y are :

Options :

86435170457. X = Ammonium salts , Y = SO<sub>2</sub>

86435170458. X = CO<sub>2</sub> , Y = SO<sub>2</sub>

86435170459. X = SO<sub>2</sub> , Y = Ammonium salts

86435170460. X = Ammonium salts , Y = CO<sub>2</sub>

Question Number : 41 Question Id : 86435121290 Question Type : MCQ Option Shuffling : Yes Is Question Mandatory : No

Correct Marks : 4 Wrong Marks : 1

The major product of the following reaction is :

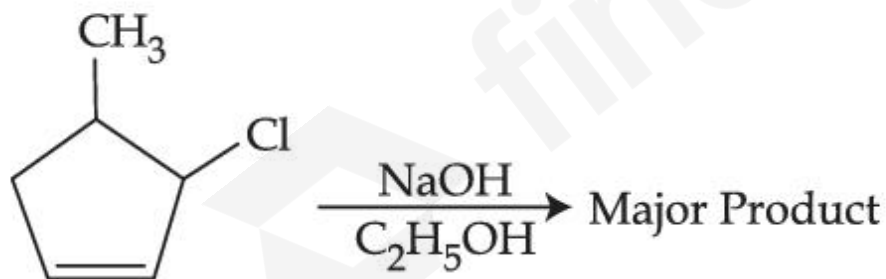

Options :

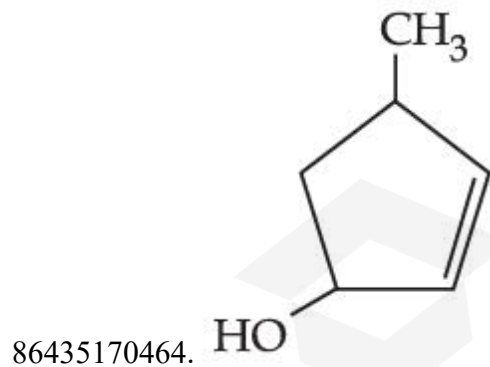
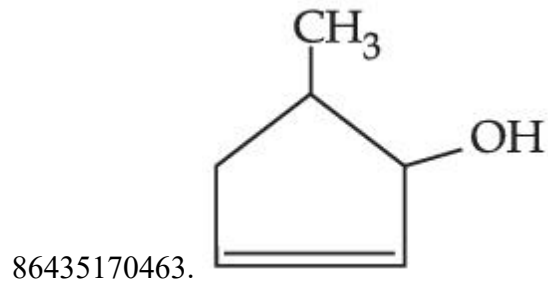
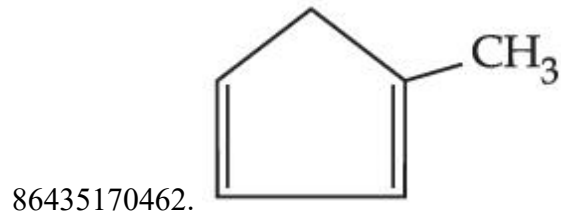
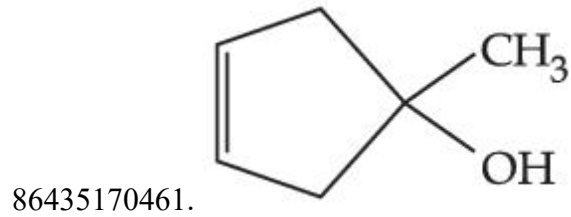

Question Number : 42 Question Id : 86435121291 Question Type : MCQ Option Shuffling : Yes Is Question Mandatory : No  
Correct Marks : 4 Wrong Marks : 1

Arrange the following conformational isomers of n-butane in order of their increasing potential energy :

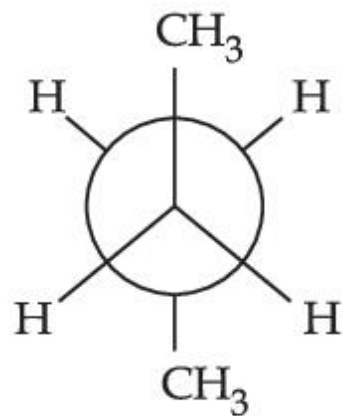

I

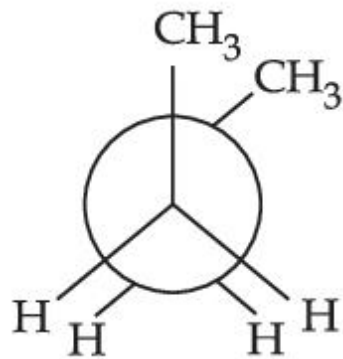

II

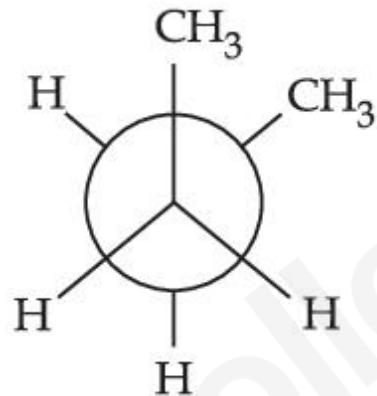

III

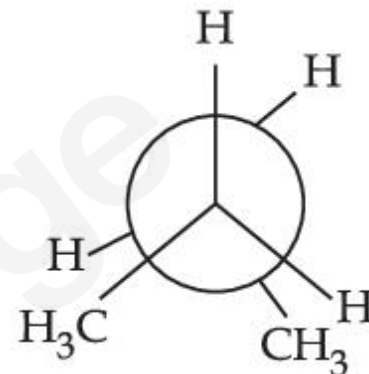

IV

Options :

86435170465. I < IV < III < II

86435170466. II < III < IV < I

86435170467. I < III < IV < II

86435170468. II < IV < III < I

Question Number : 43 Question Id : 86435121292 Question Type : MCQ Option Shuffling : Yes Is Question Mandatory : No Correct Marks : 4 Wrong Marks : 1

For the following sequence of reactions, the correct products are :

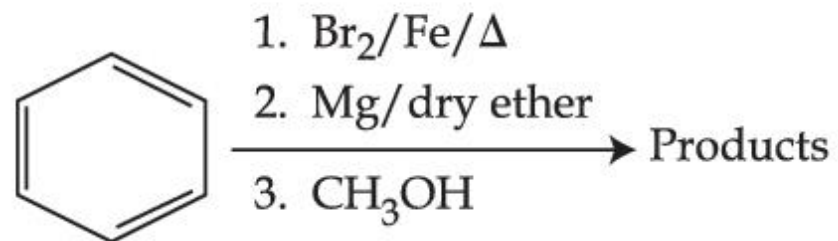

Options :

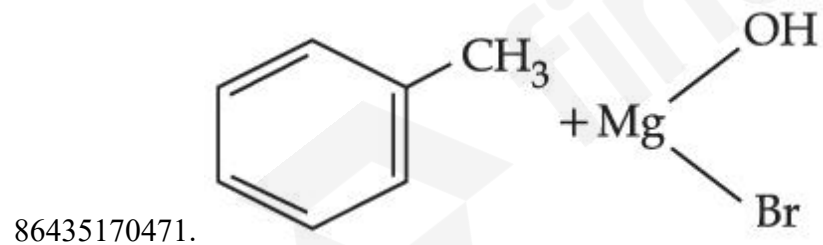
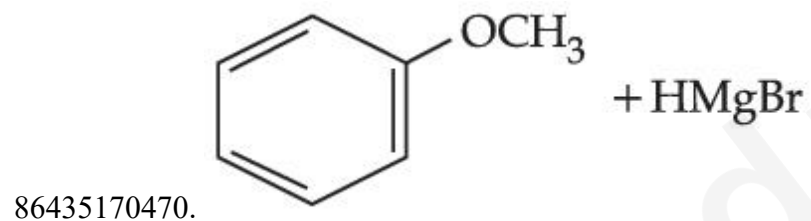
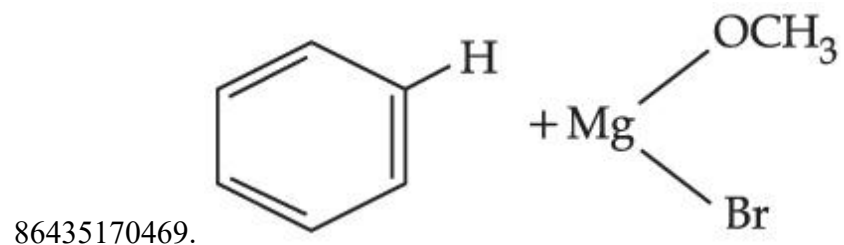

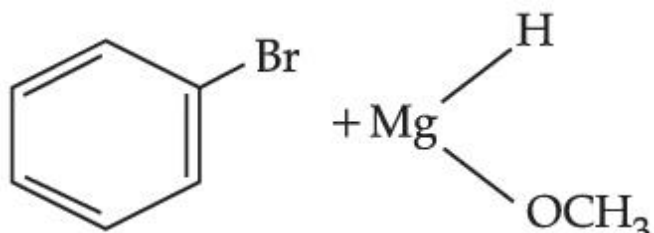

86435170472.

Question Number : 44 Question Id : 86435121293 Question Type : MCQ Option Shuffling : Yes Is Question Mandatory : No  
 Correct Marks : 4 Wrong Marks : 1

For the reaction given below :

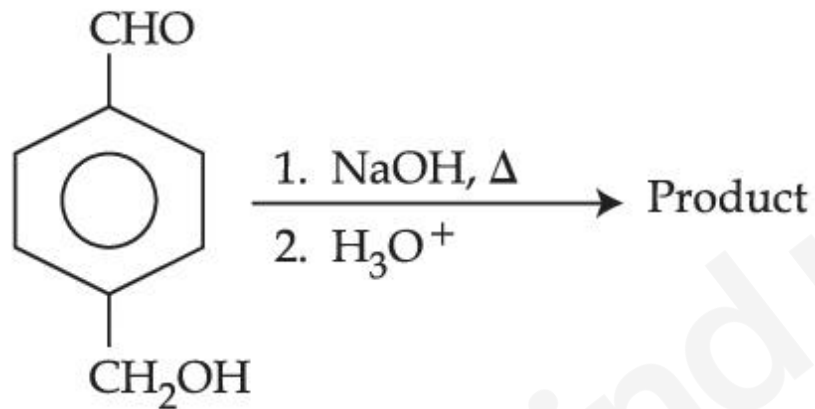

The compound which is **not** formed as a product in the reaction is a :

Options :

86435170473. diol

86435170474. dicarboxylic acid

86435170475. compound with both alcohol and acid functional groups

86435170476. monocarboxylic acid

Question Number : 45 Question Id : 86435121294 Question Type : MCQ Option Shuffling : Yes Is Question Mandatory : No Correct Marks : 4 Wrong Marks : 1

The structures of **A** and **B** formed in the following reaction are : [Ph =  $-\text{C}_6\text{H}_5$ ]

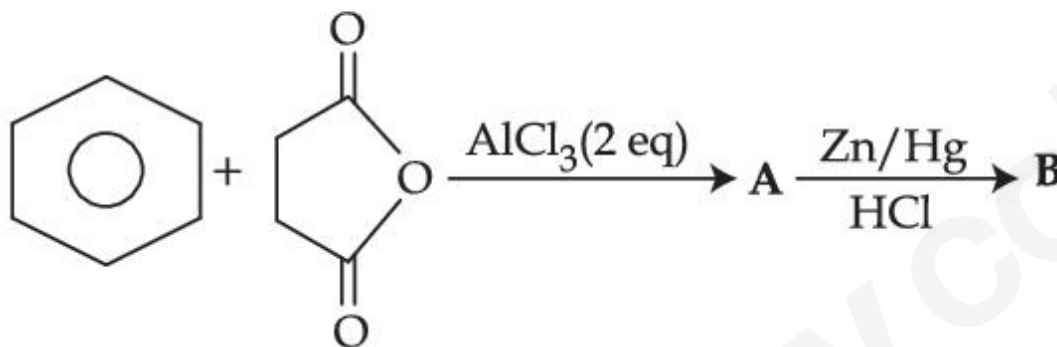

Options :

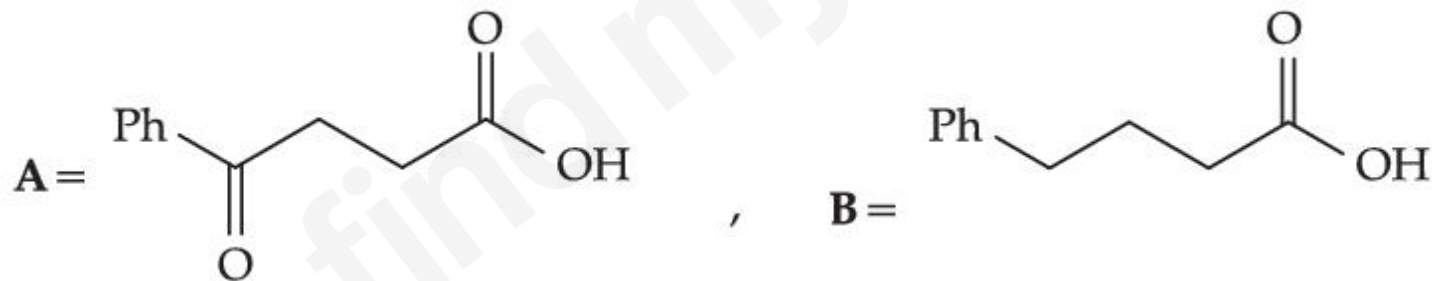

86435170477.

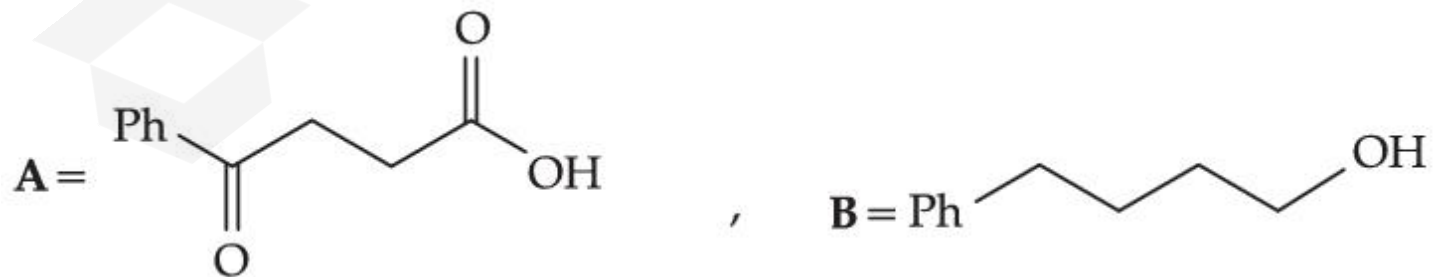

86435170478.

86435170479.

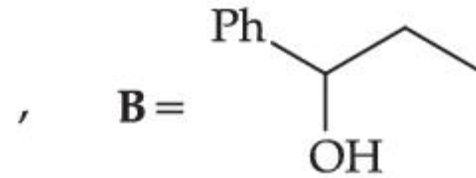
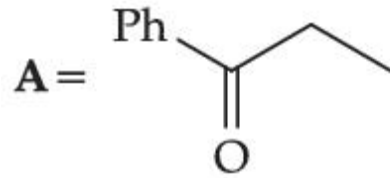

86435170480.

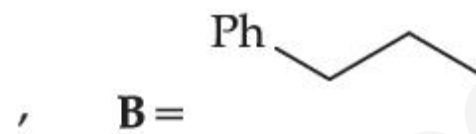
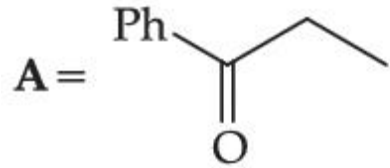

Question Number : 46 Question Id : 86435121295 Question Type : MCQ Option Shuffling : Yes Is Question Mandatory : No  
Correct Marks : 4 Wrong Marks : 1

Identify correct A, B and C in the reaction sequence given below :

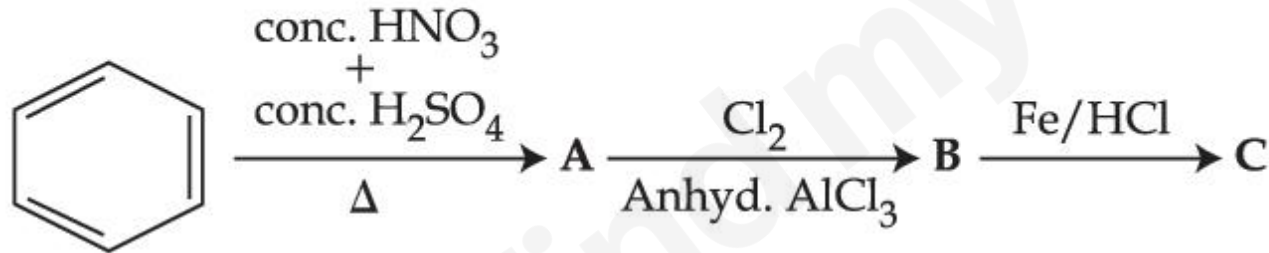

Options :

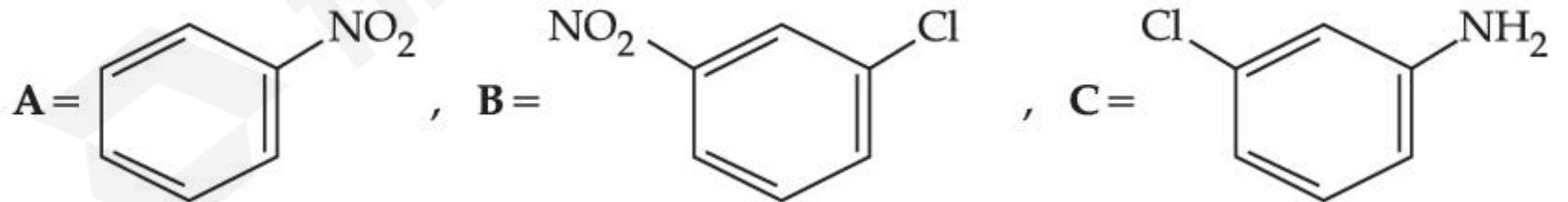

86435170481.

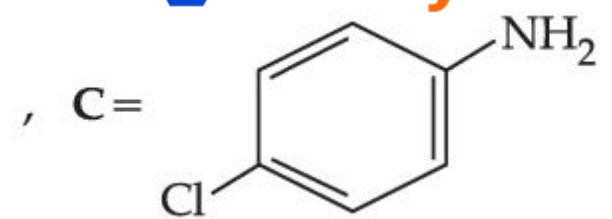
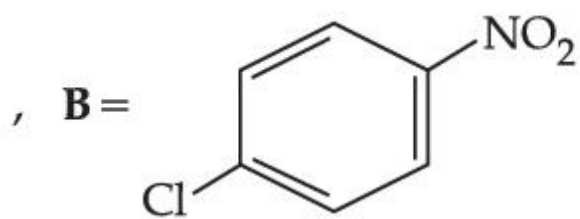
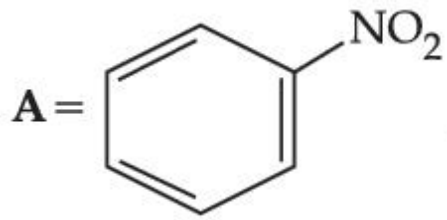

86435170482.

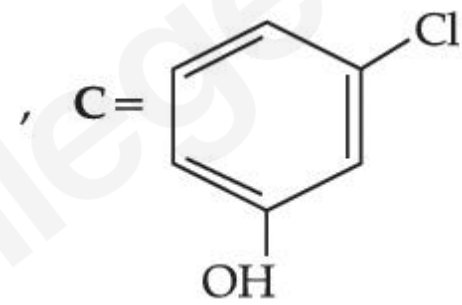
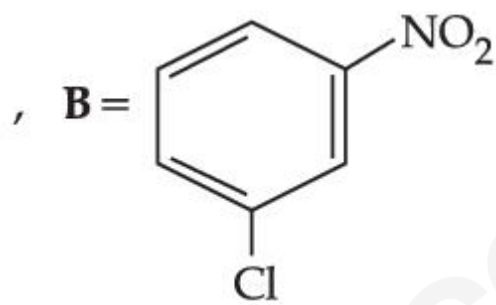
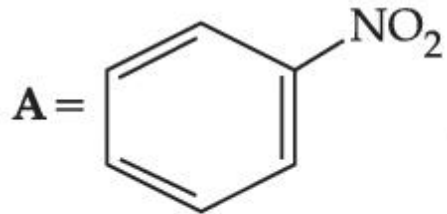

86435170483.

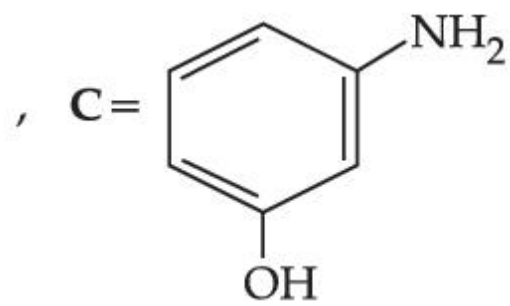
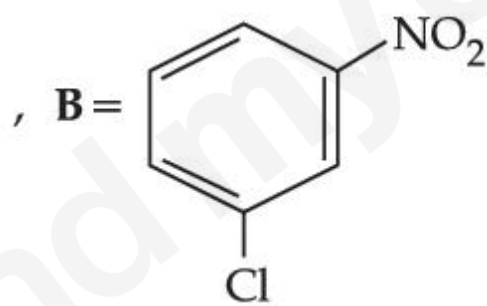
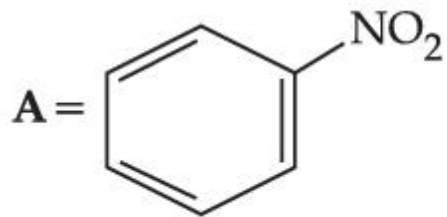

86435170484.

Question Number : 47 Question Id : 86435121296 Question Type : MCQ Option Shuffling : Yes Is Question Mandatory : No  
 Correct Marks : 4 Wrong Marks : 1

The major products A and B formed in the following reaction sequence are :

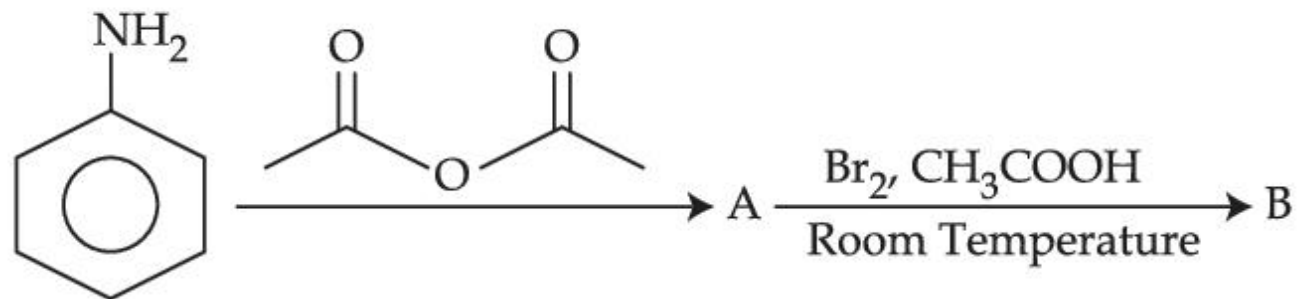

Options :

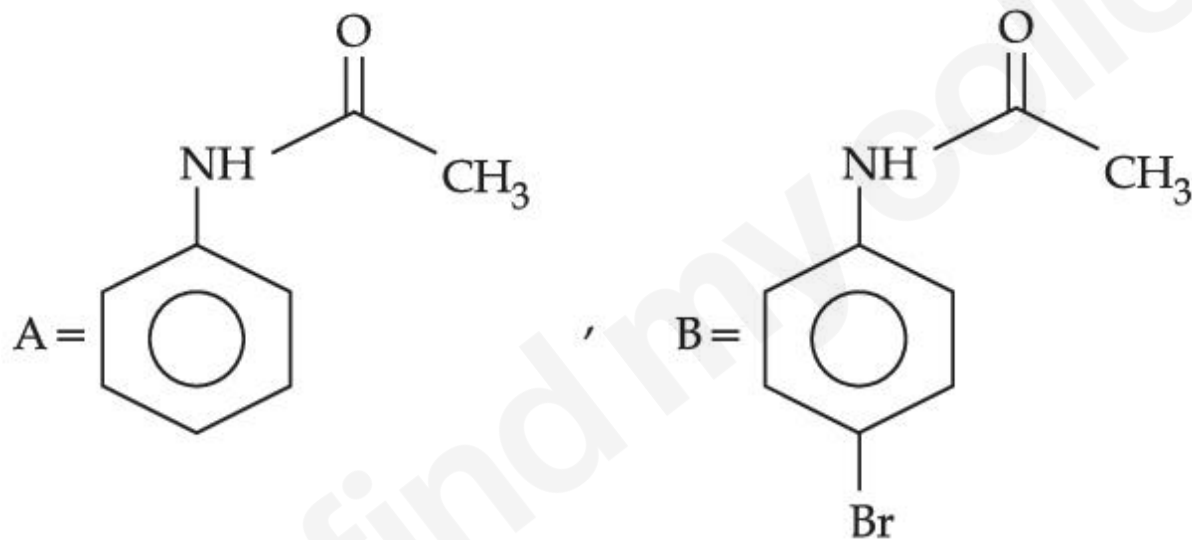

86435170485.

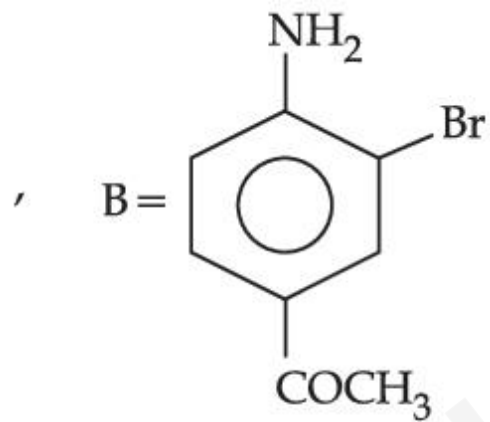
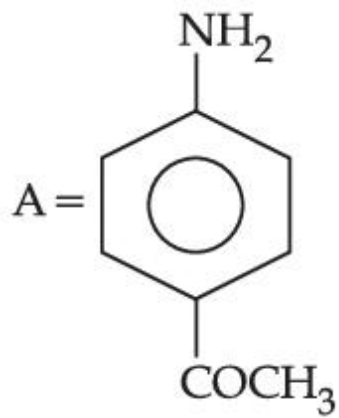

86435170486.

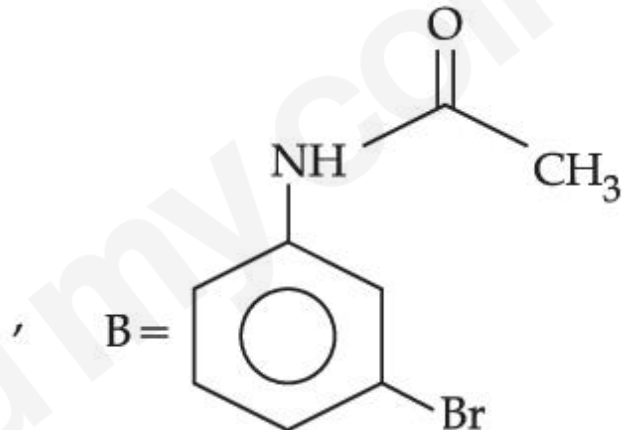
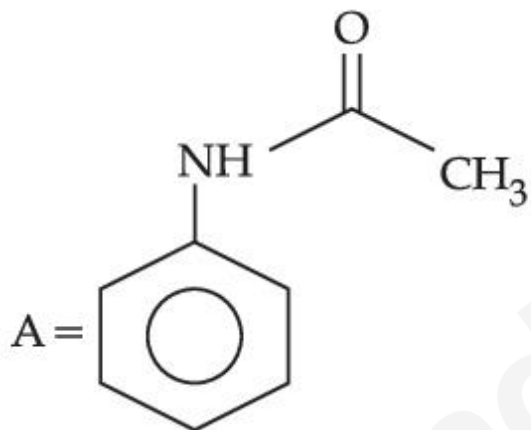

86435170487.

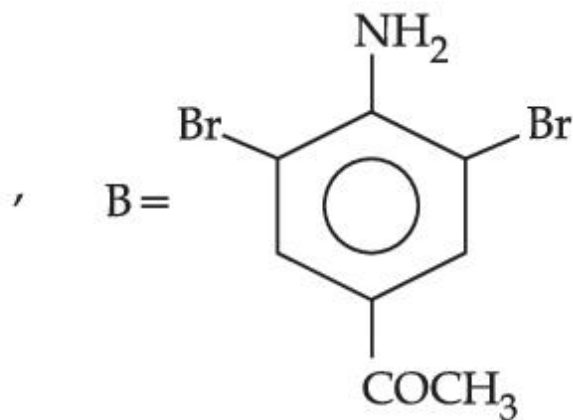
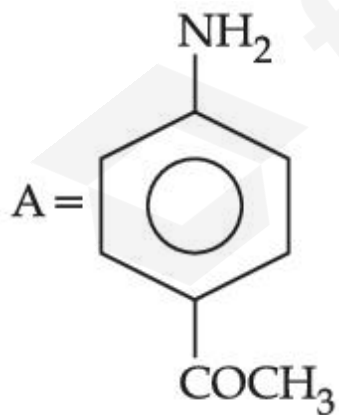

86435170488.

**Question Number : 48 Question Id : 86435121297 Question Type : MCQ Option Shuffling : Yes Is Question Mandatory : No**  
**Correct Marks : 4 Wrong Marks : 1**

Which among the following is not a polyester ?

**Options :**

86435170489. Glyptal

86435170490. Novolac

86435170491. Dacron

86435170492. PHBV

**Question Number : 49 Question Id : 86435121298 Question Type : MCQ Option Shuffling : Yes Is Question Mandatory : No**  
**Correct Marks : 4 Wrong Marks : 1**

Which of the following is NOT an example of fibrous protein ?

**Options :**

86435170493. Keratin

86435170494. Albumin

86435170495. Myosin

86435170496. Collagen

Question Number : 50 Question Id : 86435121299 Question Type : MCQ Option Shuffling : Yes Is Question Mandatory : No

Correct Marks : 4 Wrong Marks : 1

Match List - I with List - II :

List - I (Metal Ion)	List - II (Group in Qualitative analysis)
(a) $Mn^{2+}$	(i) Group - III
(b) $As^{3+}$	(ii) Group - IIA
(c) $Cu^{2+}$	(iii) Group - IV
(d) $Al^{3+}$	(iv) Group - IIB

Choose the **most appropriate** answer from the options given below :

Options :

86435170497. (a)-(i), (b)-(ii), (c)-(iii), (d)-(iv)

86435170498. (a)-(iv), (b)-(ii), (c)-(iii), (d)-(i)

86435170499. (a)-(iii), (b)-(iv), (c)-(ii), (d)-(i)

86435170500. (a)-(i), (b)-(iv), (c)-(ii), (d)-(iii)

## Chemistry Section B

Section Id :

864351989

Section Number :

4

Section type :

Online

Mandatory or Optional :

Mandatory

Number of Questions :	10
Number of Questions to be attempted :	5
Section Marks :	20
Enable Mark as Answered Mark for Review and Clear Response :	Yes
Sub-Section Number :	1
Sub-Section Id :	8643511216
Question Shuffling Allowed :	Yes

Question Number : 51 Question Id : 86435121300 Question Type : SA

Correct Marks : 4 Wrong Marks : 0

Sodium oxide reacts with water to produce sodium hydroxide. 20.0 g of sodium oxide is dissolved in 500 mL of water. Neglecting the change in volume, the concentration of the resulting NaOH solution is \_\_\_\_\_  $\times 10^{-1}$  M. (Nearest integer)

[Atomic mass : Na = 23.0, O = 16.0, H = 1.0 ]

Response Type : Numeric

Evaluation Required For SA : Yes

Show Word Count : Yes

Answers Type : Equal

Text Areas : PlainText

Possible Answers :

1

Question Number : 52 Question Id : 86435121301 Question Type : SA

Correct Marks : 4 Wrong Marks : 0

The empirical formula for a compound with a cubic close packed arrangement of anions and with cations occupying all the octahedral sites in  $A_xB$ . The value of  $x$  is \_\_\_\_\_. (Integer answer)

Response Type : Numeric

Evaluation Required For SA : Yes

Show Word Count : Yes

Answers Type : Equal

Text Areas : PlainText

Possible Answers :

1

Question Number : 53 Question Id : 86435121302 Question Type : SA

Correct Marks : 4 Wrong Marks : 0

The value of magnetic quantum number of the outermost electron of  $Zn^+$  ion is \_\_\_\_\_.  
(Integer answer)

Response Type : Numeric

Evaluation Required For SA : Yes

Show Word Count : Yes

Answers Type : Equal

Text Areas : PlainText

Possible Answers :

1

Question Number : 54 Question Id : 86435121303 Question Type : SA

Correct Marks : 4 Wrong Marks : 0

According to molecular orbital theory, the number of unpaired electron(s) in  $O_2^{2-}$  is

\_\_\_\_\_.

Response Type : Numeric

Evaluation Required For SA : Yes

Show Word Count : Yes

Answers Type : Equal

Text Areas : PlainText

Possible Answers :

1

Question Number : 55 Question Id : 86435121304 Question Type : SA

Correct Marks : 4 Wrong Marks : 0

1.22 g of an organic acid is separately dissolved in 100 g of benzene ( $K_b = 2.6 \text{ K kg mol}^{-1}$ ) and 100 g of acetone ( $K_b = 1.7 \text{ K kg mol}^{-1}$ ). The acid is known to dimerize in benzene but remain as a monomer in acetone. The boiling point of the solution in acetone increases by  $0.17^\circ\text{C}$ . The increase in boiling point of solution in benzene in  $^\circ\text{C}$  is  $x \times 10^{-2}$ . The value of  $x$  is \_\_\_\_\_. (Nearest integer)

[Atomic mass : C = 12.0, H = 1.0, O = 16.0]

Response Type : Numeric

Evaluation Required For SA : Yes

Show Word Count : Yes

Answers Type : Equal

Text Areas : PlainText

Possible Answers :

1

Question Number : 56 Question Id : 86435121305 Question Type : SA

Correct Marks : 4 Wrong Marks : 0

The pH of a solution obtained by mixing 50 mL of 1 M HCl and 30 mL of 1 M NaOH is  $x \times 10^{-4}$ . The value of  $x$  is \_\_\_\_\_. (Nearest integer)

[log 2.5 = 0.3979]

Response Type : Numeric

Evaluation Required For SA : Yes

Show Word Count : Yes

Answers Type : Equal

Text Areas : PlainText

Possible Answers :

1

Question Number : 57 Question Id : 86435121306 Question Type : SA

Correct Marks : 4 Wrong Marks : 0

For the reaction  $A \rightarrow B$ , the rate constant  $k$  (in  $s^{-1}$ ) is given by

$$\log_{10} k = 20.35 - \frac{(2.47 \times 10^3)}{T}$$

The energy of activation in  $\text{kJ mol}^{-1}$  is \_\_\_\_\_. (Nearest integer)

[Given :  $R = 8.314 \text{ J K}^{-1} \text{ mol}^{-1}$  ]

Response Type : Numeric

Evaluation Required For SA : Yes

Show Word Count : Yes

Answers Type : Equal

Text Areas : PlainText

Possible Answers :

1

Question Number : 58 Question Id : 86435121307 Question Type : SA

Correct Marks : 4 Wrong Marks : 0

$\text{CH}_4$  is adsorbed on 1 g charcoal at  $0^\circ\text{C}$  following the Freundlich adsorption isotherm.

10.0 mL of  $\text{CH}_4$  is adsorbed at 100 mm of Hg, whereas 15.0 mL is adsorbed at 200 mm of Hg.

The volume of  $\text{CH}_4$  adsorbed at 300 mm of Hg is  $10^x$  mL. The value of  $x$  is \_\_\_\_\_  $\times 10^{-2}$ .

(Nearest integer)

[Use  $\log_{10} 2 = 0.3010$ ,  $\log_{10} 3 = 0.4771$  ]

Response Type : Numeric

Evaluation Required For SA : Yes

Show Word Count : Yes

Answers Type : Equal

Text Areas : PlainText

Possible Answers :

1

Question Number : 59 Question Id : 86435121308 Question Type : SA

Correct Marks : 4 Wrong Marks : 0

In the electrolytic refining of blister copper, the total number of main impurities, from the following, removed as anode mud is \_\_\_\_\_.

Pb, Sb, Se, Te, Ru, Ag, Au and Pt

Response Type : Numeric

Evaluation Required For SA : Yes

Show Word Count : Yes

Answers Type : Equal

Text Areas : PlainText

Possible Answers :

1

Question Number : 60 Question Id : 86435121309 Question Type : SA

Correct Marks : 4 Wrong Marks : 0

The transformation occurring in Duma's method is given below

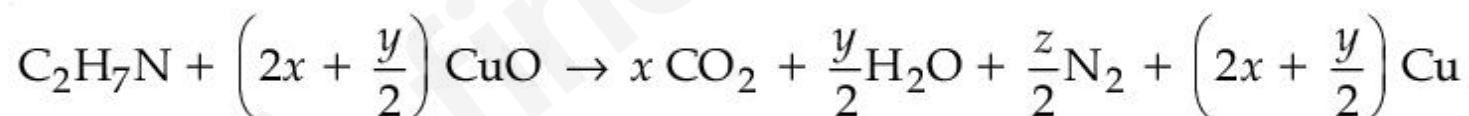

The value of  $y$  is \_\_\_\_\_. (Integer answer)

Response Type : Numeric

Evaluation Required For SA : Yes

Show Word Count : Yes

Answers Type : Equal

Text Areas : PlainText

Possible Answers :

1

## Mathematics Section A

Section Id :	864351990
Section Number :	5
Section type :	Online
Mandatory or Optional :	Mandatory
Number of Questions :	20
Number of Questions to be attempted :	20
Section Marks :	80
Enable Mark as Answered Mark for Review and Clear Response :	Yes
Sub-Section Number :	1
Sub-Section Id :	8643511217
Question Shuffling Allowed :	Yes

Question Number : 61 Question Id : 86435121310 Question Type : MCQ Option Shuffling : Yes Is Question Mandatory : No  
Correct Marks : 4 Wrong Marks : 1

Let  $f : \mathbf{N} \rightarrow \mathbf{N}$  be a function such that  $f(m+n) = f(m) + f(n)$  for every  $m, n \in \mathbf{N}$ . If  $f(6) = 18$ , then  $f(2) \cdot f(3)$  is equal to :

Options :

86435170511. 6

86435170512. 18

86435170513. 36

86435170514. 54

Question Number : 62 Question Id : 86435121311 Question Type : MCQ Option Shuffling : Yes Is Question Mandatory : No

Correct Marks : 4 Wrong Marks : 1

If  $z$  is a complex number such that  $\frac{z-i}{z-1}$  is purely imaginary, then the minimum value of  $|z - (3 + 3i)|$  is :

Options :

86435170515.  $2\sqrt{2} - 1$

86435170516.  $2\sqrt{2}$

86435170517.  $3\sqrt{2}$

86435170518.  $6\sqrt{2}$

Question Number : 63 Question Id : 86435121312 Question Type : MCQ Option Shuffling : Yes Is Question Mandatory : No

Correct Marks : 4 Wrong Marks : 1

The sum of the roots of the equation,  
 $x + 1 - 2\log_2(3 + 2^x) + 2\log_4(10 - 2^{-x}) = 0$ , is :

Options :

86435170519.  $\log_2 11$

86435170520.  $\log_2 12$

86435170521.  $\log_2 13$

86435170522.  $\log_2 14$

**Question Number : 64 Question Id : 86435121313 Question Type : MCQ Option Shuffling : Yes Is Question Mandatory : No Correct Marks : 4 Wrong Marks : 1**

If  $\alpha + \beta + \gamma = 2\pi$ , then the system of equations

$$x + (\cos\gamma)y + (\cos\beta)z = 0$$

$$(\cos\gamma)x + y + (\cos\alpha)z = 0$$

$$(\cos\beta)x + (\cos\alpha)y + z = 0$$

has :

**Options :**

86435170523. infinitely many solutions

86435170524. no solution

86435170525. a unique solution

86435170526. exactly two solutions

**Question Number : 65 Question Id : 86435121314 Question Type : MCQ Option Shuffling : Yes Is Question Mandatory : No Correct Marks : 4 Wrong Marks : 1**

Let  $a_1, a_2, a_3, \dots$  be an A.P. If  $\frac{a_1 + a_2 + \dots + a_{10}}{a_1 + a_2 + \dots + a_p} = \frac{100}{p^2}$ ,  $p \neq 10$ , then  $\frac{a_{11}}{a_{10}}$  is equal to :

Options :

86435170527.  $\frac{121}{100}$

86435170528.  $\frac{21}{19}$

86435170529.  $\frac{19}{21}$

86435170530.  $\frac{100}{121}$

Question Number : 66 Question Id : 86435121315 Question Type : MCQ Option Shuffling : Yes Is Question Mandatory : No Correct Marks : 4 Wrong Marks : 1

An angle of intersection of the curves,  $\frac{x^2}{a^2} + \frac{y^2}{b^2} = 1$  and  $x^2 + y^2 = ab$ ,  $a > b$ , is :

Options :

86435170531.  $\tan^{-1}\left(\frac{a-b}{\sqrt{ab}}\right)$

86435170532.  $\tan^{-1}\left(\frac{a+b}{\sqrt{ab}}\right)$

86435170533.  $\tan^{-1}\left(\frac{a-b}{2\sqrt{ab}}\right)$

86435170534.  $\tan^{-1}(2\sqrt{ab})$

**Question Number : 67 Question Id : 86435121316 Question Type : MCQ Option Shuffling : Yes Is Question Mandatory : No Correct Marks : 4 Wrong Marks : 1**

If  $\alpha = \lim_{x \rightarrow \pi/4} \frac{\tan^3 x - \tan x}{\cos\left(x + \frac{\pi}{4}\right)}$  and  $\beta = \lim_{x \rightarrow 0} (\cos x)^{\cot x}$  are the roots of the equation,

$ax^2 + bx - 4 = 0$ , then the ordered pair (a, b) is :

**Options :**

86435170535.  $(-1, 3)$

86435170536.  $(1, -3)$

86435170537.  $(1, 3)$

86435170538.  $(-1, -3)$

**Question Number : 68 Question Id : 86435121317 Question Type : MCQ Option Shuffling : Yes Is Question Mandatory : No**

Correct Marks : 4 Wrong Marks : 1

Let  $f$  be any continuous function on  $[0, 2]$  and twice differentiable on  $(0, 2)$ . If  $f(0) = 0$ ,  $f(1) = 1$  and  $f(2) = 2$ , then :

Options :

86435170539.  $f'(x) = 0$  for some  $x \in [0, 2]$

86435170540.  $f''(x) > 0$  for all  $x \in (0, 2)$

86435170541.  $f''(x) = 0$  for some  $x \in (0, 2)$

86435170542.  $f''(x) = 0$  for all  $x \in (0, 2)$

Question Number : 69 Question Id : 86435121318 Question Type : MCQ Option Shuffling : Yes Is Question Mandatory : No

Correct Marks : 4 Wrong Marks : 1

If  $[x]$  is the greatest integer  $\leq x$ , then  $\pi^2 \int_0^2 \left( \sin \frac{\pi x}{2} \right) (x - [x])^{[x]} dx$  is equal to :

Options :

86435170543.  $2(\pi + 1)$

86435170544.  $2(\pi - 1)$

86435170545.  $4(\pi + 1)$

86435170546.  $4(\pi - 1)$

**Question Number : 70 Question Id : 86435121319 Question Type : MCQ Option Shuffling : Yes Is Question Mandatory : No**  
**Correct Marks : 4 Wrong Marks : 1**

If  $\frac{dy}{dx} = \frac{2^x y + 2^y \cdot 2^x}{2^x + 2^{x+y} \log_e 2}$ ,  $y(0) = 0$ , then for  $y = 1$ , the value of  $x$  lies in the interval :

**Options :**

86435170547.  $\left(0, \frac{1}{2}\right]$

86435170548.  $\left[\frac{1}{2}, 1\right]$

86435170549.  $(1, 2)$

86435170550.  $(2, 3)$

**Question Number : 71 Question Id : 86435121320 Question Type : MCQ Option Shuffling : Yes Is Question Mandatory : No**  
**Correct Marks : 4 Wrong Marks : 1**

If  $y \frac{dy}{dx} = x \left[ \frac{y^2}{x^2} + \frac{\phi\left(\frac{y^2}{x^2}\right)}{\phi'\left(\frac{y^2}{x^2}\right)} \right]$ ,  $x > 0$ ,  $\phi > 0$ , and  $y(1) = -1$ , then  $\phi\left(\frac{y^2}{4}\right)$  is equal to :

Options :

86435170551.  $\phi(1)$

86435170552.  $2\phi(1)$

86435170553.  $4\phi(1)$

86435170554.  $4\phi(2)$

Question Number : 72 Question Id : 86435121321 Question Type : MCQ Option Shuffling : Yes Is Question Mandatory : No

Correct Marks : 4 Wrong Marks : 1

Let A be the set of all points  $(\alpha, \beta)$  such that the area of triangle formed by the points  $(5, 6)$ ,  $(3, 2)$  and  $(\alpha, \beta)$  is 12 square units. Then the least possible length of a line segment joining the origin to a point in A, is :

Options :

86435170555.  $\frac{8}{\sqrt{5}}$

86435170556.  $\frac{4}{\sqrt{5}}$

86435170557.  $\frac{16}{\sqrt{5}}$

86435170558.  $\frac{12}{\sqrt{5}}$

**Question Number : 73 Question Id : 86435121322 Question Type : MCQ Option Shuffling : Yes Is Question Mandatory : No Correct Marks : 4 Wrong Marks : 1**

The locus of mid-points of the line segments joining  $(-3, -5)$  and the points on the ellipse

$$\frac{x^2}{4} + \frac{y^2}{9} = 1 \text{ is :}$$

**Options :**

86435170559.  $36x^2 + 16y^2 + 90x + 56y + 145 = 0$

86435170560.  $9x^2 + 4y^2 + 18x + 8y + 145 = 0$

86435170561.  $36x^2 + 16y^2 + 72x + 32y + 145 = 0$

86435170562.  $36x^2 + 16y^2 + 108x + 80y + 145 = 0$

Question Number : 74 Question Id : 86435121323 Question Type : MCQ Option Shuffling : Yes Is Question Mandatory : No

Correct Marks : 4 Wrong Marks : 1

The distance of the point  $(-1, 2, -2)$  from the line of intersection of the planes  $2x + 3y + 2z = 0$  and  $x - 2y + z = 0$  is :

Options :

86435170563.  $\frac{1}{\sqrt{2}}$

86435170564.  $\frac{5}{2}$

86435170565.  $\frac{\sqrt{34}}{2}$

86435170566.  $\frac{\sqrt{42}}{2}$

Question Number : 75 Question Id : 86435121324 Question Type : MCQ Option Shuffling : Yes Is Question Mandatory : No

Correct Marks : 4 Wrong Marks : 1

Let  $\vec{a}$ ,  $\vec{b}$ ,  $\vec{c}$  be three vectors mutually perpendicular to each other and have same magnitude.

If a vector  $\vec{r}$  satisfies

$\vec{a} \times \{(\vec{r} - \vec{b}) \times \vec{a}\} + \vec{b} \times \{(\vec{r} - \vec{c}) \times \vec{b}\} + \vec{c} \times \{(\vec{r} - \vec{a}) \times \vec{c}\} = \vec{0}$ , then  $\vec{r}$  is equal to :

Options :

86435170567.  $\frac{1}{2} (\vec{a} + \vec{b} + 2\vec{c})$

86435170568.  $\frac{1}{2} (\vec{a} + \vec{b} + \vec{c})$

86435170569.  $\frac{1}{3} (\vec{a} + \vec{b} + \vec{c})$

86435170570.  $\frac{1}{3} (2\vec{a} + \vec{b} - \vec{c})$

Question Number : 76 Question Id : 86435121325 Question Type : MCQ Option Shuffling : Yes Is Question Mandatory : No

Correct Marks : 4 Wrong Marks : 1

Let  $S = \{1, 2, 3, 4, 5, 6\}$ . Then the probability that a randomly chosen onto function  $g$  from  $S$  to  $S$  satisfies  $g(3) = 2g(1)$  is :

Options :

86435170571.  $\frac{1}{30}$

86435170572.  $\frac{1}{15}$

86435170573.  $\frac{1}{10}$

86435170574.  $\frac{1}{5}$

Question Number : 77 Question Id : 86435121326 Question Type : MCQ Option Shuffling : Yes Is Question Mandatory : No

Correct Marks : 4 Wrong Marks : 1

The mean and variance of 7 observations are 8 and 16 respectively. If two observations are 6 and 8, then the variance of the remaining 5 observations is :

Options :

86435170575.  $\frac{92}{5}$

86435170576.  $\frac{536}{25}$

$$86435170577. \quad \frac{112}{5}$$

$$86435170578. \quad \frac{134}{5}$$

**Question Number : 78 Question Id : 86435121327 Question Type : MCQ Option Shuffling : Yes Is Question Mandatory : No Correct Marks : 4 Wrong Marks : 1**

The number of solutions of the equation  $32^{\tan^2 x} + 32^{\sec^2 x} = 81$ ,  $0 \leq x \leq \frac{\pi}{4}$  is :

**Options :**

$$86435170579. \quad 0$$

$$86435170580. \quad 1$$

$$86435170581. \quad 2$$

$$86435170582. \quad 3$$

**Question Number : 79 Question Id : 86435121328 Question Type : MCQ Option Shuffling : Yes Is Question Mandatory : No Correct Marks : 4 Wrong Marks : 1**

The domain of the function

$$f(x) = \sin^{-1}\left(\frac{3x^2 + x - 1}{(x - 1)^2}\right) + \cos^{-1}\left(\frac{x - 1}{x + 1}\right) \text{ is :}$$

Options :

86435170583.  $\left[0, \frac{1}{4}\right]$

86435170584.  $\left[0, \frac{1}{2}\right]$

86435170585.  $\left[\frac{1}{4}, \frac{1}{2}\right] \cup \{0\}$

86435170586.  $[-2, 0] \cup \left[\frac{1}{4}, \frac{1}{2}\right]$

Question Number : 80 Question Id : 86435121329 Question Type : MCQ Option Shuffling : Yes Is Question Mandatory : No

Correct Marks : 4 Wrong Marks : 1

Negation of the statement  $(p \vee r) \Rightarrow (q \vee r)$  is :

Options :

86435170587.  $p \wedge q \wedge r$

86435170588.  $\sim p \wedge q \wedge r$

86435170589.  $p \wedge \sim q \wedge \sim r$

86435170590.  $\sim p \wedge q \wedge \sim r$

## Mathematics Section B

<b>Section Id :</b>	864351991
<b>Section Number :</b>	6
<b>Section type :</b>	Online
<b>Mandatory or Optional :</b>	Mandatory
<b>Number of Questions :</b>	10
<b>Number of Questions to be attempted :</b>	5
<b>Section Marks :</b>	20
<b>Enable Mark as Answered Mark for Review and Clear Response :</b>	Yes
<b>Sub-Section Number :</b>	1
<b>Sub-Section Id :</b>	8643511218
<b>Question Shuffling Allowed :</b>	Yes

**Question Number : 81 Question Id : 86435121330 Question Type : SA**

**Correct Marks : 4 Wrong Marks : 0**

The number of elements in the set

$\left\{ A = \begin{pmatrix} a & b \\ 0 & d \end{pmatrix} : a, b, d \in \{-1, 0, 1\} \text{ and } (I - A)^3 = I - A^3 \right\}$ , where  $I$  is  $2 \times 2$  identity matrix, is

\_\_\_\_\_.

**Response Type : Numeric**

**Evaluation Required For SA : Yes**

**Show Word Count : Yes**

**Answers Type : Equal**

**Text Areas : PlainText**

**Possible Answers :**

1

**Question Number : 82 Question Id : 86435121331 Question Type : SA**

**Correct Marks : 4 Wrong Marks : 0**

The number of 4-digit numbers which are neither multiple of 7 nor multiple of 3 is \_\_\_\_\_.

**Response Type : Numeric**

**Evaluation Required For SA : Yes**

**Show Word Count : Yes**

**Answers Type : Equal**

**Text Areas : PlainText**

**Possible Answers :**

1

**Question Number : 83 Question Id : 86435121332 Question Type : SA**

**Correct Marks : 4 Wrong Marks : 0**

If the coefficient of  $a^7b^8$  in the expansion of  $(a + 2b + 4ab)^{10}$  is  $K \cdot 2^{16}$ , then K is equal to

\_\_\_\_\_.

**Response Type : Numeric**

**Evaluation Required For SA : Yes**

**Show Word Count : Yes**

**Answers Type : Equal**

**Text Areas : PlainText**

**Possible Answers :**

1

**Question Number : 84 Question Id : 86435121333 Question Type : SA**

Correct Marks : 4 Wrong Marks : 0

If  $S = \frac{7}{5} + \frac{9}{5^2} + \frac{13}{5^3} + \frac{19}{5^4} + \dots$ , then  $160S$  is equal to \_\_\_\_\_.

Response Type : Numeric

Evaluation Required For SA : Yes

Show Word Count : Yes

Answers Type : Equal

Text Areas : PlainText

Possible Answers :

1

Question Number : 85 Question Id : 86435121334 Question Type : SA

Correct Marks : 4 Wrong Marks : 0

Let  $f(x)$  be a cubic polynomial with  $f(1) = -10$ ,  $f(-1) = 6$ , and has a local minima at  $x = 1$ , and  $f'(x)$  has a local minima at  $x = -1$ . Then  $f(3)$  is equal to \_\_\_\_\_.

Response Type : Numeric

Evaluation Required For SA : Yes

Show Word Count : Yes

Answers Type : Equal

Text Areas : PlainText

Possible Answers :

1

Question Number : 86 Question Id : 86435121335 Question Type : SA

Correct Marks : 4 Wrong Marks : 0

If  $\int \frac{\sin x}{\sin^3 x + \cos^3 x} dx = \alpha \log_e |1 + \tan x| + \beta \log_e |1 - \tan x + \tan^2 x| + \gamma \tan^{-1} \left( \frac{2 \tan x - 1}{\sqrt{3}} \right) + C$ ,

when  $C$  is constant of integration, then the value of  $18(\alpha + \beta + \gamma^2)$  is \_\_\_\_\_.

**Response Type :** Numeric

**Evaluation Required For SA :** Yes

**Show Word Count :** Yes

**Answers Type :** Equal

**Text Areas :** PlainText

**Possible Answers :**

1

**Question Number :** 87 **Question Id :** 86435121336 **Question Type :** SA

**Correct Marks :** 4 **Wrong Marks :** 0

If the line  $y = mx$  bisects the area enclosed by the lines  $x = 0$ ,  $y = 0$ ,  $x = \frac{3}{2}$  and the curve  $y = 1 + 4x - x^2$ , then  $12m$  is equal to \_\_\_\_\_.

**Response Type :** Numeric

**Evaluation Required For SA :** Yes

**Show Word Count :** Yes

**Answers Type :** Equal

**Text Areas :** PlainText

**Possible Answers :**

1

**Question Number :** 88 **Question Id :** 86435121337 **Question Type :** SA

**Correct Marks :** 4 **Wrong Marks :** 0

Let B be the centre of the circle  $x^2 + y^2 - 2x + 4y + 1 = 0$ . Let the tangents at two points P and Q on the circle intersect at the point A(3, 1). Then  $8 \cdot \left( \frac{\text{area } \Delta APQ}{\text{area } \Delta BPQ} \right)$  is equal to \_\_\_\_\_.

**Response Type :** Numeric

**Evaluation Required For SA :** Yes

**Show Word Count :** Yes

Answers Type : Equal

Text Areas : PlainText

Possible Answers :

1

Question Number : 89 Question Id : 86435121338 Question Type : SA

Correct Marks : 4 Wrong Marks : 0

A tangent line L is drawn at the point  $(2, -4)$  on the parabola  $y^2 = 8x$ . If the line L is also tangent to the circle  $x^2 + y^2 = a$ , then 'a' is equal to \_\_\_\_\_.

Response Type : Numeric

Evaluation Required For SA : Yes

Show Word Count : Yes

Answers Type : Equal

Text Areas : PlainText

Possible Answers :

1

Question Number : 90 Question Id : 86435121339 Question Type : SA

Correct Marks : 4 Wrong Marks : 0

Suppose the line  $\frac{x - 2}{\alpha} = \frac{y - 2}{-5} = \frac{z + 2}{2}$  lies on the plane  $x + 3y - 2z + \beta = 0$ . Then  $(\alpha + \beta)$  is equal to \_\_\_\_\_.

Response Type : Numeric

Evaluation Required For SA : Yes

Show Word Count : Yes

Answers Type : Equal

Text Areas : PlainText

Possible Answers :

1