

|                              |                                 |
|------------------------------|---------------------------------|
| <b>Question Paper Name :</b> | B TECH EA 26th Feb 2021 Shift 2 |
| <b>Subject Name :</b>        | B TECH EA                       |
| <b>Creation Date :</b>       | 2021-02-25 13:51:25             |
| <b>Duration :</b>            | 180                             |
| <b>Number of Questions :</b> | 90                              |
| <b>Total Marks :</b>         | 300                             |
| <b>Display Marks:</b>        | Yes                             |

## B TECH EA

|                                      |           |
|--------------------------------------|-----------|
| <b>Group Number :</b>                | 1         |
| <b>Group Id :</b>                    | 708191230 |
| <b>Group Maximum Duration :</b>      | 0         |
| <b>Group Minimum Duration :</b>      | 180       |
| <b>Show Attended Group? :</b>        | No        |
| <b>Edit Attended Group? :</b>        | No        |
| <b>Break time :</b>                  | 0         |
| <b>Group Marks :</b>                 | 300       |
| <b>Is this Group for Examiner? :</b> | No        |

## Physics Section A

|                         |           |
|-------------------------|-----------|
| <b>Section Id :</b>     | 708191958 |
| <b>Section Number :</b> | 1         |
| <b>Section type :</b>   | Online    |

|                                       |            |
|---------------------------------------|------------|
| Mandatory or Optional :               | Mandatory  |
| Number of Questions :                 | 20         |
| Number of Questions to be attempted : | 20         |
| Section Marks :                       | 80         |
| Mark As Answered Required? :          | Yes        |
| Sub-Section Number :                  | 1          |
| Sub-Section Id :                      | 7081911238 |
| Question Shuffling Allowed :          | Yes        |

Question Number : 1 Question Id : 70819121274 Question Type : MCQ Option Shuffling : Yes Is Question Mandatory : No

Correct Marks : 4 Wrong Marks : 1

A radioactive sample is undergoing  $\alpha$  decay. At any time  $t_1$ , its activity is  $A$  and another time  $t_2$ , the activity is  $\frac{A}{5}$ . What is the average life time for the sample ?

Options :

70819168971.  $\frac{\ln 5}{t_2 - t_1}$

70819168972.  $\frac{\ln(t_2 + t_1)}{2}$

70819168973.  $\frac{t_2 - t_1}{\ln 5}$

70819168974.  $\frac{t_1 - t_2}{\ln 5}$

Question Number : 1 Question Id : 70819121274 Question Type : MCQ Option Shuffling : Yes Is Question Mandatory : No

Correct Marks : 4 Wrong Marks : 1

এটা তেজস্ক্রিয় নমুনাৰ  $\alpha$ -বিঘটন হৈছে।  $t_1$  সময়ত ইয়াৰ সক্ৰিয়তা A আৰু আন এক সময়  $t_2$  ত ইয়াৰ সক্ৰিয়তা  $\frac{A}{5}$ ।

নমুনাটোৰ গড় আয়ু কি হ'ব ?

**Options :**

70819168971.  $\frac{\ln 5}{t_2 - t_1}$

70819168972.  $\frac{\ln(t_2 + t_1)}{2}$

70819168973.  $\frac{t_2 - t_1}{\ln 5}$

70819168974.  $\frac{t_1 - t_2}{\ln 5}$

**Question Number : 2 Question Id : 70819121275 Question Type : MCQ Option Shuffling : Yes Is**

**Question Mandatory : No**

**Correct Marks : 4 Wrong Marks : 1**

Given below are two statements : one is labeled as Assertion A and the other is labeled as Reason R.

Assertion A : For a simple microscope, the angular size of the object equals the angular size of the image.

Reason R : Magnification is achieved as the small object can be kept much closer to the eye than 25 cm and hence it subtends a large angle.

In the light of the above statements, choose the most appropriate answer from the options given below :

**Options :**

70819168975. Both A and R are true and R is the correct explanation of A

70819168976. Both A and R are true but R is NOT the correct explanation of A

70819168977. A is true but R is false

70819168978. A is false but R is true

**Question Number : 2 Question Id : 70819121275 Question Type : MCQ Option Shuffling : Yes Is**

**Question Mandatory : No**

**Correct Marks : 4 Wrong Marks : 1**

তলত দুটা উক্তি দিয়া আছে : এটাক বিবৃতি A আৰু আনটোক কাৰণ R ৰূপে নামাকৰণ কৰা হৈছে।

বিবৃতি A : এটা সৰল মাইক্ৰ'স্ক'পৰ বাবে, লক্ষ্যবস্তুৰ কৌণিক আকাৰ প্ৰতিবিস্তৰ কৌণিক আকাৰৰ সমান।

কাৰণ R : যিহেতু এটা সূক্ষ্ম লক্ষ্যবস্তুক চকুৰ পৰা 25 cm তকৈও ওচৰত ৰাখিব পৰা যায় আৰু গতিকে ই এটা ডাঙৰ কোণ কৰে, সেই কাৰণে পৰিৱৰ্তন সম্ভৱ হয়।

উপৰোক্ত উক্তিৰ প্ৰকাশত, তলৰ বিকল্পৰ পৰা শুদ্ধ উত্তৰ চয়ন কৰা।

**Options :**

70819168975. A আৰু R দুয়োটাই সঁচা আৰু R, A ৰ শুদ্ধ ব্যাখ্যা।

70819168976. A আৰু R দুয়োটাই সঁচা কিন্তু R, A ৰ শুদ্ধ ব্যাখ্যা নহয়।

70819168977. A সঁচা কিন্তু R মিছা।

70819168978. A মিছা কিন্তু R সঁচা।

**Question Number : 3 Question Id : 70819121276 Question Type : MCQ Option Shuffling : Yes Is**

**Question Mandatory : No**

**Correct Marks : 4 Wrong Marks : 1**

A tuning fork A of unknown frequency produces 5 beats/s with a fork of known frequency 340 Hz. When fork A is filed, the beat frequency decreases to 2 beats/s. What is the frequency of fork A ?

**Options :**

70819168979. 335 Hz

70819168980. 338 Hz

70819168981. 345 Hz

70819168982. 342 Hz

**Question Number : 3 Question Id : 70819121276 Question Type : MCQ Option Shuffling : Yes Is**

**Question Mandatory : No**

**Correct Marks : 4 Wrong Marks : 1**

অজ্ঞাত কম্পনাংকৰ সুৰ-শলা A ই, 340 Hz কম্পনাংকৰ এটা জ্ঞাত শলাৰ সৈতে প্রতি ছেকেণ্ডত 5 টা স্বৰকম্প (beat) উৎপন্ন কৰে। যদিহে A শলাডাল ঘঁহি পাতল কৰা হয়, স্বৰকম্পৰ কম্পনাংক 2 স্বৰকম্প প্রতি ছেকেণ্ডলৈ হ্রাস পায়। A শলাডালৰ কম্পনাংক কিমান ?

**Options :**

70819168979. 335 Hz

70819168980. 338 Hz

70819168981. 345 Hz

70819168982. 342 Hz

**Question Number : 4 Question Id : 70819121277 Question Type : MCQ Option Shuffling : Yes Is**

**Question Mandatory : No**

**Correct Marks : 4 Wrong Marks : 1**

Draw the output signal Y in the given combination of gates.

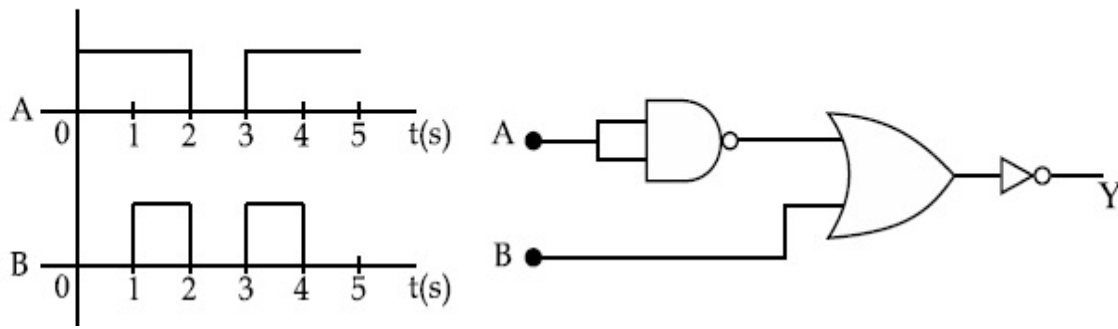

**Options :**

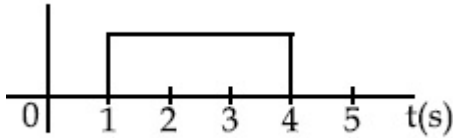

70819168983.

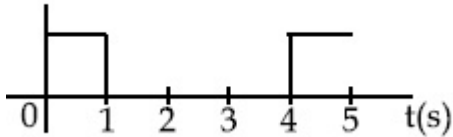

70819168984.

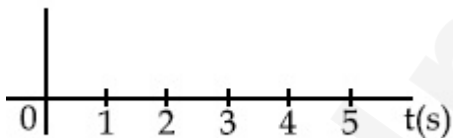

70819168985.

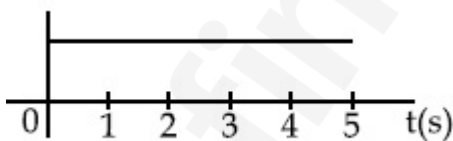

70819168986.

**Question Number : 4 Question Id : 70819121277 Question Type : MCQ Option Shuffling : Yes Is Question Mandatory : No**

**Correct Marks : 4 Wrong Marks : 1**

তলৰ গোট সজ্জাৰ বাবে আউটপুট সংকেত Y অংকন কৰা।

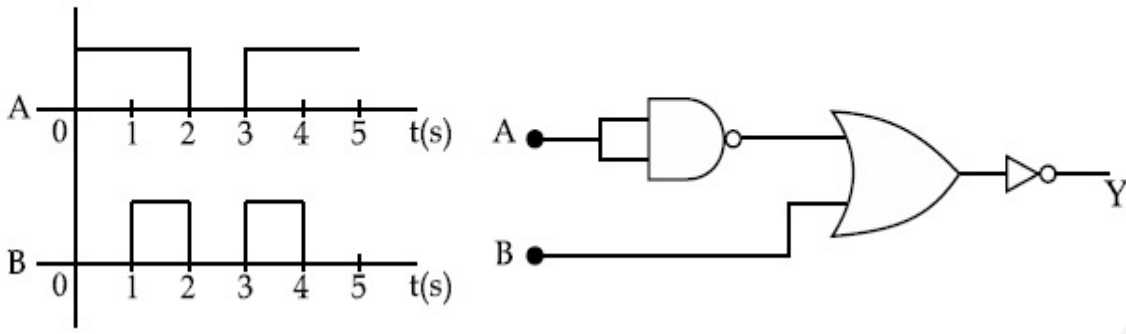

Options :

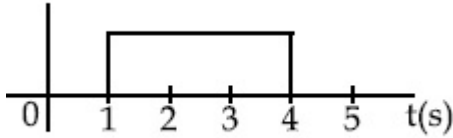

70819168983.

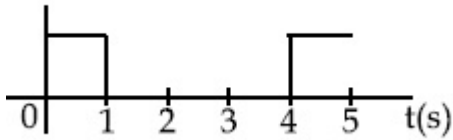

70819168984.

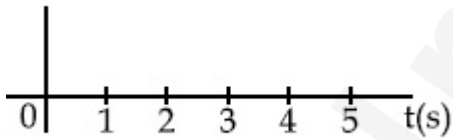

70819168985.

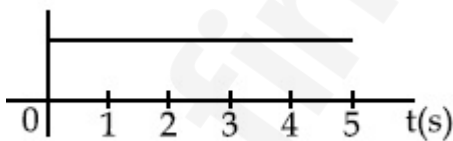

70819168986.

Question Number : 5 Question Id : 70819121278 Question Type : MCQ Option Shuffling : Yes Is

Question Mandatory : No

Correct Marks : 4 Wrong Marks : 1

Given below are two statements :

Statement I : A second's pendulum has a time period of 1 second.

Statement II : It takes precisely one second to move between the two extreme positions.

In the light of the above statements, choose the correct answer from the options given below :

**Options :**

70819168987. Both Statement I and Statement II are true

70819168988. Both Statement I and Statement II are false

70819168989. Statement I is true but Statement II is false

70819168990. Statement I is false but Statement II is true

**Question Number : 5 Question Id : 70819121278 Question Type : MCQ Option Shuffling : Yes Is**

**Question Mandatory : No**

**Correct Marks : 4 Wrong Marks : 1**

তলত দুটা উক্তি দিয়া আছে :

উক্তি I : এটা ছেকেণ্ডৰ দোলকৰ পৰ্যায়কাল 1 ছেকেণ্ড।

উক্তি II : ই দুয়ো শীৰ্ষ অৱস্থানৰ মাজত দুলিৰৰ বাবে যথার্থভাৱে এক ছেকেণ্ড সময় লয়।

উপৰোক্ত উক্তিৰ প্ৰকাশত, শুদ্ধ উত্তৰ তলৰ বিকল্পৰ পৰা চয়ন কৰা।

**Options :**

70819168987. উক্তি I আৰু উক্তি II দুয়োটাই সঁচা।

70819168988. উক্তি I আৰু উক্তি II দুয়োটাই মিছা।

70819168989. উক্তি I সঁচা কিন্তু উক্তি II মিছা।

70819168990. উক্তি I মিছা কিন্তু উক্তি II সঁচা।

Question Number : 6 Question Id : 70819121279 Question Type : MCQ Option Shuffling : Yes Is

Question Mandatory : No

Correct Marks : 4 Wrong Marks : 1

If 'C' and 'V' represent capacity and voltage respectively then what are the dimensions of  $\lambda$  where  $C/V = \lambda$  ?

Options :

70819168991.  $[M^{-2} L^{-3} I^2 T^6]$

70819168992.  $[M^{-3} L^{-4} I^3 T^7]$

70819168993.  $[M^{-2} L^{-4} I^3 T^7]$

70819168994.  $[M^{-1} L^{-3} I^{-2} T^{-7}]$

Question Number : 6 Question Id : 70819121279 Question Type : MCQ Option Shuffling : Yes Is

Question Mandatory : No

Correct Marks : 4 Wrong Marks : 1

যদি  $C/V = \lambda$  হয়, আৰু 'C' আৰু 'V' য়ে ক্ৰমে ধাৰিতা (capacity) আৰু বিভৱ বুজাইছে, তেন্তে  $\lambda$  ৰ মাত্ৰাবোৰ কি হ'ব ?

Options :

70819168991.  $[M^{-2} L^{-3} I^2 T^6]$

70819168992.  $[M^{-3} L^{-4} I^3 T^7]$

70819168993.  $[M^{-2} L^{-4} I^3 T^7]$

70819168994.  $[M^{-1} L^{-3} I^{-2} T^{-7}]$

Question Number : 7 Question Id : 70819121280 Question Type : MCQ Option Shuffling : Yes Is

Question Mandatory : No

Correct Marks : 4 Wrong Marks : 1

An aeroplane, with its wings spread 10 m, is flying at a speed of 180 km/h in a horizontal direction. The total intensity of earth's field at that part is  $2.5 \times 10^{-4}$  Wb/m<sup>2</sup> and the angle of dip is 60°. The emf induced between the tips of the plane wings will be \_\_\_\_\_.

Options :

70819168995. 108.25 mV

70819168996. 62.50 mV

70819168997. 88.37 mV

70819168998. 54.125 mV

Question Number : 7 Question Id : 70819121280 Question Type : MCQ Option Shuffling : Yes Is

Question Mandatory : No

Correct Marks : 4 Wrong Marks : 1

আনুভূমিক দিশত, 180 km/h দ্রুতিত, পাখিবিস্তাৰ 10 m ৰ এখন এৰ'প্লেনে গতি কৰিছে। সেই অংশত পৃথিৱীৰ ক্ষেত্ৰৰ মুঠ তীব্ৰতা (intensity)  $2.5 \times 10^{-4}$  Wb/m<sup>2</sup> আৰু বিনতি কোণ (angle of dip) 60°। এৰ'প্লেনখনৰ পাখিদুখনৰ শীৰ্ষবিন্দুত আৱেশিত হোৱা বিদ্যুৎ চালক বল হ'ব :

Options :

70819168995. 108.25 mV

70819168996. 62.50 mV

70819168997. 88.37 mV

70819168998. 54.125 mV

Question Number : 8 Question Id : 70819121281 Question Type : MCQ Option Shuffling : Yes Is

Question Mandatory : No

Correct Marks : 4 Wrong Marks : 1

A cord is wound round the circumference of wheel of radius  $r$ . The axis of the wheel is horizontal and the moment of inertia about it is  $I$ . A weight  $mg$  is attached to the cord at the end. The weight falls from rest. After falling through a distance 'h', the square of angular velocity of wheel will be :

Options :

70819168999.  $2gh$

70819169000.  $\frac{2gh}{I + mr^2}$

70819169001.  $\frac{2mgh}{I + mr^2}$

70819169002.  $\frac{2mgh}{I + 2mr^2}$

Question Number : 8 Question Id : 70819121281 Question Type : MCQ Option Shuffling : Yes Is

Question Mandatory : No

Correct Marks : 4 Wrong Marks : 1

$r$  ব্যাসার্ধৰ এটা চকাৰ পৰিধিত এডাল বহী মেৰিওৱা হৈছে। চকাটোৰ অক্ষডাল আনুভূমিক দিশত আছে আৰু অক্ষ সাপেক্ষে ইয়াৰ জড় ভ্ৰামক  $I$ । বহীডালৰ মূৰত এক ওজন  $mg$  সংযোগ কৰা হ'ল। ওজনটো ইয়াৰ স্থিৰ অৱস্থানৰ পৰা সৰি পৰে। 'h' দূৰত্ব সৰি পৰাৰ পাছত, চকাটোৰ কৌণিক বেগৰ বৰ্গ হ'ব :

Options :

70819168999.  $2gh$

70819169000.  $\frac{2gh}{I + mr^2}$

70819169001.

$$\frac{2mgh}{I + mr^2}$$

70819169002.  $\frac{2mgh}{I + 2mr^2}$

**Question Number : 9 Question Id : 70819121282 Question Type : MCQ Option Shuffling : Yes Is Question Mandatory : No**

**Correct Marks : 4 Wrong Marks : 1**

The trajectory of a projectile in a vertical plane is  $y = \alpha x - \beta x^2$ , where  $\alpha$  and  $\beta$  are constants and  $x$  &  $y$  are respectively the horizontal and vertical distances of the projectile from the point of projection. The angle of projection  $\theta$  and the maximum height attained  $H$  are respectively given by :

**Options :**

70819169003.  $\tan^{-1}\beta, \frac{\alpha^2}{2\beta}$

70819169004.  $\tan^{-1}\left(\frac{\beta}{\alpha}\right), \frac{\alpha^2}{\beta}$

70819169005.  $\tan^{-1}\alpha, \frac{\alpha^2}{4\beta}$

70819169006.  $\tan^{-1}\alpha, \frac{4\alpha^2}{\beta}$

**Question Number : 9 Question Id : 70819121282 Question Type : MCQ Option Shuffling : Yes Is Question Mandatory : No**

**Correct Marks : 4 Wrong Marks : 1**

এখন উল্লম্ব তলত এটা পক্ষিপথ পক্ষিপথ পথ  $y = \alpha x - \beta x^2$ , য'ত  $\alpha$  আৰু  $\beta$  ধনাত্মক আৰু  $x, y$  ক্ৰমে পৰিভ্ৰমণ বিন্দুৰ পৰা আনুভূমিক আৰু উল্লম্বদিশত পক্ষিপথটোৰ দূৰত্ব। পক্ষিপথ কোণ  $\theta$  আৰু সৰ্বোচ্চ প্ৰাপ্ত উচ্চতা  $H$  ক্ৰমে,

Options :

70819169003.  $\tan^{-1}\beta, \frac{\alpha^2}{2\beta}$

70819169004.  $\tan^{-1}\left(\frac{\beta}{\alpha}\right), \frac{\alpha^2}{\beta}$

70819169005.  $\tan^{-1}\alpha, \frac{\alpha^2}{4\beta}$

70819169006.  $\tan^{-1}\alpha, \frac{4\alpha^2}{\beta}$

Question Number : 10 Question Id : 70819121283 Question Type : MCQ Option Shuffling : Yes

Is Question Mandatory : No

Correct Marks : 4 Wrong Marks : 1

Two masses A and B, each of mass M are fixed together by a massless spring. A force acts on the mass B as shown in figure. If the mass A starts moving away from mass B with acceleration 'a', then the acceleration of mass B will be :

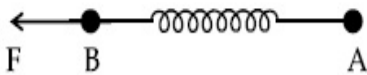

Options :

70819169007.  $\frac{MF}{F + Ma}$

70819169008.  $\frac{F + Ma}{M}$

70819169009.

$$\frac{Ma - F}{M}$$

$$\frac{F - Ma}{M}$$

70819169010.

Question Number : 10 Question Id : 70819121283 Question Type : MCQ Option Shuffling : Yes

Is Question Mandatory : No

Correct Marks : 4 Wrong Marks : 1

এডাল ভৰহীন স্প্ৰিংৰ সহায়ত, প্ৰতিটো  $M$  ভৰৰ দুটা ভৰ  $A$  আৰু  $B$  বান্ধি ৰখা হৈছে। চিত্ৰত দেখুওৱা ধৰণে এটা বলে  $B$  ভৰৰ ওপৰত ক্ৰিয়া কৰি আছে। যদিহে  $A$  ভৰটোৱে  $B$  ভৰটোৰ পৰা 'a' দ্বৰণেৰে আঁতৰলৈ গতি কৰে, তেন্তে  $B$  ভৰটোৰ দ্বৰণ হ'ব,

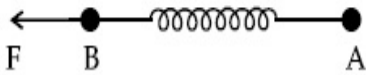

Options :

$$\frac{MF}{F + Ma}$$

70819169007.

$$\frac{F + Ma}{M}$$

70819169008.

$$\frac{Ma - F}{M}$$

70819169009.

$$\frac{F - Ma}{M}$$

70819169010.

Question Number : 11 Question Id : 70819121284 Question Type : MCQ Option Shuffling : Yes

Is Question Mandatory : No

Correct Marks : 4 Wrong Marks : 1

Given below are two statements :

- Statement I : An electric dipole is placed at the centre of a hollow sphere. The flux of electric field through the sphere is zero but the electric field is not zero anywhere in the sphere.
- Statement II : If  $R$  is the radius of a solid metallic sphere and  $Q$  be the total charge on it. The electric field at any point on the spherical surface of radius  $r$  ( $< R$ ) is zero but the electric flux passing through this closed spherical surface of radius  $r$  is not zero.

In the light of the above statements, choose the correct answer from the options given below :

Options :

70819169011. Both Statement I and Statement II are true

70819169012. Both Statement I and Statement II are false

70819169013. Statement I is true but Statement II is false

70819169014. Statement I is false but Statement II is true

Question Number : 11 Question Id : 70819121284 Question Type : MCQ Option Shuffling : Yes

Is Question Mandatory : No

Correct Marks : 4 Wrong Marks : 1

তলত দুটা উক্তি দিয়া আছে :

- উক্তি I : এটা ফোঁপোলা গোলকৰ কেন্দ্ৰত এটা বৈদ্যুতিক দ্বিমেরু বখা হৈছে। গোলকটোৰ মাজেদি বিদ্যুৎক্ষেত্রৰ অভিবাহ (flux) শূন্য, কিন্তু গোলকটোৰ ক'তোৰেই বিদ্যুৎক্ষেত্র শূন্য নহয়।
- উক্তি II : ধৰা হ'ল এটা গোটা ধাতুৰ গোলকৰ ব্যাসার্ধ  $R$  আৰু ইয়াত থকা মুঠ আধানৰ পৰিমাণ  $Q$ ।  $r$  ( $< R$ ) ব্যাসার্ধৰ গোলাকাৰ পৃষ্ঠৰ যিকোনো বিন্দুত বিদ্যুৎ ক্ষেত্র শূন্য হ'ব, কিন্তু  $r$  ব্যাসার্ধৰ এই বন্ধ (closed) গোলাকাৰ পৃষ্ঠৰ মাজেদি পৰা হোৱা বিদ্যুৎ ক্ষেত্রৰ অভিবাহ (electric flux) শূন্য নহয়।

উপৰোক্ত দুই উক্তিৰ প্ৰকাশত, তলৰ বিকল্পৰ পৰা শুদ্ধ উত্তৰ চয়ন কৰা।

Options :

70819169011. উক্তি I আৰু উক্তি II দুয়োটাই সঁচা।

70819169012. উক্তি I আৰু উক্তি II দুয়োটাই মিছা।

70819169013. উক্তি I সঁচা কিন্তু উক্তি II মিছা।

70819169014. উক্তি I মিছা কিন্তু উক্তি II সঁচা।

Question Number : 12 Question Id : 70819121285 Question Type : MCQ Option Shuffling : Yes

Is Question Mandatory : No

Correct Marks : 4 Wrong Marks : 1

A scooter accelerates from rest for time  $t_1$  at constant rate  $a_1$  and then retards at constant rate  $a_2$  for time  $t_2$  and comes to rest. The correct value of  $\frac{t_1}{t_2}$  will be :

Options :

70819169015.  $\frac{a_1}{a_2}$

70819169016.  $\frac{a_2}{a_1}$

70819169017.  $\frac{a_1 + a_2}{a_1}$

70819169018.  $\frac{a_1 + a_2}{a_2}$

Question Number : 12 Question Id : 70819121285 Question Type : MCQ Option Shuffling : Yes

Is Question Mandatory : No

Correct Marks : 4 Wrong Marks : 1

এখন স্কুটাৰ  $t_1$  সময়ৰ বাবে  $a_1$  সুষম হাবত ছিৰ অৱস্থাৰ পৰা ত্বৰান্বিত হয় আৰু তাৰ পাছত  $t_2$  সময়ৰ বাবে  $a_2$  সুষম

হাবত মন্থৰণ হৈ ছিৰ অৱস্থা প্ৰাপ্ত হয়।  $\frac{t_1}{t_2}$  ৰ শুদ্ধ মান হ'ব :

**Options :**

70819169015.  $\frac{a_1}{a_2}$

70819169016.  $\frac{a_2}{a_1}$

70819169017.  $\frac{a_1 + a_2}{a_1}$

70819169018.  $\frac{a_1 + a_2}{a_2}$

**Question Number : 13 Question Id : 70819121286 Question Type : MCQ Option Shuffling : Yes**

**Is Question Mandatory : No**

**Correct Marks : 4 Wrong Marks : 1**

The internal energy (U), pressure (P) and volume (V) of an ideal gas are related as  $U = 3PV + 4$ .

The gas is :

**Options :**

70819169019. monoatomic only.

70819169020. diatomic only.

70819169021. polyatomic only.

70819169022. either monoatomic or diatomic.

Question Number : 13 Question Id : 70819121286 Question Type : MCQ Option Shuffling : Yes

Is Question Mandatory : No

Correct Marks : 4 Wrong Marks : 1

এটা আদৰ্শ গেছৰ ক্ষেত্ৰত, আভ্যন্তৰীণ শক্তি (U), চাপ (P) আৰু আয়তন (V) ৰ মাজত সম্বন্ধ  $U=3PV+4$ ।  
গেছটো :

Options :

70819169019. এক-পাৰমাণৱিক গেছ।

70819169020. দ্বি-পাৰমাণৱিক গেছ।

70819169021. বহু পাৰমাণৱিক গেছ।

70819169022. এক-পাৰমাণৱিক অথবা দ্বি-পাৰমাণৱিক।

Question Number : 14 Question Id : 70819121287 Question Type : MCQ Option Shuffling : Yes

Is Question Mandatory : No

Correct Marks : 4 Wrong Marks : 1

The recoil speed of a hydrogen atom after it emits a photon in going from  $n=5$  state to  $n=1$  state will be :

Options :

70819169023. 4.34 m/s

70819169024. 4.17 m/s

70819169025. 3.25 m/s

70819169026. 2.19 m/s

Question Number : 14 Question Id : 70819121287 Question Type : MCQ Option Shuffling : Yes

Is Question Mandatory : No

Correct Marks : 4 Wrong Marks : 1

ফ'ট'ন এটা নিৰ্গত কৰাৰ পাছত, হাইড্ৰ'জেন পৰমাণু এটাই  $n=5$  স্তৰৰ পৰা  $n=1$  স্তৰলৈ গতি কৰোতে ইয়াৰ  
প্ৰত্যাহাতি (recoil) দ্ৰুতি হ'ব :

Options :

70819169023. 4.34 m/s

70819169024. 4.17 m/s

70819169025. 3.25 m/s

70819169026. 2.19 m/s

Question Number : 15 Question Id : 70819121288 Question Type : MCQ Option Shuffling : Yes

Is Question Mandatory : No

Correct Marks : 4 Wrong Marks : 1

The length of metallic wire is  $l_1$  when tension in it is  $T_1$ . It is  $l_2$  when the tension is  $T_2$ . The  
original length of the wire will be :

Options :

70819169027.  $\frac{l_1 + l_2}{2}$

70819169028.  $\frac{T_2 l_1 + T_1 l_2}{T_1 + T_2}$

70819169029.  $\frac{T_1 l_1 - T_2 l_2}{T_2 - T_1}$

70819169030. 
$$\frac{T_2 l_1 - T_1 l_2}{T_2 - T_1}$$

**Question Number : 15 Question Id : 70819121288 Question Type : MCQ Option Shuffling : Yes  
Is Question Mandatory : No**

**Correct Marks : 4 Wrong Marks : 1**

যেতিয়া টান  $T_1$  হয়, এডাল খাতুৰ তাঁৰৰ দৈৰ্ঘ্য  $l_1$  হয়। যেতিয়া টান  $T_2$  হয়, দৈৰ্ঘ্য  $l_2$  হয়। তাঁৰডালৰ প্ৰকৃত দৈৰ্ঘ্য হ'ব :

**Options :**

70819169027. 
$$\frac{l_1 + l_2}{2}$$

70819169028. 
$$\frac{T_2 l_1 + T_1 l_2}{T_1 + T_2}$$

70819169029. 
$$\frac{T_1 l_1 - T_2 l_2}{T_2 - T_1}$$

70819169030. 
$$\frac{T_2 l_1 - T_1 l_2}{T_2 - T_1}$$

**Question Number : 16 Question Id : 70819121289 Question Type : MCQ Option Shuffling : Yes  
Is Question Mandatory : No**

**Correct Marks : 4 Wrong Marks : 1**

A particle executes S.H.M., the graph of velocity as a function of displacement is :

**Options :**

70819169031. a circle.

70819169032. a parabola.

70819169033. an ellipse.

70819169034. a helix.

**Question Number : 16 Question Id : 70819121289 Question Type : MCQ Option Shuffling : Yes**

**Is Question Mandatory : No**

**Correct Marks : 4 Wrong Marks : 1**

এটা কণাই সৰল পৰ্যাবৃত্ত গতি দৰ্শাইছে। সৰণৰ ফলন হিচাপে বেগৰ লেখচিত্ৰ হ'ব :

**Options :**

70819169031. এটা বৃত্ত

70819169032. এটা অধিবৃত্ত

70819169033. এটা উপবৃত্ত

70819169034. এটা হেলিক্স (helix)

**Question Number : 17 Question Id : 70819121290 Question Type : MCQ Option Shuffling : Yes**

**Is Question Mandatory : No**

**Correct Marks : 4 Wrong Marks : 1**

The incident ray, reflected ray and the outward drawn normal are denoted by the unit

vectors  $\vec{a}$ ,  $\vec{b}$  and  $\vec{c}$  respectively. Then choose the correct relation for these vectors.

**Options :**

70819169035.  $\vec{b} = \vec{a} - \vec{c}$

70819169036.  $\vec{b} = \vec{a} - 2(\vec{a} \cdot \vec{c})\vec{c}$

70819169037.  $\vec{b} = \vec{a} + 2\vec{c}$

70819169038.  $\vec{b} = 2\vec{a} + \vec{c}$

Question Number : 17 Question Id : 70819121290 Question Type : MCQ Option Shuffling : Yes

Is Question Mandatory : No

Correct Marks : 4 Wrong Marks : 1

একক ভেক্টর  $\vec{a}$ ,  $\vec{b}$  আৰু  $\vec{c}$  য়ে ক্ৰমে আপতিত বশ্মি, প্রতিফলিত বশ্মি আৰু বহির্দিশত টনা লম্বক সূচাইছে। এই ভেক্টৰ সমূহৰ মাজৰ শুদ্ধ সম্পর্ক চয়ন কৰা।

Options :

70819169035.  $\vec{b} = \vec{a} - \vec{c}$

70819169036.  $\vec{b} = \vec{a} - 2(\vec{a} \cdot \vec{c})\vec{c}$

70819169037.  $\vec{b} = \vec{a} + 2\vec{c}$

70819169038.  $\vec{b} = 2\vec{a} + \vec{c}$

Question Number : 18 Question Id : 70819121291 Question Type : MCQ Option Shuffling : Yes

Is Question Mandatory : No

Correct Marks : 4 Wrong Marks : 1

Find the peak current and resonant frequency of the following circuit (as shown in figure).

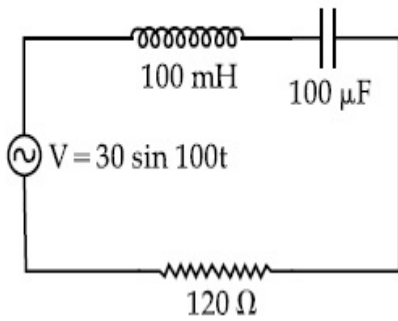

Options :

70819169039. 2 A and 50 Hz

70819169040. 0.2 A and 50 Hz

70819169041. 2 A and 100 Hz

70819169042. 0.2 A and 100 Hz

Question Number : 18 Question Id : 70819121291 Question Type : MCQ Option Shuffling : Yes

Is Question Mandatory : No

Correct Marks : 4 Wrong Marks : 1

চিত্রত দেখুওৱা বৰ্তনীটোৰ বাবে সৰ্বোচ্চ বিদ্যুৎৰ (Peak current) মান আৰু অনুনাদ কম্পনাংক নিৰ্ণয় কৰা।

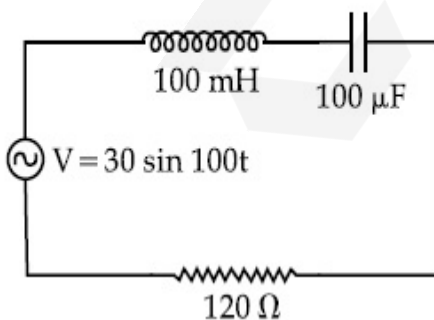

Options :

70819169039. 2 A আৰু 50 Hz

70819169040. 0.2 A আৰু 50 Hz

70819169041. 2 A আৰু 100 Hz

70819169042. 0.2 A আৰু 100 Hz

**Question Number : 19 Question Id : 70819121292 Question Type : MCQ Option Shuffling : Yes  
Is Question Mandatory : No**

**Correct Marks : 4 Wrong Marks : 1**

An inclined plane making an angle of  $30^\circ$  with the horizontal is placed in a uniform horizontal electric field  $200 \frac{\text{N}}{\text{C}}$  as shown in the figure. A body of mass 1 kg and charge 5 mC is allowed to slide down from rest at a height of 1 m. If the coefficient of friction is 0.2, find the time taken by the body to reach the bottom.

$$[g = 9.8 \text{ m/s}^2; \sin 30^\circ = \frac{1}{2}; \cos 30^\circ = \frac{\sqrt{3}}{2}]$$

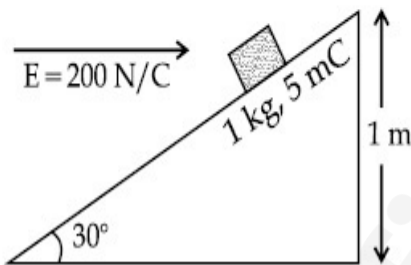

**Options :**

70819169043. 2.3 s

70819169044. 1.3 s

70819169045. 0.92 s

70819169046. 0.46 s

Question Number : 19 Question Id : 70819121292 Question Type : MCQ Option Shuffling : Yes

Is Question Mandatory : No

Correct Marks : 4 Wrong Marks : 1

চিত্রত দেখুওৱা ধৰণে,  $200 \frac{N}{C}$  ৰ এখন আনুভূমিক সুযম বিদ্যুৎ ক্ষেত্ৰত, আনুভূমিক দিশৰ লগত  $30^\circ$  কোণত হেলনীয়া

হৈ থকা এখন তল ৰখা হৈছে। তলখনত  $5 \text{ mC}$  আধানযুক্ত আৰু  $1 \text{ kg}$  ভৰৰ এটা বস্তু  $1 \text{ m}$  উচ্চতাৰ স্থিৰ অৱস্থাৰ পৰা পিছলি আহিবলৈ দিয়া হৈছে। ঘৰ্ষণ গুণাংক যদিহে  $0.2$  হয়, বস্তুটো বাগৰি আহি তল পাবলৈ লগা সময় উলিওৱা।

$$[g = 9.8 \text{ m/s}^2; \sin 30^\circ = \frac{1}{2}; \cos 30^\circ = \frac{\sqrt{3}}{2}]$$

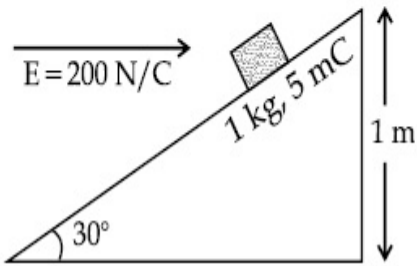

Options :

70819169043. 2.3 s

70819169044. 1.3 s

70819169045. 0.92 s

70819169046. 0.46 s

Question Number : 20 Question Id : 70819121293 Question Type : MCQ Option Shuffling : Yes

Is Question Mandatory : No

Correct Marks : 4 Wrong Marks : 1

A wire of  $1 \Omega$  has a length of  $1 \text{ m}$ . It is stretched till its length increases by  $25\%$ . The percentage change in resistance to the nearest integer is :

Options :

70819169047. 76 %

70819169048. 56%

70819169049. 25%

70819169050. 12.5%

**Question Number : 20 Question Id : 70819121293 Question Type : MCQ Option Shuffling : Yes  
Is Question Mandatory : No**

**Correct Marks : 4 Wrong Marks : 1**

এডাল  $1\ \Omega$  ৰ তাঁৰৰ দৈৰ্ঘ্য  $1\ \text{m}$ । ইয়াক ইয়াৰ দৈৰ্ঘ্য 25% হোৱালৈকে টনা হ'ল। ইয়াৰ ৰোধকৰ পৰিবৰ্তনৰ নিকটতম  
পূৰ্ণসংখ্যাৰ শতাংশ :

**Options :**

70819169047. 76%

70819169048. 56%

70819169049. 25%

70819169050. 12.5%

## Physics Section B

|                                |           |
|--------------------------------|-----------|
| <b>Section Id :</b>            | 708191959 |
| <b>Section Number :</b>        | 2         |
| <b>Section type :</b>          | Online    |
| <b>Mandatory or Optional :</b> | Mandatory |
| <b>Number of Questions :</b>   | 10        |

Number of Questions to be attempted : 5  
Section Marks : 20  
Mark As Answered Required? : Yes  
Sub-Section Number : 1  
Sub-Section Id : 7081911239  
Question Shuffling Allowed : Yes

Question Number : 21 Question Id : 70819121294 Question Type : SA

Correct Marks : 4 Wrong Marks : 0

The zener diode has a  $V_z = 30$  V. The current passing through the diode for the following circuit is \_\_\_\_\_ mA.

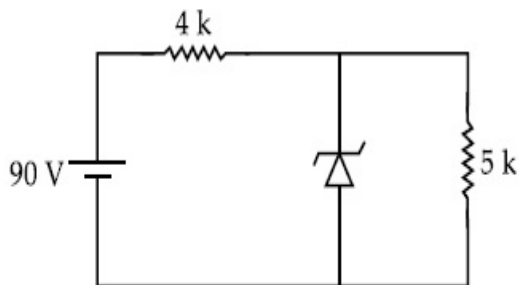

Response Type : Numeric

Evaluation Required For SA : Yes

Show Word Count : Yes

Answers Type : Range

Text Areas : PlainText

Possible Answers :

5 to 5.001

Question Number : 21 Question Id : 70819121294 Question Type : SA

Correct Marks : 4 Wrong Marks : 0

এটা জেনাৰ ডায়'ডৰ  $V_z = 30\text{ V}$ । তলত দিয়া বৰ্তনীত, ডায়ডটোৰ মাজেদি পাৰ হোৱা

\_\_\_\_\_ mA।

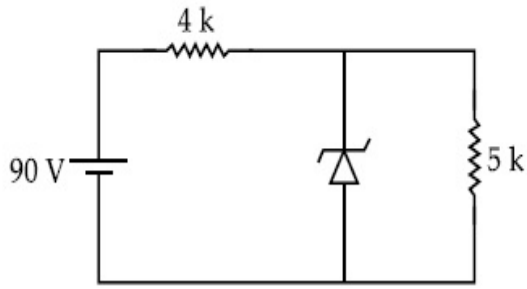

**Response Type :** Numeric

**Evaluation Required For SA :** Yes

**Show Word Count :** Yes

**Answers Type :** Range

**Text Areas :** PlainText

**Possible Answers :**

5 to 5.001

**Question Number :** 22 **Question Id :** 70819121295 **Question Type :** SA

**Correct Marks :** 4 **Wrong Marks :** 0

Time period of a simple pendulum is  $T$ . The time taken to complete  $\frac{5}{8}$  oscillations starting

from mean position is  $\frac{\alpha}{\beta}T$ . The value of  $\alpha$  is \_\_\_\_\_.

**Response Type :** Numeric

**Evaluation Required For SA :** Yes

**Show Word Count :** Yes

**Answers Type :** Range

**Text Areas :** PlainText

**Possible Answers :**

5 to 5.001

**Question Number :** 22 **Question Id :** 70819121295 **Question Type :** SA

**Correct Marks :** 4 **Wrong Marks :** 0

সবল দোলক এটাৰ পৰ্যায়কাল  $T$ । মাধ্য অৱস্থানৰ পৰা আৰম্ভ কৰি  $\frac{5}{8}$  সংখ্যক দোলন সম্পূৰ্ণ কৰিবৰ বাবে লগা সময়

$\frac{\alpha}{\beta}T$ ।  $\alpha$  ৰ মান হ'ব \_\_\_\_\_।

**Response Type :** Numeric

**Evaluation Required For SA :** Yes

**Show Word Count :** Yes

**Answers Type :** Range

**Text Areas :** PlainText

**Possible Answers :**

5 to 5.001

**Question Number :** 23 **Question Id :** 70819121296 **Question Type :** SA

**Correct Marks :** 4 **Wrong Marks :** 0

The volume  $V$  of a given mass of monoatomic gas changes with temperature  $T$  according to

the relation  $V = KT^{\frac{2}{3}}$ . The workdone when temperature changes by 90 K will be  $xR$ . The value of  $x$  is \_\_\_\_\_.

[ $R$  = universal gas constant]

**Response Type :** Numeric

**Evaluation Required For SA :** Yes

**Show Word Count :** Yes

**Answers Type :** Range

**Text Areas :** PlainText

**Possible Answers :**

5 to 5.001

**Question Number :** 23 **Question Id :** 70819121296 **Question Type :** SA

**Correct Marks :** 4 **Wrong Marks :** 0

এটা এক পাৰমাণৱিক গেছৰ আয়তন  $V$  উষ্ণতা  $T$  ৰ সৈতে  $V = KT^{\frac{2}{3}}$  সম্বন্ধ অনুসৰি সলনি হয়। উষ্ণতা  $90\text{ K}$  সলনিৰ বাবে সম্পাদিত কাৰ্য্য  $xR$ ,  $x$  ৰ মান \_\_\_\_\_।

[ $R =$  বিশ্বজনীন গেছ ধ্ৰুৱক]

**Response Type :** Numeric

**Evaluation Required For SA :** Yes

**Show Word Count :** Yes

**Answers Type :** Range

**Text Areas :** PlainText

**Possible Answers :**

5 to 5.001

**Question Number :** 24 **Question Id :** 70819121297 **Question Type :** SA

**Correct Marks :** 4 **Wrong Marks :** 0

Two stream of photons, possessing energies equal to twice and ten times the work function of metal are incident on the metal surface successively. The value of ratio of maximum velocities of the photoelectrons emitted in the two respective cases is  $x : y$ . The value of  $x$  is \_\_\_\_\_.

**Response Type :** Numeric

**Evaluation Required For SA :** Yes

**Show Word Count :** Yes

**Answers Type :** Range

**Text Areas :** PlainText

**Possible Answers :**

5 to 5.001

**Question Number :** 24 **Question Id :** 70819121297 **Question Type :** SA

**Correct Marks :** 4 **Wrong Marks :** 0

এটা ধাতুৰ কাৰ্য ফলনৰ ক্ৰমে দুগুণ আৰু দহগুণ বেছি শক্তিৰ দুটা ফ'ট'নৰ ধাৰা ধাতুৰ পৃষ্ঠত ক্ৰমানুসৰি আপতিত হৈছে। দুয়ো ক্ষেত্ৰত নিৰ্গত ফ'ট'ইলেকট্ৰনৰ সৰ্বোচ্চ বেগৰ অনুপাত  $x : y$ ।  $x$  ৰ মান \_\_\_\_\_।

**Response Type :** Numeric

**Evaluation Required For SA :** Yes

Show Word Count : Yes

Answers Type : Range

Text Areas : PlainText

Possible Answers :

5 to 5.001

Question Number : 25 Question Id : 70819121298 Question Type : SA

Correct Marks : 4 Wrong Marks : 0

If the highest frequency modulating a carrier is 5 kHz, then the number of AM broadcast stations accommodated in a 90 kHz bandwidth are \_\_\_\_\_.

Response Type : Numeric

Evaluation Required For SA : Yes

Show Word Count : Yes

Answers Type : Range

Text Areas : PlainText

Possible Answers :

5 to 5.001

Question Number : 25 Question Id : 70819121298 Question Type : SA

Correct Marks : 4 Wrong Marks : 0

যদিহে এটা বাহকক কলন কৰা সবেৰ্বাচ্চ কম্পনাংক 5 kHz হয়, তেন্তে 90 kHz পটিবেধৰ অন্তৰ্গত বিস্তাৰ কলন সম্প্ৰচাৰ ষ্টেচনৰ অনুমোদিত সংখ্যা হ'ল \_\_\_\_\_ ।

Response Type : Numeric

Evaluation Required For SA : Yes

Show Word Count : Yes

Answers Type : Range

Text Areas : PlainText

Possible Answers :

5 to 5.001

Correct Marks : 4 Wrong Marks : 0

In the reported figure of earth, the value of acceleration due to gravity is same at point A and C but it is smaller than that of its value at point B (surface of the earth). The value of  $OA : AB$  will be  $x : y$ . The value of  $x$  is \_\_\_\_\_.

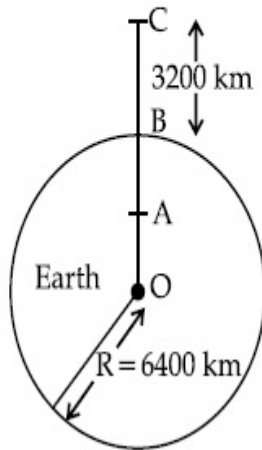

Response Type : Numeric

Evaluation Required For SA : Yes

Show Word Count : Yes

Answers Type : Range

Text Areas : PlainText

Possible Answers :

5 to 5.001

Question Number : 26 Question Id : 70819121299 Question Type : SA

Correct Marks : 4 Wrong Marks : 0

চিত্রত দেখিওৱা অনুসৰি, মধ্যাকৰ্ষণিক ত্বৰণৰ মান, বিন্দু A আৰু বিন্দু C ত একেই, কিন্তু বিন্দু B (পৃষ্ঠত) ত ইয়াৰ মানতকৈ কম।

OA : AB ৰ মান হ'ব  $x : y$ ।  $x$  ৰ মান হয় \_\_\_\_\_।

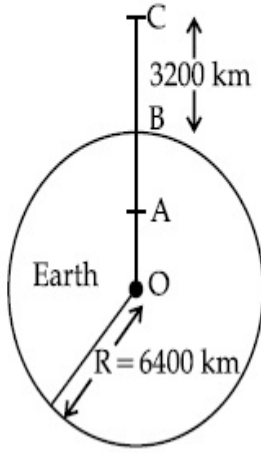

**Response Type :** Numeric

**Evaluation Required For SA :** Yes

**Show Word Count :** Yes

**Answers Type :** Range

**Text Areas :** PlainText

**Possible Answers :**

5 to 5.001

**Question Number :** 27 **Question Id :** 70819121300 **Question Type :** SA

**Correct Marks :** 4 **Wrong Marks :** 0

1 mole of rigid diatomic gas performs a work of  $\frac{Q}{5}$  when heat  $Q$  is supplied to it. The molar

heat capacity of the gas during this transformation is  $\frac{xR}{8}$ . The value of  $x$  is \_\_\_\_\_.

[ $R$  = universal gas constant]

**Response Type :** Numeric

**Evaluation Required For SA :** Yes

**Show Word Count :** Yes

**Answers Type :** Range

**Text Areas :** PlainText

**Possible Answers :**

Question Number : 27 Question Id : 70819121300 Question Type : SA

Correct Marks : 4 Wrong Marks : 0

যেতিয়া Q পৰিমাণৰ তাপ যোগান ধৰা হয়, 1 ম'ল পৰিমাণৰ এক দৃঢ় দ্বি-পাৰমাণৱিক গেছে  $\frac{Q}{5}$  পৰিমাণৰ কাৰ্য সম্পাদন

কৰে। এই পৰিবৰ্তনৰ সময়ত গেছটোৰ ম'লাৰ তাপধৃতি হ'ব  $\frac{xR}{8}$ ।  $x$  ৰ মান \_\_\_\_\_।

[R = বিশ্বজনীন গেছ ধ্ৰুৱক]

Response Type : Numeric

Evaluation Required For SA : Yes

Show Word Count : Yes

Answers Type : Range

Text Areas : PlainText

Possible Answers :

5 to 5.001

Question Number : 28 Question Id : 70819121301 Question Type : SA

Correct Marks : 4 Wrong Marks : 0

A point source of light S, placed at a distance 60 cm in front of the centre of a plane mirror of width 50 cm, hangs vertically on a wall. A man walks in front of the mirror along a line parallel to the mirror at a distance 1.2 m from it (see in the figure). The distance between the extreme points where he can see the image of the light source in the mirror is \_\_\_\_\_ cm.

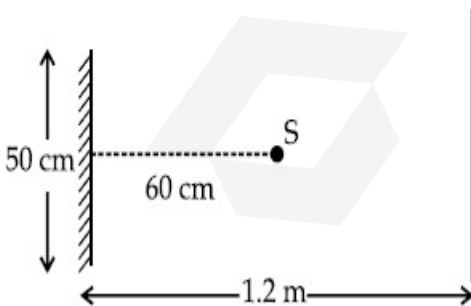

Response Type : Numeric

Evaluation Required For SA : Yes

Show Word Count : Yes

Answers Type : Range

Text Areas : PlainText

Possible Answers :

5 to 5.001

Question Number : 28 Question Id : 70819121301 Question Type : SA

Correct Marks : 4 Wrong Marks : 0

উল্লম্বদিশত ওলোমাই বখা এটা পোহৰৰ বিন্দু উৎস S, 50 cm বহল এখন সমতল দাপোণৰ কেন্দ্ৰৰ পৰা 60 cm দূৰত্বত অৱস্থিত। সমতল দাপোণখনৰ সম্মুখত, ইয়াৰ পৰা 1.2 m দূৰত্বত, দাপোণৰ সমান্তৰাল এডাল বেখাৰ দিশত এজন মানুহে খোজ কাঢ়িছে (চিত্ৰত চোৱা)। মানুহজনে দাপোণত পোহৰ উৎসৰ প্ৰতিবিন্দু দেখাপোৱাৰ চৰম (extreme) বিন্দু দুটাৰ মাজৰ দূৰত্ব \_\_\_\_\_ cm।

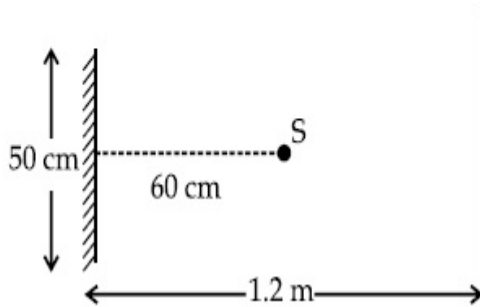

Response Type : Numeric

Evaluation Required For SA : Yes

Show Word Count : Yes

Answers Type : Range

Text Areas : PlainText

Possible Answers :

5 to 5.001

Question Number : 29 Question Id : 70819121302 Question Type : SA

Correct Marks : 4 Wrong Marks : 0

A particle executes S.H.M. with amplitude 'a' and time period 'T'. The displacement of the particle when its speed is half of maximum speed is  $\frac{\sqrt{x}a}{2}$ . The value of x is \_\_\_\_\_.

Response Type : Numeric

Evaluation Required For SA : Yes

Show Word Count : Yes

**Answers Type :** Range

**Text Areas :** PlainText

**Possible Answers :**

5 to 5.001

**Question Number : 29 Question Id : 70819121302 Question Type : SA**

**Correct Marks : 4 Wrong Marks : 0**

এটা কণাই 'a' বিস্তাৰ আৰু পৰ্যায়কাল 'T' সহিতে সৰল পৰ্যাবৃত্ত গতিত গতি কৰিছে। যেতিয়া ইয়াৰ দ্ৰুতি সৰ্বোচ্চ দ্ৰুতিৰ

আধা হয় তেতিয়া ইয়াৰ সৰণ হয়  $\frac{\sqrt{x}a}{2}$ । x ৰ মান হ'ব \_\_\_\_\_।

**Response Type :** Numeric

**Evaluation Required For SA :** Yes

**Show Word Count :** Yes

**Answers Type :** Range

**Text Areas :** PlainText

**Possible Answers :**

5 to 5.001

**Question Number : 30 Question Id : 70819121303 Question Type : SA**

**Correct Marks : 4 Wrong Marks : 0**

27 similar drops of mercury are maintained at 10 V each. All these spherical drops combine into a single big drop. The potential energy of the bigger drop is \_\_\_\_\_ times that of a smaller drop.

**Response Type :** Numeric

**Evaluation Required For SA :** Yes

**Show Word Count :** Yes

**Answers Type :** Range

**Text Areas :** PlainText

**Possible Answers :**

5 to 5.001

Question Number : 30 Question Id : 70819121303 Question Type : SA

Correct Marks : 4 Wrong Marks : 0

27 টা একেই পাৰাৰ টোপালৰ প্ৰতিটোকে 10 V বিভৱত ৰখা হৈছে। সকলোবোৰ গোলাকাৰ টোপাল লগলগাই এটা ডাঙৰ টোপাল সৃষ্টি কৰা হৈছে। ডাঙৰ টোপালটোৰ স্থিতি শক্তি এটা সৰু টোপালৰ \_\_\_\_\_ গুণ হ'ব।

Response Type : Numeric

Evaluation Required For SA : Yes

Show Word Count : Yes

Answers Type : Range

Text Areas : PlainText

Possible Answers :

5 to 5.001

## Chemistry Section A

|                                       |            |
|---------------------------------------|------------|
| Section Id :                          | 708191960  |
| Section Number :                      | 3          |
| Section type :                        | Online     |
| Mandatory or Optional :               | Mandatory  |
| Number of Questions :                 | 20         |
| Number of Questions to be attempted : | 20         |
| Section Marks :                       | 80         |
| Mark As Answered Required? :          | Yes        |
| Sub-Section Number :                  | 1          |
| Sub-Section Id :                      | 7081911240 |
| Question Shuffling Allowed :          | Yes        |

Question Number : 31 Question Id : 70819121304 Question Type : MCQ Option Shuffling : Yes

Is Question Mandatory : No

Correct Marks : 4 Wrong Marks : 1

Match List-I with List-II.

| List-I<br>(Molecule) | List-II<br>(Bond order) |
|----------------------|-------------------------|
| (a) Ne <sub>2</sub>  | (i) 1                   |
| (b) N <sub>2</sub>   | (ii) 2                  |
| (c) F <sub>2</sub>   | (iii) 0                 |
| (d) O <sub>2</sub>   | (iv) 3                  |

Choose the correct answer from the options given below :

**Options :**

70819169061. (a) → (i), (b) → (ii), (c) → (iii), (d) → (iv)

70819169062. (a) → (iv), (b) → (iii), (c) → (ii), (d) → (i)

70819169063. (a) → (ii), (b) → (i), (c) → (iv), (d) → (iii)

70819169064. (a) → (iii), (b) → (iv), (c) → (i), (d) → (ii)

**Question Number : 31 Question Id : 70819121304 Question Type : MCQ Option Shuffling : Yes**

**Is Question Mandatory : No**

**Correct Marks : 4 Wrong Marks : 1**

তালিকা-I ক তালিকা-II ৰ সৈতে মিলোৱা :

| তালিকা-I<br>(অণু)   | তালিকা-II<br>(বান্ধনি ক্ৰম) |
|---------------------|-----------------------------|
| (a) Ne <sub>2</sub> | (i) 1                       |
| (b) N <sub>2</sub>  | (ii) 2                      |
| (c) F <sub>2</sub>  | (iii) 0                     |
| (d) O <sub>2</sub>  | (iv) 3                      |

তলত দিয়া বিকল্পবোৰৰ পৰা শুদ্ধ উত্তৰটো বাছি উলিওৱা :

**Options :**

70819169061. (a) → (i), (b) → (ii), (c) → (iii), (d) → (iv)

70819169062. (a) → (iv), (b) → (iii), (c) → (ii), (d) → (i)

70819169063. (a) → (ii), (b) → (i), (c) → (iv), (d) → (iii)

70819169064. (a) → (iii), (b) → (iv), (c) → (i), (d) → (ii)

**Question Number : 32 Question Id : 70819121305 Question Type : MCQ Option Shuffling : Yes**

**Is Question Mandatory : No**

**Correct Marks : 4 Wrong Marks : 1**

The nature of charge on resulting colloidal particles when  $\text{FeCl}_3$  is added to excess of hot water is :

**Options :**

70819169065. positive

70819169066. negative

70819169067. neutral

70819169068. sometimes positive and sometimes negative

**Question Number : 32 Question Id : 70819121305 Question Type : MCQ Option Shuffling : Yes**

**Is Question Mandatory : No**

**Correct Marks : 4 Wrong Marks : 1**

যেতিয়া অধিক পৰিমাণৰ গৰম পানীত  $\text{FeCl}_3$  যোগ কৰা হয়, গঠন হোৱা কলয়ডৰ আধানৰ প্ৰকৃতি হ'ল :

**Options :**

70819169065. ধনাত্মক

70819169066. ঋণাত্মক

70819169067. প্ৰশম

70819169068. কেতিয়াবা ধনাত্মক আৰু কেতিয়াবা ঋণাত্মক

**Question Number : 33 Question Id : 70819121306 Question Type : MCQ Option Shuffling : Yes  
Is Question Mandatory : No**

**Correct Marks : 4 Wrong Marks : 1**

The correct order of electron gain enthalpy is :

**Options :**

70819169069.  $O > S > Se > Te$

70819169070.  $Te > Se > S > O$

70819169071.  $S > O > Se > Te$

70819169072.  $S > Se > Te > O$

**Question Number : 33 Question Id : 70819121306 Question Type : MCQ Option Shuffling : Yes  
Is Question Mandatory : No**

**Correct Marks : 4 Wrong Marks : 1**

ইলেক্ট্রন গ্রহণ এন্থালপির শুদ্ধ ক্রম হ'ল :

**Options :**

70819169069.  $O > S > Se > Te$

70819169070.  $Te > Se > S > O$

70819169071.  $S > O > Se > Te$

70819169072.  $S > Se > Te > O$

**Question Number : 34 Question Id : 70819121307 Question Type : MCQ Option Shuffling : Yes**

Is Question Mandatory : No

Correct Marks : 4 Wrong Marks : 1

Match List-I with List-II.

| List-I        | List-II  |
|---------------|----------|
| (a) Siderite  | (i) Cu   |
| (b) Calamine  | (ii) Ca  |
| (c) Malachite | (iii) Fe |
| (d) Cryolite  | (iv) Al  |
|               | (v) Zn   |

Choose the correct answer from the options given below :

Options :

70819169073. (a) → (i), (b) → (ii), (c) → (v), (d) → (iii)

70819169074. (a) → (iii), (b) → (v), (c) → (i), (d) → (iv)

70819169075. (a) → (i), (b) → (ii), (c) → (iii), (d) → (iv)

70819169076. (a) → (iii), (b) → (i), (c) → (v), (d) → (ii)

Question Number : 34 Question Id : 70819121307 Question Type : MCQ Option Shuffling : Yes

Is Question Mandatory : No

Correct Marks : 4 Wrong Marks : 1

তালিকা-I ক তালিকা-II ৰ লগত মিলোৱা :

| তালিকা-I        | তালিকা-II |
|-----------------|-----------|
| (a) চিডেৰাইট    | (i) Cu    |
| (b) কেলামাইন    | (ii) Ca   |
| (c) মেলাকাইট    | (iii) Fe  |
| (d) ক্ৰায়'লাইট | (iv) Al   |
|                 | (v) Zn    |

তলত দিয়া বিকল্পবোৰৰ পৰা শুদ্ধ উত্তৰটো বাছি উলিওৱা :

Options :

70819169073. (a) → (i), (b) → (ii), (c) → (v), (d) → (iii)

70819169074. (a) → (iii), (b) → (v), (c) → (i), (d) → (iv)

70819169075. (a) → (i), (b) → (ii), (c) → (iii), (d) → (iv)

70819169076. (a) → (iii), (b) → (i), (c) → (v), (d) → (ii)

Question Number : 35 Question Id : 70819121308 Question Type : MCQ Option Shuffling : Yes

Is Question Mandatory : No

Correct Marks : 4 Wrong Marks : 1

Which of the following forms of hydrogen emits low energy  $\beta^-$  particles ?

Options :

70819169077. Proton  $H^+$

70819169078. Protium  ${}^1_1H$

70819169079. Deuterium  ${}^2_1H$

70819169080. Tritium  ${}^3_1H$

Question Number : 35 Question Id : 70819121308 Question Type : MCQ Option Shuffling : Yes

Is Question Mandatory : No

Correct Marks : 4 Wrong Marks : 1

তলত দিয়া হাইড্ৰ'জেনৰ ৰূপবোৰৰ কোনটোৱে নিম্ন শক্তি  $\beta^-$  কণা নিৰ্গত কৰে ?

Options :

70819169077. প্ৰ'টন  $H^+$

70819169078. প্ৰ'টিয়াম  ${}^1_1H$

70819169079. ডিউটেৰিয়াম  ${}^2_1\text{H}$

70819169080. ট্ৰিটিয়াম  ${}^3_1\text{H}$

Question Number : 36 Question Id : 70819121309 Question Type : MCQ Option Shuffling : Yes

Is Question Mandatory : No

Correct Marks : 4 Wrong Marks : 1

Match List-I with List-II.

| List-I               | List-II              |
|----------------------|----------------------|
| (a) Sodium Carbonate | (i) Deacon           |
| (b) Titanium         | (ii) Castner-Kellner |
| (c) Chlorine         | (iii) van-Arkel      |
| (d) Sodium hydroxide | (iv) Solvay          |

Choose the correct answer from the options given below :

Options :

70819169081. (a) → (iv), (b) → (iii), (c) → (i), (d) → (ii)

70819169082. (a) → (iv), (b) → (i), (c) → (ii), (d) → (iii)

70819169083. (a) → (i), (b) → (iii), (c) → (iv), (d) → (ii)

70819169084. (a) → (iii), (b) → (ii), (c) → (i), (d) → (iv)

Question Number : 36 Question Id : 70819121309 Question Type : MCQ Option Shuffling : Yes

Is Question Mandatory : No

Correct Marks : 4 Wrong Marks : 1

তালিকা-I ক তালিকা-II ৰ লগত মিলোৱা :

| তালিকা-I                   | তালিকা-II            |
|----------------------------|----------------------|
| (a) ছ'ডিয়াম কাৰ্ব'নেট     | (i) ডিক্স            |
| (b) টাইটেনিয়াম            | (ii) কাষ্টনাৰ-কেলনাৰ |
| (c) ক্ল'ৰিন                | (iii) ভন আৰকেল       |
| (d) ছ'ডিয়াম হাইড্ৰ'ক্সাইড | (iv) ছলভে            |

তলত দিয়া বিকল্পবোৰৰ পৰা শুদ্ধ উত্তৰটো বাছি উলিওৱা :

**Options :**

70819169081. (a) → (iv), (b) → (iii), (c) → (i), (d) → (ii)

70819169082. (a) → (iv), (b) → (i), (c) → (ii), (d) → (iii)

70819169083. (a) → (i), (b) → (iii), (c) → (iv), (d) → (ii)

70819169084. (a) → (iii), (b) → (ii), (c) → (i), (d) → (iv)

**Question Number : 37 Question Id : 70819121310 Question Type : MCQ Option Shuffling : Yes**

**Is Question Mandatory : No**

**Correct Marks : 4 Wrong Marks : 1**

Which pair of oxides is acidic in nature ?

**Options :**

70819169085.  $B_2O_3, SiO_2$

70819169086.  $B_2O_3, CaO$

70819169087.  $N_2O, BaO$

70819169088.  $CaO, SiO_2$

Question Number : 37 Question Id : 70819121310 Question Type : MCQ Option Shuffling : Yes

Is Question Mandatory : No

Correct Marks : 4 Wrong Marks : 1

তলৰ কোনযোৰ অক্সাইড আংশিক প্ৰকৃতিৰ ?

Options :

70819169085.  $B_2O_3, SiO_2$

70819169086.  $B_2O_3, CaO$

70819169087.  $N_2O, BaO$

70819169088.  $CaO, SiO_2$

Question Number : 38 Question Id : 70819121311 Question Type : MCQ Option Shuffling : Yes

Is Question Mandatory : No

Correct Marks : 4 Wrong Marks : 1

Given below are two statements : one is labelled as Assertion A and the other is labelled as Reason R.

Assertion A : In  $TlI_3$ , isomorphous to  $CsI_3$ , the metal is present in +1 oxidation state.

Reason R : Tl metal has fourteen  $f$  electrons in its electronic configuration.

In the light of the above statements, choose the most appropriate answer from the options given below :

Options :

70819169089. Both A and R are correct and R is the correct explanation of A

70819169090. Both A and R are correct but R is NOT the correct explanation of A

70819169091. A is correct but R is not correct

70819169092. A is not correct but R is correct

Question Number : 38 Question Id : 70819121311 Question Type : MCQ Option Shuffling : Yes

Is Question Mandatory : No

Correct Marks : 4 Wrong Marks : 1

তলত দুটাকৈ উক্তি দিয়া আছে : এটাক কথন A হিচাবে চিহ্নিত কৰা হৈছে আৰু আনটো কাৰণ R হিচাবে চিহ্নিত কৰা হৈছে।

কথন A :  $TlI_3$  ত CsI<sub>3</sub> ৰ অনুৰূপ ধাতুটো +1 জাৰণ অৱস্থাত আছে।

কাৰণ R : Tl ধাতুৰ ইলেক্ট্ৰনীয় বিন্যাসত চৈধ্যটা  $f$  ইলেক্ট্ৰন আছে।

ওপৰৰ উক্তি দুটাৰ ভিত্তিত, তলত দিয়া বিকল্পবোৰৰ পৰা উপযুক্ততম উত্তৰটো বাছি উলিওৱা।

Options :

70819169089. A আৰু R ৰ দুয়োটা শুদ্ধ আৰু R হ'ল A ৰ শুদ্ধ ব্যাখ্যা।

70819169090. A আৰু R ৰ দুয়োটা শুদ্ধ কিন্তু R, A ৰ শুদ্ধ ব্যাখ্যা নহয়।

70819169091. A শুদ্ধ কিন্তু R শুদ্ধ নহয়।

70819169092. A শুদ্ধ নহয় কিন্তু R শুদ্ধ।

Question Number : 39 Question Id : 70819121312 Question Type : MCQ Option Shuffling : Yes

Is Question Mandatory : No

Correct Marks : 4 Wrong Marks : 1

Calgon is used for water treatment. Which of the following statement is NOT true about Calgon ?

Options :

70819169093. Calgon contains the 2<sup>nd</sup> most abundant element by weight in the Earth's crust.

70819169094. It is polymeric compound and is water soluble.

70819169095. It is also known as Graham's salt.

70819169096. It doesnot remove  $Ca^{2+}$  ion by precipitation.

Question Number : 39 Question Id : 70819121312 Question Type : MCQ Option Shuffling : Yes  
Is Question Mandatory : No

Correct Marks : 4 Wrong Marks : 1

পানী পৰিশোধনত কেলগন ব্যৱহাৰ কৰা হয়। কেলগনৰ বিষয়ে তলৰ কোনটো উক্তি সত্য নহয় ?

Options :

70819169093. ভৰ হিচাপে পৃথিৱীৰ খোলাত দ্বিতীয় প্ৰাচুৰ্য্যসম্পন্ন মৌলটো কেলগনত থাকে।

70819169094. ই এটা বহুযোগীয় যৌগ আৰু ই পানীত দ্ৰব্য।

70819169095. ইয়াক গ্ৰাহমৰ লবণ হিচাপেও জনা যায়।

70819169096. ই অধঃক্ষেপণৰ জৰিয়তে  $\text{Ca}^{2+}$  আয়ন আঁতৰ নকৰে।

Question Number : 40 Question Id : 70819121313 Question Type : MCQ Option Shuffling : Yes  
Is Question Mandatory : No

Correct Marks : 4 Wrong Marks : 1

Ceric ammonium nitrate and  $\text{CHCl}_3/\text{alc. KOH}$  are used for the identification of functional groups present in \_\_\_\_\_ and \_\_\_\_\_ respectively.

Options :

70819169097. alcohol, amine

70819169098. amine, alcohol

70819169099. alcohol, phenol

70819169100. amine, phenol

Question Number : 40 Question Id : 70819121313 Question Type : MCQ Option Shuffling : Yes

Is Question Mandatory : No

Correct Marks : 4 Wrong Marks : 1

চেৰিক এম'নিয়াম নাইট্ৰেট আৰু  $\text{CHCl}_3/\text{alc. KOH}$  ব্যৱহাৰ কৰা হয় \_\_\_\_\_ আৰু \_\_\_\_\_ ত থকা কাৰ্য্যকৰী মূলকৰ চিনাক্তকৰণৰ বাবে, যথাক্ৰমে।

Options :

70819169097. এলক'হল, এমাইন

70819169098. এমাইন, এলক'হল

70819169099. এলক'হল, ফিনল

70819169100. এমাইন, ফিনল

Question Number : 41 Question Id : 70819121314 Question Type : MCQ Option Shuffling : Yes

Is Question Mandatory : No

Correct Marks : 4 Wrong Marks : 1

In  $\overset{1}{\text{C}}\text{H}_2 = \overset{2}{\text{C}} = \overset{3}{\text{C}}\text{H} - \overset{4}{\text{C}}\text{H}_3$  molecule, the hybridization of carbon 1, 2, 3 and 4 respectively, are :

Options :

70819169101.  $sp^2, sp^2, sp^2, sp^3$

70819169102.  $sp^3, sp, sp^3, sp^3$

70819169103.  $sp^2, sp, sp^2, sp^3$

70819169104.  $sp^2, sp^3, sp^2, sp^3$

Question Number : 41 Question Id : 70819121314 Question Type : MCQ Option Shuffling : Yes

Is Question Mandatory : No

Correct Marks : 4 Wrong Marks : 1

$\overset{1}{\text{C}}\text{H}_2 = \overset{2}{\text{C}} = \overset{3}{\text{C}}\text{H} - \overset{4}{\text{C}}\text{H}_3$  অণুত, কার্বন 1, 2, 3 আৰু 4 ৰ সংকৰণ যথাক্রমে হ'ল :

Options :

70819169101.  $sp^2, sp^2, sp^2, sp^3$

70819169102.  $sp^3, sp, sp^3, sp^3$

70819169103.  $sp^2, sp, sp^2, sp^3$

70819169104.  $sp^2, sp^3, sp^2, sp^3$

Question Number : 42 Question Id : 70819121315 Question Type : MCQ Option Shuffling : Yes

Is Question Mandatory : No

Correct Marks : 4 Wrong Marks : 1

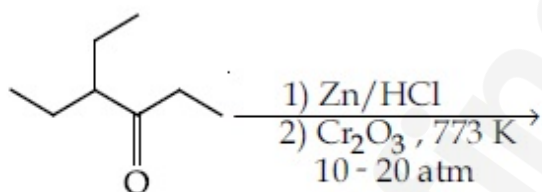

Considering the above reaction, the major product among the following is :

Options :

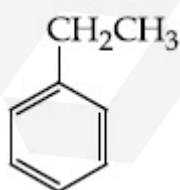

70819169105.

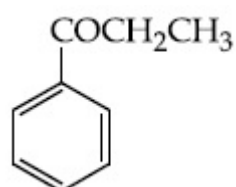

70819169106.

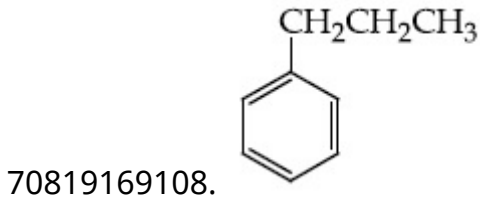
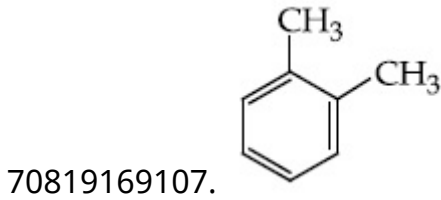

Question Number : 42 Question Id : 70819121315 Question Type : MCQ Option Shuffling : Yes

Is Question Mandatory : No

Correct Marks : 4 Wrong Marks : 1

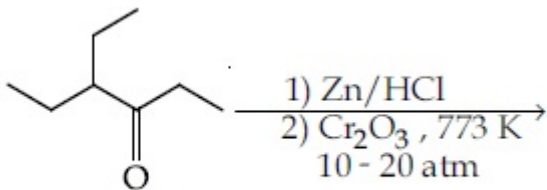

ওপৰোক্ত বিক্ৰিয়াটো লোৱা, তলত দিয়াবোৰৰ ভিতৰত প্ৰধান জাতদ্রব্য :

Options :

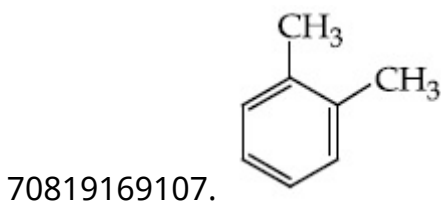
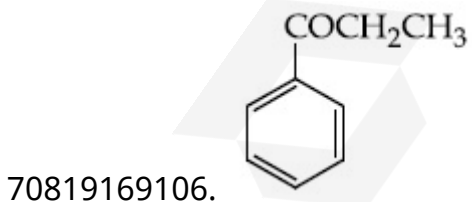
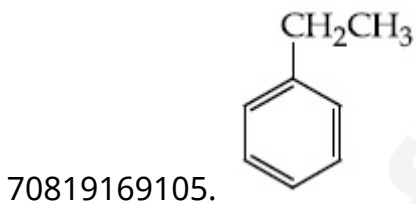

70819169108.

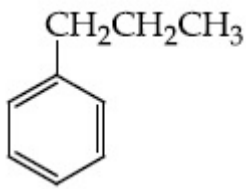

Question Number : 43 Question Id : 70819121316 Question Type : MCQ Option Shuffling : Yes  
Is Question Mandatory : No

Correct Marks : 4 Wrong Marks : 1

Identify A in the given reaction.

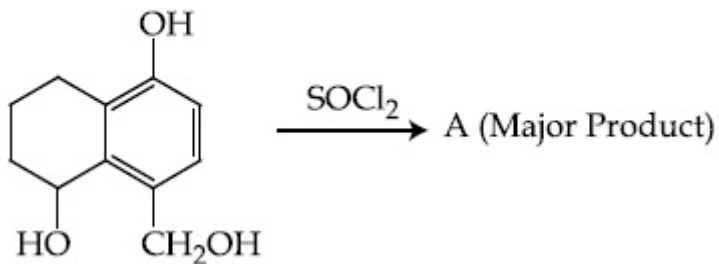

Options :

70819169109.

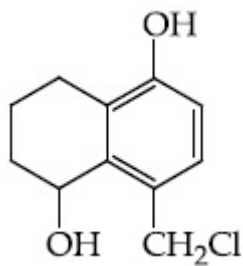

70819169110.

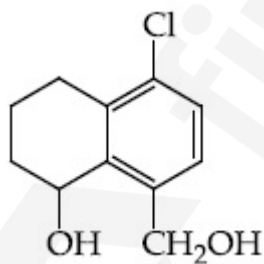

70819169111.

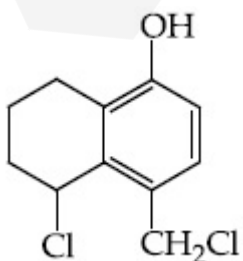

70819169112.

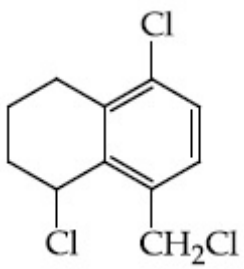

Question Number : 43 Question Id : 70819121316 Question Type : MCQ Option Shuffling : Yes

Is Question Mandatory : No

Correct Marks : 4 Wrong Marks : 1

প্রদত্ত বিক্রিয়াটোত A চিনাক্ত করা :

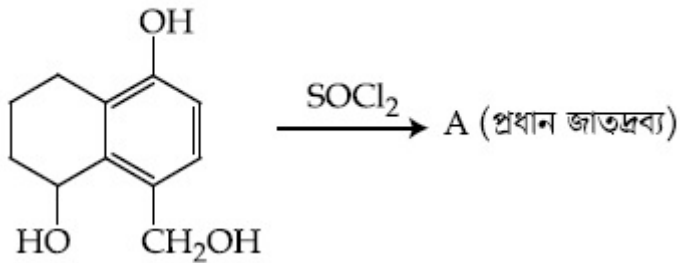

Options :

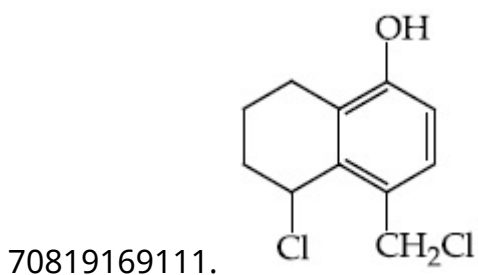
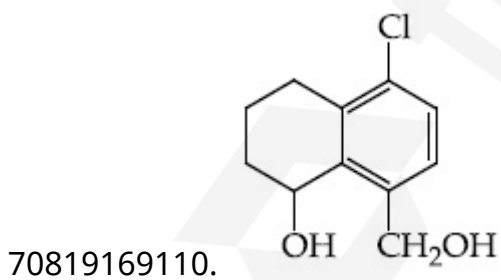
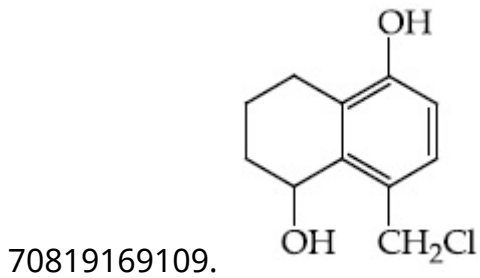

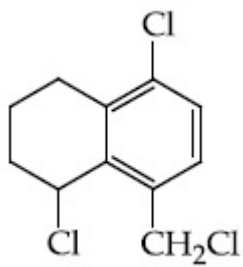

70819169112.

**Question Number : 44 Question Id : 70819121317 Question Type : MCQ Option Shuffling : Yes Is Question Mandatory : No**

**Correct Marks : 4 Wrong Marks : 1**

Identify A in the given chemical reaction.

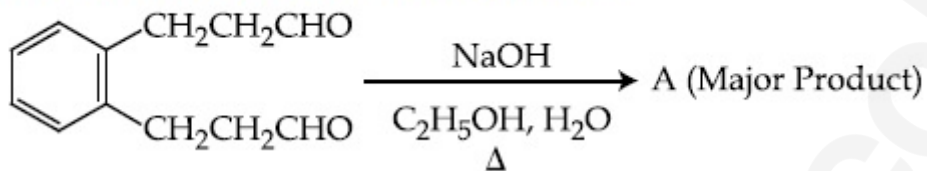

**Options :**

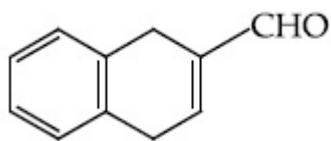

70819169113.

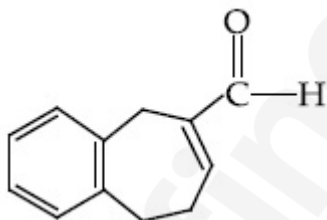

70819169114.

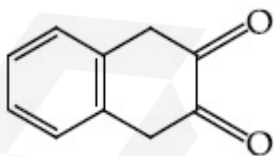

70819169115.

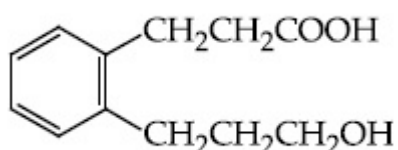

70819169116.

Question Number : 44 Question Id : 70819121317 Question Type : MCQ Option Shuffling : Yes

Is Question Mandatory : No

Correct Marks : 4 Wrong Marks : 1

প্রদত্ত বাসায়নিক বিক্রিয়াত A চিনাক্ত করা :

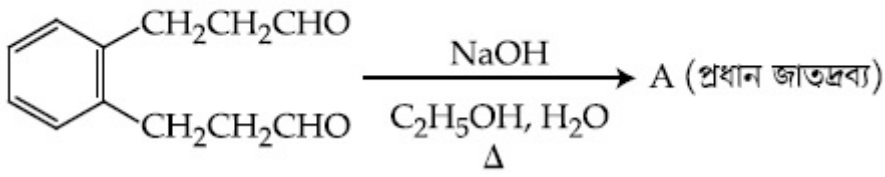

Options :

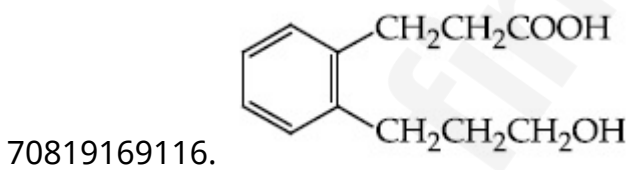
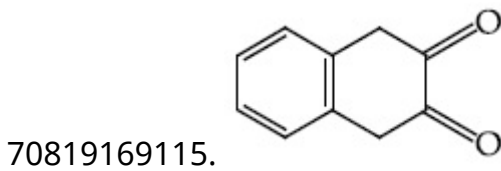
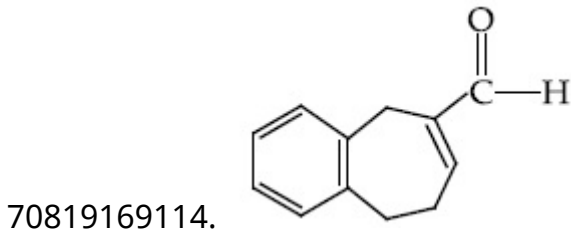
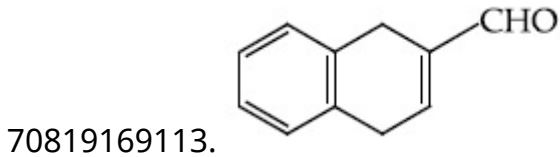

Question Number : 45 Question Id : 70819121318 Question Type : MCQ Option Shuffling : Yes

Is Question Mandatory : No

Correct Marks : 4 Wrong Marks : 1

Identify A in the following chemical reaction.

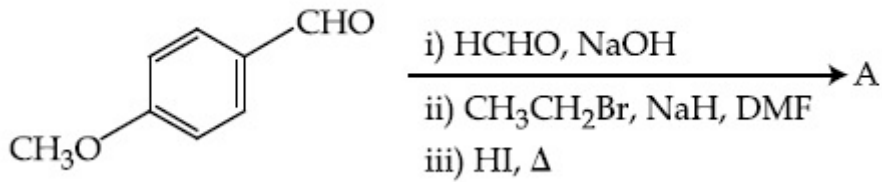

Options :

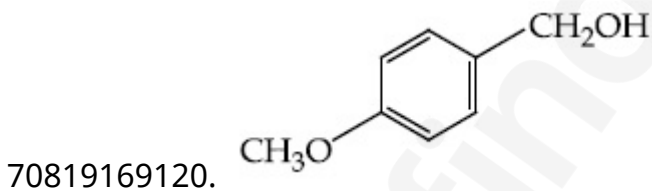
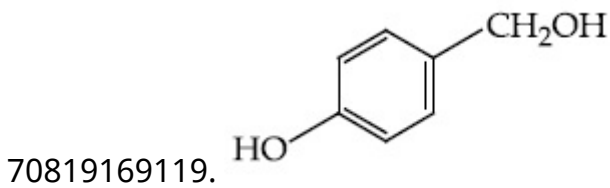
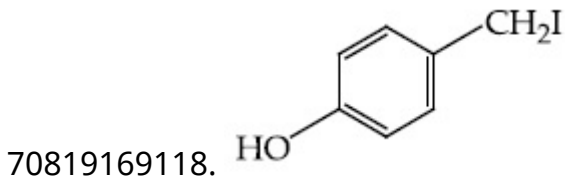
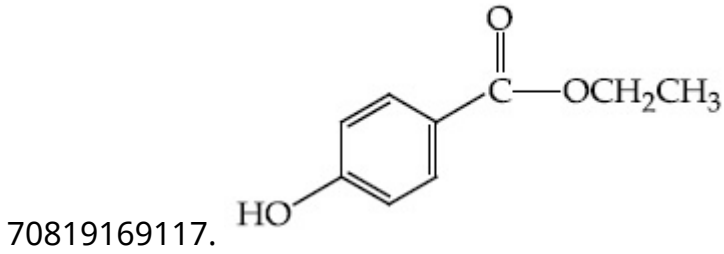

Question Number : 45 Question Id : 70819121318 Question Type : MCQ Option Shuffling : Yes

Is Question Mandatory : No

Correct Marks : 4 Wrong Marks : 1

তলত দিয়া ৰাসায়নিক বিক্ৰিয়াত A চিনাক্ত কৰা :

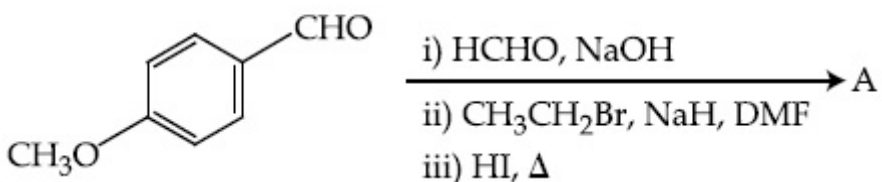

Options :

70819169117.

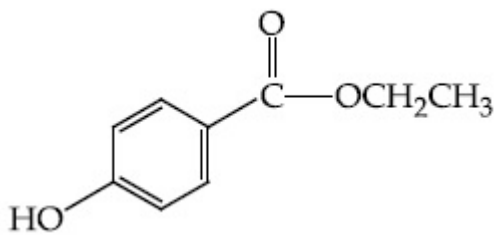

70819169118.

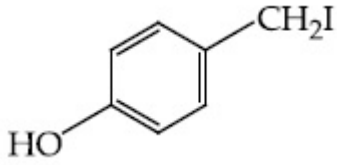

70819169119.

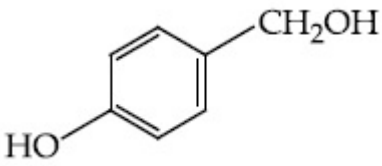

70819169120.

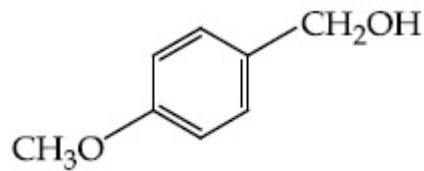

Question Number : 46 Question Id : 70819121319 Question Type : MCQ Option Shuffling : Yes

Is Question Mandatory : No

Correct Marks : 4 Wrong Marks : 1

Match List-I with List-II.

List-I

List-II

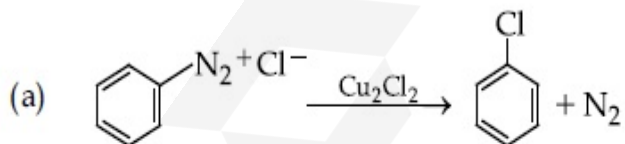

(i) Wurtz reaction

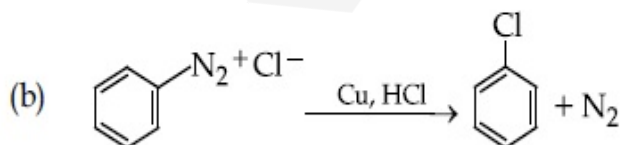

(ii) Sandmeyer reaction

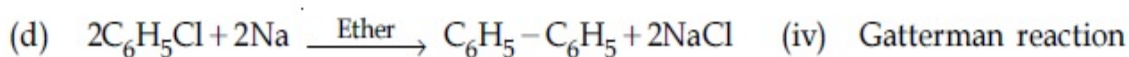
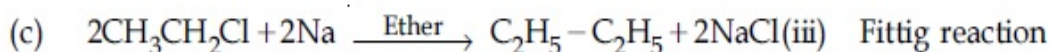

Choose the correct answer from the options given below :

**Options :**

70819169121. (a) → (ii), (b) → (iv), (c) → (i), (d) → (iii)

70819169122. (a) → (ii), (b) → (i), (c) → (iv), (d) → (iii)

70819169123. (a) → (iii), (b) → (i), (c) → (iv), (d) → (ii)

70819169124. (a) → (iii), (b) → (iv), (c) → (i), (d) → (ii)

**Question Number : 46 Question Id : 70819121319 Question Type : MCQ Option Shuffling : Yes**

**Is Question Mandatory : No**

**Correct Marks : 4 Wrong Marks : 1**

তালিকা-I ক তালিকা-II ৰ লগত মিলোৱা :

তালিকা-I

তালিকা-II

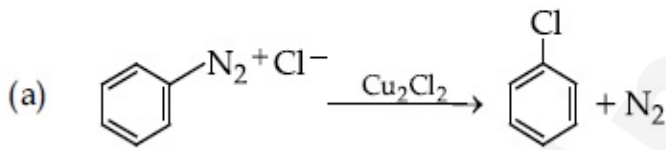

(i) উৰজ বিক্ৰিয়া

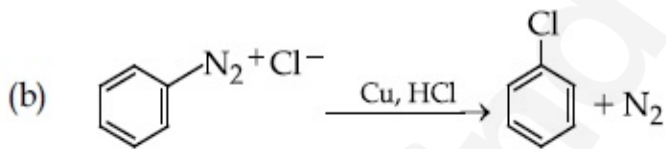

(ii) চেন্দমেয়াৰ বিক্ৰিয়া

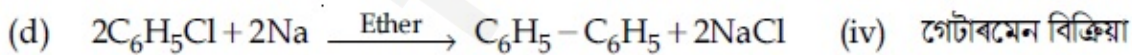

তলত দিয়া বিকল্পবোৰৰ পৰা শুদ্ধ উত্তৰটো বাছি উলিওৱা :

**Options :**

70819169121. (a) → (ii), (b) → (iv), (c) → (i), (d) → (iii)

70819169122. (a) → (ii), (b) → (i), (c) → (iv), (d) → (iii)

70819169123. (a) → (iii), (b) → (i), (c) → (iv), (d) → (ii)

Question Number : 47 Question Id : 70819121320 Question Type : MCQ Option Shuffling : Yes

Is Question Mandatory : No

Correct Marks : 4 Wrong Marks : 1

Seliwanoff test and Xanthoproteic test are used for the identification of \_\_\_\_\_ and \_\_\_\_\_ respectively.

Options :

70819169125. aldoses, ketoses

70819169126. ketoses, aldoses

70819169127. ketoses, proteins

70819169128. proteins, ketoses

Question Number : 47 Question Id : 70819121320 Question Type : MCQ Option Shuffling : Yes

Is Question Mandatory : No

Correct Marks : 4 Wrong Marks : 1

সেইলিওৱানফ পৰীক্ষা আৰু জেছ'প্ৰ'টাইক পৰীক্ষা ক্ৰমে \_\_\_\_\_ আৰু \_\_\_\_\_ ৰ চিনাক্তকৰণৰ বাবে ব্যৱহাৰ কৰা হয়।

Options :

70819169125. এলড'জ, কিট'জ

70819169126. কিট'জ, এলড'জ

70819169127. কিট'জ, প্ৰ'টিন

70819169128. প্ৰ'টিন, কিট'জ

Question Number : 48 Question Id : 70819121321 Question Type : MCQ Option Shuffling : Yes  
Is Question Mandatory : No

Correct Marks : 4 Wrong Marks : 1

Match List-I with List-II.

| List-I      | List-II   |
|-------------|---|
| (a) Sucrose | (i) $\beta$ -D-Galactose and $\beta$ -D-Glucose   |
| (b) Lactose | (ii) $\alpha$ -D-Glucose and $\beta$ -D-Fructose  |
| (c) Maltose | (iii) $\alpha$ -D-Glucose and $\alpha$ -D-Glucose |

Choose the correct answer from the options given below :

Options :

70819169129. (a)  $\rightarrow$  (ii), (b)  $\rightarrow$  (i), (c)  $\rightarrow$  (iii)

70819169130. (a)  $\rightarrow$  (iii), (b)  $\rightarrow$  (ii), (c)  $\rightarrow$  (i)

70819169131. (a)  $\rightarrow$  (i), (b)  $\rightarrow$  (iii), (c)  $\rightarrow$  (ii)

70819169132. (a)  $\rightarrow$  (iii), (b)  $\rightarrow$  (i), (c)  $\rightarrow$  (ii)

Question Number : 48 Question Id : 70819121321 Question Type : MCQ Option Shuffling : Yes  
Is Question Mandatory : No

Correct Marks : 4 Wrong Marks : 1

তালিকা-I ক তালিকা-II ৰ লগত মিলোৱা :

| তালিকা-I    | তালিকা-II   |
|-------------|---|
| (a) চুক্র'জ | (i) $\beta$ -D-গেলেক্ট'জ আৰু $\beta$ -D-গ্লুক'জ   |
| (b) লেক্ট'জ | (ii) $\alpha$ -D-গ্লুক'জ আৰু $\beta$ -D-ফ্রুক্ট'জ |
| (c) মেল্ট'জ | (iii) $\alpha$ -D-গ্লুক'জ আৰু $\alpha$ -D-গ্লুক'জ |

তলত দিয়া বিকল্পবোৰৰ পৰা শুদ্ধ উত্তৰটো বাছি উলিওৱা :

Options :

70819169129. (a)  $\rightarrow$  (ii), (b)  $\rightarrow$  (i), (c)  $\rightarrow$  (iii)

70819169130. (a) → (iii), (b) → (ii), (c) → (i)

70819169131. (a) → (i), (b) → (iii), (c) → (ii)

70819169132. (a) → (iii), (b) → (i), (c) → (ii)

**Question Number : 49 Question Id : 70819121322 Question Type : MCQ Option Shuffling : Yes**

**Is Question Mandatory : No**

**Correct Marks : 4 Wrong Marks : 1**

2,4-DNP test can be used to identify :

**Options :**

70819169133. halogens

70819169134. aldehyde

70819169135. amine

70819169136. ether

**Question Number : 49 Question Id : 70819121322 Question Type : MCQ Option Shuffling : Yes**

**Is Question Mandatory : No**

**Correct Marks : 4 Wrong Marks : 1**

2,4-DNP পৰীক্ষা ব্যৱহাৰ কৰা হয় চিনাক্তকৰণৰ বাবে :

**Options :**

70819169133. হেল'জেন ব

70819169134. এলডিহাইড ব

70819169135. এমাইন ব

70819169136. ইথাৰ ৰ

Question Number : 50 Question Id : 70819121323 Question Type : MCQ Option Shuffling : Yes

Is Question Mandatory : No

Correct Marks : 4 Wrong Marks : 1

- A. Phenyl methanamine
- B. N,N-Dimethylaniline
- C. N-Methyl aniline
- D. Benzenamine

Choose the correct order of basic nature of the above amines.

Options :

70819169137.  $A > B > C > D$

70819169138.  $D > C > B > A$

70819169139.  $A > C > B > D$

70819169140.  $D > B > C > A$

Question Number : 50 Question Id : 70819121323 Question Type : MCQ Option Shuffling : Yes

Is Question Mandatory : No

Correct Marks : 4 Wrong Marks : 1

- A. ফিনাইল মিথেনেমাইন
- B. N,N-ডাইমিথাইল এনিলিন
- C. N-মিথাইলেনিলিন
- D. বেনজিনেমাইন

ওপৰৰ এমাইনসমূহৰ ক্ষাৰকীয় প্ৰকৃতিৰ শুদ্ধ ক্ৰমটো বাছি উলিওৱা।

Options :

70819169137.  $A > B > C > D$

70819169138.  $D > C > B > A$

70819169139.  $A > C > B > D$

70819169140.  $D > B > C > A$

## Chemistry Section B

|                                       |            |
|---------------------------------------|------------|
| Section Id :                          | 708191961  |
| Section Number :                      | 4          |
| Section type :                        | Online     |
| Mandatory or Optional :               | Mandatory  |
| Number of Questions :                 | 10         |
| Number of Questions to be attempted : | 5          |
| Section Marks :                       | 20         |
| Mark As Answered Required? :          | Yes        |
| Sub-Section Number :                  | 1          |
| Sub-Section Id :                      | 7081911241 |
| Question Shuffling Allowed :          | Yes        |

Question Number : 51 Question Id : 70819121324 Question Type : SA

Correct Marks : 4 Wrong Marks : 0

The  $\text{NaNO}_3$  weighed out to make 50 mL of an aqueous solution containing 70.0 mg  $\text{Na}^+$  per mL is \_\_\_\_\_ g. (Rounded off to the nearest integer)

[Given : Atomic weight in  $\text{g mol}^{-1}$  - Na : 23 ; N : 14 ; O : 16]

Response Type : Numeric

Evaluation Required For SA : Yes

Show Word Count : Yes

**Answers Type :** Range

**Text Areas :** PlainText

**Possible Answers :**

5 to 5.001

**Question Number : 51 Question Id : 70819121324 Question Type : SA**

**Correct Marks : 4 Wrong Marks : 0**

প্রতি mL ত 70.0 mg  $\text{Na}^+$  থকা এটা 50 mL দ্ৰৱ বনাবলৈ প্ৰয়োজন হোৱা  $\text{NaNO}_3$  হ'ল \_\_\_\_\_ g।  
(নিকটতম অখণ্ড সংখ্যা)

[দিয়া হ'ল :  $\text{g mol}^{-1}$  ত পাৰমাণবিক ভৰ - Na : 23 ; N : 14 ; O : 16]

**Response Type :** Numeric

**Evaluation Required For SA :** Yes

**Show Word Count :** Yes

**Answers Type :** Range

**Text Areas :** PlainText

**Possible Answers :**

5 to 5.001

**Question Number : 52 Question Id : 70819121325 Question Type : SA**

**Correct Marks : 4 Wrong Marks : 0**

The number of octahedral voids per lattice site in a lattice is \_\_\_\_\_. (Rounded off to the nearest integer)

**Response Type :** Numeric

**Evaluation Required For SA :** Yes

**Show Word Count :** Yes

**Answers Type :** Range

**Text Areas :** PlainText

**Possible Answers :**

5 to 5.001

Question Number : 52 Question Id : 70819121325 Question Type : SA

Correct Marks : 4 Wrong Marks : 0

এটা লেটিছৰ প্ৰতি লেটিছ চাইটত (site) অষ্টফলকীয় শূন্যস্থানৰ (voids) সংখ্যা হ'ল \_\_\_\_\_। (অখণ্ড সংখ্যাত)

Response Type : Numeric

Evaluation Required For SA : Yes

Show Word Count : Yes

Answers Type : Range

Text Areas : PlainText

Possible Answers :

5 to 5.001

Question Number : 53 Question Id : 70819121326 Question Type : SA

Correct Marks : 4 Wrong Marks : 0

A ball weighing 10 g is moving with a velocity of  $90 \text{ ms}^{-1}$ . If the uncertainty in its velocity is 5%, then the uncertainty in its position is \_\_\_\_\_  $\times 10^{-33} \text{ m}$ . (Rounded off to the nearest integer)

[Given :  $h = 6.63 \times 10^{-34} \text{ Js}$ ]

Response Type : Numeric

Evaluation Required For SA : Yes

Show Word Count : Yes

Answers Type : Range

Text Areas : PlainText

Possible Answers :

5 to 5.001

Question Number : 53 Question Id : 70819121326 Question Type : SA

Correct Marks : 4 Wrong Marks : 0

10 g ভৰৰ বল এটা  $90 \text{ ms}^{-1}$  বেগত গতি কৰি আছে। যদিহে ইয়াৰ গতিবেগৰ অনিশ্চয়তা 5%, তেনেহ'লে ইয়াৰ অৱস্থান অনিশ্চয়তা হ'ল \_\_\_\_\_  $\times 10^{-33} \text{ m}$ । (অখণ্ড সংখ্যাত)

[দিয়া হ'ল :  $h = 6.63 \times 10^{-34} \text{ Js}$ ]

Response Type : Numeric

**Evaluation Required For SA :** Yes

**Show Word Count :** Yes

**Answers Type :** Range

**Text Areas :** PlainText

**Possible Answers :**

5 to 5.001

**Question Number :** 54 **Question Id :** 70819121327 **Question Type :** SA

**Correct Marks :** 4 **Wrong Marks :** 0

The average S–F bond energy in  $\text{kJ mol}^{-1}$  of  $\text{SF}_6$  is \_\_\_\_\_. (Rounded off to the nearest integer)

[Given : The values of standard enthalpy of formation of  $\text{SF}_6(\text{g})$ ,  $\text{S}(\text{g})$  and  $\text{F}(\text{g})$  are - 1100, 275 and  $80 \text{ kJ mol}^{-1}$  respectively.]

**Response Type :** Numeric

**Evaluation Required For SA :** Yes

**Show Word Count :** Yes

**Answers Type :** Range

**Text Areas :** PlainText

**Possible Answers :**

5 to 5.001

**Question Number :** 54 **Question Id :** 70819121327 **Question Type :** SA

**Correct Marks :** 4 **Wrong Marks :** 0

$\text{SF}_6$  ত  $\text{kJ mol}^{-1}$  এককত গড় S–F বান্ধনিশক্তি হ'ল \_\_\_\_\_. (নিকটতম অখণ্ড সংখ্যাত উত্তৰ)

[দিয়া হ'ল :  $\text{SF}_6(\text{g})$ ,  $\text{S}(\text{g})$  আৰু  $\text{F}(\text{g})$  ৰ প্ৰমাণ সংগঠন এন্থালপি যথাক্ৰমে - 1100, 275 আৰু  $80 \text{ kJ mol}^{-1}$  ]

**Response Type :** Numeric

**Evaluation Required For SA :** Yes

**Show Word Count :** Yes

**Answers Type :** Range

**Text Areas :** PlainText

**Possible Answers :**

**Question Number : 55 Question Id : 70819121328 Question Type : SA**

**Correct Marks : 4 Wrong Marks : 0**

When 12.2 g of benzoic acid is dissolved in 100 g of water, the freezing point of solution was found to be  $-0.93^{\circ}\text{C}$  ( $K_f(\text{H}_2\text{O}) = 1.86 \text{ K kg mol}^{-1}$ ). The number (n) of benzoic acid molecules associated (assuming 100% association) is \_\_\_\_\_.

**Response Type : Numeric**

**Evaluation Required For SA : Yes**

**Show Word Count : Yes**

**Answers Type : Range**

**Text Areas : PlainText**

**Possible Answers :**

5 to 5.001

**Question Number : 55 Question Id : 70819121328 Question Type : SA**

**Correct Marks : 4 Wrong Marks : 0**

যেতিয়া বেনয'য়িক এছিডৰ 12.2 g, 100 g পানীত দ্ৰৱীভূত কৰা হ'ল, দ্ৰৱটোৰ হিমাংক  $-0.93^{\circ}\text{C}$  পোৱা গ'ল ( $K_f(\text{H}_2\text{O}) = 1.86 \text{ K kg mol}^{-1}$ )। সংযোজিত হোৱা বেনয'ইক এছিড অণুৰ (100% সংযোজন ধৰি লৈ) সংখ্যা হ'ল \_\_\_\_\_।

**Response Type : Numeric**

**Evaluation Required For SA : Yes**

**Show Word Count : Yes**

**Answers Type : Range**

**Text Areas : PlainText**

**Possible Answers :**

5 to 5.001

**Question Number : 56 Question Id : 70819121329 Question Type : SA**

**Correct Marks : 4 Wrong Marks : 0**

The pH of ammonium phosphate solution, if  $pK_a$  of phosphoric acid and  $pK_b$  of ammonium hydroxide are 5.23 and 4.75 respectively, is \_\_\_\_\_.

**Response Type :** Numeric

**Evaluation Required For SA :** Yes

**Show Word Count :** Yes

**Answers Type :** Range

**Text Areas :** PlainText

**Possible Answers :**

5 to 5.001

**Question Number :** 56 **Question Id :** 70819121329 **Question Type :** SA

**Correct Marks :** 4 **Wrong Marks :** 0

যদিহে ফছফ'ৰিক এছিডৰ  $pK_a$  আৰু এম'নিয়াম হাইড্ৰ'ক্সাইডৰ  $pK_b$  যথাক্ৰমে 5.23 আৰু 4.75, এম'নিয়াম ফছফেট দ্ৰৱৰ pH হ'ব \_\_\_\_\_।

**Response Type :** Numeric

**Evaluation Required For SA :** Yes

**Show Word Count :** Yes

**Answers Type :** Range

**Text Areas :** PlainText

**Possible Answers :**

5 to 5.001

**Question Number :** 57 **Question Id :** 70819121330 **Question Type :** SA

**Correct Marks :** 4 **Wrong Marks :** 0

Emf of the following cell at 298 K in V is  $x \times 10^{-2}$ .

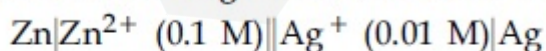

The value of  $x$  is \_\_\_\_\_. (Rounded off to the nearest integer)

[Given :  $E^\theta_{\text{Zn}^{2+}/\text{Zn}} = -0.76 \text{ V}$  ;  $E^\theta_{\text{Ag}^+/\text{Ag}} = +0.80 \text{ V}$  ;  $\frac{2.303RT}{F} = 0.059$ ]

**Response Type :** Numeric

**Evaluation Required For SA :** Yes

Show Word Count : Yes

Answers Type : Range

Text Areas : PlainText

Possible Answers :

5 to 5.001

Question Number : 57 Question Id : 70819121330 Question Type : SA

Correct Marks : 4 Wrong Marks : 0

298 K উষ্ণতাত V এককত তলত দিয়া কোষটোৰ বিদ্যুৎচালক বল (emf) হ'ল  $x \times 10^{-2}$ ।

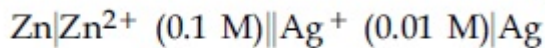

$x$  ৰ মান হ'ল \_\_\_\_\_। (নিকটতম অখণ্ড সংখ্যাত)

[দিয়া হ'ল :  $E_{\text{Zn}^{2+}/\text{Zn}}^{\theta} = -0.76 \text{ V}$  ;  $E_{\text{Ag}^+/\text{Ag}}^{\theta} = +0.80 \text{ V}$  ;  $\frac{2.303RT}{F} = 0.059$ ]

Response Type : Numeric

Evaluation Required For SA : Yes

Show Word Count : Yes

Answers Type : Range

Text Areas : PlainText

Possible Answers :

5 to 5.001

Question Number : 58 Question Id : 70819121331 Question Type : SA

Correct Marks : 4 Wrong Marks : 0

If the activation energy of a reaction is  $80.9 \text{ kJ mol}^{-1}$ , the fraction of molecules at 700 K, having enough energy to react to form products is  $e^{-x}$ . The value of  $x$  is \_\_\_\_\_.  
(Rounded off to the nearest integer)

[Use  $R = 8.31 \text{ J K}^{-1} \text{ mol}^{-1}$ ]

Response Type : Numeric

Evaluation Required For SA : Yes

Show Word Count : Yes

Answers Type : Range

Text Areas : PlainText

Possible Answers :

5 to 5.001

Question Number : 58 Question Id : 70819121331 Question Type : SA

Correct Marks : 4 Wrong Marks : 0

যদি কোনো বিক্রিয়াৰ সক্ৰিয় শক্তি  $80.9 \text{ kJ mol}^{-1}$  হয়,  $700 \text{ K}$  উষ্ণতাত জাতদ্রব্য গঠন কৰিবলৈ যথেষ্ট শক্তি থকা অণুৰ অংশ হ'ল  $e^{-x}$ ।  $x$  ৰ মান হ'ল \_\_\_\_\_। (নিকটতম অখণ্ড সংখ্যাত)

[ব্যৱহাৰ কৰা :  $R = 8.31 \text{ J K}^{-1} \text{ mol}^{-1}$ ]

Response Type : Numeric

Evaluation Required For SA : Yes

Show Word Count : Yes

Answers Type : Range

Text Areas : PlainText

Possible Answers :

5 to 5.001

Question Number : 59 Question Id : 70819121332 Question Type : SA

Correct Marks : 4 Wrong Marks : 0

In mildly alkaline medium, thiosulphate ion is oxidized by  $\text{MnO}_4^-$  to "A". The oxidation state of sulphur in "A" is \_\_\_\_\_.

Response Type : Numeric

Evaluation Required For SA : Yes

Show Word Count : Yes

Answers Type : Range

Text Areas : PlainText

Possible Answers :

5 to 5.001

Question Number : 59 Question Id : 70819121332 Question Type : SA

Correct Marks : 4 Wrong Marks : 0

মুদ্রণ ক্রমিকীয় মাধ্যমত,  $\text{MnO}_4^-$  আয়নে থায়'ছালফেট আয়নক "A" লৈ জাৰিত কৰে। "A" ত ছালফেট আয়নক "B" লৈ জাৰিত কৰে।  
হ'ল \_\_\_\_\_।

**Response Type :** Numeric

**Evaluation Required For SA :** Yes

**Show Word Count :** Yes

**Answers Type :** Range

**Text Areas :** PlainText

**Possible Answers :**

5 to 5.001

**Question Number :** 60 **Question Id :** 70819121333 **Question Type :** SA

**Correct Marks :** 4 **Wrong Marks :** 0

The number of stereoisomers possible for  $[\text{Co}(\text{ox})_2(\text{Br})(\text{NH}_3)]^{2-}$  is \_\_\_\_\_.  
[ox = oxalate]

**Response Type :** Numeric

**Evaluation Required For SA :** Yes

**Show Word Count :** Yes

**Answers Type :** Range

**Text Areas :** PlainText

**Possible Answers :**

5 to 5.001

**Question Number :** 60 **Question Id :** 70819121333 **Question Type :** SA

**Correct Marks :** 4 **Wrong Marks :** 0

$[\text{Co}(\text{ox})_2(\text{Br})(\text{NH}_3)]^{2-}$  ৰ বাবে সম্ভৱপৰ ষ্টেৰিঅ'সমযোগীৰ সংখ্যা হ'ল \_\_\_\_\_।  
[ox = অক্সালেট]

**Response Type :** Numeric

**Evaluation Required For SA :** Yes

**Show Word Count :** Yes

**Answers Type :** Range

**Text Areas :** PlainText

Possible Answers :

5 to 5.001

## Mathematics Section A

|                                       |            |
|---------------------------------------|------------|
| Section Id :                          | 708191962  |
| Section Number :                      | 5          |
| Section type :                        | Online     |
| Mandatory or Optional :               | Mandatory  |
| Number of Questions :                 | 20         |
| Number of Questions to be attempted : | 20         |
| Section Marks :                       | 80         |
| Mark As Answered Required? :          | Yes        |
| Sub-Section Number :                  | 1          |
| Sub-Section Id :                      | 7081911242 |
| Question Shuffling Allowed :          | Yes        |

Question Number : 61 Question Id : 70819121334 Question Type : MCQ Option Shuffling : Yes

Is Question Mandatory : No

Correct Marks : 4 Wrong Marks : 1

If the mirror image of the point  $(1, 3, 5)$  with respect to the plane  $4x - 5y + 2z = 8$  is  $(\alpha, \beta, \gamma)$ , then  $5(\alpha + \beta + \gamma)$  equals :

Options :

70819169151. 39

70819169152. 41

70819169153. 43

70819169154. 47

Question Number : 61 Question Id : 70819121334 Question Type : MCQ Option Shuffling : Yes  
Is Question Mandatory : No

Correct Marks : 4 Wrong Marks : 1

যদি  $4x - 5y + 2z = 8$  সমতলখনৰ সাপেক্ষে  $(1, 3, 5)$  বিন্দুটোৰ দাপোণ প্ৰতিবিন্দু  $(\alpha, \beta, \gamma)$  হয় তেন্তে,  $5(\alpha + \beta + \gamma)$  হ'ব :

Options :

70819169151. 39

70819169152. 41

70819169153. 43

70819169154. 47

Question Number : 62 Question Id : 70819121335 Question Type : MCQ Option Shuffling : Yes  
Is Question Mandatory : No

Correct Marks : 4 Wrong Marks : 1

Let  $A = \{1, 2, 3, \dots, 10\}$  and  $f: A \rightarrow A$  be defined as

$$f(k) = \begin{cases} k + 1 & \text{if } k \text{ is odd} \\ k & \text{if } k \text{ is even} \end{cases}$$

Then the number of possible functions  $g: A \rightarrow A$  such that  $g \circ f = f$  is :

Options :

70819169155.  $5!$

70819169156.  ${}^{10}C_5$

70819169157.  $5^5$

Question Number : 62 Question Id : 70819121335 Question Type : MCQ Option Shuffling : Yes

Is Question Mandatory : No

Correct Marks : 4 Wrong Marks : 1

ধৰা হ'ল  $A = \{1, 2, 3, \dots, 10\}$  এটা সংহতি আৰু  $f: A \rightarrow A$  এটা ফলন যাতে

$$f(k) = \begin{cases} k + 1 & \text{যদি } k \text{ অযুগ্ম} \\ k & \text{যদি } k \text{ যুগ্ম} \end{cases}$$

তেন্তে  $g \circ f = f$  হোৱাকৈ  $g: A \rightarrow A$  হ'ব পৰা সম্ভাৱ্য ফলনৰ সংখ্যা হ'ব :

Options :

70819169155.  $5!$

70819169156.  ${}^{10}C_5$

70819169157.  $5^5$

70819169158.  $10^5$

Question Number : 63 Question Id : 70819121336 Question Type : MCQ Option Shuffling : Yes

Is Question Mandatory : No

Correct Marks : 4 Wrong Marks : 1

Let  $A_1$  be the area of the region bounded by the curves  $y = \sin x$ ,  $y = \cos x$  and  $y$ -axis in the first quadrant. Also, let  $A_2$  be the area of the region bounded by the curves  $y = \sin x$ ,  $y = \cos x$ ,

$x$ -axis and  $x = \frac{\pi}{2}$  in the first quadrant. Then,

Options :

70819169159.  $A_1 : A_2 = 1 : 2$  and  $A_1 + A_2 = 1$

70819169160.  $A_1 : A_2 = 1 : \sqrt{2}$  and  $A_1 + A_2 = 1$

70819169161.  $A_1 = A_2$  and  $A_1 + A_2 = \sqrt{2}$

70819169162.  $2A_1 = A_2$  and  $A_1 + A_2 = 1 + \sqrt{2}$

**Question Number : 63 Question Id : 70819121336 Question Type : MCQ Option Shuffling : Yes**

**Is Question Mandatory : No**

**Correct Marks : 4 Wrong Marks : 1**

ধৰা হ'ল,  $y = \sin x$ ,  $y = \cos x$  আৰু  $y$ -অক্ষৰ দ্বাৰা ১ম চোকত আবদ্ধ ক্ষেত্ৰৰ ক্ষেত্ৰফল  $A_1$  আৰু  $y = \sin x$ ,  $y = \cos x$ ,  $x$ -অক্ষ আৰু  $x = \frac{\pi}{2}$  ৰ দ্বাৰা ১ম চোকত আবদ্ধ ক্ষেত্ৰৰ ক্ষেত্ৰফল  $A_2$  হয়, তেন্তে :

**Options :**

70819169159.  $A_1 : A_2 = 1 : 2$  আৰু  $A_1 + A_2 = 1$

70819169160.  $A_1 : A_2 = 1 : \sqrt{2}$  আৰু  $A_1 + A_2 = 1$

70819169161.  $A_1 = A_2$  আৰু  $A_1 + A_2 = \sqrt{2}$

70819169162.  $2A_1 = A_2$  আৰু  $A_1 + A_2 = 1 + \sqrt{2}$

**Question Number : 64 Question Id : 70819121337 Question Type : MCQ Option Shuffling : Yes**

**Is Question Mandatory : No**

**Correct Marks : 4 Wrong Marks : 1**

If  $0 < a, b < 1$ , and  $\tan^{-1} a + \tan^{-1} b = \frac{\pi}{4}$ , then the value of

$$(a + b) - \left( \frac{a^2 + b^2}{2} \right) + \left( \frac{a^3 + b^3}{3} \right) - \left( \frac{a^4 + b^4}{4} \right) + \dots \text{ is:}$$

**Options :**

70819169163.  $e$

70819169164.  $e^2 - 1$

70819169165.  $\log_e 2$

70819169166.  $\log_e \left( \frac{e}{2} \right)$

Question Number : 64 Question Id : 70819121337 Question Type : MCQ Option Shuffling : Yes

Is Question Mandatory : No

Correct Marks : 4 Wrong Marks : 1

যদি  $0 < a, b < 1$  আৰু  $\tan^{-1} a + \tan^{-1} b = \frac{\pi}{4}$  তেন্তে,

$(a + b) - \left( \frac{a^2 + b^2}{2} \right) + \left( \frac{a^3 + b^3}{3} \right) - \left( \frac{a^4 + b^4}{4} \right) + \dots$  ৰ মান হ'ব :

Options :

70819169163.  $e$

70819169164.  $e^2 - 1$

70819169165.  $\log_e 2$

70819169166.  $\log_e \left( \frac{e}{2} \right)$

Question Number : 65 Question Id : 70819121338 Question Type : MCQ Option Shuffling : Yes

Is Question Mandatory : No

Correct Marks : 4 Wrong Marks : 1

Let slope of the tangent line to a curve at any point  $P(x, y)$  be given by  $\frac{xy^2 + y}{x}$ . If the curve intersects the line  $x + 2y = 4$  at  $x = -2$ , then the value of  $y$ , for which the point  $(3, y)$  lies on the curve, is :

Options :

70819169167.  $-\frac{4}{3}$

70819169168.  $-\frac{18}{19}$

70819169169.  $\frac{18}{35}$

70819169170.  $-\frac{18}{11}$

Question Number : 65 Question Id : 70819121338 Question Type : MCQ Option Shuffling : Yes

Is Question Mandatory : No

Correct Marks : 4 Wrong Marks : 1

ধৰা হ'ল বক্ৰ এটাৰ যিকোনো বিন্দু  $P(x, y)$  ত টা স্পৰ্শকৰ প্ৰৱণতা  $\frac{xy^2 + y}{x}$ । যদি বক্ৰটোৱে  $x + 2y = 4$  ৰেখাটোক  $x = -2$  বিন্দুত ছেদ কৰে, তেন্তে,  $(3, y)$  বিন্দুটো বক্ৰটোৰ ওপৰত থাকাকৈ  $y$  ৰ মান হ'ব :

Options :

70819169167.  $-\frac{4}{3}$

70819169168.  $-\frac{18}{19}$

70819169169.  $\frac{18}{35}$

70819169170.  $-\frac{18}{11}$

**Question Number : 66 Question Id : 70819121339 Question Type : MCQ Option Shuffling : Yes  
Is Question Mandatory : No**

**Correct Marks : 4 Wrong Marks : 1**

The sum of the series  $\sum_{n=1}^{\infty} \frac{n^2 + 6n + 10}{(2n + 1)!}$  is equal to :

**Options :**

70819169171.  $\frac{41}{8}e + \frac{19}{8}e^{-1} - 10$

70819169172.  $\frac{41}{8}e + \frac{19}{8}e^{-1} + 10$

70819169173.  $-\frac{41}{8}e + \frac{19}{8}e^{-1} - 10$

70819169174.  $\frac{41}{8}e - \frac{19}{8}e^{-1} - 10$

**Question Number : 66 Question Id : 70819121339 Question Type : MCQ Option Shuffling : Yes  
Is Question Mandatory : No**

**Correct Marks : 4 Wrong Marks : 1**

$\sum_{n=1}^{\infty} \frac{n^2 + 6n + 10}{(2n + 1)!}$  শ্রেণীটোৰ যোগফল হ'ব :

**Options :**

70819169171.  $\frac{41}{8}e + \frac{19}{8}e^{-1} - 10$

70819169172.  $\frac{41}{8}e + \frac{19}{8}e^{-1} + 10$

70819169173.  $-\frac{41}{8}e + \frac{19}{8}e^{-1} - 10$

70819169174.  $\frac{41}{8}e - \frac{19}{8}e^{-1} - 10$

Question Number : 67 Question Id : 70819121340 Question Type : MCQ Option Shuffling : Yes

Is Question Mandatory : No

Correct Marks : 4 Wrong Marks : 1

Let  $f(x) = \int_0^x e^t f(t) dt + e^x$  be a differentiable function for all  $x \in \mathbb{R}$ . Then  $f(x)$  equals :

Options :

70819169175.  $2e^{(e^x-1)} - 1$

70819169176.  $e^{(e^x-1)}$

70819169177.  $e^{e^x} - 1$

70819169178.  $2e^{e^x} - 1$

Question Number : 67 Question Id : 70819121340 Question Type : MCQ Option Shuffling : Yes

Is Question Mandatory : No

Correct Marks : 4 Wrong Marks : 1

ধৰা হ'ল,  $f(x) = \int_0^x e^t f(t) dt + e^x$  ফলনটো সকলোবোৰ  $x \in \mathbb{R}$  ৰ বাবে অৱকলনীয়। তেন্তে,  $f(x)$  সমান হ'ব :

**Options :**

70819169175.  $2e^{(e^x-1)} - 1$

70819169176.  $e^{(e^x-1)}$

70819169177.  $e^{e^x} - 1$

70819169178.  $2e^{e^x} - 1$

**Question Number : 68 Question Id : 70819121341 Question Type : MCQ Option Shuffling : Yes**

**Is Question Mandatory : No**

**Correct Marks : 4 Wrong Marks : 1**

Let  $f(x)$  be a differentiable function at  $x = a$  with  $f'(a) = 2$  and  $f(a) = 4$ . Then  $\lim_{x \rightarrow a} \frac{xf(a) - af(x)}{x - a}$  equals :

**Options :**

70819169179.  $2a - 4$

70819169180.  $4 - 2a$

70819169181.  $2a + 4$

70819169182.  $a + 4$

**Question Number : 68 Question Id : 70819121341 Question Type : MCQ Option Shuffling : Yes**

Is Question Mandatory : No

Correct Marks : 4 Wrong Marks : 1

ধৰা হ'ল  $x=a$  বিন্দুত  $f(x)$  ফলনটো অৱকলনীয়, য'ত  $f'(a)=2$  আৰু  $f(a)=4$ । তেন্তে,  $\lim_{x \rightarrow a} \frac{xf(a) - af(x)}{x - a}$

সমান হ'ব :

Options :

70819169179.  $2a - 4$

70819169180.  $4 - 2a$

70819169181.  $2a + 4$

70819169182.  $a + 4$

Question Number : 69 Question Id : 70819121342 Question Type : MCQ Option Shuffling : Yes

Is Question Mandatory : No

Correct Marks : 4 Wrong Marks : 1

Let  $f(x) = \sin^{-1} x$  and  $g(x) = \frac{x^2 - x - 2}{2x^2 - x - 6}$ . If  $g(2) = \lim_{x \rightarrow 2} g(x)$ , then the domain of the function  $f \circ g$  is :

Options :

70819169183.  $(-\infty, -2] \cup \left[-\frac{3}{2}, \infty\right)$

70819169184.  $(-\infty, -2] \cup \left[-\frac{4}{3}, \infty\right)$

70819169185.  $(-\infty, -1] \cup [2, \infty)$

70819169186.  $(-\infty, -2] \cup [-1, \infty)$

Question Number : 69 Question Id : 70819121342 Question Type : MCQ Option Shuffling : Yes  
Is Question Mandatory : No

Correct Marks : 4 Wrong Marks : 1

ধৰা হ'ল  $f(x) = \sin^{-1} x$  আৰু

$$g(x) = \frac{x^2 - x - 2}{2x^2 - x - 6} \text{ দুটা ফলন।}$$

যদি  $g(2) = \lim_{x \rightarrow 2} g(x)$  হয়, তেন্তে  $f \circ g$  ফলনটোৰ অদিক্ৰেত্ৰ হ'ব :

Options :

70819169183.  $(-\infty, -2] \cup \left[-\frac{3}{2}, \infty\right)$

70819169184.  $(-\infty, -2] \cup \left[-\frac{4}{3}, \infty\right)$

70819169185.  $(-\infty, -1] \cup [2, \infty)$

70819169186.  $(-\infty, -2] \cup [-1, \infty)$

Question Number : 70 Question Id : 70819121343 Question Type : MCQ Option Shuffling : Yes  
Is Question Mandatory : No

Correct Marks : 4 Wrong Marks : 1

Let A(1, 4) and B(1, -5) be two points. Let P be a point on the circle  $(x-1)^2 + (y-1)^2 = 1$  such that  $(PA)^2 + (PB)^2$  have maximum value, then the points, P, A and B lie on :

Options :

70819169187. an ellipse

70819169188. a hyperbola

70819169189. a parabola

70819169190. a straight line

**Question Number : 70 Question Id : 70819121343 Question Type : MCQ Option Shuffling : Yes**

**Is Question Mandatory : No**

**Correct Marks : 4 Wrong Marks : 1**

ধৰা হ'ল A(1, 4) আৰু B(1, -5) দুটা প্ৰদত্ত বিন্দু। যদি P বিন্দুটো  $(x-1)^2 + (y-1)^2 = 1$  বৃত্তৰ ওপৰত থাকে যাতে  $(PA)^2 + (PB)^2$  ৰ গৰিষ্ঠ মান আছে, তেন্তে P, A আৰু B বিন্দু তিনিটা থাকে :

**Options :**

70819169187. এটা উপবৃত্তৰ ওপৰত

70819169188. এটা পৰাবৃত্তৰ ওপৰত

70819169189. এটা অধিবৃত্তৰ ওপৰত

70819169190. এডাল সৰলৰেখাৰ ওপৰত

**Question Number : 71 Question Id : 70819121344 Question Type : MCQ Option Shuffling : Yes**

**Is Question Mandatory : No**

**Correct Marks : 4 Wrong Marks : 1**

If vectors  $\vec{a}_1 = x\hat{i} - \hat{j} + \hat{k}$  and  $\vec{a}_2 = \hat{i} + y\hat{j} + z\hat{k}$  are collinear, then a possible unit vector parallel to the vector  $x\hat{i} + y\hat{j} + z\hat{k}$  is :

**Options :**

70819169191.  $\frac{1}{\sqrt{2}} (-\hat{j} + \hat{k})$

70819169192.  $\frac{1}{\sqrt{3}} (\hat{i} - \hat{j} + \hat{k})$

70819169193.  $\frac{1}{\sqrt{3}} (\hat{i} + \hat{j} - \hat{k})$

70819169194.  $\frac{1}{\sqrt{2}} (\hat{i} - \hat{j})$

Question Number : 71 Question Id : 70819121344 Question Type : MCQ Option Shuffling : Yes

Is Question Mandatory : No

Correct Marks : 4 Wrong Marks : 1

যদি  $\vec{a}_1 = x\hat{i} - \hat{j} + \hat{k}$  আৰু  $\vec{a}_2 = \hat{i} + y\hat{j} + z\hat{k}$  দুটা একেৰেখীয় ভেক্টৰ, তেন্তে  $x\hat{i} + y\hat{j} + z\hat{k}$  ভেক্টৰটোৰ সমান্তৰাল হোৱাকৈ এটা সম্ভাৱ্য একক ভেক্টৰ হ'ব :

Options :

70819169191.  $\frac{1}{\sqrt{2}} (-\hat{j} + \hat{k})$

70819169192.  $\frac{1}{\sqrt{3}} (\hat{i} - \hat{j} + \hat{k})$

70819169193.  $\frac{1}{\sqrt{3}} (\hat{i} + \hat{j} - \hat{k})$

70819169194.  $\frac{1}{\sqrt{2}} (\hat{i} - \hat{j})$

Question Number : 72 Question Id : 70819121345 Question Type : MCQ Option Shuffling : Yes

Is Question Mandatory : No

Correct Marks : 4 Wrong Marks : 1

Let  $F_1(A, B, C) = (A \wedge \sim B) \vee [\sim C \wedge (A \vee B)] \vee \sim A$  and  $F_2(A, B) = (A \vee B) \vee (B \rightarrow \sim A)$  be two logical expressions. Then :

**Options :**

70819169195.  $F_1$  and  $F_2$  both are tautologies
70819169196.  $F_1$  is a tautology but  $F_2$  is not a tautology
70819169197.  $F_1$  is not a tautology but  $F_2$  is a tautology
70819169198. Both  $F_1$  and  $F_2$  are not tautologies

**Question Number : 72 Question Id : 70819121345 Question Type : MCQ Option Shuffling : Yes**

**Is Question Mandatory : No**

**Correct Marks : 4 Wrong Marks : 1**

ধরা হ'ল  $F_1(A, B, C) = (A \wedge \sim B) \vee [\sim C \wedge (A \vee B)] \vee \sim A$  আৰু  $F_2(A, B) = (A \vee B) \vee (B \rightarrow \sim A)$  দুটা যুক্তিযুক্ত বাণী (logical expressions)। তেন্তে :

**Options :**

70819169195.  $F_1$  আৰু  $F_2$  দুয়োটা পুনঃকল্পিত (tautologies)
70819169196.  $F_1$  পুনঃকল্পিত কিন্তু  $F_2$  পুনঃকল্পিত নহয়।
70819169197.  $F_1$  পুনঃকল্পিত নহয় কিন্তু  $F_2$  পুনঃকল্পিত হয়।
70819169198.  $F_1$  আৰু  $F_2$  দুয়োটাই পুনঃকল্পিত নহয়।

**Question Number : 73 Question Id : 70819121346 Question Type : MCQ Option Shuffling : Yes**

**Is Question Mandatory : No**

**Correct Marks : 4 Wrong Marks : 1**

A seven digit number is formed using digits 3, 3, 4, 4, 4, 5, 5. The probability that number so formed is divisible by 2, is :

**Options :**

70819169199.  $\frac{3}{7}$

70819169200.  $\frac{6}{7}$

70819169201.  $\frac{1}{7}$

70819169202.  $\frac{4}{7}$

**Question Number : 73 Question Id : 70819121346 Question Type : MCQ Option Shuffling : Yes**

**Is Question Mandatory : No**

**Correct Marks : 4 Wrong Marks : 1**

3,3,4,4,4,5,5 অংককেইটাৰে এটা সাত অংকীয়া সংখ্যা গঠন কৰা হ'ল। তেনেকৈ গঠন হোৱা 2 ৰে বিভাজ্য হোৱা সংখ্যা এটাৰ সম্ভাৱিতা হ'ব :

**Options :**

70819169199.  $\frac{3}{7}$

70819169200.  $\frac{6}{7}$

70819169201.  $\frac{1}{7}$

70819169202.  $\frac{4}{7}$

Question Number : 74 Question Id : 70819121347 Question Type : MCQ Option Shuffling : Yes

Is Question Mandatory : No

Correct Marks : 4 Wrong Marks : 1

Consider the following system of equations :

$$x + 2y - 3z = a$$

$$2x + 6y - 11z = b$$

$$x - 2y + 7z = c,$$

where a, b and c are real constants. Then the system of equations :

Options :

70819169203. has a unique solution for all a, b and c

70819169204. has a unique solution when  $5a = 2b + c$

70819169205. has infinite number of solutions when  $5a = 2b + c$

70819169206. has no solution for all a, b and c

Question Number : 74 Question Id : 70819121347 Question Type : MCQ Option Shuffling : Yes

Is Question Mandatory : No

Correct Marks : 4 Wrong Marks : 1

$$x + 2y - 3z = a$$

$$2x + 6y - 11z = b$$

$x - 2y + 7z = c$ , সমীকরণ প্রণালীটো লোৱা হ'ল, য'ত a, b, c বাস্তৱ ধ্ৰুৱক। তেন্তে প্ৰদত্ত সমীকৰণ  
প্ৰণালীটোৰ :

Options :

70819169203. সকলোবোৰ a, b আৰু c ৰ বাবে অদ্বিতীয় সমাধান আছে।

70819169204. যেতিয়া  $5a = 2b + c$ , তেতিয়া অদ্বিতীয় সমাধান আছে।

70819169205. অসীম সংখ্যক সমাধান থাকিব যেতিয়া  $5a = 2b + c$ ।

70819169206. সকলোবোৰ a, b আৰু c ৰ বাবে কোনো সমাধান নাথাকে।

Question Number : 75 Question Id : 70819121348 Question Type : MCQ Option Shuffling : Yes

Is Question Mandatory : No

Correct Marks : 4 Wrong Marks : 1

The triangle of maximum area that can be inscribed in a given circle of radius 'r' is :

Options :

70819169207. An isosceles triangle with base equal to 2r.

70819169208. A right angle triangle having two of its sides of length 2r and r.

70819169209. An equilateral triangle of height  $\frac{2r}{3}$ .

70819169210. An equilateral triangle having each of its side of length  $\sqrt{3} r$ .

Question Number : 75 Question Id : 70819121348 Question Type : MCQ Option Shuffling : Yes

Is Question Mandatory : No

Correct Marks : 4 Wrong Marks : 1

'r' ব্যাসার্ধৰ বৃত্ত এটাত গৰিষ্ঠ কালিৰ ত্ৰিভুজ এটা অন্তৰ্লেখিত কৰা যাব, যি :

Options :

70819169207. এটা সমদ্বিবাহু ত্ৰিভুজ যাৰ ভূমি 2r ।

70819169208. এটা সমকোণী ত্ৰিভুজ যাৰ দুটা বাহুৰ দৈৰ্ঘ্য ক্ৰমে 2r আৰু r ।

70819169209. এটা সমবাহু ত্ৰিভুজ যাৰ উচ্চতা  $\frac{2r}{3}$  ।

70819169210. এটা সমবাহু ত্ৰিভুজ যাৰ প্ৰতিটো বাহুৰ দৈৰ্ঘ্য  $\sqrt{3} r$ ।

**Question Number : 76 Question Id : 70819121349 Question Type : MCQ Option Shuffling : Yes**

**Is Question Mandatory : No**

**Correct Marks : 4 Wrong Marks : 1**

Let L be a line obtained from the intersection of two planes  $x + 2y + z = 6$  and  $y + 2z = 4$ . If point  $P(\alpha, \beta, \gamma)$  is the foot of perpendicular from  $(3, 2, 1)$  on L, then the value of  $21(\alpha + \beta + \gamma)$  equals :

**Options :**

70819169211. 68

70819169212. 102

70819169213. 136

70819169214. 142

**Question Number : 76 Question Id : 70819121349 Question Type : MCQ Option Shuffling : Yes**

**Is Question Mandatory : No**

**Correct Marks : 4 Wrong Marks : 1**

ধৰা হ'ল  $x + 2y + z = 6$  আৰু  $y + 2z = 4$  সমতল দুখনৰ ছেদনৰ পৰা প্ৰাপ্তি হোৱা L এডাল ৰেখা। যদি L ত  $(3, 2, 1)$  বিন্দুৰ লম্বৰ পাদবিন্দু  $P(\alpha, \beta, \gamma)$  হয়, তেন্তে  $21(\alpha + \beta + \gamma)$  ৰ মান হ'ব :

**Options :**

70819169211. 68

70819169212. 102

70819169213. 136

70819169214. 142

Question Number : 77 Question Id : 70819121350 Question Type : MCQ Option Shuffling : Yes

Is Question Mandatory : No

Correct Marks : 4 Wrong Marks : 1

Let  $f: \mathbb{R} \rightarrow \mathbb{R}$  be defined as

$$f(x) = \begin{cases} 2 \sin\left(-\frac{\pi x}{2}\right), & \text{if } x < -1 \\ ax^2 + x + b, & \text{if } -1 \leq x \leq 1 \\ \sin(\pi x), & \text{if } x > 1 \end{cases}$$

If  $f(x)$  is continuous on  $\mathbb{R}$ , then  $a + b$  equals :

Options :

70819169215. -3

70819169216. -1

70819169217. 1

70819169218. 3

Question Number : 77 Question Id : 70819121350 Question Type : MCQ Option Shuffling : Yes

Is Question Mandatory : No

Correct Marks : 4 Wrong Marks : 1

ধরা হ'ল  $f: \mathbb{R} \rightarrow \mathbb{R}$  এটা ফলন বর্ণিত আছে যাতে,

$$f(x) = \begin{cases} 2 \sin\left(-\frac{\pi x}{2}\right), & \text{যদি } x < -1 \\ ax^2 + x + b, & \text{যদি } -1 \leq x \leq 1 \\ \sin(\pi x), & \text{যদি } x > 1 \end{cases}$$

যদি  $\mathbb{R}$  ত  $f(x)$  ফলনটো অবিচ্ছিন্ন হয়, তেন্তে  $a + b$  সমান হ'ব :

Options :

70819169215.  $-3$

70819169216.  $-1$

70819169217.  $1$

70819169218.  $3$

Question Number : 78 Question Id : 70819121351 Question Type : MCQ Option Shuffling : Yes

Is Question Mandatory : No

Correct Marks : 4 Wrong Marks : 1

If the locus of the mid-point of the line segment from the point  $(3, 2)$  to a point on the circle,  $x^2 + y^2 = 1$  is a circle of radius  $r$ , then  $r$  is equal to :

Options :

70819169219.  $\frac{1}{4}$

70819169220.  $\frac{1}{3}$

70819169221.  $\frac{1}{2}$

70819169222.  $1$

Question Number : 78 Question Id : 70819121351 Question Type : MCQ Option Shuffling : Yes

Is Question Mandatory : No

Correct Marks : 4 Wrong Marks : 1

যদি  $x^2 + y^2 = 1$  বৃত্তৰ এটা বিন্দুলৈ  $(3, 2)$  বিন্দুৰ পৰা টনা বেখাখণ্ডটোৰ মধ্যবিন্দুৰ সঞ্চাৰপথ (locus)  $r$  ব্যাসৰিক্ষুণ্ড এটা বৃত্ত হয় তেন্তে  $r$  ৰ মান হ'ব :

**Options :**

70819169219.  $\frac{1}{4}$

70819169220.  $\frac{1}{3}$

70819169221.  $\frac{1}{2}$

70819169222. 1

**Question Number : 79 Question Id : 70819121352 Question Type : MCQ Option Shuffling : Yes**

**Is Question Mandatory : No**

**Correct Marks : 4 Wrong Marks : 1**

A natural number has prime factorization given by  $n = 2^x 3^y 5^z$ , where  $y$  and  $z$  are such that  $y + z = 5$  and  $y^{-1} + z^{-1} = \frac{5}{6}$ ,  $y > z$ . Then the number of odd divisors of  $n$ , including 1, is :

**Options :**

70819169223. 6

70819169224. 11

70819169225. 12

70819169226.  $6x$

**Question Number : 79 Question Id : 70819121352 Question Type : MCQ Option Shuffling : Yes**

Is Question Mandatory : No

Correct Marks : 4 Wrong Marks : 1

এটা স্বাভাবিক সংখ্যাৰ মৌলিক উৎপাদক বিশ্লেষণ  $n=2^x3^y5^z$  বুলি দিয়া আছে, য'ত  $y$  আৰু  $z$  এনেকুৱা যাতে,  
 $y+z=5$  আৰু  $y^{-1} + z^{-1} = \frac{5}{6}$ ,  $y > z$ , তেন্তে 1 ক ধৰি  $n$  ৰ অযুগ্ম উৎপাদকৰ সংখ্যা হ'ব :

Options :

70819169223. 6

70819169224. 11

70819169225. 12

70819169226.  $6x$

Question Number : 80 Question Id : 70819121353 Question Type : MCQ Option Shuffling : Yes

Is Question Mandatory : No

Correct Marks : 4 Wrong Marks : 1

For  $x > 0$ , if  $f(x) = \int_1^x \frac{\log_e t}{(1+t)} dt$ , then  $f(e) + f\left(\frac{1}{e}\right)$  is equal to :

Options :

70819169227. 0

70819169228. 1

70819169229.  $\frac{1}{2}$

70819169230. -1

Question Number : 80 Question Id : 70819121353 Question Type : MCQ Option Shuffling : Yes

Is Question Mandatory : No

Correct Marks : 4 Wrong Marks : 1

$x > 0$  বাবে, যদি  $f(x) = \int_1^x \frac{\log_e t}{(1+t)} dt$  তেন্তে  $f(e) + f\left(\frac{1}{e}\right)$  সমান হ'ব :

Options :

70819169227. 0

70819169228. 1

70819169229.  $\frac{1}{2}$

70819169230. -1

## Mathematics Section B

|                                       |            |
|---------------------------------------|------------|
| Section Id :                          | 708191963  |
| Section Number :                      | 6          |
| Section type :                        | Online     |
| Mandatory or Optional :               | Mandatory  |
| Number of Questions :                 | 10         |
| Number of Questions to be attempted : | 5          |
| Section Marks :                       | 20         |
| Mark As Answered Required? :          | Yes        |
| Sub-Section Number :                  | 1          |
| Sub-Section Id :                      | 7081911243 |
| Question Shuffling Allowed :          | Yes        |

Question Number : 81 Question Id : 70819121354 Question Type : SA

Correct Marks : 4 Wrong Marks : 0

If  $I_{m,n} = \int_0^1 x^{m-1}(1-x)^{n-1} dx$ , for  $m, n \geq 1$ , and  $\int_0^1 \frac{x^{m-1} + x^{n-1}}{(1+x)^{m+n}} dx = \alpha I_{m,n}$ ,  $\alpha \in \mathbb{R}$ , then  $\alpha$  equals \_\_\_\_\_.

Response Type : Numeric

Evaluation Required For SA : Yes

Show Word Count : Yes

Answers Type : Range

Text Areas : PlainText

Possible Answers :

5 to 5.001

Question Number : 81 Question Id : 70819121354 Question Type : SA

Correct Marks : 4 Wrong Marks : 0

যদি  $I_{m,n} = \int_0^1 x^{m-1}(1-x)^{n-1} dx$ ,  $m, n \geq 1$  আৰু  $\int_0^1 \frac{x^{m-1} + x^{n-1}}{(1+x)^{m+n}} dx = \alpha I_{m,n}$ ,  $\alpha \in \mathbb{R}$ , তেন্তে  $\alpha$  সমান হ'ব \_\_\_\_\_।

Response Type : Numeric

Evaluation Required For SA : Yes

Show Word Count : Yes

Answers Type : Range

Text Areas : PlainText

Possible Answers :

5 to 5.001

Question Number : 82 Question Id : 70819121355 Question Type : SA

Correct Marks : 4 Wrong Marks : 0

Let  $z$  be those complex numbers which satisfy

$$|z+5| \leq 4 \text{ and } z(1+i) + \bar{z}(1-i) \geq -10, i = \sqrt{-1}.$$

If the maximum value of  $|z+1|^2$  is  $\alpha + \beta\sqrt{2}$ , then the value of  $(\alpha + \beta)$  is \_\_\_\_\_.

**Response Type :** Numeric

**Evaluation Required For SA :** Yes

**Show Word Count :** Yes

**Answers Type :** Range

**Text Areas :** PlainText

**Possible Answers :**

5 to 5.001

**Question Number :** 82 **Question Id :** 70819121355 **Question Type :** SA

**Correct Marks :** 4 **Wrong Marks :** 0

ধৰা হ'ল  $|z+5| \leq 4$  আৰু  $z(1+i) + \bar{z}(1-i) \geq -10, i = \sqrt{-1}$ , অসমীকৰণ দুটাক সিদ্ধ কৰা  $z$  এটা জটিল সংখ্যা। যদি  $|z+1|^2$  ৰ গৰিষ্ঠ মান  $\alpha + \beta\sqrt{2}$  হয়, তেন্তে  $(\alpha + \beta)$  ৰ মান হ'ব \_\_\_\_\_।

**Response Type :** Numeric

**Evaluation Required For SA :** Yes

**Show Word Count :** Yes

**Answers Type :** Range

**Text Areas :** PlainText

**Possible Answers :**

5 to 5.001

**Question Number :** 83 **Question Id :** 70819121356 **Question Type :** SA

**Correct Marks :** 4 **Wrong Marks :** 0

Let the normals at all the points on a given curve pass through a fixed point  $(a, b)$ . If the curve passes through  $(3, -3)$  and  $(4, -2\sqrt{2})$ , and given that  $a - 2\sqrt{2}b = 3$ , then  $(a^2 + b^2 + ab)$  is equal to \_\_\_\_\_.

**Response Type :** Numeric

**Evaluation Required For SA :** Yes

Show Word Count : Yes

Answers Type : Range

Text Areas : PlainText

Possible Answers :

5 to 5.001

Question Number : 83 Question Id : 70819121356 Question Type : SA

Correct Marks : 4 Wrong Marks : 0

ধৰা হ'ল এটা প্রদত্ত বক্রৰ প্রত্যেক বিন্দুত টা অভিলম্ববোৰে এটা নির্দিষ্ট বিন্দু  $(a, b)$  ৰ মাজেৰে পাৰ হৈ যায়। যদি বক্রটোৱে  $(3, -3)$  আৰু  $(4, -2\sqrt{2})$  বিন্দুৰে পাৰ হয় আৰু  $a - 2\sqrt{2}b = 3$  হয়, তেন্তে  $(a^2 + b^2 + ab)$  ৰ মান হ'ব \_\_\_\_\_।

Response Type : Numeric

Evaluation Required For SA : Yes

Show Word Count : Yes

Answers Type : Range

Text Areas : PlainText

Possible Answers :

5 to 5.001

Question Number : 84 Question Id : 70819121357 Question Type : SA

Correct Marks : 4 Wrong Marks : 0

Let  $a$  be an integer such that all the real roots of the polynomial  $2x^5 + 5x^4 + 10x^3 + 10x^2 + 10x + 10$  lie in the interval  $(a, a + 1)$ .  
Then,  $|a|$  is equal to \_\_\_\_\_.

Response Type : Numeric

Evaluation Required For SA : Yes

Show Word Count : Yes

Answers Type : Range

Text Areas : PlainText

Possible Answers :

**Question Number : 84 Question Id : 70819121357 Question Type : SA**

**Correct Marks : 4 Wrong Marks : 0**

ধৰা হ'ল  $a$  এটা অখণ্ড সংখ্যা যাতে  $2x^5 + 5x^4 + 10x^3 + 10x^2 + 10x + 10$  বহুপদটোৰ আটাইবোৰ বাস্তৱ মূল  $(a, a+1)$  অন্তৰালত থাকে। তেন্তে  $|a|$  সমান হ'ব :

**Response Type : Numeric**

**Evaluation Required For SA : Yes**

**Show Word Count : Yes**

**Answers Type : Range**

**Text Areas : PlainText**

**Possible Answers :**

5 to 5.001

**Question Number : 85 Question Id : 70819121358 Question Type : SA**

**Correct Marks : 4 Wrong Marks : 0**

Let  $X_1, X_2, \dots, X_{18}$  be eighteen observations such that  $\sum_{i=1}^{18} (X_i - \alpha) = 36$  and  $\sum_{i=1}^{18} (X_i - \beta)^2 = 90$ ,

where  $\alpha$  and  $\beta$  are distinct real numbers. If the standard deviation of these observations is 1, then the value of  $|\alpha - \beta|$  is \_\_\_\_\_.

**Response Type : Numeric**

**Evaluation Required For SA : Yes**

**Show Word Count : Yes**

**Answers Type : Range**

**Text Areas : PlainText**

**Possible Answers :**

5 to 5.001

**Question Number : 85 Question Id : 70819121358 Question Type : SA**

**Correct Marks : 4 Wrong Marks : 0**

ধৰা হ'ল  $X_1, X_2, \dots, X_{18}$  ক্ৰমে 18টা পৰ্য্যবেক্ষণ যাতে  $\sum_{i=1}^{18} (X_i - \alpha) = 36$  আৰু  $\sum_{i=1}^{18} (X_i - \beta)^2 = 90$ , য'ত  $\alpha$

আৰু  $\beta$  দুটা ভিন্ন বাস্তৱ সংখ্যা। যদি এইবোৰ পৰ্য্যবেক্ষণৰ প্ৰামাণিক বিচ্যুতি 1 হয়, তেন্তে  $|\alpha - \beta|$  ৰ মান হ'ব \_\_\_\_\_।

**Response Type :** Numeric

**Evaluation Required For SA :** Yes

**Show Word Count :** Yes

**Answers Type :** Range

**Text Areas :** PlainText

**Possible Answers :**

5 to 5.001

**Question Number :** 86 **Question Id :** 70819121359 **Question Type :** SA

**Correct Marks :** 4 **Wrong Marks :** 0

If the matrix  $A = \begin{bmatrix} 1 & 0 & 0 \\ 0 & 2 & 0 \\ 3 & 0 & -1 \end{bmatrix}$  satisfies the equation  $A^{20} + \alpha A^{19} + \beta A = \begin{bmatrix} 1 & 0 & 0 \\ 0 & 4 & 0 \\ 0 & 0 & 1 \end{bmatrix}$  for some

real numbers  $\alpha$  and  $\beta$ , then  $\beta - \alpha$  is equal to \_\_\_\_\_.

**Response Type :** Numeric

**Evaluation Required For SA :** Yes

**Show Word Count :** Yes

**Answers Type :** Range

**Text Areas :** PlainText

**Possible Answers :**

5 to 5.001

**Question Number :** 86 **Question Id :** 70819121359 **Question Type :** SA

**Correct Marks :** 4 **Wrong Marks :** 0

$\alpha$  আৰু  $\beta$  ৰ কিছুমান বাস্তৱ মানৰ বাবে যদি  $A = \begin{bmatrix} 1 & 0 & 0 \\ 0 & 2 & 0 \\ 3 & 0 & -1 \end{bmatrix}$  মৌলিকস্ফটোৱে  $A^{20} + \alpha A^{19} + \beta A = \begin{bmatrix} 1 & 0 & 0 \\ 0 & 4 & 0 \\ 0 & 0 & 1 \end{bmatrix}$

সমীকৰণটোক সিদ্ধ কৰে তেন্তে,  $\beta - \alpha$  সমান হ'ব \_\_\_\_\_।

**Response Type :** Numeric

**Evaluation Required For SA :** Yes

**Show Word Count :** Yes

**Answers Type :** Range

**Text Areas :** PlainText

**Possible Answers :**

5 to 5.001

**Question Number :** 87 **Question Id :** 70819121360 **Question Type :** SA

**Correct Marks :** 4 **Wrong Marks :** 0

Let  $\alpha$  and  $\beta$  be two real numbers such that  $\alpha + \beta = 1$  and  $\alpha\beta = -1$ . Let  $p_n = (\alpha)^n + (\beta)^n$ ,  $p_{n-1} = 11$  and  $p_{n+1} = 29$  for some integer  $n \geq 1$ . Then, the value of  $p_n^2$  is \_\_\_\_\_.

**Response Type :** Numeric

**Evaluation Required For SA :** Yes

**Show Word Count :** Yes

**Answers Type :** Range

**Text Areas :** PlainText

**Possible Answers :**

5 to 5.001

**Question Number :** 87 **Question Id :** 70819121360 **Question Type :** SA

**Correct Marks :** 4 **Wrong Marks :** 0

ধৰা হ'ল  $\alpha$  আৰু  $\beta$  দুটা বাস্তৱ সংখ্যা যত  $\alpha + \beta = 1$  আৰু  $\alpha\beta = -1$  হয়। ধৰা হ'ল  $p_n = (\alpha)^n + (\beta)^n$ ,  $p_{n-1} = 11$  আৰু  $p_{n+1} = 29$ , কিছুমান অখণ্ড সংখ্যা  $n \geq 1$ , ৰ বাবে। তেন্তে  $p_n^2$  ৰ মান হ'ব \_\_\_\_\_।

**Response Type :** Numeric

**Evaluation Required For SA :** Yes

Show Word Count : Yes

Answers Type : Range

Text Areas : PlainText

Possible Answers :

5 to 5.001

Question Number : 88 Question Id : 70819121361 Question Type : SA

Correct Marks : 4 Wrong Marks : 0

The total number of 4-digit numbers whose greatest common divisor with 18 is 3, is \_\_\_\_\_.

Response Type : Numeric

Evaluation Required For SA : Yes

Show Word Count : Yes

Answers Type : Range

Text Areas : PlainText

Possible Answers :

5 to 5.001

Question Number : 88 Question Id : 70819121361 Question Type : SA

Correct Marks : 4 Wrong Marks : 0

18 ব লগত গঃ সাঃ উঃ (GCD) 3 হোৱাকৈ 4-অংকীয়া মুঠ সংখ্যা হ'ব \_\_\_\_\_।

Response Type : Numeric

Evaluation Required For SA : Yes

Show Word Count : Yes

Answers Type : Range

Text Areas : PlainText

Possible Answers :

5 to 5.001

Question Number : 89 Question Id : 70819121362 Question Type : SA

**Correct Marks : 4 Wrong Marks : 0**

If the arithmetic mean and geometric mean of the  $p^{\text{th}}$  and  $q^{\text{th}}$  terms of the sequence  $-16, 8, -4, 2, \dots$  satisfy the equation  $4x^2 - 9x + 5 = 0$ , then  $p + q$  is equal to \_\_\_\_\_.

**Response Type : Numeric**

**Evaluation Required For SA : Yes**

**Show Word Count : Yes**

**Answers Type : Range**

**Text Areas : PlainText**

**Possible Answers :**

5 to 5.001

**Question Number : 89 Question Id : 70819121362 Question Type : SA**

**Correct Marks : 4 Wrong Marks : 0**

যদি,  $-16, 8, -4, 2, \dots$  প্রগতিটোৰ  $p$  তম আৰু  $q$  তম পদ দুটাৰ সমান্তৰ মাধ্য (A.M.) আৰু গুণোত্তৰ মাধ্য (G.M.) য়ে  $4x^2 - 9x + 5 = 0$  সমীকৰণক সিদ্ধ কৰে, তেন্তে  $p + q$  সমান হ'ব \_\_\_\_\_।

**Response Type : Numeric**

**Evaluation Required For SA : Yes**

**Show Word Count : Yes**

**Answers Type : Range**

**Text Areas : PlainText**

**Possible Answers :**

5 to 5.001

**Question Number : 90 Question Id : 70819121363 Question Type : SA**

**Correct Marks : 4 Wrong Marks : 0**

Let  $L$  be a common tangent line to the curves  $4x^2 + 9y^2 = 36$  and  $(2x)^2 + (2y)^2 = 31$ . Then the square of the slope of the line  $L$  is \_\_\_\_\_.

**Response Type : Numeric**

**Evaluation Required For SA : Yes**

**Show Word Count : Yes**

**Answers Type : Range**

**Text Areas :** PlainText

**Possible Answers :**

5 to 5.001

**Question Number : 90 Question Id : 70819121363 Question Type : SA**

**Correct Marks : 4 Wrong Marks : 0**

ধৰা হ'ল  $4x^2 + 9y^2 = 36$  আৰু  $(2x)^2 + (2y)^2 = 31$ , বক্ৰ দুটাৰ L এদাল সাধাৰণ স্পৰ্শক। তেন্তে L বেখাডালৰ প্ৰৱণতাৰ বৰ্গ হ'ব \_\_\_\_\_.

**Response Type :** Numeric

**Evaluation Required For SA :** Yes

**Show Word Count :** Yes

**Answers Type :** Range

**Text Areas :** PlainText

**Possible Answers :**

5 to 5.001