

National Testing Agency

Question Paper Name :	B TECH EA 18th March 2021 Shift 2
Subject Name :	B TECH EA
Creation Date :	2021-03-18 19:51:24
Duration :	180
Number of Questions :	90
Total Marks :	300
Display Marks:	Yes

B TECH EA

Group Number :	1
Group Id :	86435165
Group Maximum Duration :	0
Group Minimum Duration :	180
Show Attended Group? :	No
Edit Attended Group? :	No
Break time :	0
Group Marks :	300
Is this Group for Examiner? :	No

Physics Section A

Section Id :	864351385
Section Number :	1
Section type :	Online
Mandatory or Optional :	Mandatory
Number of Questions :	20
Number of Questions to be attempted :	20
Section Marks :	80
Mark As Answered Required? :	Yes
Sub-Section Number :	1
Sub-Section Id :	864351385
Question Shuffling Allowed :	Yes

Question Number : 1 Question Id : 8643515761 Question Type : MCQ Option Shuffling : Yes Is Question Mandatory : No Correct Marks : 4 Wrong Marks : 1

Consider a sample of oxygen behaving like an ideal gas. At 300 K, the ratio of root mean square (rms) velocity to the average velocity of gas molecule would be :

(Molecular weight of oxygen is 32 g/mol; $R = 8.3 \text{ J K}^{-1} \text{ mol}^{-1}$)

Options :

86435117281. $\sqrt{\frac{3\pi}{8}}$

86435117282. $\sqrt{\frac{8\pi}{3}}$

86435117283. $\sqrt{\frac{8}{3}}$

86435117284. $\sqrt{\frac{3}{3}}$

Question Number : 1 Question Id : 8643515761 Question Type : MCQ Option Shuffling : Yes Is Question Mandatory : No

Correct Marks : 4 Wrong Marks : 1

এক আদৰ্শ গেছৰ দৰে আচৰণ কৰা অক্সিজেনৰ এক নমুনা বিচাৰ কৰা। 300 K ত, গেছ অণুসমূহৰ গড় বৰ্গ মূল বেগৰ সৈতে গড় বেগৰ অনুপাত হ'ব :

(অক্সিজেনৰ আণৱিক ভৰ 32 g/mol; $R = 8.3 \text{ J K}^{-1} \text{ mol}^{-1}$)

Options :

86435117281. $\sqrt{\frac{3\pi}{8}}$

86435117282. $\sqrt{\frac{8\pi}{3}}$

86435117283. $\sqrt{\frac{8}{3}}$

86435117284. $\sqrt{\frac{3}{3}}$

Question Number : 2 Question Id : 8643515762 Question Type : MCQ Option Shuffling : Yes Is Question Mandatory : No Correct Marks : 4 Wrong Marks : 1

An object of mass m_1 collides with another object of mass m_2 , which is at rest. After the collision the objects move with equal speeds in opposite direction. The ratio of the masses $m_2 : m_1$ is :

Options :

86435117285. 1 : 1

86435117286. 1 : 2

86435117287. 2 : 1

86435117288. 3 : 1

Question Number : 2 Question Id : 8643515762 Question Type : MCQ Option Shuffling : Yes Is Question Mandatory : No Correct Marks : 4 Wrong Marks : 1

m_1 ভৰৰ এটা বস্তুৰ m_2 ভৰৰ অন্য এটা স্থিৰ অৱস্থাত থকা বস্তুৰ সৈতে সংঘৰ্ষ হয়। সংঘৰ্ষৰ পাছত বস্তুদুটাই সমান দ্ৰুতিৰে বিপৰীত দিশত গতি কৰে। ভৰসমূহৰ অনুপাত $m_2 : m_1$ হয় :

Options :

86435117285. 1 : 1

86435117286. 1 : 2

86435117287. 2 : 1

86435117288. 3 : 1

Question Number : 3 Question Id : 8643515763 Question Type : MCQ Option Shuffling : Yes Is Question Mandatory : No Correct Marks : 4 Wrong Marks : 1

A particle of mass m moves in a circular orbit under the central potential field, $U(r) = -\frac{C}{r}$,

where C is a positive constant.

The correct radius – velocity graph of the particle's motion is :

Options :

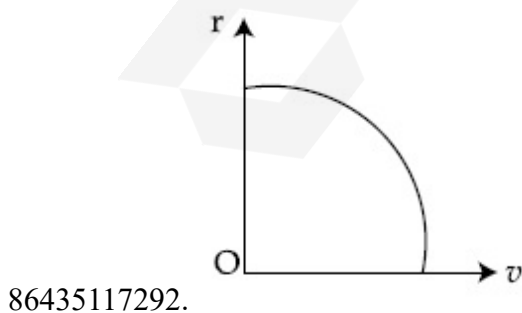
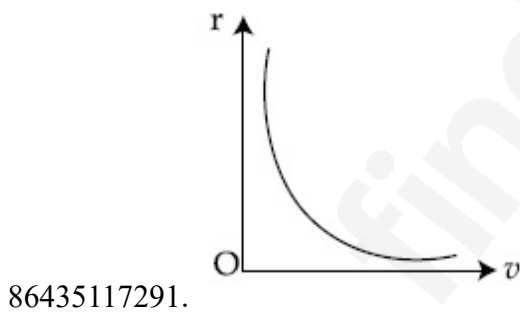
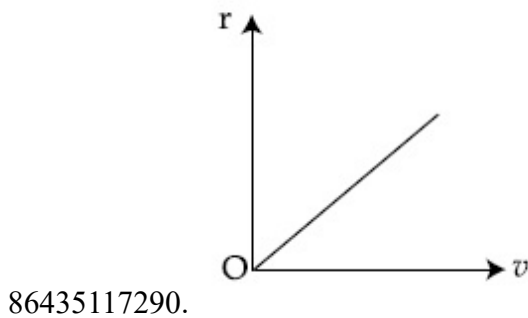
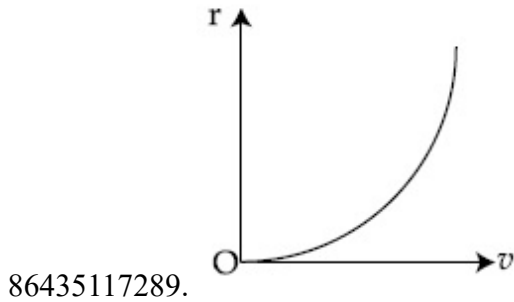

Question Number : 3 Question Id : 8643515763 Question Type : MCQ Option Shuffling : Yes Is Question Mandatory : No

Correct Marks : 4 Wrong Marks : 1

কেন্দ্রীয় বিভৱ ক্ষেত্ৰ, $U(r) = -\frac{C}{r}$ ত, য'ত C এটা ধনাত্মক ধ্ৰুৱক, m ভৰৰ এটা কণাই বৃত্তাকাৰ কক্ষপথত গতি কৰে।

কণাটোৰ গতিৰ শুদ্ধ ব্যাসাৰ্ধ বেগ ৰেখাচিত্ৰ হয় :

Options :

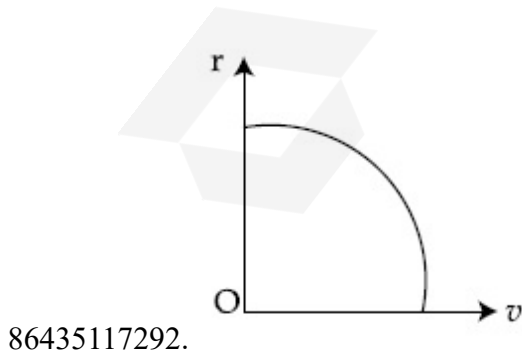
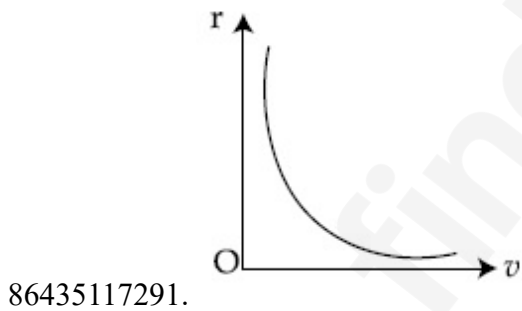
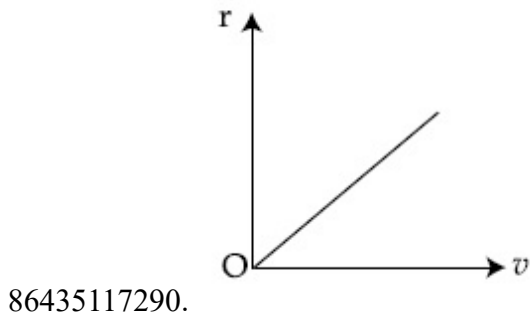
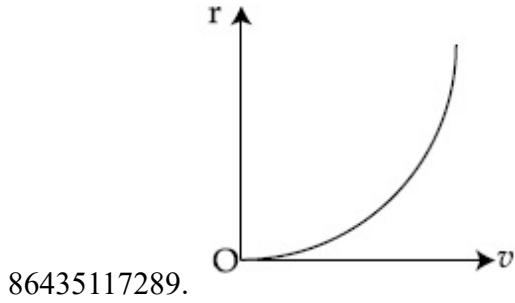

Question Number : 4 Question Id : 8643515764 Question Type : MCQ Option Shuffling : Yes Is Question Mandatory : No

Correct Marks : 4 Wrong Marks : 1

A solid cylinder of mass m is wrapped with an inextensible light string and, is placed on a rough inclined plane as shown in the figure. The frictional force acting between the cylinder and the inclined plane is :

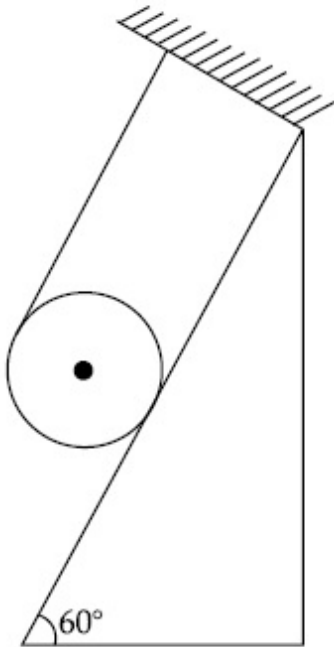

[The coefficient of static friction, μ_s , is 0.4]

Options :

86435117293. $\frac{mg}{5}$

86435117294. $5 mg$

86435117295. $\frac{7}{2} mg$

86435117296. 0

Question Number : 4 Question Id : 8643515764 Question Type : MCQ Option Shuffling : Yes Is Question Mandatory : No

Correct Marks : 4 Wrong Marks : 1

এডাল সম্প্রসাৰণ কৰিব নোৱাৰা পাতল সূতাৰে m ভৰৰ এটা গোটা চুঙা মেৰিয়াই তাক চিত্ৰত দেখুওৱা ধৰণে এখন বন্ধ হেলনীয়া তলত ৰখা হ'ল। চুঙাটো আৰু হেলনীয়া তলখনৰ মাজত ক্ৰিয়া কৰা ঘৰ্ষণবল হয় :

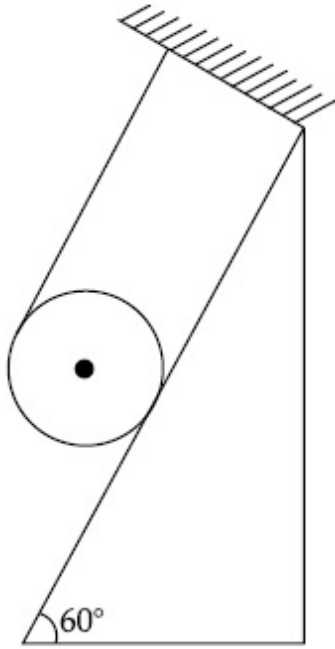

[স্থৈতিক ঘৰ্ষণ গুণাংক μ_s is 0.4]

Options :

86435117293. $\frac{mg}{5}$

86435117294. $5 mg$

86435117295. $\frac{7}{2} mg$

86435117296. 0

Question Number : 5 Question Id : 8643515765 Question Type : MCQ Option Shuffling : Yes Is Question Mandatory : No

Correct Marks : 4 Wrong Marks : 1

If the angular velocity of earth's spin is increased such that the bodies at the equator start floating, the duration of the day would be approximately :

[Take $g = 10 \text{ ms}^{-2}$, the radius of earth, $R = 6400 \times 10^3 \text{ m}$, Take $\pi = 3.14$]

Options :

86435117297. does not change

86435117298. 1200 minutes

86435117299. 60 minutes

86435117300. 84 minutes

Question Number : 5 Question Id : 8643515765 Question Type : MCQ Option Shuffling : Yes Is Question Mandatory : No

Correct Marks : 4 Wrong Marks : 1

যদিহে পৃথিৱীৰ ঘূৰ্ণনৰ কৌণিক বেগ বৃদ্ধি কৰা হয় যাতে বিষুৱৰেখাত থকা বস্তুসমূহ ওপঙিবলৈ আৰম্ভ কৰে, এটা দিনৰ সময়কাল মোটামুটিভাৱে হ'বগৈ :

[$g = 10 \text{ ms}^{-2}$, পৃথিৱীৰ ব্যাসার্ধ $R = 6400 \times 10^3 \text{ m}$, $\pi = 3.14$ লোৱা]

Options :

86435117297. সলনি নহয়

86435117298. 1200 minutes

86435117299. 60 minutes

86435117300. 84 minutes

Question Number : 6 Question Id : 8643515766 Question Type : MCQ Option Shuffling : Yes Is Question Mandatory : No

Correct Marks : 4 Wrong Marks : 1

Consider a uniform wire of mass M and length L . It is bent into a semicircle. Its moment of inertia about a line perpendicular to the plane of the wire passing through the centre is :

Options :

86435117301. $\frac{ML^2}{\pi^2}$

86435117302. $\frac{1}{2} \frac{ML^2}{\pi^2}$

$$86435117303. \quad \frac{1}{4} \frac{ML^2}{\pi^2}$$

$$86435117304. \quad \frac{2}{5} \frac{ML^2}{\pi^2}$$

Question Number : 6 Question Id : 8643515766 Question Type : MCQ Option Shuffling : Yes Is Question Mandatory : No

Correct Marks : 4 Wrong Marks : 1

ভৰ M আৰু দৈৰ্ঘ্য L ৰ এডাল সুযম তাঁৰ বিবেচনা কৰা। ইয়াক এটা অৰ্ধবৃত্তৰ ৰূপত বেঁকা কৰা হ'ল। তাঁৰ ডালৰ তলখনৰ লম্বভাৱে আৰু কেন্দ্ৰৰ মাজেদি যোৱা এডাল ৰেখা সাপেক্ষে ইয়াৰ জড় ভ্ৰামক হয় :

Options :

$$86435117301. \quad \frac{ML^2}{\pi^2}$$

$$86435117302. \quad \frac{1}{2} \frac{ML^2}{\pi^2}$$

$$86435117303. \quad \frac{1}{4} \frac{ML^2}{\pi^2}$$

$$86435117304. \quad \frac{2}{5} \frac{ML^2}{\pi^2}$$

Question Number : 7 Question Id : 8643515767 Question Type : MCQ Option Shuffling : Yes Is Question Mandatory : No

Correct Marks : 4 Wrong Marks : 1

The speed of electrons in a scanning electron microscope is $1 \times 10^7 \text{ ms}^{-1}$. If the protons having the same speed are used instead of electrons, then the resolving power of scanning proton microscope will be changed by a factor of :

Options :

$$86435117305. \quad 1837$$

86435117306. $\frac{1}{1837}$

86435117307. $\frac{1}{\sqrt{1837}}$

86435117308. $\sqrt{1837}$

Question Number : 7 Question Id : 8643515767 Question Type : MCQ Option Shuffling : Yes Is Question Mandatory : No

Correct Marks : 4 Wrong Marks : 1

এটা স্কেনিং ইলেক্ট্ৰন মাইক্ৰ'স্কপত ইলেক্ট্ৰনৰ দ্ৰুতি হয় $1 \times 10^7 \text{ ms}^{-1}$ । যদিহে ইলেক্ট্ৰনৰ সলনি একেই দ্ৰুতি সম্পন্ন প্ৰ'টন ব্যৱহাৰ কৰা হয়, তেতিয়া স্কেনিং প্ৰ'টন মাইক্ৰ'স্কপৰ বিভেদন ক্ষমতা সলনিৰ গুণক হ'ব :

Options :

86435117305. 1837

86435117306. $\frac{1}{1837}$

86435117307. $\frac{1}{\sqrt{1837}}$

86435117308. $\sqrt{1837}$

Question Number : 8 Question Id : 8643515768 Question Type : MCQ Option Shuffling : Yes Is Question Mandatory : No

Correct Marks : 4 Wrong Marks : 1

The velocity - displacement graph of a particle is shown in the figure.

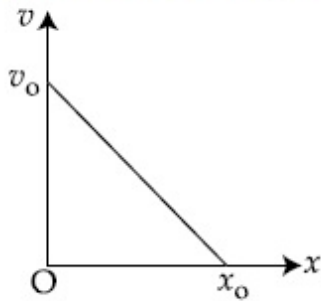

The acceleration - displacement graph of the same particle is represented by :

Options :

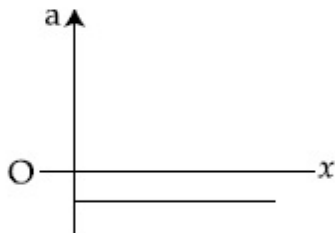

86435117309.

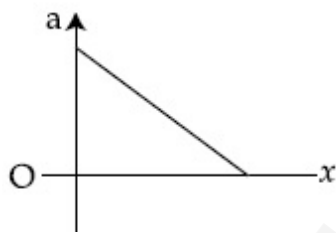

86435117310.

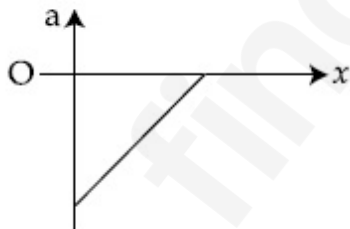

86435117311.

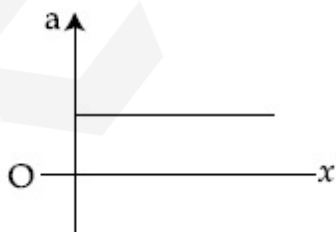

86435117312.

Question Number : 8 Question Id : 8643515768 Question Type : MCQ Option Shuffling : Yes Is Question Mandatory : No

Correct Marks : 4 Wrong Marks : 1

এটা কণাৰ বেগ-সৰণ বেখাচিত্ৰ চিত্ৰত দেখুওৱা হৈছে :

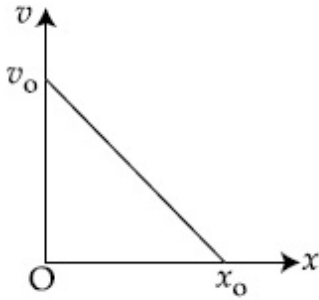

একেটা কণাৰ ত্বৰণ-সৰণ বেখাচিত্ৰ দৰ্শোৱা যাব :

Options :

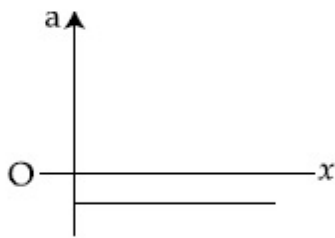

86435117309.

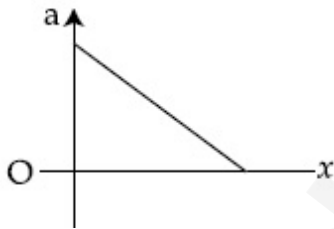

86435117310.

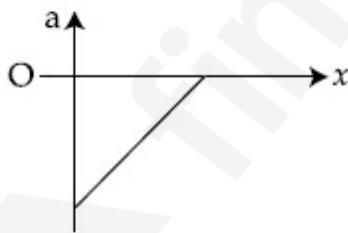

86435117311.

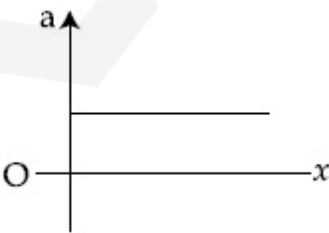

86435117312.

Question Number : 9 Question Id : 8643515769 Question Type : MCQ Option Shuffling : Yes Is

Question Mandatory : No

Correct Marks : 4 Wrong Marks : 1

For an adiabatic expansion of an ideal gas, the fractional change in its pressure is equal to (where γ is the ratio of specific heats) :

Options :

$$-\gamma \frac{dV}{V}$$

86435117313.

$$-\gamma \frac{V}{dV}$$

86435117314.

$$-\frac{1}{\gamma} \frac{dV}{V}$$

86435117315.

$$\frac{dV}{V}$$

86435117316.

Question Number : 9 Question Id : 8643515769 Question Type : MCQ Option Shuffling : Yes Is

Question Mandatory : No

Correct Marks : 4 Wrong Marks : 1

এটা আদৰ্শ গেছৰ তাপবোধী প্ৰসাৰণৰ বাবে, ইয়াৰ চাপৰ আংশিক পৰিবৰ্তন সমান হয় (য'ত γ আপেক্ষিক তাপসমূহৰ অনুপাত) :

Options :

$$-\gamma \frac{dV}{V}$$

86435117313.

$$-\gamma \frac{V}{dV}$$

86435117314.

$$-\frac{1}{\gamma} \frac{dV}{V}$$

86435117315.

$$86435117316. \frac{dV}{V}$$

Question Number : 10 Question Id : 8643515770 Question Type : MCQ Option Shuffling : Yes Is

Question Mandatory : No

Correct Marks : 4 Wrong Marks : 1

The angular momentum of a planet of mass M moving around the sun in an elliptical orbit is

\vec{L} . The magnitude of the areal velocity of the planet is :

Options :

$$86435117317. \frac{L}{M}$$

$$86435117318. \frac{L}{2M}$$

$$86435117319. \frac{2L}{M}$$

$$86435117320. \frac{4L}{M}$$

Question Number : 10 Question Id : 8643515770 Question Type : MCQ Option Shuffling : Yes Is

Question Mandatory : No

Correct Marks : 4 Wrong Marks : 1

এটা উপবৃত্তাকাৰ কক্ষপথত সূৰ্য্যৰ চাৰিওফালে গতি কৰি থকা M ভৰৰ এটা গ্ৰহৰ কৌণিক ভৰবেগ \vec{L} । গ্ৰহটোৰ ক্ষেত্ৰীয় বেগৰ মান হয় :

Options :

$$86435117317. \frac{L}{M}$$

$$86435117318. \frac{L}{2M}$$

$$86435117319. \frac{2L}{M}$$

$$86435117320. \frac{4L}{M}$$

Question Number : 11 Question Id : 8643515771 Question Type : MCQ Option Shuffling : Yes Is Question Mandatory : No

Correct Marks : 4 Wrong Marks : 1

An ideal gas in a cylinder is separated by a piston in such a way that the entropy of one part is S_1 and that of the other part is S_2 . Given that $S_1 > S_2$. If the piston is removed then the total entropy of the system will be :

Options :

$$86435117321. S_1 \times S_2$$

$$86435117322. S_1 - S_2$$

$$86435117323. S_1 + S_2$$

$$86435117324. \frac{S_1}{S_2}$$

Question Number : 11 Question Id : 8643515771 Question Type : MCQ Option Shuffling : Yes Is Question Mandatory : No

Correct Marks : 4 Wrong Marks : 1

এটা চূড়াত থকা এক আদৰ্শ গেছক এটা পিষ্টনৰ সহায়ত এনেদৰে পৃথক কৰা হৈছে যাতে এভাগৰ এন্ট্রপী S_1 হয় আৰু আনভাগৰ এন্ট্রপী S_2 হয়। দিয়া আছে $S_1 > S_2$ । যদি পিষ্টনটো আঁতৰাই দিয়া হয় নিকায়টোৰ মুঠ এন্ট্রপী হ'ব :

Options :

$$86435117321. S_1 \times S_2$$

$$86435117322. S_1 - S_2$$

$$86435117323. S_1 + S_2$$

$$86435117324. \frac{S_1}{S_2}$$

Question Number : 12 Question Id : 8643515772 Question Type : MCQ Option Shuffling : Yes Is Question Mandatory : No Correct Marks : 4 Wrong Marks : 1

The function of time representing a simple harmonic motion with a period of $\frac{\pi}{\omega}$ is :

Options :

$$86435117325. \sin(\omega t) + \cos(\omega t)$$

$$86435117326. \sin^2(\omega t)$$

$$86435117327. 3 \cos\left(\frac{\pi}{4} - 2\omega t\right)$$

$$86435117328. \cos(\omega t) + \cos(2\omega t) + \cos(3\omega t)$$

Question Number : 12 Question Id : 8643515772 Question Type : MCQ Option Shuffling : Yes Is Question Mandatory : No Correct Marks : 4 Wrong Marks : 1

পর্যায়কাল $\frac{\pi}{\omega}$ ৰ এটা সৰল পৰ্যাবৃত্ত গতিক দৰ্শোৱা সময়ৰ ফলন হয় :

Options :

$$86435117325. \sin(\omega t) + \cos(\omega t)$$

$$86435117326. \sin^2(\omega t)$$

$$86435117327. 3 \cos\left(\frac{\pi}{4} - 2\omega t\right)$$

$$86435117328. \cos(\omega t) + \cos(2\omega t) + \cos(3\omega t)$$

Question Number : 13 Question Id : 8643515773 Question Type : MCQ Option Shuffling : Yes Is

Question Mandatory : No

Correct Marks : 4 Wrong Marks : 1

In a series LCR circuit, the inductive reactance (X_L) is 10Ω and the capacitive reactance (X_C) is 4Ω . The resistance (R) in the circuit is 6Ω .

The power factor of the circuit is :

Options :

86435117329. $\frac{1}{\sqrt{2}}$

86435117330. $\frac{\sqrt{3}}{2}$

86435117331. $\frac{1}{2}$

86435117332. $\frac{1}{2\sqrt{2}}$

Question Number : 13 Question Id : 8643515773 Question Type : MCQ Option Shuffling : Yes Is

Question Mandatory : No

Correct Marks : 4 Wrong Marks : 1

এটা শ্রেণীবদ্ধ LCR বর্তনীত, আবেশীয় প্রতিবোধ (X_L) 10Ω আৰু ধাৰকীয় প্রতিবোধ (X_C) 4Ω । বর্তনীটোত বোধ (R) 6Ω । বর্তনীটোৰ ক্ষমতা গুণক হয় :

Options :

86435117329. $\frac{1}{\sqrt{2}}$

86435117330. $\frac{\sqrt{3}}{2}$

86435117331. $\frac{1}{2}$

86435117332. $\frac{1}{2\sqrt{2}}$

Question Number : 14 Question Id : 8643515774 Question Type : MCQ Option Shuffling : Yes Is Question Mandatory : No Correct Marks : 4 Wrong Marks : 1

Which of the following statements are correct ?

- (A) Electric monopoles do not exist whereas magnetic monopoles exist.
- (B) Magnetic field lines due to a solenoid at its ends and outside cannot be completely straight and confined.
- (C) Magnetic field lines are completely confined within a toroid.
- (D) Magnetic field lines inside a bar magnet are not parallel.
- (E) $\chi = -1$ is the condition for a perfect diamagnetic material, where χ is its magnetic susceptibility.

Choose the correct answer from the options given below :

Options :

86435117333. (B) and (D) only

86435117334. (B) and (C) only

86435117335. (A) and (B) only

86435117336. (C) and (E) only

Question Number : 14 Question Id : 8643515774 Question Type : MCQ Option Shuffling : Yes Is Question Mandatory : No Correct Marks : 4 Wrong Marks : 1

তলৰ কোনবোৰ উক্তি শুদ্ধ ?

- (A) বৈদ্যুতিক একমেৰুৰ অস্তিত্ব নাই য'ত নেকি চুম্বকীয় একমেৰুৰ অস্তিত্ব আছে।
- (B) এটা চলেনইডৰ বাবে চৌম্বিক ক্ষেত্র বেখাসমূহ ইয়াৰ প্ৰান্তত আৰু ইয়াৰ বাহিৰত সম্পূৰ্ণ ৰূপে সৰলবৈখিক আৰু আবদ্ধ হ'ব নোৱাৰে।
- (C) এটা টৰইডৰ ভিতৰত চৌম্বিক ক্ষেত্র বেখাসমূহ সম্পূৰ্ণৰূপে আবদ্ধ।
- (D) এডাল দণ্ড চুম্বকৰ ভিতৰত চৌম্বিক ক্ষেত্র বেখাসমূহ সমান্তৰাল নহয়।
- (E) এটা বিশুদ্ধ অপচুম্বকীয় পদাৰ্থৰ বাবে চৰ্ত হয় $\chi = -1$, য'ত χ চৌম্বিক প্ৰৱণতা।

তলৰ বিকল্পৰ পৰা শুদ্ধ উত্তৰ চয়ন কৰা :

Options :

86435117333. (B) আৰু (D) কেৱল

86435117334. (B) আৰু (C) কেৱল

86435117335. (A) আৰু (B) কেৱল

86435117336. (C) আৰু (E) কেৱল

Question Number : 15 Question Id : 8643515775 Question Type : MCQ Option Shuffling : Yes Is Question Mandatory : No

Correct Marks : 4 Wrong Marks : 1

The correct relation between α (ratio of collector current to emitter current) and β (ratio of collector current to base current) of a transistor is :

Options :

86435117337.
$$\beta = \frac{\alpha}{1 + \alpha}$$

86435117338.
$$\alpha = \frac{\beta}{1 - \alpha}$$

86435117339.
$$\beta = \frac{1}{1 - \alpha}$$

$$\alpha = \frac{\beta}{1 + \beta}$$

86435117340.

Question Number : 15 Question Id : 8643515775 Question Type : MCQ Option Shuffling : Yes Is

Question Mandatory : No

Correct Marks : 4 Wrong Marks : 1

এটা ট্ৰেঞ্জিষ্টৰৰ α (কালেক্টৰ প্ৰবাহৰ সৈতে এমিটাৰ প্ৰবাহৰ অনুপাত) আৰু β (কালেক্টৰ প্ৰবাহৰ সৈতে বেছ প্ৰবাহৰ অনুপাত) ৰ মাজৰ শুদ্ধ সম্বন্ধ হ'ল :

Options :

$$\beta = \frac{\alpha}{1 + \alpha}$$

86435117337.

$$\alpha = \frac{\beta}{1 - \alpha}$$

86435117338.

$$\beta = \frac{1}{1 - \alpha}$$

86435117339.

$$\alpha = \frac{\beta}{1 + \beta}$$

86435117340.

Question Number : 16 Question Id : 8643515776 Question Type : MCQ Option Shuffling : Yes Is

Question Mandatory : No

Correct Marks : 4 Wrong Marks : 1

A proton and an α -particle, having kinetic energies K_p and K_α respectively, enter into a magnetic field at right angles.

The ratio of the radii of trajectory of proton to that of α -particle is 2 : 1. The ratio of $K_p : K_\alpha$ is :

Options :

86435117341. 1 : 4

86435117342. 4 : 1

86435117343. 8 : 1

86435117344. 1 : 8

Question Number : 16 Question Id : 8643515776 Question Type : MCQ Option Shuffling : Yes Is Question Mandatory : No

Correct Marks : 4 Wrong Marks : 1

ক্রমে গতি-শক্তি K_p আৰু K_α থকা এটা প্ৰ'টন আৰু α -কণাই এখন চৌম্বিক ক্ষেত্ৰত সমকোণীয়াকৈ প্ৰবেশ কৰে। প্ৰট'নটোৰ সৈতে α -কণাটোৰ প্ৰক্ষেপ-পথৰ ব্যাসাৰ্ধৰ অনুপাত হয় 2 : 1। অনুপাত $K_p : K_\alpha$ হয় :

Options :

86435117341. 1 : 4

86435117342. 4 : 1

86435117343. 8 : 1

86435117344. 1 : 8

Question Number : 17 Question Id : 8643515777 Question Type : MCQ Option Shuffling : Yes Is Question Mandatory : No

Correct Marks : 4 Wrong Marks : 1

Three rays of light, namely red (R), green (G) and blue (B) are incident on the face PQ of a right angled prism PQR as shown in the figure.

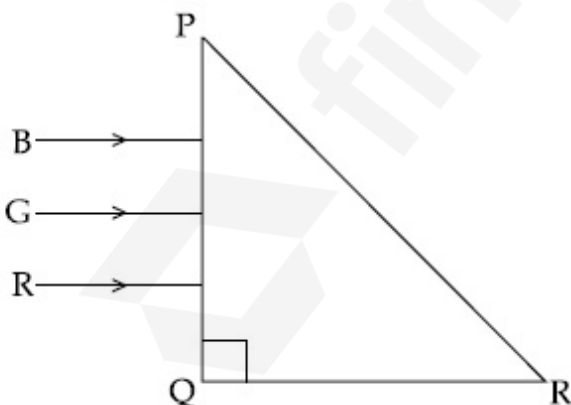

The refractive indices of the material of the prism for red, green and blue wavelength are 1.27, 1.42 and 1.49 respectively. The colour of the ray(s) emerging out of the face PR is :

Options :

86435117345. blue and green

86435117346. blue

86435117347. green

86435117348. red

Question Number : 17 Question Id : 8643515777 Question Type : MCQ Option Shuffling : Yes Is Question Mandatory : No

Correct Marks : 4 Wrong Marks : 1

এটা সমকোণী ত্ৰিভুজ PQR ৰ PQ পৃষ্ঠত তিনিটা বশি, বঙা (R), সেউজীয়া (G) আৰু নীলা (B) চিত্ৰত দেখুওৱা ধৰণে আপতিত হৈছে।

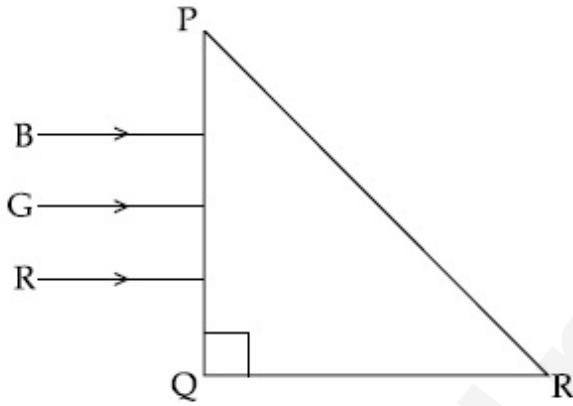

বঙা, সেউজীয়া আৰু নীলা তৰংগ দৈৰ্ঘ্যৰ বাবে ত্ৰিভুজৰ পদাৰ্থৰ প্ৰতিসৰাংকসমূহ ক্ৰমে 1.27, 1.42 আৰু 1.49। পৃষ্ঠ PR ৰ পৰা নিৰ্গত বশিসমূহৰ বঙা হ'ব :

Options :

86435117345. নীলা আৰু সেউজীয়া

86435117346. নীলা

86435117347. সেউজীয়া

86435117348. বঙা

Question Number : 18 Question Id : 8643515778 Question Type : MCQ Option Shuffling : Yes Is Question Mandatory : No

Correct Marks : 4 Wrong Marks : 1

The time taken for the magnetic energy to reach 25% of its maximum value, when a solenoid of resistance R, inductance L is connected to a battery, is :

Options :

86435117349. $\frac{L}{R} \ln 2$

86435117350. $\frac{L}{R} \ln 5$

86435117351. $\frac{L}{R} \ln 10$

86435117352. infinite

Question Number : 18 Question Id : 8643515778 Question Type : MCQ Option Shuffling : Yes Is Question Mandatory : No

Correct Marks : 4 Wrong Marks : 1

যেতিয়া এটা বেটেৰীৰ সৈতে R ৰোধ, L আৱেশৰ এটা চলেনইড সংযোগ কৰা হয়, চৌম্বিক শক্তি ইয়াৰ সৰ্বোচ্চ মানৰ 25% পাবলৈ লগা সময় হয় :

Options :

86435117349. $\frac{L}{R} \ln 2$

86435117350. $\frac{L}{R} \ln 5$

86435117351. $\frac{L}{R} \ln 10$

86435117352. অসীম

Question Number : 19 Question Id : 8643515779 Question Type : MCQ Option Shuffling : Yes Is Question Mandatory : No

Correct Marks : 4 Wrong Marks : 1

A plane electromagnetic wave propagating along y -direction can have the following pair of electric field (\vec{E}) and magnetic field (\vec{B}) components.

Options :

86435117353. E_y, B_y or E_z, B_z

86435117354. E_x, B_y or E_y, B_x

86435117355. E_x, B_z or E_z, B_x

86435117356. E_y, B_x or E_x, B_y

Question Number : 19 Question Id : 8643515779 Question Type : MCQ Option Shuffling : Yes Is

Question Mandatory : No

Correct Marks : 4 Wrong Marks : 1

y -দিশত সঞ্চালিত এটা সমতলীয় বিদ্যুৎ চুম্বকীয় তৰংগই তলত দিয়া বৈদ্যুতিক ক্ষেত্র (\vec{E}) আৰু চৌম্বিক ক্ষেত্র (\vec{B}) ৰ

অংশৰ যোৰটো ল'ব পাৰে।

Options :

86435117353. E_y, B_y or E_z, B_z

86435117354. E_x, B_y or E_y, B_x

86435117355. E_x, B_z or E_z, B_x

86435117356. E_y, B_x or E_x, B_y

Question Number : 20 Question Id : 8643515780 Question Type : MCQ Option Shuffling : Yes Is

Question Mandatory : No

Correct Marks : 4 Wrong Marks : 1

The decay of a proton to neutron is :

Options :

86435117357. not possible as proton mass is less than the neutron mass

86435117358. possible only inside the nucleus

86435117359. always possible as it is associated only with β^+ decay

86435117360. not possible but neutron to proton conversion is possible

Question Number : 20 Question Id : 8643515780 Question Type : MCQ Option Shuffling : Yes Is Question Mandatory : No

Correct Marks : 4 Wrong Marks : 1

এটা প্র'ট'নৰ নিউট্রনলৈ বিঘটন :

Options :

86435117357. সম্ভৱ নহয় যিহেতু প্র'ট'নৰ ভৰ নিউট্রনৰ ভৰতকৈ কম।

86435117358. কেৱল নিউক্লিয়াছৰ ভিতৰতহে সম্ভৱ।

86435117359. সদায়েই সম্ভৱ যিহেতু ই কেৱল β^+ বিঘটনৰ সৈতে জড়িত।

86435117360. সম্ভৱ নহয় কিন্তু নিউট্রনৰ পৰা প্র'ট'নলৈ পৰিবৰ্তন সম্ভৱ।

Physics Section B

Section Id :	864351386
Section Number :	2
Section type :	Online
Mandatory or Optional :	Mandatory
Number of Questions :	10
Number of Questions to be attempted :	5
Section Marks :	20
Mark As Answered Required? :	Yes
Sub-Section Number :	1
Sub-Section Id :	864351386
Question Shuffling Allowed :	Yes

Question Number : 21 Question Id : 8643515781 Question Type : SA

Correct Marks : 4 Wrong Marks : 0

The projectile motion of a particle of mass 5 g is shown in the figure.



The initial velocity of the particle is $5\sqrt{2} \text{ ms}^{-1}$ and the air resistance is assumed to be negligible.

The magnitude of the change in momentum between the points A and B is $x \times 10^{-2} \text{ kgms}^{-1}$.

The value of x , to the nearest integer, is _____.

Response Type : Numeric

Evaluation Required For SA : Yes

Show Word Count : Yes

Answers Type : Equal

Text Areas : PlainText

Possible Answers :

100

Question Number : 21 Question Id : 8643515781 Question Type : SA

Correct Marks : 4 Wrong Marks : 0

চিত্রত 5 g ভৰৰ এটা কণাৰ প্ৰক্ষেপণ গতি দেখুওৱা হৈছে।

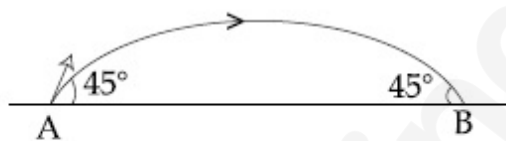

কণাটোৰ প্ৰাৰম্ভিক বেগ $5\sqrt{2} \text{ ms}^{-1}$ আৰু বায়ুৰ ৰোধ নগন্য বুলি ধৰা হৈছে। A আৰু B বিন্দুৰ মাজত ভৰবেগৰ পৰিবৰ্তনৰ মান $x \times 10^{-2} \text{ kgms}^{-1}$ । x ৰ মান, নিকটতম পূৰ্ণসংখ্যালৈ _____।

Response Type : Numeric

Evaluation Required For SA : Yes

Show Word Count : Yes

Answers Type : Equal

Text Areas : PlainText

Possible Answers :

100

Question Number : 22 Question Id : 8643515782 Question Type : SA

Correct Marks : 4 Wrong Marks : 0

An infinite number of point charges, each carrying $1 \mu\text{C}$ charge, are placed along the y -axis at $y = 1 \text{ m}, 2 \text{ m}, 4 \text{ m}, 8 \text{ m}, \dots$

The total force on a 1 C point charge, placed at the origin, is $x \times 10^3 \text{ N}$.

The value of x , to the nearest integer, is _____.

[Take $\frac{1}{4\pi\epsilon_0} = 9 \times 10^9 \text{ Nm}^2/\text{C}^2$]

Response Type : Numeric

Evaluation Required For SA : Yes

Show Word Count : Yes

Answers Type : Equal

Text Areas : PlainText

Possible Answers :

100

Question Number : 22 **Question Id :** 8643515782 **Question Type :** SA

Correct Marks : 4 **Wrong Marks :** 0

y -অক্ষৰ দিশত, $y = 1 \text{ m}, 2 \text{ m}, 4 \text{ m}, 8 \text{ m}, \dots$ ত, প্ৰত্যেকেই $1 \mu\text{C}$ আধান কঢ়িওৱা, অসীম সংখ্যক বিন্দুসম আধান ৰখা হৈছে।

মূলবিন্দুত ৰখা 1 C বিন্দুসম আধানত মুঠ বল হয় $x \times 10^3 \text{ N}$ ।

x ৰ মান, নিকটতম পূৰ্ণসংখ্যালৈ _____।

[$\frac{1}{4\pi\epsilon_0} = 9 \times 10^9 \text{ Nm}^2/\text{C}^2$ লোৱা]

Response Type : Numeric

Evaluation Required For SA : Yes

Show Word Count : Yes

Answers Type : Equal

Text Areas : PlainText

Possible Answers :

100

Question Number : 23 **Question Id :** 8643515783 **Question Type :** SA

Correct Marks : 4 **Wrong Marks :** 0

Two wires of same length and thickness having specific resistances $6 \Omega \text{ cm}$ and $3 \Omega \text{ cm}$ respectively are connected in parallel. The effective resistivity is $\rho \Omega \text{ cm}$. The value of ρ , to the nearest integer, is _____.

Response Type : Numeric

Evaluation Required For SA : Yes

Show Word Count : Yes

Answers Type : Equal

Text Areas : PlainText

Possible Answers :

100

Question Number : 23 Question Id : 8643515783 Question Type : SA

Correct Marks : 4 Wrong Marks : 0

ক্রমে আপেক্ষিক বোধ $6 \Omega \text{ cm}$ আৰু $3 \Omega \text{ cm}$ সম্পন্ন দুডাল একেই দৈৰ্ঘ্য আৰু ডাঠ থকা তাঁৰক সমান্তৰালভাৱে সংযোগ কৰা হৈছে। প্ৰভাৱী বোধতা (effective resistivity) $\rho \Omega \text{ cm}$ । ρ ৰ মান, নিকটতম পূৰ্ণসংখ্যালৈ, _____।

Response Type : Numeric

Evaluation Required For SA : Yes

Show Word Count : Yes

Answers Type : Equal

Text Areas : PlainText

Possible Answers :

100

Question Number : 24 Question Id : 8643515784 Question Type : SA

Correct Marks : 4 Wrong Marks : 0

A ball of mass 4 kg , moving with a velocity of 10 ms^{-1} , collides with a spring of length 8 m and force constant 100 Nm^{-1} . The length of the compressed spring is $x \text{ m}$. The value of x , to the nearest integer, is _____.

Response Type : Numeric

Evaluation Required For SA : Yes

Show Word Count : Yes

Answers Type : Equal

Text Areas : PlainText

Possible Answers :

100

Question Number : 24 Question Id : 8643515784 Question Type : SA

Correct Marks : 4 Wrong Marks : 0

10 ms^{-1} বেগেৰে গতি কৰি থকা 4 kg ভৰৰ এটা বলে, বল ধ্ৰুৱক 100 Nm^{-1} আৰু দৈৰ্ঘ্য 8 m ৰ এডাল স্প্ৰিংৰ সৈতে সংঘাত কৰে। সংকোচিত স্প্ৰিং ডালৰ দৈৰ্ঘ্য হয় $x \text{ m}$ । x ৰ মান, নিকটতম পূৰ্ণসংখ্যালৈ, _____।

Response Type : Numeric

Evaluation Required For SA : Yes

Show Word Count : Yes

Answers Type : Equal

Text Areas : PlainText

Possible Answers :

100

Question Number : 25 Question Id : 8643515785 Question Type : SA

Correct Marks : 4 Wrong Marks : 0

The typical output characteristics curve for a transistor working in the common-emitter configuration is shown in the figure.

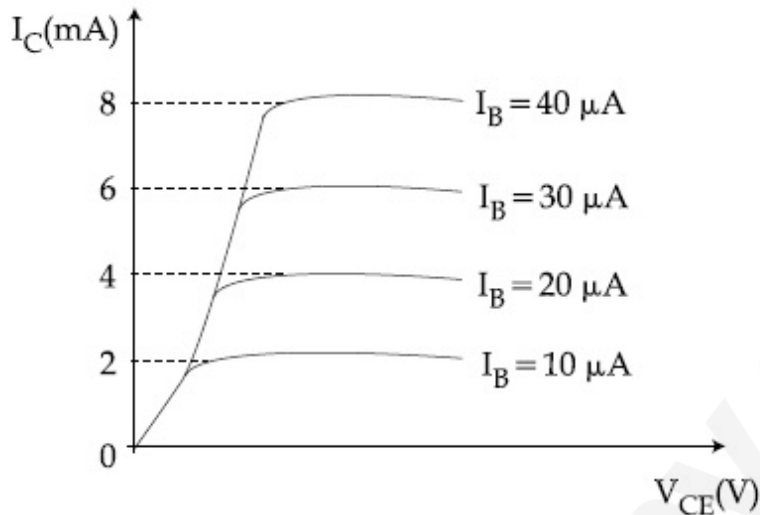

The estimated current gain from the figure is _____.

Response Type : Numeric

Evaluation Required For SA : Yes

Show Word Count : Yes

Answers Type : Equal

Text Areas : PlainText

Possible Answers :

100

Question Number : 25 Question Id : 8643515785 Question Type : SA

Correct Marks : 4 Wrong Marks : 0

চিত্রত কমন এমিটাৰ (common-emitter) বিন্যাসত কাম কৰি থকা এটা আদৰ্শ ট্ৰেঞ্জিষ্টৰৰ বৈশিষ্ট্য লেখ দেখুওৱা হৈছে।

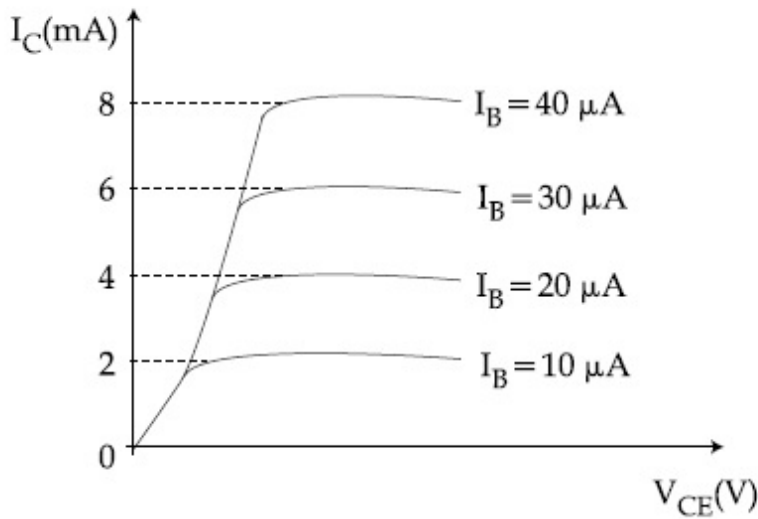

চিত্ৰৰ পৰা গণনা কৰা প্ৰবাহ পৰিবৰ্ধন (current gain) _____।

Response Type : Numeric

Evaluation Required For SA : Yes

Show Word Count : Yes

Answers Type : Equal

Text Areas : PlainText

Possible Answers :

100

Question Number : 26 **Question Id :** 8643515786 **Question Type :** SA

Correct Marks : 4 **Wrong Marks :** 0

Consider a 72 cm long wire AB as shown in the figure. The galvanometer jockey is placed at P on AB at a distance x cm from A. The galvanometer shows zero deflection.

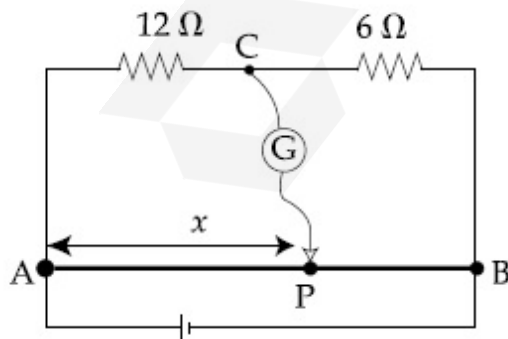

The value of x , to the nearest integer, is _____.

Response Type : Numeric

Evaluation Required For SA : Yes

Show Word Count : Yes

Answers Type : Equal

Text Areas : PlainText

Possible Answers :

100

Question Number : 26 **Question Id :** 8643515786 **Question Type :** SA

Correct Marks : 4 **Wrong Marks :** 0

চিত্রত দেখুওৱা ধৰণে এডাল 72 cm দৈৰ্ঘ্যৰ তাঁৰ AB বিবেচনা কৰা। A ৰ পৰা x cm দূৰত্বত AB ৰ P বিন্দুত গেলভেন'মিটাৰ জকিটো বন্ধা হৈছে। গেলভেন'মিটাৰটোৱে শূন্য বিক্ষিপণ দেখুৱাইছে।

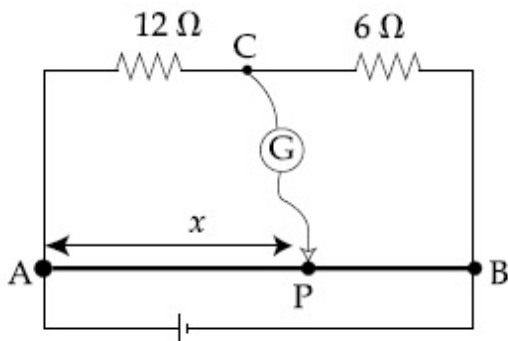

x ৰ মান, নিকটতম পূৰ্ণসংখ্যালৈ, _____।

Response Type : Numeric

Evaluation Required For SA : Yes

Show Word Count : Yes

Answers Type : Equal

Text Areas : PlainText

Possible Answers :

100

Question Number : 27 **Question Id :** 8643515787 **Question Type :** SA

Correct Marks : 4 **Wrong Marks :** 0

A galaxy is moving away from the earth at a speed of 286 kms^{-1} . The shift in the wavelength of a redline at 630 nm is $x \times 10^{-10} \text{ m}$.

The value of x , to the nearest integer, is _____.

[Take the value of speed of light c , as $3 \times 10^8 \text{ ms}^{-1}$]

Response Type : Numeric

Evaluation Required For SA : Yes

Show Word Count : Yes

Answers Type : Equal

Text Areas : PlainText

Possible Answers :

100

Question Number : 27 Question Id : 8643515787 Question Type : SA

Correct Marks : 4 Wrong Marks : 0

286 kms^{-1} দ্রুতিৰে এটা গেলেক্সিয়ে পৃথিৱীৰ পৰা দূৰলৈ গৈ আছে। 630 nm ত থকা এটা ৰঙা ৰেখাৰ (Red line) তৰংগদৈৰ্ঘ্যৰ বিছ্ৰাপন (shift) $x \times 10^{-10} \text{ m}$ ।

x ৰ মান, নিকটতম পূৰ্ণসংখ্যালৈ, _____।

[পোহৰৰ দ্রুতিৰ মান, $c = 3 \times 10^8 \text{ ms}^{-1}$ লোৱা]

Response Type : Numeric

Evaluation Required For SA : Yes

Show Word Count : Yes

Answers Type : Equal

Text Areas : PlainText

Possible Answers :

100

Question Number : 28 Question Id : 8643515788 Question Type : SA

Correct Marks : 4 Wrong Marks : 0

Consider a water tank as shown in the figure. It's cross-sectional area is 0.4 m^2 . The tank has an opening B near the bottom whose cross-section area is 1 cm^2 . A load of 24 kg is applied on the water at the top when the height of the water level is 40 cm above the bottom, the velocity of water coming out the opening B is $v \text{ ms}^{-1}$.

The value of v , to the nearest integer, is _____.

[Take value of g to be 10 ms^{-2}]

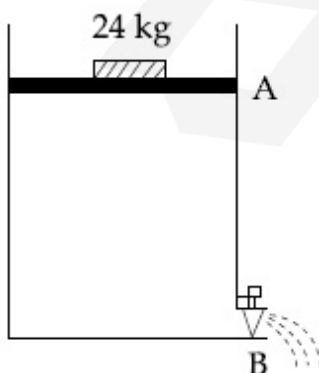

Response Type : Numeric

Evaluation Required For SA : Yes

Show Word Count : Yes

Answers Type : Equal

Text Areas : PlainText

Possible Answers :

100

Question Number : 28 Question Id : 8643515788 Question Type : SA

Correct Marks : 4 Wrong Marks : 0

চিত্ৰত দেখুওৱা ধৰণে এটা পানীৰ টেংকি বিবেচনা কৰা। ইয়াৰ পৃষ্ঠছেদৰ কালি 0.4 m^2 । টেংকিটোৰ তলিত ওচৰত এটা B ফুটা আছে যাৰ পৃষ্ঠছেদৰ কালি 1 cm^2 । যেতিয়া তলিৰ পৰা পানীস্তৰৰ উচ্চতা 40 cm হয়, পানীৰ ওপৰত 24 kg ৰ এক ওজন দিয়া হয়, B ফুটাটোৰ পৰা ওলাই অহা পানীৰ বেগ $v \text{ ms}^{-1}$ । v ৰ মান, নিকটতম পূৰ্ণসংখ্যালৈ _____।

[g ৰ মান 10 ms^{-2} লোৱা]

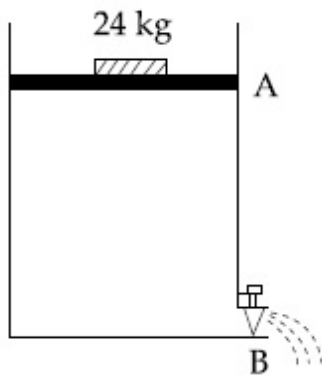

Response Type : Numeric

Evaluation Required For SA : Yes

Show Word Count : Yes

Answers Type : Equal

Text Areas : PlainText

Possible Answers :

100

Question Number : 29 Question Id : 8643515789 Question Type : SA

Correct Marks : 4 Wrong Marks : 0

A TV transmission tower antenna is at a height of 20 m . Suppose that the receiving antenna is at.

- (i) ground level
- (ii) a height of 5 m .

The increase in antenna range in case (ii) relative to case (i) is $n\%$.

The value of n , to the nearest integer, is _____.

Response Type : Numeric

Evaluation Required For SA : Yes

Show Word Count : Yes

Answers Type : Equal

Text Areas : PlainText

Possible Answers :

100

Question Number : 29 Question Id : 8643515789 Question Type : SA

Correct Marks : 4 Wrong Marks : 0

এটা TV প্ৰেৰক স্তম্ভৰ এণ্টেনা 20 m উচ্চতাত আছে। ধৰি লোৱা যে গ্ৰাহক এণ্টেনা,

(i) ভূমি স্তৰ

(ii) 5 m উচ্চতাত আছে

কেচ (i) সাপেক্ষে কেচ (ii) ত এণ্টেনাৰ পৰিসৰৰ বৃদ্ধি $n\%$ ।

n ৰ মান, নিকটতম পূৰ্ণসংখ্যালৈ _____।

Response Type : Numeric

Evaluation Required For SA : Yes

Show Word Count : Yes

Answers Type : Equal

Text Areas : PlainText

Possible Answers :

100

Question Number : 30 Question Id : 8643515790 Question Type : SA

Correct Marks : 4 Wrong Marks : 0

The radius of a sphere is measured to be (7.50 ± 0.85) cm. Suppose the percentage error in its volume is x .

The value of x , to the nearest x , is _____.

Response Type : Numeric

Evaluation Required For SA : Yes

Show Word Count : Yes

Answers Type : Equal

Text Areas : PlainText

Possible Answers :

100

Question Number : 30 Question Id : 8643515790 Question Type : SA

Correct Marks : 4 Wrong Marks : 0

গোলক এটাৰ ব্যাসার্ধ মাপ কৰি পোৱা গ'ল (7.50 ± 0.85) cm । ধৰা, ইয়াৰ আয়তনত শতকৰা ভাগটো x ।

x ৰ মান, নিকটতম পূৰ্ণসংখ্যালৈ _____ ।

Response Type : Numeric

Evaluation Required For SA : Yes

Show Word Count : Yes

Answers Type : Equal

Text Areas : PlainText

Possible Answers :

100

Chemistry Section A

Section Id :	864351387
Section Number :	3
Section type :	Online
Mandatory or Optional :	Mandatory
Number of Questions :	20
Number of Questions to be attempted :	20
Section Marks :	80
Mark As Answered Required? :	Yes
Sub-Section Number :	1
Sub-Section Id :	864351387
Question Shuffling Allowed :	Yes

Question Number : 31 Question Id : 8643515791 Question Type : MCQ Option Shuffling : Yes Is Question Mandatory : No

Correct Marks : 4 Wrong Marks : 1

A hard substance melts at high temperature and is an insulator in both solid and in molten state. This solid is most likely to be a/an :

Options :

86435117371. Ionic solid

86435117372. Covalent solid

86435117373. Metallic solid

86435117374. Molecular solid

Question Number : 31 Question Id : 8643515791 Question Type : MCQ Option Shuffling : Yes Is Question Mandatory : No

Correct Marks : 4 Wrong Marks : 1

এটা টান পদার্থ উচ্চ উষ্ণতাত গলে আৰু কঠিন আৰু গলিত দুয়োটা অৱস্থাত অপৰিবাহী। কঠিনটো হোৱাৰ সম্ভাৱনা হ'ল :

Options :

86435117371. আয়নীয় কঠিন

86435117372. সহযোজী কঠিন

86435117373. ধাতবীয় কঠিন

86435117374. আনবীয় কঠিন

Question Number : 32 Question Id : 8643515792 Question Type : MCQ Option Shuffling : Yes Is Question Mandatory : No

Correct Marks : 4 Wrong Marks : 1

Given below are two statements :

Statement I : Bohr's theory accounts for the stability and line spectrum of Li^+ ion.

Statement II : Bohr's theory was unable to explain the splitting of spectral lines in the presence of a magnetic field.

In the light of the above statements, choose the most appropriate answer from the options given below :

Options :

86435117375. Both statement I and statement II are true.

86435117376. Both statement I and statement II are false.

86435117377. Statement I is true but statement II is false.

86435117378. Statement I is false but statement II is true.

Question Number : 32 Question Id : 8643515792 Question Type : MCQ Option Shuffling : Yes Is Question Mandatory : No

Correct Marks : 4 Wrong Marks : 1

তলত দুটা উক্তি দিয়া হ'ল :

উক্তি I : ব'ৰৰ সূত্ৰই Li^+ আয়নৰ সুস্থিৰতা আৰু বৈখিক বৰ্ণালীৰ কাৰণ দৰ্শায়।

উক্তি II : ব'ৰৰ সূত্ৰই চুম্বকীয় ক্ষেত্ৰৰ উপস্থিতিত বৰ্ণালী বেখাৰ বিদাৰণ (splitting) বৰ্ণনা কৰিবলৈ অসমৰ্থ।

ওপৰৰ উক্তিৰ আলমত, তলত দিয়া বিকল্পৰপৰা আটাইতকৈ উপযুক্ত উত্তৰটো বাছি উলিওৱা :

Options :

86435117375. উক্তি I আৰু উক্তি II দুয়োটা সত্য।

86435117376. উক্তি I আৰু উক্তি II দুয়োটা অসত্য।

86435117377. উক্তি I সত্য কিন্তু উক্তি II অসত্য।

86435117378. উক্তি I অসত্য কিন্তু উক্তি II সত্য।

Question Number : 33 Question Id : 8643515793 Question Type : MCQ Option Shuffling : Yes Is

Question Mandatory : No

Correct Marks : 4 Wrong Marks : 1

The charges on the colloidal CdS sol and TiO_2 sol are, respectively :

Options :

86435117379. positive and positive

86435117380. negative and positive

86435117381. positive and negative

86435117382. negative and negative

Question Number : 33 Question Id : 8643515793 Question Type : MCQ Option Shuffling : Yes Is

Question Mandatory : No

Correct Marks : 4 Wrong Marks : 1

কলয়ড CdS ছ'ল আৰু TiO_2 ছ'লত থকা আধানৰ সংখ্যা যথাক্ৰমে হ'ল :

Options :

86435117379. ধনাত্মক আৰু ধনাত্মক

86435117380. ঋণাত্মক আৰু ধনাত্মক

86435117381. ধনাত্মক আৰু ঋণাত্মক

86435117382. ঋণাত্মক আৰু ঋণাত্মক

Question Number : 34 Question Id : 8643515794 Question Type : MCQ Option Shuffling : Yes Is Question Mandatory : No Correct Marks : 4 Wrong Marks : 1

The first ionization energy of magnesium is smaller as compared to that of elements X and Y, but higher than that of Z. The elements X, Y and Z, respectively, are :

Options :

86435117383. argon, chlorine and sodium

86435117384. chlorine, lithium and sodium

86435117385. argon, lithium and sodium

86435117386. neon, sodium and chlorine

Question Number : 34 Question Id : 8643515794 Question Type : MCQ Option Shuffling : Yes Is Question Mandatory : No Correct Marks : 4 Wrong Marks : 1

মেগনেছিয়ামৰ প্ৰথম আয়নীকৰণ শক্তি মৌল X আৰু Y তকৈ তুলনামূলকভাৱে কম কিন্তু Z তকৈ বেছি। মৌল X, Y আৰু Z যথাক্ৰমে, হ'ল :

Options :

86435117383. আৰ্গন, ক্ল'ৰিন আৰু ছডিয়াম

86435117384. ক্ল'ৰিন, লিথিয়াম আৰু ছডিয়াম

86435117385. আৰ্গন, লিথিয়াম আৰু ছডিয়াম

86435117386. নিয়ন, ছডিয়াম আৰু ক্ল'ৰিন

Question Number : 35 Question Id : 8643515795 Question Type : MCQ Option Shuffling : Yes Is Question Mandatory : No

Correct Marks : 4 Wrong Marks : 1

Match List - I with List - II :

List - I	List - II
(a) Mercury	(i) Vapour phase refining
(b) Copper	(ii) Distillation Refining
(c) Silicon	(iii) Electrolytic Refining
(d) Nickel	(iv) Zone Refining

Choose the most appropriate answer from the option given below :

Options :

86435117387. (a)-(ii), (b)-(iii), (c)-(iv), (d)-(i)

86435117388. (a)-(i), (b)-(iv), (c)-(ii), (d)-(iii)

86435117389. (a)-(ii), (b)-(iii), (c)-(i), (d)-(iv)

86435117390. (a)-(ii), (b)-(iv), (c)-(iii), (d)-(i)

Question Number : 35 Question Id : 8643515795 Question Type : MCQ Option Shuffling : Yes Is Question Mandatory : No

Correct Marks : 4 Wrong Marks : 1

তালিকা - I ক তালিকা - II ব সৈতে মিলন কৰা :

তালিকা - I	তালিকা - II
(a) মাৰকিউৰী	(i) বাষ্পীয় প্ৰাৰছা শোধন
(b) ক'পাৰ	(ii) পাতন শোধন
(c) ছিলিকন	(iii) বিদ্যুৎ বিশ্লেষ্য শোধন
(d) নিকেল	(iv) মণ্ডল শোধন

নিম্নলিখিত বিকল্পবপৰা আটাইতকৈ উপযুক্ত উত্তৰ বাছি উলিওৱা :

Options :

86435117387. (a)-(ii), (b)-(iii), (c)-(iv), (d)-(i)

86435117388. (a)-(i), (b)-(iv), (c)-(ii), (d)-(iii)

86435117389. (a)-(ii), (b)-(iii), (c)-(i), (d)-(iv)

86435117390. (a)-(ii), (b)-(iv), (c)-(iii), (d)-(i)

Question Number : 36 Question Id : 8643515796 Question Type : MCQ Option Shuffling : Yes Is Question Mandatory : No

Correct Marks : 4 Wrong Marks : 1

In basic medium, H_2O_2 exhibits which of the following reactions ?

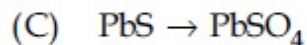
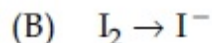
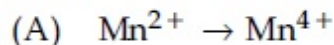

Choose the most appropriate answer from the options given below :

Options :

86435117391. (A) only

86435117392. (B) only

86435117393. (A), (B) only

86435117394. (A), (C) only

Question Number : 36 Question Id : 8643515796 Question Type : MCQ Option Shuffling : Yes Is Question Mandatory : No

Correct Marks : 4 Wrong Marks : 1

ক্ষাৰকীয় মাধ্যমত H_2O_2 এ নিম্নলিখিত কোনটো বিক্ৰিয়া দেখুৱায় :

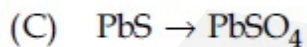
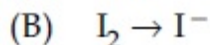
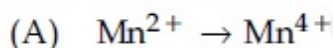

নিম্নলিখিত বিকল্পৰপৰা আটাইতকৈ উপযুক্ত উত্তৰটো বাছি উলিওৱা :

Options :

86435117391. (A) মাত্ৰ

86435117392. (B) মাত্ৰ

86435117393. (A), (B) মাত্ৰ

86435117394. (A), (C) মাত্র

Question Number : 37 Question Id : 8643515797 Question Type : MCQ Option Shuffling : Yes Is Question Mandatory : No

Correct Marks : 4 Wrong Marks : 1

Match List - I with List - II :

List - I	List - II
(a) Be	(i) treatment of cancer
(b) Mg	(ii) extraction of metals
(c) Ca	(iii) incendiary bombs and signals
(d) Ra	(iv) windows of X-ray tubes
	(v) bearings for motor engines.

Choose the most appropriate answer from the option given below :

Options :

86435117395. (a)-(iv), (b)-(iii), (c)-(ii), (d)-(i)

86435117396. (a)-(iii), (b)-(iv), (c)-(ii), (d)-(v)

86435117397. (a)-(iv), (b)-(iii), (c)-(i), (d)-(ii)

86435117398. (a)-(iii), (b)-(iv), (c)-(v), (d)-(ii)

Question Number : 37 Question Id : 8643515797 Question Type : MCQ Option Shuffling : Yes Is Question Mandatory : No

Correct Marks : 4 Wrong Marks : 1

তালিকা - I ক তালিকা - II ৰ সৈতে মিলন কৰা :

তালিকা - I	তালিকা - II
(a) Be	(i) কৰ্কটৰোগৰ চিকিৎসাৰ বাবে
(b) Mg	(ii) ধাতুৰ নিষ্কাশণত
(c) Ca	(iii) প্ৰজ্জ্বালক বোমা আৰু সংকেতত
(d) Ra	(iv) বঞ্জন বশ্মি নলীৰ খিৰিকীত
	(v) মটৰ ইঞ্জিনৰ বিয়েৰিঙত

নিম্নলিখিত বিকল্পৰপৰা আটাইতকৈ উপযুক্ত উত্তৰ বাছি উলিওৱা :

Options :

86435117395. (a)-(iv), (b)-(iii), (c)-(ii), (d)-(i)

86435117396. (a)-(iii), (b)-(iv), (c)-(ii), (d)-(v)

86435117397. (a)-(iv), (b)-(iii), (c)-(i), (d)-(ii)

86435117398. (a)-(iii), (b)-(iv), (c)-(v), (d)-(ii)

Question Number : 38 Question Id : 8643515798 Question Type : MCQ Option Shuffling : Yes Is Question Mandatory : No

Correct Marks : 4 Wrong Marks : 1

The oxidation states of nitrogen in NO, NO₂, N₂O and NO₃⁻ are in the order of :

Options :

86435117399. NO > NO₂ > N₂O > NO₃⁻

86435117400. N₂O > NO₂ > NO > NO₃⁻

86435117401. NO₂ > NO₃⁻ > NO > N₂O

86435117402. NO₃⁻ > NO₂ > NO > N₂O

Question Number : 38 Question Id : 8643515798 Question Type : MCQ Option Shuffling : Yes Is Question Mandatory : No

Correct Marks : 4 Wrong Marks : 1

নাইট্র'জেনৰ NO, NO₂, N₂O আৰু NO₃⁻ ত জাৰণ অৱস্থাৰ ক্ৰম হ'ল :

Options :

86435117399. NO > NO₂ > N₂O > NO₃⁻

86435117400. N₂O > NO₂ > NO > NO₃⁻

86435117401. NO₂ > NO₃⁻ > NO > N₂O

86435117402. NO₃⁻ > NO₂ > NO > N₂O

Question Number : 39 Question Id : 8643515799 Question Type : MCQ Option Shuffling : Yes Is Question Mandatory : No

Correct Marks : 4 Wrong Marks : 1

The oxide that shows magnetic property is :

Options :

86435117403. SiO₂

86435117404. Mn₃O₄

86435117405. MgO

86435117406. Na₂O

Question Number : 39 Question Id : 8643515799 Question Type : MCQ Option Shuffling : Yes Is Question Mandatory : No

Correct Marks : 4 Wrong Marks : 1

অক্সাইড যিয়ে চুম্বকীয় ধৰ্ম দেখুওৱা :

Options :

86435117403. SiO₂

86435117404. Mn₃O₄

86435117405. MgO

86435117406. Na_2O

Question Number : 40 Question Id : 8643515800 Question Type : MCQ Option Shuffling : Yes Is Question Mandatory : No

Correct Marks : 4 Wrong Marks : 1

The secondary valency and the number of hydrogen bonded water molecule(s) in $\text{CuSO}_4 \cdot 5\text{H}_2\text{O}$, respectively, are :

Options :

86435117407. 4 and 1

86435117408. 6 and 4

86435117409. 5 and 1

86435117410. 6 and 5

Question Number : 40 Question Id : 8643515800 Question Type : MCQ Option Shuffling : Yes Is Question Mandatory : No

Correct Marks : 4 Wrong Marks : 1

ছেকেণ্ডাৰী যোজ্যতা আৰু হাইড্ৰ'জেন বান্ধনিযুক্ত পানীৰ অনু(বোৰ)ৰ সংখ্যা $\text{CuSO}_4 \cdot 5\text{H}_2\text{O}$ ত যথাক্ৰমে :

Options :

86435117407. 4 আৰু 1

86435117408. 6 আৰু 4

86435117409. 5 আৰু 1

86435117410. 6 আৰু 5

Question Number : 41 Question Id : 8643515801 Question Type : MCQ Option Shuffling : Yes Is Question Mandatory : No

Correct Marks : 4 Wrong Marks : 1

Given below are two statements :

Statement I : Non-biodegradable wastes are generated by the thermal power plants.

Statement II : Bio-degradable detergents leads to eutrophication.

In the light of the above statements, choose the most appropriate answer from the options given below :

Options :

86435117411. Both statement I and statement II are true.

86435117412. Both statement I and statement II are false.

86435117413. Statement I is true but statement II is false.

86435117414. Statement I is false but statement II is true.

Question Number : 41 Question Id : 8643515801 Question Type : MCQ Option Shuffling : Yes Is

Question Mandatory : No

Correct Marks : 4 Wrong Marks : 1

তলত দুটা উক্তি দিয়া হ'ল :

উক্তি I : তাপীয় শক্তিখণ্ডৰপৰা জৈৱিকভাৱে লীন নোযোৱা আৱৰ্জনাবোৰ উৎপন্ন হয়।

উক্তি II : জীৱক্ৰম ক্ষয়যুক্ত অপমাজৰ্কে অতিপুষ্টি কৰণত অৰিহণা যোগায়।

ওপৰৰ উক্তিৰ আলমত, নিম্নলিখিত বিকল্পৰপৰা আটাইতকৈ উপযুক্ত উত্তৰটো বাছি উলিওৱা :

Options :

86435117411. উক্তি I আৰু উক্তি II দুয়োটা সত্য।

86435117412. উক্তি I আৰু উক্তি II দুয়োটা অসত্য।

86435117413. উক্তি I সত্য কিন্তু উক্তি II অসত্য।

86435117414. উক্তি I অসত্য কিন্তু উক্তি II সত্য।

Question Number : 42 Question Id : 8643515802 Question Type : MCQ Option Shuffling : Yes Is

Question Mandatory : No

Correct Marks : 4 Wrong Marks : 1

Given below are two statements :

Statement I : C_2H_5OH and $AgCN$ both can generate nucleophile.

Statement II : KCN and $AgCN$ both will generate nitrile nucleophile with all reaction conditions.

Choose the most appropriate option :

Options :

86435117415. Both statement I and statement II are true.

86435117416. Both statement I and statement II are false.

86435117417. Statement I is true but statement II is false.

86435117418. Statement I is false but statement II is true.

Question Number : 42 Question Id : 8643515802 Question Type : MCQ Option Shuffling : Yes Is Question Mandatory : No

Correct Marks : 4 Wrong Marks : 1

তলত দুটা উক্তি দিয়া হ'ল :

উক্তি I : C_2H_5OH আৰু $AgCN$ দুয়োএ নিউক্লীয়ফাইল উৎপন্ন কৰিব পাৰে।

উক্তি II : KCN আৰু $AgCN$ দুয়োএ নাইট্ৰাইল নিউক্লীয়ফাইল সকলো বিক্ৰিয়া স্বৰ্ততে উৎপন্ন কৰে।

আটাইতকৈ উপযুক্ত বিকল্প বাছি উলিওৱা :

Options :

86435117415. উক্তি I আৰু উক্তি II দুয়োটা সত্য।

86435117416. উক্তি I আৰু উক্তি II দুয়োটা অসত্য।

86435117417. উক্তি I সত্য কিন্তু উক্তি II অসত্য।

86435117418. উক্তি I অসত্য কিন্তু উক্তি II সত্য।

Question Number : 43 Question Id : 8643515803 Question Type : MCQ Option Shuffling : Yes Is Question Mandatory : No

Correct Marks : 4 Wrong Marks : 1

In the following molecule,

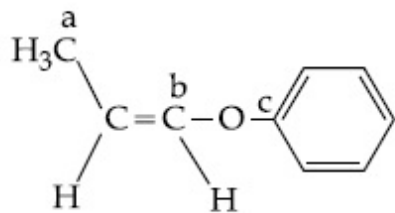

Hybridisation of Carbon a, b and c respectively are :

Options :

86435117419. sp^3, sp^2, sp^2

86435117420. sp^3, sp^2, sp

86435117421. sp^3, sp, sp

86435117422. sp^3, sp, sp^2

Question Number : 43 Question Id : 8643515803 Question Type : MCQ Option Shuffling : Yes Is Question Mandatory : No

Correct Marks : 4 Wrong Marks : 1

নিম্নলিখিত অনুত,

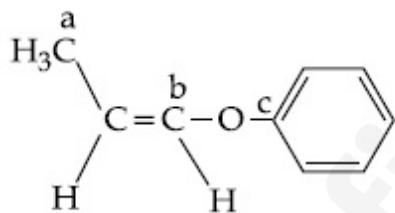

কার্বন a, b আৰু c ৰ সংকৰণ হ'ল যথাক্রমে :

Options :

86435117419. sp^3, sp^2, sp^2

86435117420. sp^3, sp^2, sp

86435117421. sp^3, sp, sp

86435117422. sp^3, sp, sp^2

Question Number : 44 Question Id : 8643515804 Question Type : MCQ Option Shuffling : Yes Is Question Mandatory : No

Correct Marks : 4 Wrong Marks : 1

Main Products formed during a reaction of 1-methoxy naphthalene with hydroiodic acid are :

Options :

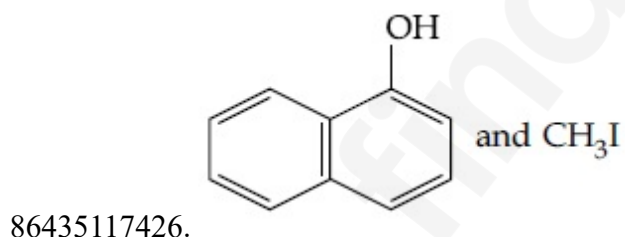
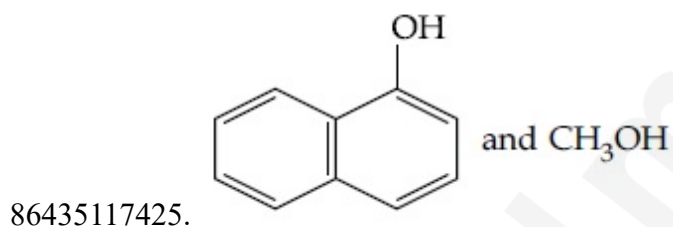
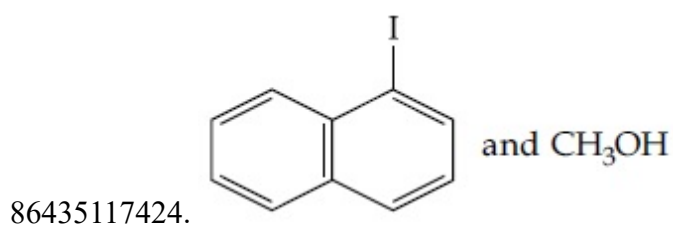
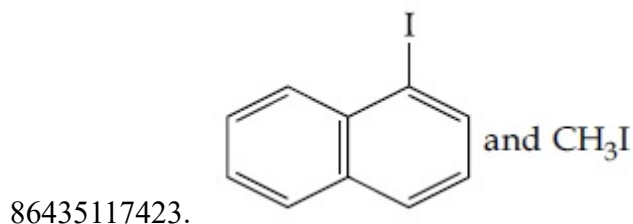

Question Number : 44 Question Id : 8643515804 Question Type : MCQ Option Shuffling : Yes Is Question Mandatory : No

Correct Marks : 4 Wrong Marks : 1

1-মিথক্সি নেফথালিন ৰ হাইড্ৰ আইডিক এছিডৰ লগত বিক্ৰিয়াত উৎপন্ন হোৱা মুখ্য বিক্ৰিয়াজাত পদাৰ্থ হ'ল :

Options :

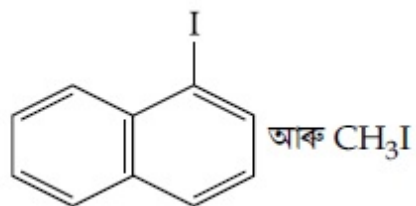

86435117423.

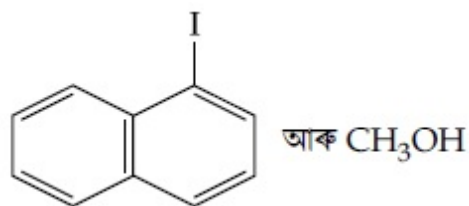

86435117424.

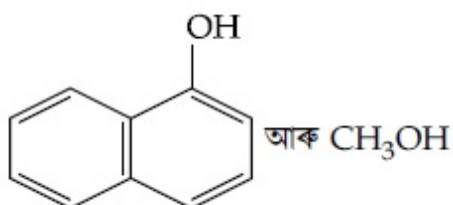

86435117425.

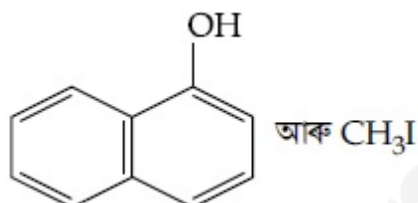

86435117426.

Question Number : 45 Question Id : 8643515805 Question Type : MCQ Option Shuffling : Yes Is

Question Mandatory : No

Correct Marks : 4 Wrong Marks : 1

In the reaction of hypobromite with amide, the carbonyl carbon is lost as :

Options :

86435117427. CO

86435117428. CO_2

86435117429. CO_3^{2-}

86435117430. HCO_3^-

Question Number : 45 Question Id : 8643515805 Question Type : MCQ Option Shuffling : Yes Is

Question Mandatory : No

Correct Marks : 4 Wrong Marks : 1

হাইপ'ব্র'মাইটৰ এমাইডৰ লগত বিক্ৰিয়াত কাৰ্বনিল কাৰ্বন ওলাই যোৱাৰ ৰূপ :

Options :

86435117427. CO

86435117428. CO₂

86435117429. CO₃²⁻

86435117430. HCO₃⁻

Question Number : 46 Question Id : 8643515806 Question Type : MCQ Option Shuffling : Yes Is Question Mandatory : No

Correct Marks : 4 Wrong Marks : 1

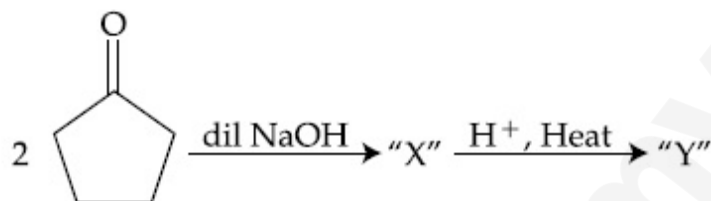

Consider the above reaction, the product 'X' and 'Y' respectively are :

Options :

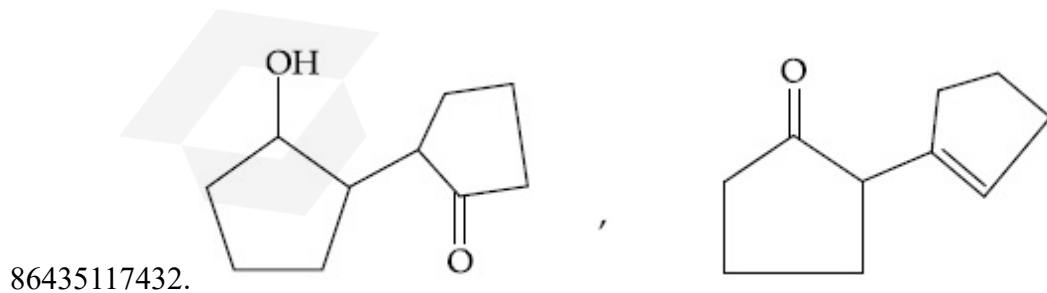
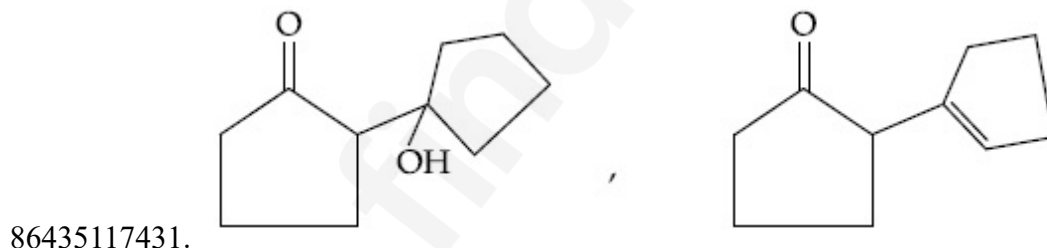

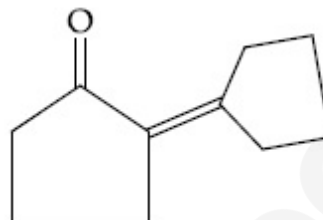
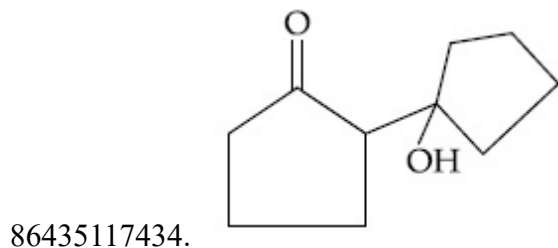
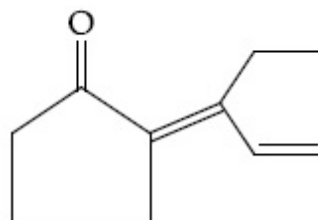
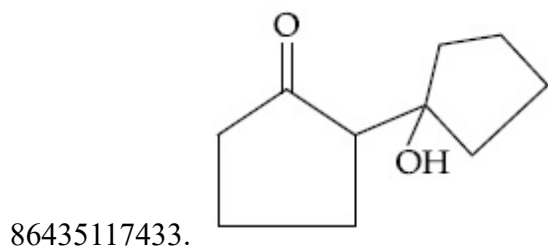

Question Number : 46 Question Id : 8643515806 Question Type : MCQ Option Shuffling : Yes Is Question Mandatory : No

Correct Marks : 4 Wrong Marks : 1

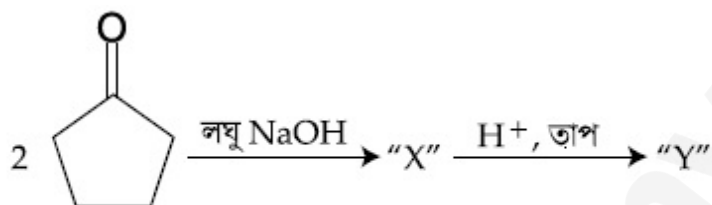

ওপৰৰ বিক্ৰিয়াটো ধৰিলোৱা, জাতদ্বয় 'X' আৰু 'Y' যথাক্ৰমে :

Options :

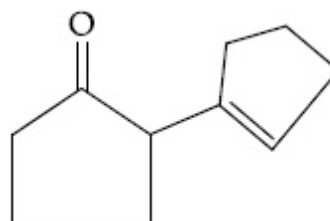
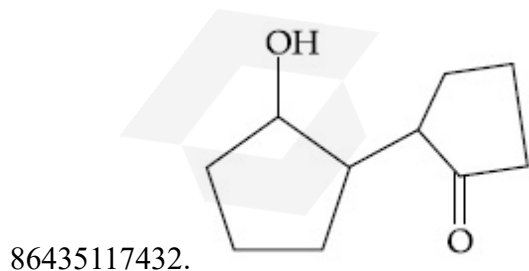
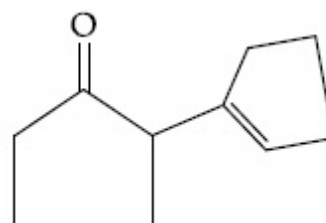
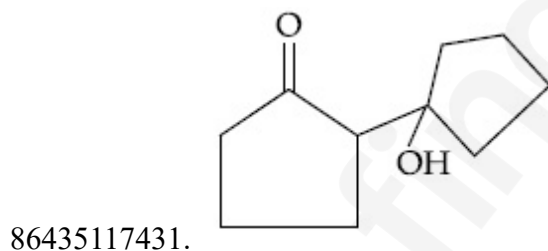

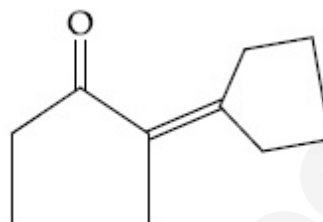
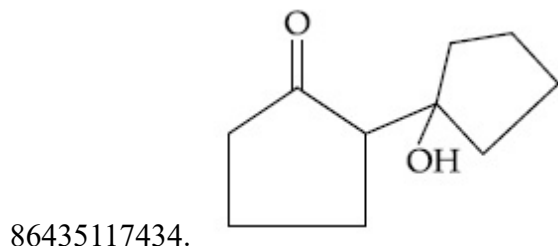
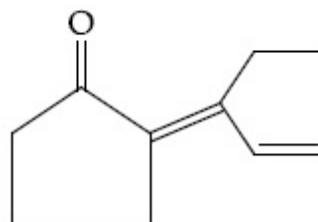
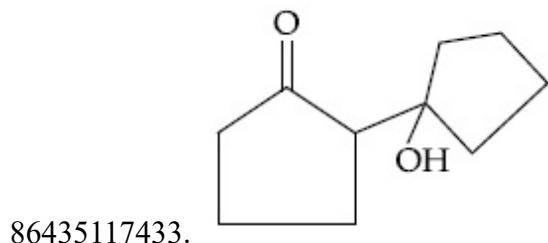

Question Number : 47 Question Id : 8643515807 Question Type : MCQ Option Shuffling : Yes Is Question Mandatory : No

Correct Marks : 4 Wrong Marks : 1

An organic compound "A" on treatment with benzene sulphonyl chloride gives compound B. B is soluble in dil. NaOH solution. Compound A is :

Options :

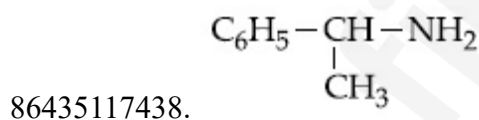
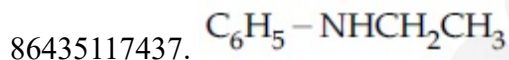
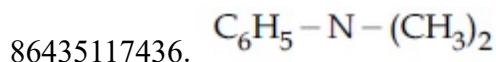
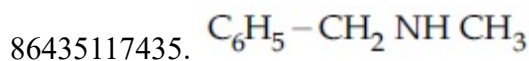

Question Number : 47 Question Id : 8643515807 Question Type : MCQ Option Shuffling : Yes Is Question Mandatory : No

Correct Marks : 4 Wrong Marks : 1

এটা জৈব যৌগ "A" ৰ বেনজিন ছালফ'নিল ক্লৰাইডৰ লগত বিক্রিয়া কৰিলে যৌগ B দিয়ে। B লঘু NaOH দ্ৰৱত দ্ৰৱীভূত হয়। জৈব যৌগ A হ'ল :

Options :

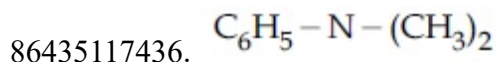
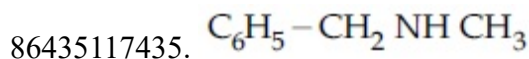

86435117437. $C_6H_5 - NHCH_2CH_3$

86435117438. $C_6H_5 - \underset{\begin{array}{c} | \\ CH_3 \end{array}}{CH} - NH_2$

Question Number : 48 Question Id : 8643515808 Question Type : MCQ Option Shuffling : Yes Is Question Mandatory : No

Correct Marks : 4 Wrong Marks : 1

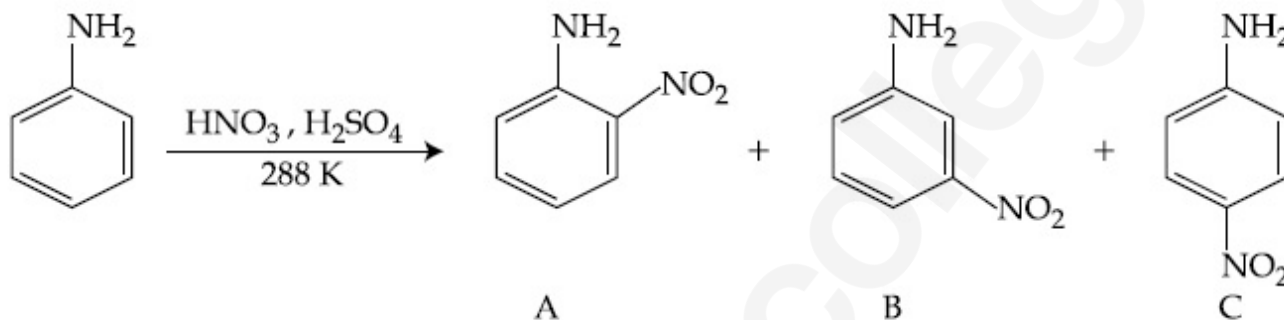

Consider the given reaction, percentage yield of :

Options :

86435117439. $A > C > B$

86435117440. $C > A > B$

86435117441. $B > C > A$

86435117442. $C > B > A$

Question Number : 48 Question Id : 8643515808 Question Type : MCQ Option Shuffling : Yes Is Question Mandatory : No

Correct Marks : 4 Wrong Marks : 1

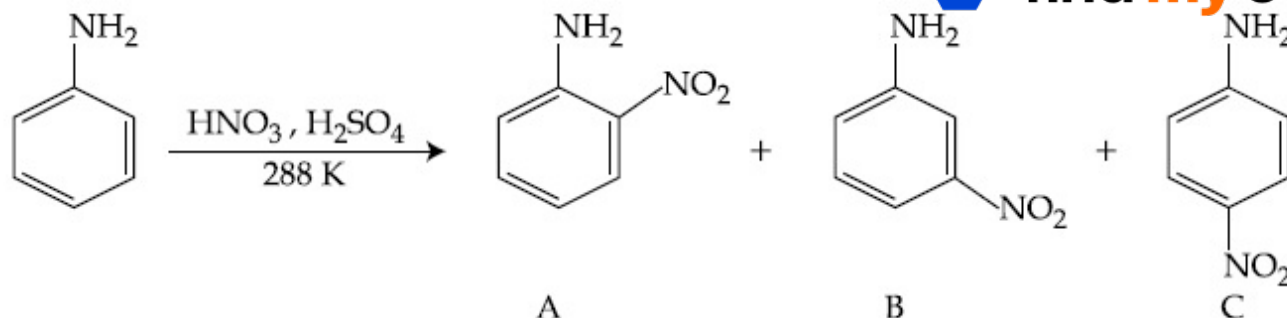

ওপৰৰ বিক্ৰিয়াটো ধৰা, শতকৰা উৎপাদন :

Options :

86435117439. A > C > B

86435117440. C > A > B

86435117441. B > C > A

86435117442. C > B > A

Question Number : 49 Question Id : 8643515809 Question Type : MCQ Option Shuffling : Yes Is Question Mandatory : No

Correct Marks : 4 Wrong Marks : 1

Match List - I with List - II :

List - I (Class of Chemicals)	List - II (Example)
(a) Antifertility drug	(i) Meprobamate
(b) Antibiotic	(ii) Alitame
(c) Tranquilizer	(iii) Norethindrone
(d) Artificial Sweetener	(iv) Salvarsan

Choose the most appropriate match :

Options :

86435117443. (a)-(iv), (b)-(iii), (c)-(ii), (d)-(i)

86435117444. (a)-(ii), (b)-(iii), (c)-(iv), (d)-(i)

86435117445. (a)-(iii), (b)-(iv), (c)-(i), (d)-(ii)

86435117446. (a)-(ii), (b)-(iv), (c)-(i), (d)-(iii)

Question Number : 49 Question Id : 8643515809 Question Type : MCQ Option Shuffling : Yes Is Question Mandatory : No

Correct Marks : 4 Wrong Marks : 1

তালিকা - I ক তালিকা - II ৰ সৈতে মিলন কৰা :

তালিকা - I (ৰসায়নিক দ্ৰব্যৰ শ্ৰেণী)	তালিকা - II (উদাহৰণ)
(a) প্রজননতাবোধী ঔষধ	(i) মেপ্'বেমেট
(b) প্রতিজৈৱিক	(ii) এলিটেম
(c) সুস্থিৰকাৰী	(iii) নৰেথিনড্ৰ'ন
(d) কৃত্ৰিম মিঠাকৰী	(iv) ছেলভেৰছন

আটাইতকৈ উপযুক্ত মিলনটো বাছি উলিওৱা :

Options :

86435117443. (a)-(iv), (b)-(iii), (c)-(ii), (d)-(i)

86435117444. (a)-(ii), (b)-(iii), (c)-(iv), (d)-(i)

86435117445. (a)-(iii), (b)-(iv), (c)-(i), (d)-(ii)

86435117446. (a)-(ii), (b)-(iv), (c)-(i), (d)-(iii)

Question Number : 50 Question Id : 8643515810 Question Type : MCQ Option Shuffling : Yes Is Question Mandatory : No

Correct Marks : 4 Wrong Marks : 1

Deficiency of vitamin K causes :

Options :

86435117447. Increase in blood clotting time

86435117448. Decrease in blood clotting time

86435117449. Cheilosis

86435117450. Increase in fragility of RBC's

Question Number : 50 Question Id : 8643515810 Question Type : MCQ Option Shuffling : Yes Is

Question Mandatory : No

Correct Marks : 4 Wrong Marks : 1

ভিটামিন K ৰ অভাৱে কৰে :

Options :

86435117447. তেজৰ চেকুৰা বন্ধা সময় বঢ়ায়

86435117448. তেজৰ চেকুৰা বন্ধা সময় কমায়

86435117449. ছেইল'ছিছ

86435117450. RBC ৰ ভঙ্গুৰতা বঢ়ায়

Chemistry Section B

Section Id :	864351388
Section Number :	4
Section type :	Online
Mandatory or Optional :	Mandatory
Number of Questions :	10
Number of Questions to be attempted :	5
Section Marks :	20
Mark As Answered Required? :	Yes
Sub-Section Number :	1
Sub-Section Id :	864351388
Question Shuffling Allowed :	Yes

Question Number : 51 Question Id : 8643515811 Question Type : SA

Correct Marks : 4 Wrong Marks : 0

10.0 mL of Na_2CO_3 solution is titrated against 0.2 M HCl solution. The following titre values were obtained in 5 readings :

4.8 mL, 4.9 mL, 5.0 mL, 5.0 mL and 5.0 mL.

Based on these readings, and convention of titrimetric estimation the concentration of Na_2CO_3 solution is _____ mM.

(Round off to the Nearest Integer).

Response Type : Numeric**Evaluation Required For SA :** Yes**Show Word Count :** Yes**Answers Type :** Equal**Text Areas :** PlainText**Possible Answers :**

100

Question Number : 51 **Question Id :** 8643515811 **Question Type :** SA**Correct Marks :** 4 **Wrong Marks :** 0

10.0 mL Na_2CO_3 দ্রৱৰ 0.2 M HCl দ্রৱৰ বিপৰীতে অনুমাপন কৰা হ'ল। নিম্নলিখিত মান (titre values) পোৱা গ'ল 5 টা অধ্যয়নৰ :

4.8 mL, 4.9 mL, 5.0 mL, 5.0 mL আৰু 5.0 mL.

ওপৰৰ অধ্যয়নৰ ভেটিত, আৰু টাইট্ৰিমेट্ৰিক আকলনৰ পৰম্পৰা অনুসৰি Na_2CO_3 দ্রৱৰ গাঢ়তা হ'ল _____ mM ।

(নিকটতম অখণ্ড সংখ্যাত)।

Response Type : Numeric**Evaluation Required For SA :** Yes**Show Word Count :** Yes**Answers Type :** Equal**Text Areas :** PlainText**Possible Answers :**

100

Question Number : 52 **Question Id :** 8643515812 **Question Type :** SA**Correct Marks :** 4 **Wrong Marks :** 0

The number of species below that have two lone pairs of electrons in their central atom is _____. (Round off to the Nearest Integer).

SF_4 , BF_4^- , ClF_3 , AsF_3 , PCl_5 , BrF_5 , XeF_4 , SF_6

Response Type : Numeric**Evaluation Required For SA :** Yes**Show Word Count :** Yes**Answers Type :** Equal**Text Areas :** PlainText**Possible Answers :**

100

Question Number : 52 **Question Id :** 8643515812 **Question Type :** SA

Correct Marks : 4 Wrong Marks : 0

কেন্দ্রীয় পৰমাণুত দুটা একাকী যুগ্ম ইলেক্ট্ৰন থকা অনুৰ সংখ্যা নিম্নলিখিতৰ পৰা _____। (নিকটতম অখণ্ড সংখ্যাত)।

SF_4 , BF_4^- , ClF_3 , AsF_3 , PCl_5 , BrF_5 , XeF_4 , SF_6

Response Type : Numeric

Evaluation Required For SA : Yes

Show Word Count : Yes

Answers Type : Equal

Text Areas : PlainText

Possible Answers :

100

Question Number : 53 Question Id : 8643515813 Question Type : SA

Correct Marks : 4 Wrong Marks : 0

The gas phase reaction

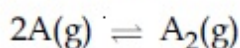

at 400 K has $\Delta G^\circ = +25.2 \text{ kJ mol}^{-1}$.

The equilibrium constant K_C for this reaction is _____ $\times 10^{-2}$. (Round off to the Nearest Integer).

[Use : $R = 8.3 \text{ J mol}^{-1} \text{ K}^{-1}$, $\ln 10 = 2.3$

$\log_{10} 2 = 0.30$, $1 \text{ atm} = 1 \text{ bar}$]

[antilog $(-0.3) = 0.501$]

Response Type : Numeric

Evaluation Required For SA : Yes

Show Word Count : Yes

Answers Type : Equal

Text Areas : PlainText

Possible Answers :

100

Question Number : 53 Question Id : 8643515813 Question Type : SA

Correct Marks : 4 Wrong Marks : 0

গেছীয় দশা বিক্রিয়া

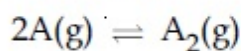

400 K ত $\Delta G^\circ = +25.2 \text{ kJ mol}^{-1}$ ।

বিক্রিয়াটোৰ বাবে সাম্য ধ্রুবক K_C ৰ মান _____ $\times 10^{-2}$ । (নিকটতম অখণ্ড সংখ্যাত)।

[ব্যৱহাৰ কৰা : $R = 8.3 \text{ J mol}^{-1} \text{ K}^{-1}$, $\ln 10 = 2.3$

$\log_{10} 2 = 0.30$, $1 \text{ atm} = 1 \text{ bar}$]

[antilog (-0.3) = 0.501]

Response Type : Numeric

Evaluation Required For SA : Yes

Show Word Count : Yes

Answers Type : Equal

Text Areas : PlainText

Possible Answers :

100

Question Number : 54 **Question Id :** 8643515814 **Question Type :** SA

Correct Marks : 4 **Wrong Marks :** 0

A solute A dimerizes in water. The boiling point of a 2 molal solution of A is 100.52°C . The percentage association of A is _____. (Round off to the Nearest Integer).

[Use : K_b for water = $0.52 \text{ K kg mol}^{-1}$

Boiling point of water = 100°C]

Response Type : Numeric

Evaluation Required For SA : Yes

Show Word Count : Yes

Answers Type : Equal

Text Areas : PlainText

Possible Answers :

100

Question Number : 54 **Question Id :** 8643515814 **Question Type :** SA

Correct Marks : 4 **Wrong Marks :** 0

এটা দ্ৰৱ A পানীত দ্ব্যণুকীকৰণ (dimerize) হয়। A ৰ 2 ম'লাল দ্ৰৱ এটাৰ উতলাংক 100.52°C । শতকৰা সংযুতি

A ৰ _____। (নিকটতম অখণ্ড সংখ্যাত)।

[ব্যৱহাৰ কৰা : পানীৰ বাবে $K_b = 0.52 \text{ K kg mol}^{-1}$

পানীৰ উতলাংক = 100°C]

Response Type : Numeric

Evaluation Required For SA : Yes

Show Word Count : Yes

Answers Type : Equal

Text Areas : PlainText

Possible Answers :

100

Question Number : 55 Question Id : 8643515815 Question Type : SA

Correct Marks : 4 Wrong Marks : 0

The solubility of CdSO_4 in water is $8.0 \times 10^{-4} \text{ mol L}^{-1}$. Its solubility in $0.01 \text{ M H}_2\text{SO}_4$ solution is _____ $\times 10^{-6} \text{ mol L}^{-1}$. (Round off to the Nearest Integer).

(Assume that solubility is much less than 0.01 M)

Response Type : Numeric

Evaluation Required For SA : Yes

Show Word Count : Yes

Answers Type : Equal

Text Areas : PlainText

Possible Answers :

100

Question Number : 55 Question Id : 8643515815 Question Type : SA

Correct Marks : 4 Wrong Marks : 0

পানীত CdSO_4 ৰ দ্রৱণীয়তা $8.0 \times 10^{-4} \text{ mol L}^{-1}$ । ইয়াৰ $0.01 \text{ M H}_2\text{SO}_4$ দ্রৱত দ্রৱণীয়তা হ'ল _____ $\times 10^{-6} \text{ mol L}^{-1}$ । (নিকটতম অখণ্ড সংখ্যাত)।

(ধৰিলোৱা যে দ্রৱণীয়তা 0.01 M তকৈ বহুত কম)

Response Type : Numeric

Evaluation Required For SA : Yes

Show Word Count : Yes

Answers Type : Equal

Text Areas : PlainText

Possible Answers :

100

Question Number : 56 Question Id : 8643515816 Question Type : SA

Correct Marks : 4 Wrong Marks : 0

The molar conductivities at infinite dilution of barium chloride, sulphuric acid and hydrochloric acid are $280, 860$ and $426 \text{ S cm}^2 \text{ mol}^{-1}$ respectively. The molar conductivity at infinite dilution of barium sulphate is _____ $\text{ S cm}^2 \text{ mol}^{-1}$. (Round off to the Nearest Integer).

Response Type : Numeric

Evaluation Required For SA : Yes

Show Word Count : Yes

Answers Type : Equal

Text Areas : PlainText

Possible Answers :

100

Question Number : 56 Question Id : 8643515816 Question Type : SA

Correct Marks : 4 Wrong Marks : 0

অসীম লঘুতাত, ম'লাৰ পৰিবাহিতা বেৰিয়াম ক্ল'ৰাইড, ছালফিউৰিক এছিড আৰু হাইড্ৰক্ল'ৰিক এছিডৰ 280, 860 আৰু 426 S cm² mol⁻¹ যথাক্ৰমে। বেৰিয়াম ছালফেটৰ, অসীম লঘুতাত ম'লাৰ পৰিবাহিতা হ'ল _____ S cm² mol⁻¹। (নিকটতম অখণ্ড সংখ্যাত)।

Response Type : Numeric

Evaluation Required For SA : Yes

Show Word Count : Yes

Answers Type : Equal

Text Areas : PlainText

Possible Answers :

100

Question Number : 57 Question Id : 8643515817 Question Type : SA

Correct Marks : 4 Wrong Marks : 0

A reaction has a half life of 1 min. The time required for 99.9% completion of the reaction is _____ min. (Round off to the Nearest Integer).

[Use : ln 2 = 0.69; ln 10 = 2.3]

Response Type : Numeric

Evaluation Required For SA : Yes

Show Word Count : Yes

Answers Type : Equal

Text Areas : PlainText

Possible Answers :

100

Question Number : 57 Question Id : 8643515817 Question Type : SA

Correct Marks : 4 Wrong Marks : 0

এটা বিক্রিয়াৰ অৰ্ধজীৱনকাল 1 min। বিক্রিয়াটোৰ 99.9% সম্পূৰ্ণ হওঁতে লগা সময় _____ min। (নিকটতম অখণ্ড সংখ্যাত)।

[ব্যৱহাৰ কৰা : ln 2 = 0.69; ln 10 = 2.3]

Response Type : Numeric

Evaluation Required For SA : Yes

Show Word Count : Yes

Answers Type : Equal

Text Areas : PlainText

Possible Answers :

100

Question Number : 58 Question Id : 8643515818 Question Type : SA

Correct Marks : 4 Wrong Marks : 0

A xenon compound 'A' upon partial hydrolysis gives XeO_2F_2 . The number of lone pair of electrons present in compound A is _____. (Round off to the Nearest Integer)

Response Type : Numeric

Evaluation Required For SA : Yes

Show Word Count : Yes

Answers Type : Equal

Text Areas : PlainText

Possible Answers :

100

Question Number : 58 Question Id : 8643515818 Question Type : SA

Correct Marks : 4 Wrong Marks : 0

এটা জেননৰ যৌগ 'A' এ আংশিক জল অপঘটন বিক্ৰিয়াত দিয়ে XeO_2F_2 । যৌগ A ত থকা একাকী যুগ্ম ইলেক্ট্ৰনৰ সংখ্যা _____। (নিকটতম অখণ্ড সংখ্যা)

Response Type : Numeric

Evaluation Required For SA : Yes

Show Word Count : Yes

Answers Type : Equal

Text Areas : PlainText

Possible Answers :

100

Question Number : 59 Question Id : 8643515819 Question Type : SA

Correct Marks : 4 Wrong Marks : 0

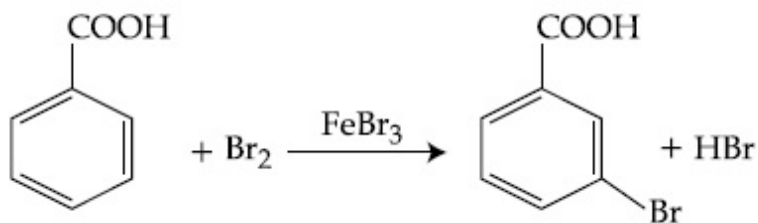

Consider the above reaction where 6.1 g of Benzoic acid is used to get 7.8 g of m-bromo benzoic acid. The percentage yield of the product is _____.

(Round off to the Nearest Integer).

[Given : Atomic masses : C : 12.0 u, H : 1.0 u, O : 16.0 u, Br : 80.0 u]

Response Type : Numeric

Evaluation Required For SA : Yes

Show Word Count : Yes

Answers Type : Equal

Text Areas : PlainText

Possible Answers :

100

Question Number : 59 **Question Id :** 8643515819 **Question Type :** SA

Correct Marks : 4 **Wrong Marks :** 0

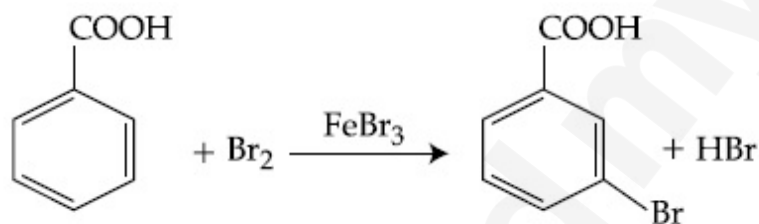

ওপৰৰ বিক্ৰিয়াটো লোৱা, য'ত 6.1 g বেনযয়িক এছিড 7.8 g m-ব্ৰ'ম'বেনযয়িক এছিড প্ৰাপ্তিৰ বাবে ব্যৱহাৰ কৰা হয়।

বিক্ৰিয়াজাত পদাৰ্থটোৰ শতকৰা উৎপাদন হ'ল _____.

(নিকটতম অখণ্ড সংখ্যাত)।

[দিয়া আছে : পাৰমাণৱিক ভৰ : C : 12.0 u, H : 1.0 u, O : 16.0 u, Br : 80.0 u]

Response Type : Numeric

Evaluation Required For SA : Yes

Show Word Count : Yes

Answers Type : Equal

Text Areas : PlainText

Possible Answers :

100

Question Number : 60 **Question Id :** 8643515820 **Question Type :** SA

Correct Marks : 4 Wrong Marks : 0

In Tollen's test for aldehyde, the overall number of electron(s) transferred to the Tollen's reagent formula $[\text{Ag}(\text{NH}_3)_2]^+$ per aldehyde group to form silver mirror is _____.
(Round off to the Nearest Integer).

Response Type : Numeric

Evaluation Required For SA : Yes

Show Word Count : Yes

Answers Type : Equal

Text Areas : PlainText

Possible Answers :

100

Question Number : 60 Question Id : 8643515820 Question Type : SA

Correct Marks : 4 Wrong Marks : 0

এলডিহাইডৰ বাবে কৰা টলেম্বৰ পৰীক্ষাত, ছিলভাৰ দাপোণ গঠিত হ'বৰ কাৰণে, এলডিহাইড গ্ৰুপে প্ৰতি টলেম্ব বিকাৰক
(সূত্র $[\text{Ag}(\text{NH}_3)_2]^+$) লৈ ছানান্তৰিত হোৱা ইলেক্ট্ৰনৰ মুঠ সংখ্যা _____। (নিকটতম অখণ্ড সংখ্যাত)।

Response Type : Numeric

Evaluation Required For SA : Yes

Show Word Count : Yes

Answers Type : Equal

Text Areas : PlainText

Possible Answers :

100

Mathematics Section A

Section Id :	864351389
Section Number :	5
Section type :	Online
Mandatory or Optional :	Mandatory
Number of Questions :	20
Number of Questions to be attempted :	20
Section Marks :	80
Mark As Answered Required? :	Yes
Sub-Section Number :	1
Sub-Section Id :	864351389
Question Shuffling Allowed :	Yes

Question Number : 61 Question Id : 8643515821 Question Type : MCQ Option Shuffling : Yes Is

Question Mandatory : No

Correct Marks : 4 Wrong Marks : 1

If $15\sin^4\alpha + 10\cos^4\alpha = 6$, for some $\alpha \in \mathbb{R}$, then the value of $27\sec^6\alpha + 8\operatorname{cosec}^6\alpha$ is equal to :

Options :

86435117461. 500

86435117462. 400

86435117463. 350

86435117464. 250

Question Number : 61 Question Id : 8643515821 Question Type : MCQ Option Shuffling : Yes Is Question Mandatory : No

Correct Marks : 4 Wrong Marks : 1

কিছুমান $\alpha \in \mathbb{R}$ ৰ বাবে যদি $15\sin^4\alpha + 10\cos^4\alpha = 6$, তেন্তে $27\sec^6\alpha + 8\operatorname{cosec}^6\alpha$ ৰ মান সমান হ'ব :

Options :

86435117461. 500

86435117462. 400

86435117463. 350

86435117464. 250

Question Number : 62 Question Id : 8643515822 Question Type : MCQ Option Shuffling : Yes Is Question Mandatory : No

Correct Marks : 4 Wrong Marks : 1

If P and Q are two statements, then which of the following compound statement is a tautology ?

Options :

86435117465. $((P \Rightarrow Q) \wedge \sim Q) \Rightarrow P$

86435117466. $((P \Rightarrow Q) \wedge \sim Q) \Rightarrow Q$

86435117467. $((P \Rightarrow Q) \wedge \sim Q) \Rightarrow \sim P$

86435117468. $((P \Rightarrow Q) \wedge \sim Q) \Rightarrow (P \wedge Q)$

Question Number : 62 Question Id : 8643515822 Question Type : MCQ Option Shuffling : Yes Is Question Mandatory : No

Correct Marks : 4 Wrong Marks : 1

যদি P আৰু Q দুটা উক্তি, তেন্তে কোনটো যৌগিক উক্তি এটা পুনৰুক্তি হ'ব ?

Options :

86435117465. $((P \Rightarrow Q) \wedge \sim Q) \Rightarrow P$

86435117466. $((P \Rightarrow Q) \wedge \sim Q) \Rightarrow Q$

86435117467. $((P \Rightarrow Q) \wedge \sim Q) \Rightarrow \sim P$

86435117468. $((P \Rightarrow Q) \wedge \sim Q) \Rightarrow (P \wedge Q)$

Question Number : 63 Question Id : 8643515823 Question Type : MCQ Option Shuffling : Yes Is Question Mandatory : No

Correct Marks : 4 Wrong Marks : 1

A pole stands vertically inside a triangular park ABC. Let the angle of elevation of the top of the pole from each corner of the park be $\frac{\pi}{3}$. If the radius of the circumcircle of ΔABC is 2, then the height of the pole is equal to :

Options :

86435117469. $\frac{2\sqrt{3}}{3}$

86435117470. $2\sqrt{3}$

86435117471. $\frac{1}{\sqrt{3}}$

86435117472. $\sqrt{3}$

Question Number : 63 Question Id : 8643515823 Question Type : MCQ Option Shuffling : Yes Is Question Mandatory : No

Correct Marks : 4 Wrong Marks : 1

ABC ত্ৰিভুজ আকৃতিৰ উদ্যানৰ ভিতৰত এটা স্তম্ভ উলম্ব ভাবে আছে। ধৰা হ'ল উদ্যানটোৰ প্ৰতিটো কোণৰ পৰা স্তম্ভটোৰ

শীৰ্ষৰ উঠনকোণ $\frac{\pi}{3}$ । যদি ΔABC ৰ পৰিকেন্দ্ৰৰ ব্যাসার্ধ 2, তেন্তে স্তম্ভটোৰ উচ্চতা সমান হ'ব :

Options :

86435117469. $\frac{2\sqrt{3}}{3}$

86435117470. $2\sqrt{3}$

86435117471. $\frac{1}{\sqrt{3}}$

86435117472. $\sqrt{3}$

Question Number : 64 Question Id : 8643515824 Question Type : MCQ Option Shuffling : Yes Is

Question Mandatory : No

Correct Marks : 4 Wrong Marks : 1

Let in a series of $2n$ observations, half of them are equal to a and remaining half are equal to $-a$. Also by adding a constant b in each of these observations, the mean and standard deviation of new set become 5 and 20, respectively. Then the value of $a^2 + b^2$ is equal to :

Options :

86435117473. 925

86435117474. 425

86435117475. 650

86435117476. 250

Question Number : 64 Question Id : 8643515824 Question Type : MCQ Option Shuffling : Yes Is

Question Mandatory : No

Correct Marks : 4 Wrong Marks : 1

ধৰা হ'ল $2n$ পৰ্য্যবেক্ষণৰ শ্ৰেণী এটাত আধাখিনি a ৰ সমান আৰু অৱশিষ্ট আধাখিনি $-a$ ৰ সমান। প্ৰতিটো পৰ্য্যবেক্ষণৰ লগত এটা ধ্ৰুবক b যোগ কৰাত নতুন পৰ্য্যবেক্ষণটোৰ মাধ্য আৰু প্ৰামাণিক বিচ্যুতি 5 আৰু 20 পোৱা গ'ল। তেন্তে $a^2 + b^2$ ৰ মান সমান হ'ব :

Options :

86435117473. 925

86435117474. 425

86435117475. 650

86435117476. 250

Question Number : 65 Question Id : 8643515825 Question Type : MCQ Option Shuffling : Yes Is

Question Mandatory : No

Correct Marks : 4 Wrong Marks : 1

Let in a Binomial distribution, consisting of 5 independent trials, probabilities of exactly 1 and 2 successes be 0.4096 and 0.2048 respectively. Then the probability of getting exactly 3 successes is equal to :

Options :

86435117477. $\frac{40}{243}$

86435117478. $\frac{80}{243}$

86435117479. $\frac{128}{625}$

86435117480. $\frac{32}{625}$

Question Number : 65 Question Id : 8643515825 Question Type : MCQ Option Shuffling : Yes Is

Question Mandatory : No

Correct Marks : 4 Wrong Marks : 1

ধৰা হ'ল এটা দ্বিপদ বন্টন 5 টা স্বতন্ত্ৰ প্ৰচেষ্টাৰে গঠিত, কেবল 1 আৰু 2 ৰ কৃতকাৰ্য্যৰ সম্ভাৱিতা ক্ৰমে 0.4096 আৰু 0.2048 । তেন্তে কেৱল 3 কৃতকাৰ্য্যৰ প্ৰাপ্ত ৰ সম্ভাৱিতা সমান হ'ব :

Options :

86435117477. $\frac{40}{243}$

$$86435117478. \quad \frac{80}{243}$$

$$86435117479. \quad \frac{128}{625}$$

$$86435117480. \quad \frac{32}{625}$$

Question Number : 66 Question Id : 8643515826 Question Type : MCQ Option Shuffling : Yes Is Question Mandatory : No

Correct Marks : 4 Wrong Marks : 1

In a triangle ABC, if $|\vec{BC}| = 8$, $|\vec{CA}| = 7$, $|\vec{AB}| = 10$, then the projection of the vector \vec{AB} on \vec{AC} is equal to :

Options :

$$86435117481. \quad \frac{115}{16}$$

$$86435117482. \quad \frac{85}{14}$$

$$86435117483. \quad \frac{127}{20}$$

$$86435117484. \quad \frac{25}{4}$$

Question Number : 66 Question Id : 8643515826 Question Type : MCQ Option Shuffling : Yes Is Question Mandatory : No

Correct Marks : 4 Wrong Marks : 1

ABC ত্রিভুজত $|\vec{BC}| = 8$, $|\vec{CA}| = 7$, $|\vec{AB}| = 10$ তেন্তে \vec{AB} ভেক্টৰৰ \vec{AC} ৰ অভিক্ষেপ সমান হ'ব :

Options :

$$86435117481. \quad \frac{115}{16}$$

$$86435117482. \quad \frac{85}{14}$$

$$86435117483. \quad \frac{127}{20}$$

$$86435117484. \quad \frac{25}{4}$$

Question Number : 67 Question Id : 8643515827 Question Type : MCQ Option Shuffling : Yes Is Question Mandatory : No

Correct Marks : 4 Wrong Marks : 1

Let the centroid of an equilateral triangle ABC be at the origin. Let one of the sides of the equilateral triangle be along the straight line $x + y = 3$. If R and r be the radius of circumcircle and incircle respectively of ΔABC , then $(R + r)$ is equal to :

Options :

$$86435117485. \quad 2\sqrt{2}$$

$$86435117486. \quad \frac{9}{\sqrt{2}}$$

$$86435117487. \quad 7\sqrt{2}$$

$$86435117488. \quad 3\sqrt{2}$$

Question Number : 67 Question Id : 8643515827 Question Type : MCQ Option Shuffling : Yes Is Question Mandatory : No

Correct Marks : 4 Wrong Marks : 1

ধৰা হ'ল ABC ত্ৰিভুজৰ ভৰকেন্দ্ৰটো মূলবিন্দুতে আছে। ধৰা হ'ল সমবাহু ত্ৰিভুজৰ যিকোনো এটা বাহু $x + y = 3$ । যদি ΔABC ৰ পৰিকেন্দ্ৰ আৰু অন্তকেন্দ্ৰৰ ব্যাসার্ধ ক্ৰমে R আৰু r হয়, তেন্তে $(R + r)$ সমান হ'ব :

Options :

$$86435117485. \quad 2\sqrt{2}$$

86435117486. $\frac{9}{\sqrt{2}}$

86435117487. $7\sqrt{2}$

86435117488. $3\sqrt{2}$

Question Number : 68 Question Id : 8643515828 Question Type : MCQ Option Shuffling : Yes Is Question Mandatory : No Correct Marks : 4 Wrong Marks : 1

Let a tangent be drawn to the ellipse $\frac{x^2}{27} + y^2 = 1$ at $(3\sqrt{3}\cos\theta, \sin\theta)$ where $\theta \in \left(0, \frac{\pi}{2}\right)$.

Then the value of θ such that the sum of intercepts on axes made by this tangent is minimum is equal to :

Options :

86435117489. $\frac{\pi}{3}$

86435117490. $\frac{\pi}{6}$

86435117491. $\frac{\pi}{8}$

86435117492. $\frac{\pi}{4}$

Question Number : 68 Question Id : 8643515828 Question Type : MCQ Option Shuffling : Yes Is Question Mandatory : No Correct Marks : 4 Wrong Marks : 1

ধৰা হ'ল $\frac{x^2}{27} + y^2 = 1$ উপবৃত্তৰ $(3\sqrt{3}\cos\theta, \sin\theta)$, যত $\theta \in \left(0, \frac{\pi}{2}\right)$ বিন্দুত এডাল স্পৰ্শক টনা হ'ল। তেন্তে স্পৰ্শকডালে অক্ষদ্বয়ৰ সৈতে উৎপন্ন কৰা ছেদাংশৰ যোগফল সৰ্বনিম্ন হোৱাকৈ θ ৰ মান সমান হ'ব :

Options :

86435117489. $\frac{\pi}{3}$

86435117490. $\frac{\pi}{6}$

86435117491. $\frac{\pi}{8}$

86435117492. $\frac{\pi}{4}$

Question Number : 69 Question Id : 8643515829 Question Type : MCQ Option Shuffling : Yes Is Question Mandatory : No Correct Marks : 4 Wrong Marks : 1

Let $y = y(x)$ be the solution of the differential equation $\frac{dy}{dx} = (y + 1) \left((y + 1)e^{x^{3/2} - x} \right)$,

$0 < x < 2.1$, with $y(2) = 0$. Then the value of $\frac{dy}{dx}$ at $x = 1$ is equal to :

Options :

86435117493. $\frac{e^{5/2}}{(1 + e^2)^2}$

86435117494. $-\frac{2e^2}{(1 + e^2)^2}$

86435117495. $\frac{5e^{1/2}}{(e^2 + 1)^2}$

86435117496. $\frac{-e^{3/2}}{(e^2 + 1)^2}$

Question Number : 69 Question Id : 8643515829 Question Type : MCQ Option Shuffling : Yes Is

Question Mandatory : No

Correct Marks : 4 Wrong Marks : 1

$\frac{dy}{dx} = (y + 1) \left((y + 1)e^{x^{2/2}} - x \right)$, অৱকলন সমীকৰণৰ সমাধান $y = y(x)$ বুলি ধৰা হ'ল। $0 < x < 2.1, y(2) = 0$

তেতিয়া $x=1$ ত $\frac{dy}{dx}$ ৰ মান সমান হ'ব :

Options :

86435117493. $\frac{e^{5/2}}{(1 + e^2)^2}$

86435117494. $-\frac{2e^2}{(1 + e^2)^2}$

86435117495. $\frac{5e^{1/2}}{(e^2 + 1)^2}$

86435117496. $\frac{-e^{3/2}}{(e^2 + 1)^2}$

Question Number : 70 Question Id : 8643515830 Question Type : MCQ Option Shuffling : Yes Is

Question Mandatory : No

Correct Marks : 4 Wrong Marks : 1

The area bounded by the curve $4y^2 = x^2(4 - x)(x - 2)$ is equal to :

Options :

86435117497. $\frac{3\pi}{8}$

86435117498. $\frac{\pi}{16}$

86435117499. $\frac{\pi}{8}$

86435117500. $\frac{3\pi}{2}$

Question Number : 70 Question Id : 8643515830 Question Type : MCQ Option Shuffling : Yes Is Question Mandatory : No Correct Marks : 4 Wrong Marks : 1

$4y^2 = x^2(4-x)(x-2)$ বক্রৰ দ্বাৰা আবদ্ধ ক্ষেত্ৰৰ কালি সমান হ'ব :

Options :

86435117497. $\frac{3\pi}{8}$

86435117498. $\frac{\pi}{16}$

86435117499. $\frac{\pi}{8}$

86435117500. $\frac{3\pi}{2}$

Question Number : 71 Question Id : 8643515831 Question Type : MCQ Option Shuffling : Yes Is Question Mandatory : No Correct Marks : 4 Wrong Marks : 1

Let $g(x) = \int_0^x f(t)dt$, where f is continuous function in $[0, 3]$ such that $\frac{1}{3} \leq f(t) \leq 1$ for all $t \in [0, 1]$ and $0 \leq f(t) \leq \frac{1}{2}$ for all $t \in (1, 3]$. The largest possible interval in which $g(3)$ lies is :

Options :

86435117501. $\left[\frac{1}{3}, 2\right]$

86435117502. $\left[-1, -\frac{1}{2}\right]$

86435117503. $[1, 3]$

$$86435117504. \left[-\frac{3}{2}, -1 \right]$$

Question Number : 71 Question Id : 8643515831 Question Type : MCQ Option Shuffling : Yes Is Question Mandatory : No

Correct Marks : 4 Wrong Marks : 1

ধৰা হ'ল $g(x) = \int_0^x f(t)dt$, যত $[0, 3]$ অন্তৰালত f অবিচ্ছিন্ন যাতে $\frac{1}{3} \leq f(t) \leq 1$ সকলো $t \in [0, 1]$ ৰ বাবে, আৰু $0 \leq f(t) \leq \frac{1}{2}$, সকলো $t \in (1, 3]$ ৰ বাবে। সম্ভাৱ্য গৰিষ্ঠ অন্তৰালটো যত $g(3)$ থাকিব :

Options :

$$86435117501. \left[\frac{1}{3}, 2 \right]$$

$$86435117502. \left[-1, -\frac{1}{2} \right]$$

$$86435117503. [1, 3]$$

$$86435117504. \left[-\frac{3}{2}, -1 \right]$$

Question Number : 72 Question Id : 8643515832 Question Type : MCQ Option Shuffling : Yes Is Question Mandatory : No

Correct Marks : 4 Wrong Marks : 1

Let $f: \mathbb{R} \rightarrow \mathbb{R}$ be a function defined as

$$f(x) = \begin{cases} \frac{\sin(a+1)x + \sin 2x}{2x}, & \text{if } x < 0 \\ b, & \text{if } x = 0 \\ \frac{\sqrt{x + bx^3} - \sqrt{x}}{bx^{5/2}}, & \text{if } x > 0 \end{cases}$$

If f is continuous at $x=0$, then the value of $a+b$ is equal to :

Options :

86435117505. $-\frac{5}{2}$

86435117506. -3

86435117507. -2

86435117508. $-\frac{3}{2}$

Question Number : 72 Question Id : 8643515832 Question Type : MCQ Option Shuffling : Yes Is Question Mandatory : No

Correct Marks : 4 Wrong Marks : 1

ধরা হ'ল $f: \mathbb{R} \rightarrow \mathbb{R}$ এটা ফলন বর্ণিত যাতে

$$f(x) = \begin{cases} \frac{\sin(a+1)x + \sin 2x}{2x}, & \text{যদি } x < 0 \\ b, & \text{যদি } x = 0 \\ \frac{\sqrt{x + bx^3} - \sqrt{x}}{bx^{5/2}}, & \text{যদি } x > 0 \end{cases}$$

যদি f ফলনটো $x=0$ বিন্দুতে অবিচ্ছিন্ন, তেন্তে $a+b$ ৰ মান সমান হ'ব :

Options :

86435117505. $-\frac{5}{2}$

86435117506. -3 86435117507. -2 86435117508. $-\frac{3}{2}$

Question Number : 73 Question Id : 8643515833 Question Type : MCQ Option Shuffling : Yes Is Question Mandatory : No

Correct Marks : 4 Wrong Marks : 1

Let S_1 be the sum of first $2n$ terms of an arithmetic progression. Let S_2 be the sum of first $4n$ terms of the same arithmetic progression. If $(S_2 - S_1)$ is 1000, then the sum of the first $6n$ terms of the arithmetic progression is equal to :

Options :

86435117509. 7000

86435117510. 5000

86435117511. 3000

86435117512. 1000

Question Number : 73 Question Id : 8643515833 Question Type : MCQ Option Shuffling : Yes Is Question Mandatory : No

Correct Marks : 4 Wrong Marks : 1

ধৰা হ'ল সমান্তৰ প্ৰগতিৰ $1ম$ $2n$ টা পদৰ যোগফল S_1 । ধৰা হ'ল একে সমান্তৰ প্ৰগতিৰ $1ম$ $4n$ টা পদৰ যোগফল S_2 । যদি $(S_2 - S_1)$, 1000 হয়, তেন্তে সমান্তৰ প্ৰগতিৰ $1ম$ $6n$ টা পদৰ যোগফল সমান হ'ব :

Options :

86435117509. 7000

86435117510. 5000

86435117511. 3000

86435117512. 1000

Question Number : 74 Question Id : 8643515834 Question Type : MCQ Option Shuffling : Yes Is

Question Mandatory : No

Correct Marks : 4 Wrong Marks : 1

Let $S_1 : x^2 + y^2 = 9$ and $S_2 : (x - 2)^2 + y^2 = 1$. Then the locus of center of a variable circle S which touches S_1 internally and S_2 externally always passes through the points :

Options :

86435117513. $\left(2, \pm \frac{3}{2}\right)$

86435117514. $(0, \pm \sqrt{3})$

86435117515. $(1, \pm 2)$

86435117516. $\left(\frac{1}{2}, \pm \frac{\sqrt{5}}{2}\right)$

Question Number : 74 Question Id : 8643515834 Question Type : MCQ Option Shuffling : Yes Is

Question Mandatory : No

Correct Marks : 4 Wrong Marks : 1

ধৰা হ'ল $S_1 : x^2 + y^2 = 9$ আৰু $S_2 : (x - 2)^2 + y^2 = 1$, তেন্তে S_1 ক অন্তঃস্পৰ্শ আৰু S_2 ক বহিঃস্পৰ্শ কৰাকৈ এটা চলন্ত বৃত্ত S ৰ কেন্দ্ৰৰ সঞ্চাৰ পথটো পাব হৈ যোৱা বিন্দুটো হ'ব :

Options :

86435117513. $\left(2, \pm \frac{3}{2}\right)$

86435117514. $(0, \pm \sqrt{3})$

86435117515. $(1, \pm 2)$

86435117516. $\left(\frac{1}{2}, \pm \frac{\sqrt{5}}{2}\right)$

Question Number : 75 Question Id : 8643515835 Question Type : MCQ Option Shuffling : Yes Is

Question Mandatory : No

Correct Marks : 4 Wrong Marks : 1

Let the system of linear equations

$$4x + \lambda y + 2z = 0$$

$$2x - y + z = 0$$

$$\mu x + 2y + 3z = 0, \lambda, \mu \in \mathbb{R}.$$

has a non-trivial solution. Then which of the following is true ?

Options :

86435117517. $\lambda = 3, \mu \in \mathbb{R}$

86435117518. $\mu = -6, \lambda \in \mathbb{R}$

86435117519. $\lambda = 2, \mu \in \mathbb{R}$

86435117520. $\mu = 6, \lambda \in \mathbb{R}$

Question Number : 75 Question Id : 8643515835 Question Type : MCQ Option Shuffling : Yes Is

Question Mandatory : No

Correct Marks : 4 Wrong Marks : 1

ধৰা হ'ল

$$4x + \lambda y + 2z = 0$$

$$2x - y + z = 0$$

$$\mu x + 2y + 3z = 0, \lambda, \mu \in \mathbb{R}.$$

বৈখিক সমীকৰণ প্ৰণালীটোৰ এটা অশূন্য সমাধান আছে। তেন্তে তলৰ কোনটো সত্য ?

Options :

86435117517. $\lambda = 3, \mu \in \mathbb{R}$

86435117518. $\mu = -6, \lambda \in \mathbb{R}$

86435117519. $\lambda = 2, \mu \in \mathbb{R}$

86435117520. $\mu = 6, \lambda \in \mathbb{R}$

Question Number : 76 Question Id : 8643515836 Question Type : MCQ Option Shuffling : Yes Is

Question Mandatory : No

Correct Marks : 4 Wrong Marks : 1

Let $f: \mathbb{R} - \{3\} \rightarrow \mathbb{R} - \{1\}$ be defined by $f(x) = \frac{x-2}{x-3}$.

Let $g: \mathbb{R} \rightarrow \mathbb{R}$ be given as $g(x) = 2x - 3$. Then, the sum of all the values of x for which

$f^{-1}(x) + g^{-1}(x) = \frac{13}{2}$ is equal to.

Options :

86435117521. 2

86435117522. 5

86435117523. 3

86435117524. 7

Question Number : 76 Question Id : 8643515836 Question Type : MCQ Option Shuffling : Yes Is

Question Mandatory : No

Correct Marks : 4 Wrong Marks : 1

ধৰা হ'ল $f: \mathbb{R} - \{3\} \rightarrow \mathbb{R} - \{1\}$ বৰ্ণিত যাতে $f(x) = \frac{x-2}{x-3}$ । ধৰা হ'ল $g: \mathbb{R} \rightarrow \mathbb{R}$ বৰ্ণিত যাতে

$g(x) = 2x - 3$ । তেন্তে x ৰ সকলো মানৰ যোগফল যাৰ বাবে $f^{-1}(x) + g^{-1}(x) = \frac{13}{2}$ সমান হ'ব :

Options :

86435117521. 2

86435117522. 5

86435117523. 3

86435117524. 7

Question Number : 77 Question Id : 8643515837 Question Type : MCQ Option Shuffling : Yes Is

Question Mandatory : No

Correct Marks : 4 Wrong Marks : 1

Let a complex number be $w = 1 - \sqrt{3}i$. Let another complex number z be such that $|zw| = 1$ and $\arg(z) - \arg(w) = \frac{\pi}{2}$. Then the area of the triangle with vertices origin, z and w is equal

to :

Options :

86435117525. $\frac{1}{2}$

86435117526. 2

86435117527. $\frac{1}{4}$

86435117528. 4

Question Number : 77 Question Id : 8643515837 Question Type : MCQ Option Shuffling : Yes Is Question Mandatory : No Correct Marks : 4 Wrong Marks : 1

ধৰা হ'ল $w = 1 - \sqrt{3}i$ এটা জটিল সংখ্যা। ধৰা হ'ল আন এটা জটিল সংখ্যা z যাতে $|zw| = 1$ আৰু $\arg(z) - \arg(w) = \frac{\pi}{2}$ । তেন্তে শীৰ্ষবিন্দু মূলবিন্দু, z আৰু w বিশিষ্ট ত্ৰিভুজৰ কালি সমান হ'ব :

Options :

86435117525. $\frac{1}{2}$

86435117526. 2

86435117527. $\frac{1}{4}$

86435117528. 4

Question Number : 78 Question Id : 8643515838 Question Type : MCQ Option Shuffling : Yes Is

Question Mandatory : No

Correct Marks : 4 Wrong Marks : 1

Define a relation R over a class of $n \times n$ real matrices A and B as

“ ARB iff there exists a non-singular matrix P such that $PAP^{-1} = B$ ”.

Then which of the following is true ?

Options :

86435117529. R is reflexive, symmetric but not transitive

86435117530. R is reflexive, transitive but not symmetric

86435117531. R is symmetric, transitive but not reflexive,

86435117532. R is an equivalence relation

Question Number : 78 Question Id : 8643515838 Question Type : MCQ Option Shuffling : Yes Is

Question Mandatory : No

Correct Marks : 4 Wrong Marks : 1

ধৰা হ'ল $n \times n$ শ্ৰেণীৰ বাস্তৱ মৌলিকমত্ৰ A আৰু B ৰ ওপৰত R এটা সম্বন্ধ সংজ্ঞাবদ্ধ আছে যাতে

“ ARB যদি আৰু যদিহে এটা অলপ্ৰতিম মৌলিকমত্ৰ P আছে যাতে $PAP^{-1} = B$ ”, তেন্তে তলৰ কোনটো সত্য ?

Options :

86435117529. R প্ৰতিফলনীয়, প্ৰতিসম কিন্তু সংক্ৰামক নহয়।

86435117530. R প্ৰতিফলনীয়, সংক্ৰামক কিন্তু প্ৰতিসম নহয়।

86435117531. R প্ৰতিসম, সংক্ৰামক কিন্তু প্ৰতিফলনীয় নহয়।

86435117532. R এটা সমতুল্যতা সম্বন্ধ।

Question Number : 79 Question Id : 8643515839 Question Type : MCQ Option Shuffling : Yes Is

Question Mandatory : No

Correct Marks : 4 Wrong Marks : 1

Consider a hyperbola $H : x^2 - 2y^2 = 4$. Let the tangent at a point $P(4, \sqrt{6})$ meet the x -axis at

Q and latus rectum at $R(x_1, y_1)$, $x_1 > 0$. If F is a focus of H which is nearer to the point P , then

the area of ΔQFR is equal to .

Options :

86435117533. $\sqrt{6} - 1$

86435117534. $\frac{7}{\sqrt{6}} - 2$

86435117535. $4\sqrt{6} - 1$

86435117536. $4\sqrt{6}$

Question Number : 79 Question Id : 8643515839 Question Type : MCQ Option Shuffling : Yes Is

Question Mandatory : No

Correct Marks : 4 Wrong Marks : 1

ধৰা হ'ল $H : x^2 - 2y^2 = 4$ এটা পৰাবৃত্ত। ধৰা হ'ল $P (4, \sqrt{6})$ বিন্দুত টনা স্পৰ্শকডালে x অক্ষৰ Q বিন্দুত মিলিত হয় আৰু নাভিলম্বৰ $R (x_1, y_1), x_1 > 0$ বিন্দুত। যদি H ৰ নাভিৰ দ্বয় F যি P বিন্দুৰ ওচৰাওচৰি, তেন্তে ΔQFR ত্ৰিভুজৰ কালি সমান হ'ব :

Options :

86435117533. $\sqrt{6} - 1$

86435117534. $\frac{7}{\sqrt{6}} - 2$

86435117535. $4\sqrt{6} - 1$

86435117536. $4\sqrt{6}$

Question Number : 80 Question Id : 8643515840 Question Type : MCQ Option Shuffling : Yes Is

Question Mandatory : No

Correct Marks : 4 Wrong Marks : 1

Let \vec{a} and \vec{b} be two non-zero vectors perpendicular to each other and $|\vec{a}| = |\vec{b}|$. If

$|\vec{a} \times \vec{b}| = |\vec{a}|$, then the angle between the vectors $(\vec{a} + \vec{b} + (\vec{a} \times \vec{b}))$ and \vec{a} is equal to :

Options :

$$\cos^{-1}\left(\frac{1}{\sqrt{3}}\right)$$

86435117537.

$$\cos^{-1}\left(\frac{1}{\sqrt{2}}\right)$$

86435117538.

$$\sin^{-1}\left(\frac{1}{\sqrt{3}}\right)$$

86435117539.

$$\sin^{-1}\left(\frac{1}{\sqrt{6}}\right)$$

86435117540.

Question Number : 80 Question Id : 8643515840 Question Type : MCQ Option Shuffling : Yes Is Question Mandatory : No

Correct Marks : 4 Wrong Marks : 1

ধৰা হ'ল \vec{a} আৰু \vec{b} দুটা অশূন্য ভেক্টৰ যি এটা আনটোৰ ওপৰত লম্ব আৰু $|\vec{a}| = |\vec{b}|$ । যদি $|\vec{a} \times \vec{b}| = |\vec{a}|$,

তেন্তে $(\vec{a} + \vec{b} + (\vec{a} \times \vec{b}))$ আৰু \vec{a} ৰ মাজৰ কোণ সমান হ'ব :

Options :

$$\cos^{-1}\left(\frac{1}{\sqrt{3}}\right)$$

86435117537.

$$\cos^{-1}\left(\frac{1}{\sqrt{2}}\right)$$

86435117538.

$$\sin^{-1}\left(\frac{1}{\sqrt{3}}\right)$$

86435117539.

$$\sin^{-1}\left(\frac{1}{\sqrt{6}}\right)$$

86435117540.

Mathematics Section B

Section Id :	864351390
Section Number :	6
Section type :	Online
Mandatory or Optional :	Mandatory
Number of Questions :	10
Number of Questions to be attempted :	5
Section Marks :	20
Mark As Answered Required? :	Yes
Sub-Section Number :	1
Sub-Section Id :	864351390
Question Shuffling Allowed :	Yes

Question Number : 81 Question Id : 8643515841 Question Type : SA

Correct Marks : 4 Wrong Marks : 0

If $f(x)$ and $g(x)$ are two polynomials such that the polynomial $P(x) = f(x^3) + x g(x^3)$ is divisible by $x^2 + x + 1$, then $P(1)$ is equal to _____.

Response Type : Numeric

Evaluation Required For SA : Yes

Show Word Count : Yes

Answers Type : Equal

Text Areas : PlainText

Possible Answers :

100

Question Number : 81 Question Id : 8643515841 Question Type : SA

Correct Marks : 4 Wrong Marks : 0

যদি $f(x)$ আৰু $g(x)$ দুটা বহুপদ যাতে $P(x) = f(x^3) + x g(x^3)$ বহুপদটো $x^2 + x + 1$ ৰে বিভাজ্য, তেন্তে $P(1)$ সমান হ'ব _____।

Response Type : Numeric

Evaluation Required For SA : Yes

Show Word Count : Yes

Answers Type : Equal

Text Areas : PlainText

Possible Answers :

100

Question Number : 82 Question Id : 8643515842 Question Type : SA

Correct Marks : 4 Wrong Marks : 0

Let I be an identity matrix of order 2×2 and $P = \begin{bmatrix} 2 & -1 \\ 5 & -3 \end{bmatrix}$. Then the value of $n \in \mathbb{N}$ for which

$P^n = 5I - 8P$ is equal to _____.

Response Type : Numeric

Evaluation Required For SA : Yes

Show Word Count : Yes

Answers Type : Equal

Text Areas : PlainText

Possible Answers :

100

Question Number : 82 Question Id : 8643515842 Question Type : SA

Correct Marks : 4 Wrong Marks : 0

ধৰা হ'ল I এটা 2×2 মাত্ৰাৰ অভেদ মৌলিকমূৰ্ত্ত আৰু $P = \begin{bmatrix} 2 & -1 \\ 5 & -3 \end{bmatrix}$ তেন্তে $n \in \mathbb{N}$ মান সমান হ'ব যাৰ বাবে $P^n = 5I - 8P$

_____।

Response Type : Numeric

Evaluation Required For SA : Yes

Show Word Count : Yes

Answers Type : Equal

Text Areas : PlainText

Possible Answers :

100

Question Number : 83 Question Id : 8643515843 Question Type : SA

Correct Marks : 4 Wrong Marks : 0

The term independent of x in the expansion of $\left[\frac{x+1}{x^{2/3} - x^{1/3} + 1} - \frac{x-1}{x - x^{1/2}} \right]^{10}$, $x \neq 1$, is equal

to _____.

Response Type : Numeric

Evaluation Required For SA : Yes

Show Word Count : Yes

Answers Type : Equal

Text Areas : PlainText

Possible Answers :

100

Question Number : 83 Question Id : 8643515843 Question Type : SA

Correct Marks : 4 Wrong Marks : 0

$$\left[\frac{x+1}{x^{2/3} - x^{1/3} + 1} - \frac{x-1}{x - x^{1/2}} \right]^{10}, x \neq 1 \text{ ৰ বিস্তাৰত } x \text{ ৰহিত পদটোৰ সহগ সমান হ'ব } \underline{\hspace{2cm}} \text{।}$$

Response Type : Numeric

Evaluation Required For SA : Yes

Show Word Count : Yes

Answers Type : Equal

Text Areas : PlainText

Possible Answers :

100

Question Number : 84 Question Id : 8643515844 Question Type : SA

Correct Marks : 4 Wrong Marks : 0

$$\text{If } \sum_{r=1}^{10} r! (r^3 + 6r^2 + 2r + 5) = \alpha (11!),$$

then the value of α is equal to .

Response Type : Numeric

Evaluation Required For SA : Yes

Show Word Count : Yes

Answers Type : Equal

Text Areas : PlainText

Possible Answers :

100

Question Number : 84 Question Id : 8643515844 Question Type : SA

Correct Marks : 4 Wrong Marks : 0

$$\text{যদি } \sum_{r=1}^{10} r! (r^3 + 6r^2 + 2r + 5) = \alpha (11!), \text{ শ্ৰেণীবোৰ যোগফল হয়, তেন্তে } \alpha \text{ ৰ মান সমান হ'ব}$$

 ।

Response Type : Numeric

Evaluation Required For SA : Yes

Show Word Count : Yes

Answers Type : Equal

Text Areas : PlainText

Possible Answers :

100

Question Number : 85 Question Id : 8643515845 Question Type : SA

Correct Marks : 4 Wrong Marks : 0

Let $P(x)$ be a real polynomial of degree 3 which vanishes at $x = -3$. Let $P(x)$ have local

minima at $x = 1$, local maxima at $x = -1$ and $\int_{-1}^1 P(x) dx = 18$, then the sum of all the coefficients

of the polynomial $P(x)$ is equal to _____.

Response Type : Numeric

Evaluation Required For SA : Yes

Show Word Count : Yes

Answers Type : Equal

Text Areas : PlainText

Possible Answers :

100

Question Number : 85 Question Id : 8643515845 Question Type : SA

Correct Marks : 4 Wrong Marks : 0

ধৰা হ'ল $P(x)$ এটা 3 ঘাতৰ বহুপদ যি $x = -3$ ত শূন্য হৈ যায়। ধৰা হ'ল $P(x)$ ৰ $x = 1$ ত স্থানীয় লঘিষ্ঠ $x = -1$ আৰু

$\int_{-1}^1 P(x) dx = 18$ ত স্থানীয় গৰিষ্ঠ মান আছে। তেন্তে $P(x)$ বহুপদটোৰ সকলোবোৰ সহগৰ যোগফল সমান হ'ব

_____।

Response Type : Numeric

Evaluation Required For SA : Yes

Show Word Count : Yes

Answers Type : Equal

Text Areas : PlainText

Possible Answers :

100

Question Number : 86 Question Id : 8643515846 Question Type : SA

Correct Marks : 4 Wrong Marks : 0

Let $y = y(x)$ be the solution of the differential equation $x dy - y dx = \sqrt{(x^2 - y^2)} dx$, $x \geq 1$, with

$y(1) = 0$. If the area bounded by the line $x = 1$, $x = e^\pi$, $y = 0$ and $y = y(x)$ is $\alpha e^{2\pi} + \beta$, then the value of $10(\alpha + \beta)$ is equal to _____.

Response Type : Numeric

Evaluation Required For SA : Yes

Show Word Count : Yes

Answers Type : Equal

Text Areas : PlainText

Possible Answers :

100

Question Number : 86 Question Id : 8643515846 Question Type : SA

Correct Marks : 4 Wrong Marks : 0

ধৰা হ'ল $xdy - ydx = \sqrt{(x^2 - y^2)} dx$, $x \geq 1$, $y(1) = 0$ অৱকল সমীকৰণটোৰ $y = y(x)$ এটা সমাধান। যদি $x = 1$, $x = e^\pi$, $y = 0$ আৰু $y = y(x)$ ৰ দ্বাৰা আবদ্ধ ক্ষেত্ৰৰ কালি $\alpha e^{2\pi} + \beta$, তেন্তে $10(\alpha + \beta)$ ৰ মান সমান হ'ব _____।

Response Type : Numeric

Evaluation Required For SA : Yes

Show Word Count : Yes

Answers Type : Equal

Text Areas : PlainText

Possible Answers :

100

Question Number : 87 Question Id : 8643515847 Question Type : SA

Correct Marks : 4 Wrong Marks : 0

Let P be a plane containing the line $\frac{x-1}{3} = \frac{y+6}{4} = \frac{z+5}{2}$ and parallel to the line

$\frac{x-3}{4} = \frac{y-2}{-3} = \frac{z+5}{7}$. If the point $(1, -1, \alpha)$ lies on the plane P, then the value of $|5\alpha|$ is equal to _____.

Response Type : Numeric

Evaluation Required For SA : Yes

Show Word Count : Yes

Answers Type : Equal

Text Areas : PlainText

Possible Answers :

100

Question Number : 87 Question Id : 8643515847 Question Type : SA

Correct Marks : 4 Wrong Marks : 0

ধৰা হ'ল $\frac{x-1}{3} = \frac{y+6}{4} = \frac{z+5}{2}$ ৰেখা থাকাকৈ আৰু $\frac{x-3}{4} = \frac{y-2}{-3} = \frac{z+5}{7}$ ৰেখাৰ সমান্তৰাল হোৱা P এখন সমতল। যদি $(1, -1, \alpha)$ বিন্দুটো P সমতলত থাকে তেন্তে $|5\alpha|$ ৰ মান সমান হ'ব _____।

Response Type : Numeric**Evaluation Required For SA :** Yes**Show Word Count :** Yes**Answers Type :** Equal**Text Areas :** PlainText**Possible Answers :**

100

Question Number : 88 **Question Id :** 8643515848 **Question Type :** SA**Correct Marks :** 4 **Wrong Marks :** 0

Let the mirror image of the point $(1, 3, a)$ with respect to the plane $\vec{r} \cdot (2\hat{i} - \hat{j} + \hat{k}) - b = 0$ be $(-3, 5, 2)$. Then, the value of $|a + b|$ is equal to _____.

Response Type : Numeric**Evaluation Required For SA :** Yes**Show Word Count :** Yes**Answers Type :** Equal**Text Areas :** PlainText**Possible Answers :**

100

Question Number : 88 **Question Id :** 8643515848 **Question Type :** SA**Correct Marks :** 4 **Wrong Marks :** 0

$\vec{r} \cdot (2\hat{i} - \hat{j} + \hat{k}) - b = 0$ সমতল সাপেক্ষে $(1, 3, a)$ বিন্দুটোৰ দাপোন প্ৰতিবিন্দু হ'ল $(-3, 5, 2)$ । তেন্তে $|a + b|$ ৰ মান সমান হ'ব _____।

Response Type : Numeric**Evaluation Required For SA :** Yes**Show Word Count :** Yes**Answers Type :** Equal**Text Areas :** PlainText**Possible Answers :**

100

Question Number : 89 **Question Id :** 8643515849 **Question Type :** SA**Correct Marks :** 4 **Wrong Marks :** 0

Let ${}^n C_r$ denote the binomial coefficient of x^r in the expansion of $(1+x)^n$.

If $\sum_{k=0}^{10} (2^2 + 3k) {}^n C_k = \alpha \cdot 3^{10} + \beta \cdot 2^{10}$, $\alpha, \beta \in \mathbb{R}$, then $\alpha + \beta$ is equal to _____.

Response Type : Numeric**Evaluation Required For SA :** Yes**Show Word Count :** Yes**Answers Type :** Equal**Text Areas :** PlainText**Possible Answers :**

100

Question Number : 89 Question Id : 8643515849 Question Type : SA**Correct Marks : 4 Wrong Marks : 0**

ধৰা হ'ল $(1+x)^n$ ৰ বিস্তাৰত x^r ৰ সহগ nC_r য়ে বুজাইছে। যদি $\sum_{k=0}^{10} (2^2 + 3k) {}^nC_k = \alpha \cdot 3^{10} + \beta \cdot 2^{10}$, $\alpha, \beta \in \mathbb{R}$,

তেন্তে $\alpha + \beta$ সমান হ'ব _____ ।

Response Type : Numeric**Evaluation Required For SA :** Yes**Show Word Count :** Yes**Answers Type :** Equal**Text Areas :** PlainText**Possible Answers :**

100

Question Number : 90 Question Id : 8643515850 Question Type : SA**Correct Marks : 4 Wrong Marks : 0**

Let $f: \mathbb{R} \rightarrow \mathbb{R}$ satisfy the equation $f(x+y) = f(x) \cdot f(y)$ for all $x, y \in \mathbb{R}$ and $f(x) \neq 0$ for any $x \in \mathbb{R}$.

If the function f is differentiable at $x=0$ and $f'(0)=3$, then $\lim_{h \rightarrow 0} \frac{1}{h} (f(h) - 1)$ is equal to

_____.

Response Type : Numeric**Evaluation Required For SA :** Yes**Show Word Count :** Yes**Answers Type :** Equal**Text Areas :** PlainText**Possible Answers :**

100

Question Number : 90 Question Id : 8643515850 Question Type : SA**Correct Marks : 4 Wrong Marks : 0**

ধৰা হ'ল $f: \mathbf{R} \rightarrow \mathbf{R}$ য়ে $f(x+y) = f(x) \cdot f(y)$ সকলো $x, y \in \mathbf{R}$ ৰ বাবে আৰু $f(x) \neq 0$, যিকোনো $x \in \mathbf{R}$ ৰ বাবে। যদি

f ফলনটো $x=0$ বিন্দুত অৱকলনীয় আৰু $f'(0) = 3$ তেন্তে $\lim_{h \rightarrow 0} \frac{1}{h} (f(h) - 1)$ সমান হ'ব _____।

Response Type : Numeric

Evaluation Required For SA : Yes

Show Word Count : Yes

Answers Type : Equal

Text Areas : PlainText

Possible Answers :

100

