

# National Testing Agency

<b>Question Paper Name :</b>	B TECH EM 18th March 2021 Shift 2
<b>Subject Name :</b>	B TECH EM
<b>Creation Date :</b>	2021-03-18 19:51:25
<b>Duration :</b>	180
<b>Number of Questions :</b>	90
<b>Total Marks :</b>	300
<b>Display Marks:</b>	Yes

## B TECH EM

<b>Group Number :</b>	1
<b>Group Id :</b>	86435169
<b>Group Maximum Duration :</b>	0
<b>Group Minimum Duration :</b>	180
<b>Show Attended Group? :</b>	No
<b>Edit Attended Group? :</b>	No
<b>Break time :</b>	0
<b>Group Marks :</b>	300
<b>Is this Group for Examiner? :</b>	No

## Physics Section A

<b>Section Id :</b>	864351409
<b>Section Number :</b>	1
<b>Section type :</b>	Online
<b>Mandatory or Optional :</b>	Mandatory
<b>Number of Questions :</b>	20
<b>Number of Questions to be attempted :</b>	20
<b>Section Marks :</b>	80
<b>Mark As Answered Required? :</b>	Yes
<b>Sub-Section Number :</b>	1
<b>Sub-Section Id :</b>	864351409
<b>Question Shuffling Allowed :</b>	Yes

**Question Number : 1 Question Id : 8643516121 Question Type : MCQ Option Shuffling : Yes Is Question Mandatory : No Correct Marks : 4 Wrong Marks : 1**

Consider a sample of oxygen behaving like an ideal gas. At 300 K, the ratio of root mean square (rms) velocity to the average velocity of gas molecule would be :

(Molecular weight of oxygen is 32 g/mol;  $R = 8.3 \text{ J K}^{-1} \text{ mol}^{-1}$ )

**Options :**

$$\sqrt{\frac{3\pi}{8}}$$

86435118361.

$$\sqrt{\frac{8\pi}{3}}$$

86435118362.

$$\sqrt{\frac{8}{3}}$$

86435118363.

$$\sqrt{\frac{3}{3}}$$

86435118364.

**Question Number : 1 Question Id : 8643516121 Question Type : MCQ Option Shuffling : Yes Is Question Mandatory : No**

**Correct Marks : 4 Wrong Marks : 1**

ऑक्सीजनचा नमुना आदर्श वायूसारखा आहे असे समजा. 300 K ला वायूच्या रेणूसाठी वर्गमाध्य वर्गमूळ (rms) वेगाचे सरासरी वेगाबरोबरचे गुणोत्तर \_\_\_\_\_ असेल.

(ऑक्सीजनचे रेणूवजन 32 g/mol आहे;  $R = 8.3 \text{ J K}^{-1} \text{ mol}^{-1}$ )

**Options :**

$$\sqrt{\frac{3\pi}{8}}$$

86435118361.

$$\sqrt{\frac{8\pi}{3}}$$

86435118362.

$$\sqrt{\frac{8}{3}}$$

86435118363.

86435118364.  $\sqrt{\frac{3}{3}}$

**Question Number : 2 Question Id : 8643516122 Question Type : MCQ Option Shuffling : Yes Is Question Mandatory : No**

**Correct Marks : 4 Wrong Marks : 1**

An object of mass  $m_1$  collides with another object of mass  $m_2$ , which is at rest. After the collision the objects move with equal speeds in opposite direction. The ratio of the masses  $m_2 : m_1$  is :

**Options :**

86435118365. 1 : 1

86435118366. 1 : 2

86435118367. 2 : 1

86435118368. 3 : 1

**Question Number : 2 Question Id : 8643516122 Question Type : MCQ Option Shuffling : Yes Is Question Mandatory : No**

**Correct Marks : 4 Wrong Marks : 1**

$m_1$  वस्तुमानाची वस्तू  $m_2$  वस्तुमानाच्या वस्तू, जी स्थिर आहे, त्यावर आपटते. संघात झाल्यानंतर वस्तू विरुद्ध दिशेत सारख्याच वेगाने गतिमान होतात. वस्तुमानांचे  $m_2 : m_1$  हे गुणोत्तर \_\_\_\_\_ आहे.

**Options :**

86435118365. 1 : 1

86435118366. 1 : 2

86435118367. 2 : 1

86435118368. 3 : 1

**Question Number : 3 Question Id : 8643516123 Question Type : MCQ Option Shuffling : Yes Is Question Mandatory : No**

**Correct Marks : 4 Wrong Marks : 1**

A particle of mass  $m$  moves in a circular orbit under the central potential field,  $U(r) = -\frac{C}{r}$ ,

where  $C$  is a positive constant.

The correct radius – velocity graph of the particle's motion is :

Options :

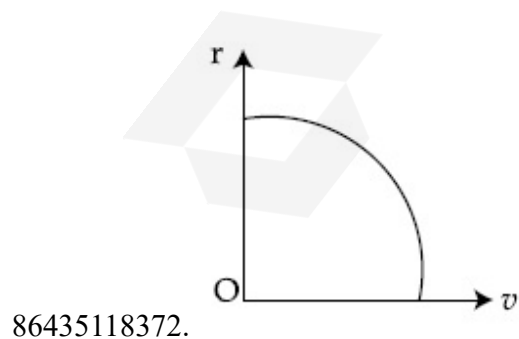
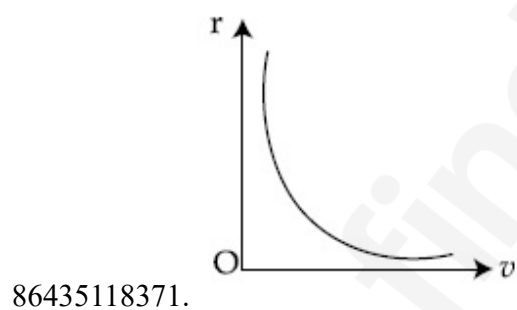
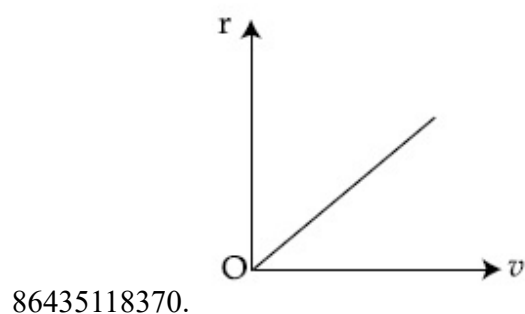
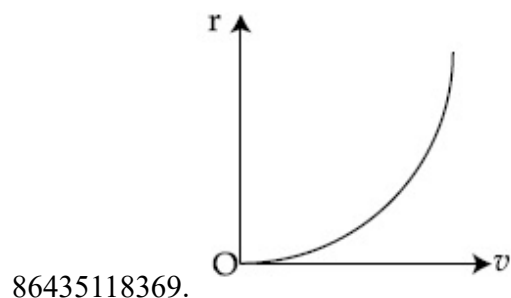

Question Number : 3 Question Id : 8643516123 Question Type : MCQ Option Shuffling : Yes Is Question Mandatory : No

Correct Marks : 4 Wrong Marks : 1

m वस्तुमानाचा एक कण वर्तुळाकार कक्षेत  $U(r) = -\frac{C}{r}$  ह्या मध्य विभव क्षेत्रात आहे जेथे C हा धन स्थिरांक आहे.

कणाच्या गतीसाठी योग्य त्रिज्या-वेग आलेख \_\_\_\_\_ आहे.

Options :

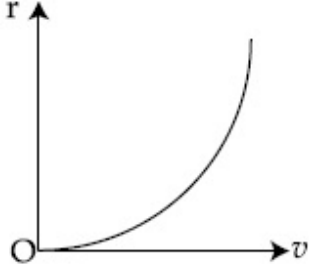

86435118369.

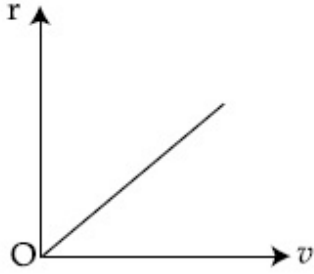

86435118370.

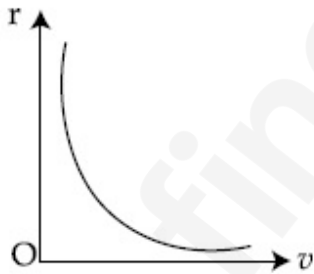

86435118371.

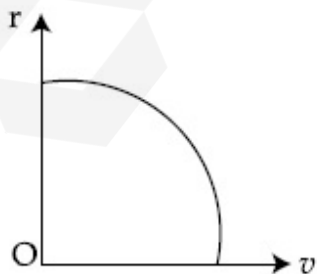

86435118372.

Question Number : 4 Question Id : 8643516124 Question Type : MCQ Option Shuffling : Yes Is Question Mandatory : No

Correct Marks : 4 Wrong Marks : 1

A solid cylinder of mass  $m$  is wrapped with an inextensible light string and, is placed on a rough inclined plane as shown in the figure. The frictional force acting between the cylinder and the inclined plane is :

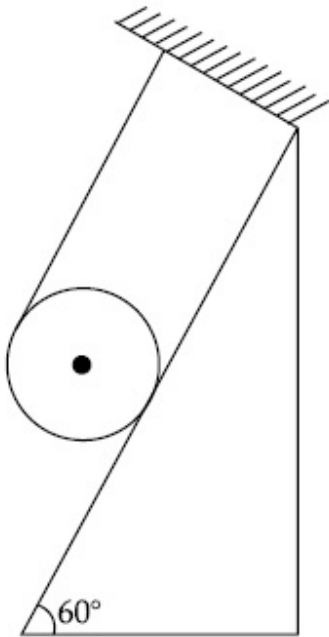

[The coefficient of static friction,  $\mu_s$ , is 0.4]

Options :

86435118373.  $\frac{mg}{5}$

86435118374.  $5 mg$

86435118375.  $\frac{7}{2} mg$

86435118376.  $0$

Question Number : 4 Question Id : 8643516124 Question Type : MCQ Option Shuffling : Yes Is Question Mandatory : No

Correct Marks : 4 Wrong Marks : 1

m वस्तुमानाचे एक भरीव नळकांडे न ताणली जाणाऱ्या हलक्या दोरीने गुंढाळले आहे व आकृतीत दाखविल्याप्रमाणे खडबडीत आनत प्रतलावर ठेवले आहे. नळकांडे व आनत प्रतल यामधील घर्षण बल \_\_\_\_\_ आहे.

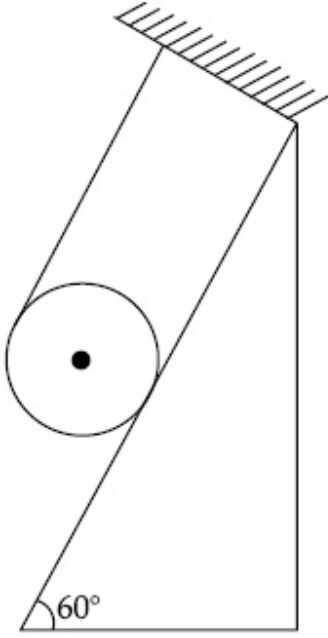

[स्थितिज घर्षण गुणांक,  $\mu_s$  0.4 आहे.]

Options :

86435118373.  $\frac{mg}{5}$

86435118374.  $5 mg$

86435118375.  $\frac{7}{2} mg$

86435118376.  $0$

Question Number : 5 Question Id : 8643516125 Question Type : MCQ Option Shuffling : Yes Is Question Mandatory : No

Correct Marks : 4 Wrong Marks : 1

If the angular velocity of earth's spin is increased such that the bodies at the equator start floating, the duration of the day would be approximately :

[Take  $g = 10 \text{ ms}^{-2}$ , the radius of earth,  $R = 6400 \times 10^3 \text{ m}$ , Take  $\pi = 3.14$ ]

Options :

86435118377. does not change

86435118378. 1200 minutes

86435118379. 60 minutes

86435118380. 84 minutes

**Question Number : 5 Question Id : 8643516125 Question Type : MCQ Option Shuffling : Yes Is Question Mandatory : No**

**Correct Marks : 4 Wrong Marks : 1**

जर पृथ्वीच्या फिरण्याचा कोनिय वेग वाढविला असा कि विषुववृत्तावरील वस्तू तरंगतील, दिवसाचा अवधी अंदाजे \_\_\_\_\_ असू शकेल.

[घ्या  $g = 10 \text{ ms}^{-2}$ , पृथ्वीची त्रिज्या,  $R = 6400 \times 10^3 \text{ m}$ ,  $\pi = 3.14$ ]

**Options :**

86435118377. बदलणार नाही

86435118378. 1200 मिनिटे

86435118379. 60 मिनिटे

86435118380. 84 मिनिटे

**Question Number : 6 Question Id : 8643516126 Question Type : MCQ Option Shuffling : Yes Is Question Mandatory : No**

**Correct Marks : 4 Wrong Marks : 1**

Consider a uniform wire of mass M and length L. It is bent into a semicircle. Its moment of inertia about a line perpendicular to the plane of the wire passing through the centre is :

**Options :**

86435118381.  $\frac{ML^2}{\pi^2}$

86435118382.  $\frac{1}{2} \frac{ML^2}{\pi^2}$

86435118383.  $\frac{1}{4} \frac{ML^2}{\pi^2}$

86435118384.  $\frac{2}{5} \frac{ML^2}{\pi^2}$

**Question Number : 6 Question Id : 8643516126 Question Type : MCQ Option Shuffling : Yes Is Question Mandatory : No**

**Correct Marks : 4 Wrong Marks : 1**

M वस्तुमानाची व L लांबीची एकसमान तार विचारात घ्या. ती अर्धवर्तुळकार वाकविली. तिचा प्रतलाला लंबरूप व मध्यातून जाणाऱ्या रेषेभोवती जडत्व आघूर्ण \_\_\_\_\_ आहे.

**Options :**

86435118381.  $\frac{ML^2}{\pi^2}$

86435118382.  $\frac{1}{2} \frac{ML^2}{\pi^2}$

86435118383.  $\frac{1}{4} \frac{ML^2}{\pi^2}$

86435118384.  $\frac{2}{5} \frac{ML^2}{\pi^2}$

**Question Number : 7 Question Id : 8643516127 Question Type : MCQ Option Shuffling : Yes Is Question Mandatory : No**

**Correct Marks : 4 Wrong Marks : 1**

The speed of electrons in a scanning electron microscope is  $1 \times 10^7 \text{ ms}^{-1}$ . If the protons having the same speed are used instead of electrons, then the resolving power of scanning proton microscope will be changed by a factor of :

**Options :**

86435118385. 1837

86435118386.  $\frac{1}{1837}$

86435118387.  $\frac{1}{\sqrt{1837}}$

86435118388.  $\sqrt{1837}$

**Question Number : 7 Question Id : 8643516127 Question Type : MCQ Option Shuffling : Yes Is Question Mandatory : No**

**Correct Marks : 4 Wrong Marks : 1**

क्रमविक्षण इलेक्ट्रॉन सूक्ष्मदर्शीतील इलेक्ट्रॉनचा वेग  $1 \times 10^7 \text{ ms}^{-1}$  आहे. जर इलेक्ट्रॉनच्या ऐवजी त्याच वेगाचे प्रोटॉन वापरले तर क्रमविक्षण प्रोटॉन सूक्ष्मदर्शीची वियोजन शक्ती \_\_\_\_\_ अवयवाने बदलेल.

**Options :**

86435118385. 1837

86435118386.  $\frac{1}{1837}$

86435118387.  $\frac{1}{\sqrt{1837}}$

86435118388.  $\sqrt{1837}$

**Question Number : 8 Question Id : 8643516128 Question Type : MCQ Option Shuffling : Yes Is Question Mandatory : No**

**Correct Marks : 4 Wrong Marks : 1**

The velocity - displacement graph of a particle is shown in the figure.

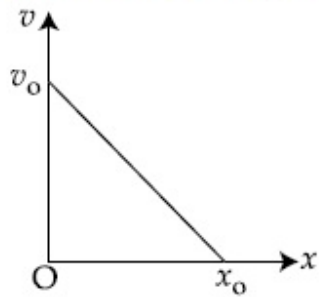

The acceleration - displacement graph of the same particle is represented by :

Options :

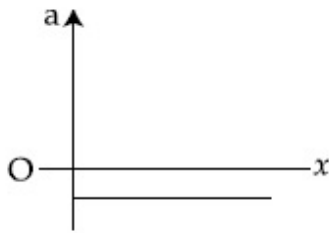

86435118389.

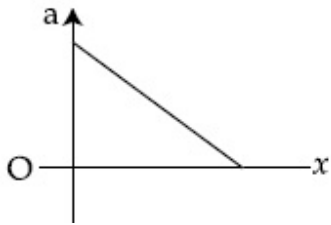

86435118390.

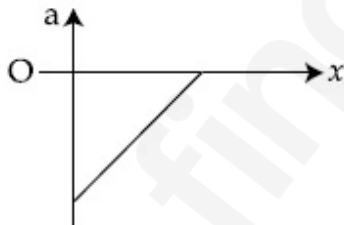

86435118391.

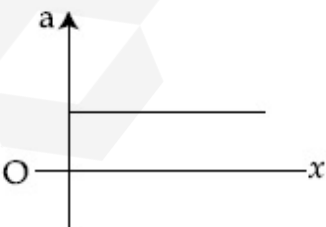

86435118392.

Question Number : 8 Question Id : 8643516128 Question Type : MCQ Option Shuffling : Yes Is Question Mandatory : No

Correct Marks : 4 Wrong Marks : 1

कणासाठी वेग-विस्थापन आलेख आकृतीत दाखविला आहे.

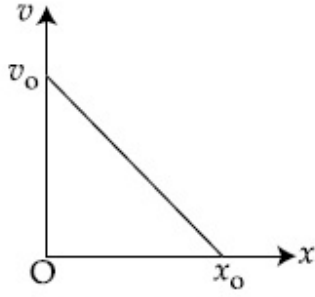

त्याच कणासाठी त्वरण-विस्थापन आलेख \_\_\_\_\_ असा दाखविता येईल.

Options :

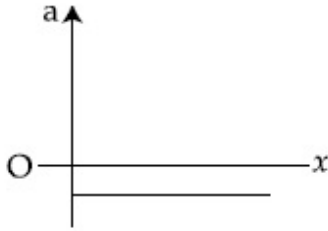

86435118389.

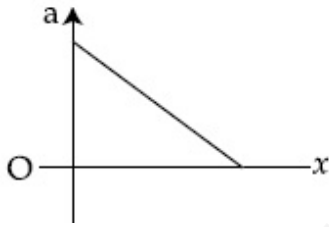

86435118390.

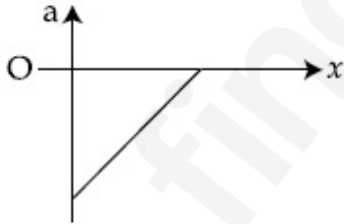

86435118391.

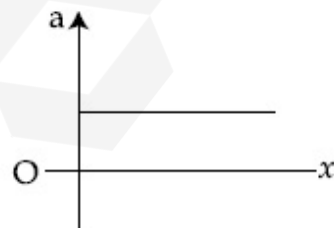

86435118392.

Question Number : 9 Question Id : 8643516129 Question Type : MCQ Option Shuffling : Yes Is Question Mandatory : No

Correct Marks : 4 Wrong Marks : 1

For an adiabatic expansion of an ideal gas, the fractional change in its pressure is equal to (where  $\gamma$  is the ratio of specific heats) :

**Options :**

$$-\gamma \frac{dV}{V}$$

86435118393.

$$-\gamma \frac{V}{dV}$$

86435118394.

$$-\frac{1}{\gamma} \frac{dV}{V}$$

86435118395.

$$\frac{dV}{V}$$

86435118396.

**Question Number : 9 Question Id : 8643516129 Question Type : MCQ Option Shuffling : Yes Is Question Mandatory : No**

**Correct Marks : 4 Wrong Marks : 1**

आदर्श वायूच्या समोष्ण प्रसरणासाठी, दाबाचा अपूर्णाकातील बदल \_\_\_\_\_ बरोबर आहे. (जेथे  $\gamma$  हे विशिष्ट उष्णतेचे गुणोत्तर आहे.)

**Options :**

$$-\gamma \frac{dV}{V}$$

86435118393.

$$-\gamma \frac{V}{dV}$$

86435118394.

$$-\frac{1}{\gamma} \frac{dV}{V}$$

86435118395.

$$\frac{dV}{V}$$

86435118396.

**Question Number : 10 Question Id : 8643516130 Question Type : MCQ Option Shuffling : Yes Is**

**Question Mandatory : No**

**Correct Marks : 4 Wrong Marks : 1**

The angular momentum of a planet of mass  $M$  moving around the sun in an elliptical orbit is

$\vec{L}$ . The magnitude of the areal velocity of the planet is :

**Options :**

86435118397.  $\frac{L}{M}$

86435118398.  $\frac{L}{2M}$

86435118399.  $\frac{2L}{M}$

86435118400.  $\frac{4L}{M}$

**Question Number : 10 Question Id : 8643516130 Question Type : MCQ Option Shuffling : Yes Is**

**Question Mandatory : No**

**Correct Marks : 4 Wrong Marks : 1**

$M$  वस्तुमानाचा ग्रह सूर्याभोवती विवृत्तीय कक्षेत गतिमान असून त्याचा कोनिय संवेग  $\vec{L}$  आहे. ग्रहाच्या क्षेत्रीय वेगाची किंमत \_\_\_\_\_ आहे.

**Options :**

86435118397.  $\frac{L}{M}$

86435118398.  $\frac{L}{2M}$

86435118399.  $\frac{2L}{M}$

$$86435118400. \frac{4L}{M}$$

**Question Number : 11 Question Id : 8643516131 Question Type : MCQ Option Shuffling : Yes Is**

**Question Mandatory : No**

**Correct Marks : 4 Wrong Marks : 1**

An ideal gas in a cylinder is separated by a piston in such a way that the entropy of one part is  $S_1$  and that of the other part is  $S_2$ . Given that  $S_1 > S_2$ . If the piston is removed then the total entropy of the system will be :

**Options :**

$$86435118401. S_1 \times S_2$$

$$86435118402. S_1 - S_2$$

$$86435118403. S_1 + S_2$$

$$86435118404. \frac{S_1}{S_2}$$

**Question Number : 11 Question Id : 8643516131 Question Type : MCQ Option Shuffling : Yes Is**

**Question Mandatory : No**

**Correct Marks : 4 Wrong Marks : 1**

नळकांड्यातील आदर्श वायू दृष्ट्या ने विभक्त असा केला कि एका भागाची एंट्रॉपी  $S_1$  व दूसऱ्या भागाची  $S_2$  आहे.

$S_1 > S_2$  दिले आहे. जर दृष्ट्या काढून टाकला तर संहतीची एकूण एंट्रॉपी \_\_\_\_\_ असेल.

**Options :**

$$86435118401. S_1 \times S_2$$

$$86435118402. S_1 - S_2$$

$$86435118403. S_1 + S_2$$

$$86435118404. \frac{S_1}{S_2}$$

Question Number : 12 Question Id : 8643516132 Question Type : MCQ Option Shuffling : Yes Is

Question Mandatory : No

Correct Marks : 4 Wrong Marks : 1

The function of time representing a simple harmonic motion with a period of  $\frac{\pi}{\omega}$  is :

Options :

86435118405.  $\sin(\omega t) + \cos(\omega t)$

86435118406.  $\sin^2(\omega t)$

86435118407.  $3 \cos\left(\frac{\pi}{4} - 2\omega t\right)$

86435118408.  $\cos(\omega t) + \cos(2\omega t) + \cos(3\omega t)$

Question Number : 12 Question Id : 8643516132 Question Type : MCQ Option Shuffling : Yes Is

Question Mandatory : No

Correct Marks : 4 Wrong Marks : 1

काल  $\frac{\pi}{\omega}$  असताना सरल आवर्त गतिच्या वेळेचे फल \_\_\_\_\_ असे दाखविले जाते.

Options :

86435118405.  $\sin(\omega t) + \cos(\omega t)$

86435118406.  $\sin^2(\omega t)$

86435118407.  $3 \cos\left(\frac{\pi}{4} - 2\omega t\right)$

86435118408.  $\cos(\omega t) + \cos(2\omega t) + \cos(3\omega t)$

Question Number : 13 Question Id : 8643516133 Question Type : MCQ Option Shuffling : Yes Is

Question Mandatory : No

Correct Marks : 4 Wrong Marks : 1

In a series LCR circuit, the inductive reactance ( $X_L$ ) is  $10 \Omega$  and the capacitive reactance ( $X_C$ ) is  $4 \Omega$ . The resistance ( $R$ ) in the circuit is  $6 \Omega$ .

The power factor of the circuit is :

Options :

86435118409.  $\frac{1}{\sqrt{2}}$

86435118410.  $\frac{\sqrt{3}}{2}$

86435118411.  $\frac{1}{2}$

86435118412.  $\frac{1}{2\sqrt{2}}$

Question Number : 13 Question Id : 8643516133 Question Type : MCQ Option Shuffling : Yes Is Question Mandatory : No

Correct Marks : 4 Wrong Marks : 1

LCR एकसरीतील परिपथात, प्रेरण प्ररोध ( $X_L$ )  $10 \Omega$  आहे व धारकता प्ररोध ( $X_C$ )  $4 \Omega$  आहे. परिपथातील रोध ( $R$ ) हा  $6 \Omega$  आहे. परिपथाचा शक्ती अवयव \_\_\_\_\_ आहे.

Options :

86435118409.  $\frac{1}{\sqrt{2}}$

86435118410.  $\frac{\sqrt{3}}{2}$

86435118411.  $\frac{1}{2}$

86435118412.  $\frac{1}{2\sqrt{2}}$

Question Number : 14 Question Id : 8643516134 Question Type : MCQ Option Shuffling : Yes Is Question Mandatory : No

**Correct Marks : 4 Wrong Marks : 1**

Which of the following statements are correct ?

- (A) Electric monopoles do not exist whereas magnetic monopoles exist.
- (B) Magnetic field lines due to a solenoid at its ends and outside cannot be completely straight and confined.
- (C) Magnetic field lines are completely confined within a toroid.
- (D) Magnetic field lines inside a bar magnet are not parallel.
- (E)  $\chi = -1$  is the condition for a perfect diamagnetic material, where  $\chi$  is its magnetic susceptibility.

Choose the correct answer from the options given below :

**Options :**

86435118413. (B) and (D) only

86435118414. (B) and (C) only

86435118415. (A) and (B) only

86435118416. (C) and (E) only

**Question Number : 14 Question Id : 8643516134 Question Type : MCQ Option Shuffling : Yes Is**

**Question Mandatory : No**

**Correct Marks : 4 Wrong Marks : 1**

खालीलपैकी कोणते विधान योग्य आहे ?

- (A) विद्युत एकध्रुव नसतो पण चुंबकीय एकध्रुव असतो.
- (B) सोलेनॉईडमुळे चुंबकीय क्षेत्रातील रेषा टोकाशी व बाहेर पूर्णपणे सरळ किंवा व्याप्त नसतात.
- (C) टोर्नॉईडमध्ये चुंबकीय क्षेत्र रेषा पूर्णपणे व्याप्त असतात.
- (D) चुंबक पट्टीमध्ये चुंबकीय क्षेत्र रेषा समांतर नसतात.
- (E) पूर्ण प्रतिचुंबकीय पदार्थासाठी  $\chi = -1$  ही अट आहे, जेथे  $\chi$  हि चुंबकीय प्रभाव्यता आहे.

खाली दिलेल्या पर्यायातून योग्य उत्तर निवडा.

**Options :**

86435118413. (B) व (D) फक्त

86435118414. (B) व (C) फक्त

86435118415. (A) व (B) फक्त

86435118416. (C) व (E) फक्त

**Question Number : 15 Question Id : 8643516135 Question Type : MCQ Option Shuffling : Yes Is**

**Question Mandatory : No**

**Correct Marks : 4 Wrong Marks : 1**

The correct relation between  $\alpha$  (ratio of collector current to emitter current) and  $\beta$  (ratio of collector current to base current) of a transistor is :

**Options :**

$$\beta = \frac{\alpha}{1 + \alpha}$$

86435118417.

$$\alpha = \frac{\beta}{1 - \alpha}$$

86435118418.

$$\beta = \frac{1}{1 - \alpha}$$

86435118419.

$$\alpha = \frac{\beta}{1 + \beta}$$

86435118420.

**Question Number : 15 Question Id : 8643516135 Question Type : MCQ Option Shuffling : Yes Is**

**Question Mandatory : No**

**Correct Marks : 4 Wrong Marks : 1**

ट्रान्झिस्टरसाठी  $\alpha$  (ग्राही धाराचे उत्सर्जी धारेबरोबरचे गुणोत्तर) व  $\beta$  (ग्राही धारेचे आधार धारेबरोबरचे गुणोत्तर) यामधील योग्य संबंध \_\_\_\_\_ आहे.

**Options :**

$$\beta = \frac{\alpha}{1 + \alpha}$$

86435118417.

$$\alpha = \frac{\beta}{1 - \alpha}$$

86435118418.

$$\beta = \frac{1}{1 - \alpha}$$

86435118419.

$$\alpha = \frac{\beta}{1 + \beta}$$

86435118420.

**Question Number : 16 Question Id : 8643516136 Question Type : MCQ Option Shuffling : Yes Is Question Mandatory : No**

**Correct Marks : 4 Wrong Marks : 1**

A proton and an  $\alpha$ -particle, having kinetic energies  $K_p$  and  $K_\alpha$  respectively, enter into a magnetic field at right angles.

The ratio of the radii of trajectory of proton to that of  $\alpha$ -particle is 2 : 1. The ratio of  $K_p : K_\alpha$  is :

**Options :**

86435118421. 1 : 4

86435118422. 4 : 1

86435118423. 8 : 1

86435118424. 1 : 8

**Question Number : 16 Question Id : 8643516136 Question Type : MCQ Option Shuffling : Yes Is Question Mandatory : No**

**Correct Marks : 4 Wrong Marks : 1**

प्रोटॉन व  $\alpha$  कण ह्यांची गतिज ऊर्जा  $K_p$  व  $K_\alpha$  अनुक्रमे असून ते चुंबकीय क्षेत्रात काटकोनात शिरतात. प्रोटॉनच्या विक्षेपथाच्या बरोबर  $\alpha$  कणाबरोबरचे त्रिज्येचे गुणोत्तर 2 : 1 आहे.  $K_p : K_\alpha$  चे गुणोत्तर \_\_\_\_\_ आहे.

**Options :**

86435118421. 1 : 4

86435118422. 4 : 1

86435118423. 8 : 1

86435118424. 1 : 8

**Question Number : 17 Question Id : 8643516137 Question Type : MCQ Option Shuffling : Yes Is**

**Question Mandatory : No**

**Correct Marks : 4 Wrong Marks : 1**

Three rays of light, namely red (R), green (G) and blue (B) are incident on the face PQ of a right angled prism PQR as shown in the figure.

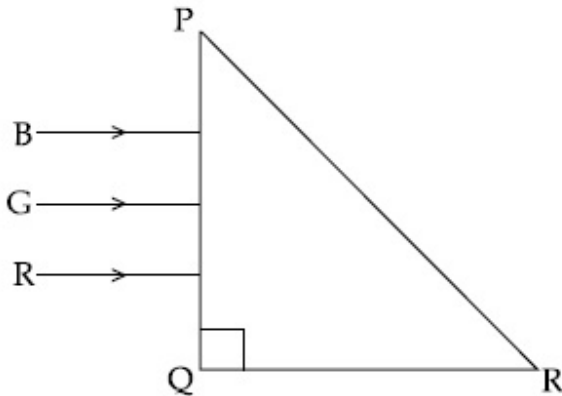

The refractive indices of the material of the prism for red, green and blue wavelength are 1.27, 1.42 and 1.49 respectively. The colour of the ray(s) emerging out of the face PR is :

**Options :**

86435118425. blue and green

86435118426. blue

86435118427. green

86435118428. red

**Question Number : 17 Question Id : 8643516137 Question Type : MCQ Option Shuffling : Yes Is**

**Question Mandatory : No**

**Correct Marks : 4 Wrong Marks : 1**

तीन प्रकाशकिरण लाल (R), हिरवा (G) व निळा (B) हे PQR ह्या काटकोन त्रिकोण प्रिझमच्या PQ पृष्ठभागावर आपाती आहेत.

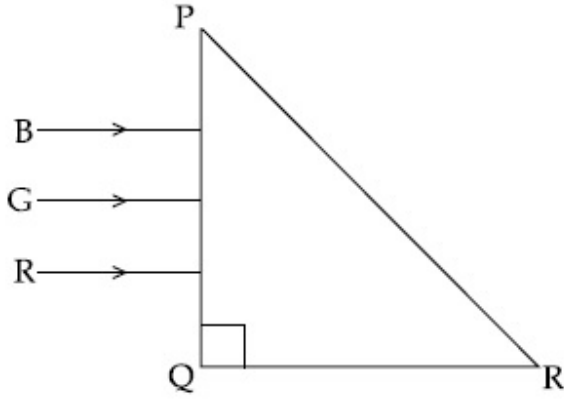

प्रिझमच्या पदार्थासाठी लाल, हिरवा व निळ्या तरंगलांबींसाठी अपवर्तनांक अनुक्रमे 1.27, 1.42 व 1.49 आहे. PR पृष्ठभागातून बाहेर पडणाऱ्या किरणांचा रंग \_\_\_\_\_ आहे.

**Options :**

86435118425. निळा व हिरवा

86435118426. निळा

86435118427. हिरवा

86435118428. लाल

**Question Number : 18 Question Id : 8643516138 Question Type : MCQ Option Shuffling : Yes Is**

**Question Mandatory : No**

**Correct Marks : 4 Wrong Marks : 1**

The time taken for the magnetic energy to reach 25% of its maximum value, when a solenoid of resistance R, inductance L is connected to a battery, is :

**Options :**

86435118429.  $\frac{L}{R} \ln 2$

86435118430.  $\frac{L}{R} \ln 5$

$$\frac{L}{R} \ln 10$$

86435118431.

infinite

86435118432.

**Question Number : 18 Question Id : 8643516138 Question Type : MCQ Option Shuffling : Yes Is Question Mandatory : No**

**Correct Marks : 4 Wrong Marks : 1**

जेव्हा R रोध, L प्रेरित्रचा सोलेनॉइड बॅटरीस जोडले तेव्हा चुंबकीय ऊर्जा महत्तम मूल्याच्या 25% पर्यंत पोहोचण्यासाठी घेतलेला वेळ \_\_\_\_\_ आहे.

**Options :**

$$\frac{L}{R} \ln 2$$

86435118429.

$$\frac{L}{R} \ln 5$$

86435118430.

$$\frac{L}{R} \ln 10$$

86435118431.

अनंत

86435118432.

**Question Number : 19 Question Id : 8643516139 Question Type : MCQ Option Shuffling : Yes Is Question Mandatory : No**

**Correct Marks : 4 Wrong Marks : 1**

A plane electromagnetic wave propagating along  $y$ -direction can have the following pair of electric field  $(\vec{E})$  and magnetic field  $(\vec{B})$  components.

**Options :**

$$E_y, B_y \text{ or } E_z, B_z$$

86435118433.

$$E_x, B_y \text{ or } E_y, B_x$$

86435118434.

86435118435.  $E_x, B_z$  or  $E_z, B_x$

86435118436.  $E_y, B_x$  or  $E_x, B_y$

**Question Number : 19 Question Id : 8643516139 Question Type : MCQ Option Shuffling : Yes Is**

**Question Mandatory : No**

**Correct Marks : 4 Wrong Marks : 1**

$y$ -दिशेत जाणाऱ्या प्रतल विद्युत चुंबकीय तरंगासाठी विद्युत क्षेत्र ( $\vec{E}$ ) व चुंबकीय क्षेत्र ( $\vec{B}$ ) ह्यांच्या घटकांच्या

खालील जोड्या शक्य आहेत.

**Options :**

86435118433.  $E_y, B_y$  किंवा  $E_z, B_z$

86435118434.  $E_x, B_y$  किंवा  $E_y, B_x$

86435118435.  $E_x, B_z$  किंवा  $E_z, B_x$

86435118436.  $E_y, B_x$  किंवा  $E_x, B_y$

**Question Number : 20 Question Id : 8643516140 Question Type : MCQ Option Shuffling : Yes Is**

**Question Mandatory : No**

**Correct Marks : 4 Wrong Marks : 1**

The decay of a proton to neutron is :

**Options :**

86435118437. not possible as proton mass is less than the neutron mass

86435118438. possible only inside the nucleus

86435118439. always possible as it is associated only with  $\beta^+$  decay

86435118440. not possible but neutron to proton conversion is possible

**Question Number : 20 Question Id : 8643516140 Question Type : MCQ Option Shuffling : Yes Is**

**Question Mandatory : No**

Correct Marks : 4 Wrong Marks : 1

प्रोटॉन ते न्यूट्रॉनचा ऱ्हास \_\_\_\_\_ आहे.

Options :

86435118437. शक्य नाही कारण प्रोटॉनचे वस्तुमान न्यूट्रॉनच्या वस्तुमानापेक्षा कमी आहे.

86435118438. फक्त केंद्रकाच्या आत शक्य आहे.

86435118439. नेहमी शक्य आहे कारण ते  $\beta^+$  ऱ्हासाबरोबर संबंधित आहे.

86435118440. शक्य नाही पण न्यूट्रॉन ते प्रोटॉन रूपांतर शक्य आहे.

## Physics Section B

Section Id :	864351410
Section Number :	2
Section type :	Online
Mandatory or Optional :	Mandatory
Number of Questions :	10
Number of Questions to be attempted :	5
Section Marks :	20
Mark As Answered Required? :	Yes
Sub-Section Number :	1
Sub-Section Id :	864351410
Question Shuffling Allowed :	Yes

Question Number : 21 Question Id : 8643516141 Question Type : SA

Correct Marks : 4 Wrong Marks : 0

The projectile motion of a particle of mass 5 g is shown in the figure.

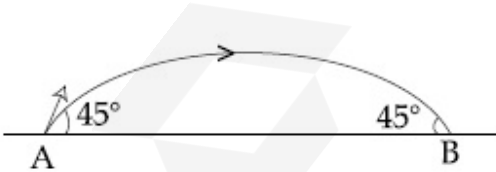

The initial velocity of the particle is  $5\sqrt{2} \text{ ms}^{-1}$  and the air resistance is assumed to be negligible.

The magnitude of the change in momentum between the points A and B is  $x \times 10^{-2} \text{ kgms}^{-1}$ .

The value of  $x$ , to the nearest integer, is \_\_\_\_\_.

Response Type : Numeric

Evaluation Required For SA : Yes

Show Word Count : Yes

**Answers Type :** Equal

**Text Areas :** PlainText

**Possible Answers :**

100

**Question Number :** 21 **Question Id :** 8643516141 **Question Type :** SA

**Correct Marks :** 4 **Wrong Marks :** 0

आकृतीत 5 g वस्तुमानाच्या कणाची प्रक्षेपास्त्र गति दाखविली आहे.

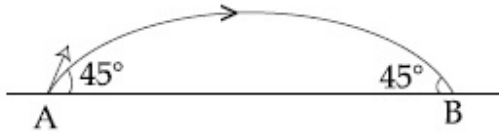

कणाचा सुरुवातीचा वेग  $5\sqrt{2} \text{ ms}^{-1}$  आहे व हवेचा रोध नगण्य आहे असे माना. A व B बिंदूमधील संवेगाच्या बदलाची किंमत  $x \times 10^{-2} \text{ kgms}^{-1}$  आहे.  $x$  चे मूल्य, जवळच्या पूर्णांकापर्यंत \_\_\_\_\_ आहे.

**Response Type :** Numeric

**Evaluation Required For SA :** Yes

**Show Word Count :** Yes

**Answers Type :** Equal

**Text Areas :** PlainText

**Possible Answers :**

100

**Question Number :** 22 **Question Id :** 8643516142 **Question Type :** SA

**Correct Marks :** 4 **Wrong Marks :** 0

An infinite number of point charges, each carrying  $1 \mu\text{C}$  charge, are placed along the  $y$ -axis at  $y = 1 \text{ m}, 2 \text{ m}, 4 \text{ m}, 8 \text{ m} \dots$

The total force on a  $1 \text{ C}$  point charge, placed at the origin, is  $x \times 10^3 \text{ N}$ .

The value of  $x$ , to the nearest integer, is \_\_\_\_\_.

[Take  $\frac{1}{4\pi\epsilon_0} = 9 \times 10^9 \text{ Nm}^2/\text{C}^2$ ]

**Response Type :** Numeric

**Evaluation Required For SA :** Yes

**Show Word Count :** Yes

**Answers Type :** Equal

**Text Areas :** PlainText

**Possible Answers :**

100

Question Number : 22 Question Id : 8643516142 Question Type : SA

Correct Marks : 4 Wrong Marks : 0

$y$ -अक्षावर  $y = 1 \text{ m}, 2 \text{ m}, 4 \text{ m}, 8 \text{ m}, \dots$  वर प्रत्येकी  $1 \mu\text{C}$  प्रभाराचे असंख्य बिंदू प्रभार ठेवले आहेत.

आरंभावर ठेवलेल्या  $1 \text{ C}$  बिंदू प्रभारावर एकूण बल  $x \times 10^3 \text{ N}$  आहे.

$x$  चे मूल्य, जवळच्या पूर्णांकापर्यंत \_\_\_\_\_ आहे.

$$\left[ \frac{1}{4\pi\epsilon_0} = 9 \times 10^9 \text{ Nm}^2/\text{C}^2 \text{ घ्या.} \right]$$

Response Type : Numeric

Evaluation Required For SA : Yes

Show Word Count : Yes

Answers Type : Equal

Text Areas : PlainText

Possible Answers :

100

Question Number : 23 Question Id : 8643516143 Question Type : SA

Correct Marks : 4 Wrong Marks : 0

Two wires of same length and thickness having specific resistances  $6 \Omega \text{ cm}$  and  $3 \Omega \text{ cm}$  respectively are connected in parallel. The effective resistivity is  $\rho \Omega \text{ cm}$ . The value of  $\rho$ , to the nearest integer, is \_\_\_\_\_.

Response Type : Numeric

Evaluation Required For SA : Yes

Show Word Count : Yes

Answers Type : Equal

Text Areas : PlainText

Possible Answers :

100

Question Number : 23 Question Id : 8643516143 Question Type : SA

Correct Marks : 4 Wrong Marks : 0

दोन सारख्या लांबीच्या व जाडीच्या तारांचा विशिष्ट रोध अनुक्रमे  $6 \Omega \text{ cm}$  व  $3 \Omega \text{ cm}$  असून त्या समांतर जोडल्या आहेत. परिणामी रोधिता  $\rho \Omega \text{ cm}$  आहे.  $\rho$  चे मूल्य, जवळच्या पूर्णांकापर्यंत \_\_\_\_\_ आहे.

Response Type : Numeric

Evaluation Required For SA : Yes

Show Word Count : Yes

Answers Type : Equal

Text Areas : PlainText

Possible Answers :

100

**Question Number : 24 Question Id : 8643516144 Question Type : SA**

**Correct Marks : 4 Wrong Marks : 0**

A ball of mass 4 kg, moving with a velocity of  $10 \text{ ms}^{-1}$ , collides with a spring of length 8 m and force constant  $100 \text{ Nm}^{-1}$ . The length of the compressed spring is  $x$  m. The value of  $x$ , to the nearest integer, is \_\_\_\_\_.

**Response Type : Numeric**

**Evaluation Required For SA : Yes**

**Show Word Count : Yes**

**Answers Type : Equal**

**Text Areas : PlainText**

**Possible Answers :**

100

**Question Number : 24 Question Id : 8643516144 Question Type : SA**

**Correct Marks : 4 Wrong Marks : 0**

4 kg वस्तुमानाचा चेंडू,  $10 \text{ ms}^{-1}$  वेगाने गतिमान असून 8 m लांबीच्या व  $100 \text{ Nm}^{-1}$  बल स्थिरांक असलेल्या स्प्रिंगवर आपटतो. दाबलेल्या स्प्रिंगची लांबी  $x$  m आहे.  $x$  चे मूल्य, जवळच्या पूर्णांकापर्यंत \_\_\_\_\_ आहे.

**Response Type : Numeric**

**Evaluation Required For SA : Yes**

**Show Word Count : Yes**

**Answers Type : Equal**

**Text Areas : PlainText**

**Possible Answers :**

100

**Question Number : 25 Question Id : 8643516145 Question Type : SA**

**Correct Marks : 4 Wrong Marks : 0**

The typical output characteristics curve for a transistor working in the common-emitter configuration is shown in the figure.

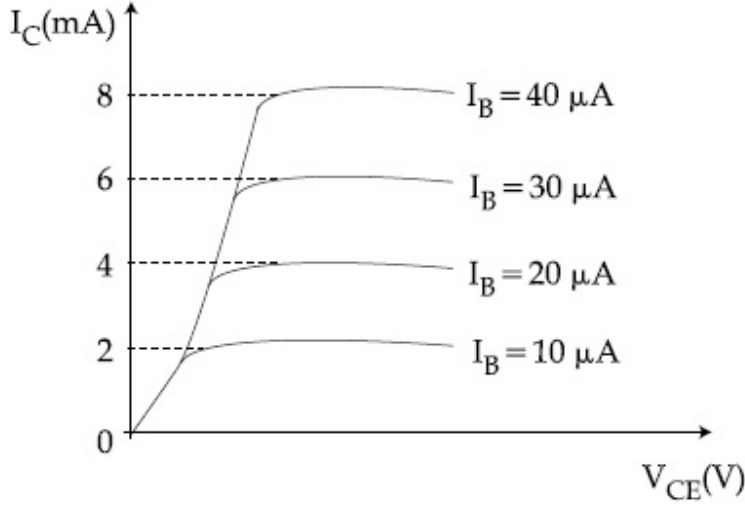

The estimated current gain from the figure is \_\_\_\_\_.

**Response Type :** Numeric

**Evaluation Required For SA :** Yes

**Show Word Count :** Yes

**Answers Type :** Equal

**Text Areas :** PlainText

**Possible Answers :**

100

**Question Number :** 25 **Question Id :** 8643516145 **Question Type :** SA

**Correct Marks :** 4 **Wrong Marks :** 0

सामाईक उत्सर्जी संरूपणात कार्य करणाऱ्या ट्रांझिस्टरसाठी नमुनेदार निष्पन्न लक्षणिक वक्र आकृतीत दाखविली आहे.

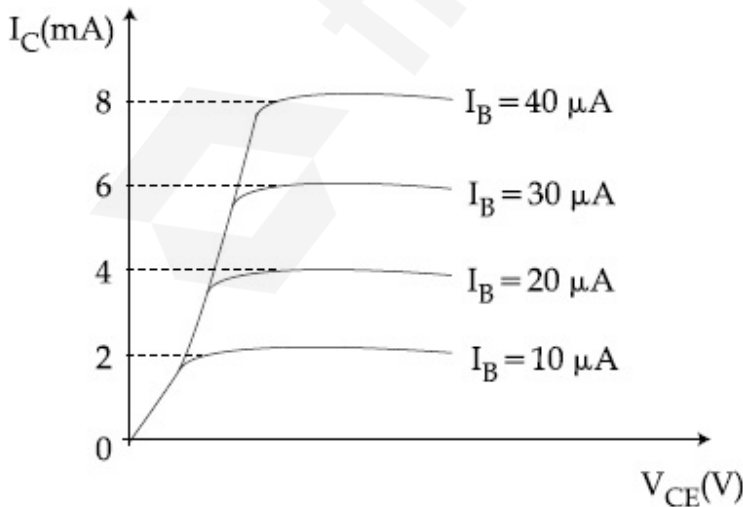

आकृतीवरून अंदाजित धारा वर्धन \_\_\_\_\_ आहे.

**Response Type :** Numeric

**Evaluation Required For SA :** Yes

**Show Word Count :** Yes

**Answers Type :** Equal

**Text Areas :** PlainText

**Possible Answers :**

100

**Question Number :** 26 **Question Id :** 8643516146 **Question Type :** SA

**Correct Marks :** 4 **Wrong Marks :** 0

Consider a 72 cm long wire AB as shown in the figure. The galvanometer jockey is placed at P on AB at a distance  $x$  cm from A. The galvanometer shows zero deflection.

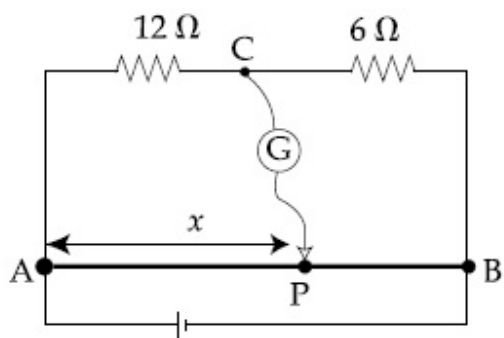

The value of  $x$ , to the nearest integer, is \_\_\_\_\_.

**Response Type :** Numeric

**Evaluation Required For SA :** Yes

**Show Word Count :** Yes

**Answers Type :** Equal

**Text Areas :** PlainText

**Possible Answers :**

100

**Question Number :** 26 **Question Id :** 8643516146 **Question Type :** SA

**Correct Marks :** 4 **Wrong Marks :** 0

आकृतीत दाखविल्याप्रमाणे 72 cm लांब AB तार विचारात घ्या. गॅल्व्हानोमीटरचा जॉकी AB वर A बिंदूपासून  $x$  अंतरावर P बिंदूवर ठेवला आहे. गॅल्व्हानोमीटर शून्य विचलन दाखवितो.

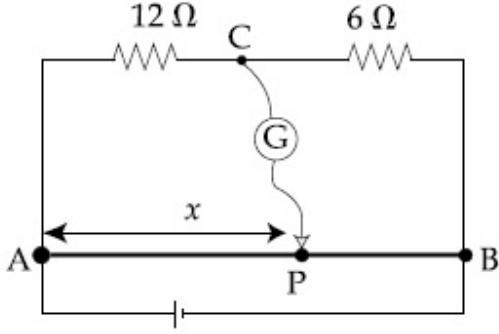

$x$  चे मूल्य जवळच्या पूर्णांकापर्यंत \_\_\_\_\_ आहे.

**Response Type :** Numeric

**Evaluation Required For SA :** Yes

**Show Word Count :** Yes

**Answers Type :** Equal

**Text Areas :** PlainText

**Possible Answers :**

100

**Question Number :** 27 **Question Id :** 8643516147 **Question Type :** SA

**Correct Marks :** 4 **Wrong Marks :** 0

A galaxy is moving away from the earth at a speed of  $286 \text{ kms}^{-1}$ . The shift in the wavelength of a redline at  $630 \text{ nm}$  is  $x \times 10^{-10} \text{ m}$ .

The value of  $x$ , to the nearest integer, is \_\_\_\_\_.

[Take the value of speed of light  $c$ , as  $3 \times 10^8 \text{ ms}^{-1}$ ]

**Response Type :** Numeric

**Evaluation Required For SA :** Yes

**Show Word Count :** Yes

**Answers Type :** Equal

**Text Areas :** PlainText

**Possible Answers :**

100

**Question Number :** 27 **Question Id :** 8643516147 **Question Type :** SA

**Correct Marks :** 4 **Wrong Marks :** 0

एक दिर्घिका पृथ्वीपासून  $286 \text{ kms}^{-1}$  वेगाने दूर जात आहे.  $630 \text{ nm}$  ला लाल रेषेचे तरंगलांबीतील विस्थापन  $x \times 10^{-10} \text{ m}$  आहे.  $x$  चे मूल्य जवळच्या पूर्णांकापर्यंत \_\_\_\_\_ आहे.

[प्रकाशाच्या वेगाचे मूल्य  $c = 3 \times 10^8 \text{ ms}^{-1}$  घ्या]

**Response Type :** Numeric

**Evaluation Required For SA :** Yes

**Show Word Count :** Yes

**Answers Type :** Equal

**Text Areas :** PlainText

**Possible Answers :**

100

**Question Number :** 28 **Question Id :** 8643516148 **Question Type :** SA

**Correct Marks :** 4 **Wrong Marks :** 0

Consider a water tank as shown in the figure. It's cross-sectional area is  $0.4 \text{ m}^2$ . The tank has an opening B near the bottom whose cross-section area is  $1 \text{ cm}^2$ . A load of  $24 \text{ kg}$  is applied on the water at the top when the height of the water level is  $40 \text{ cm}$  above the bottom, the velocity of water coming out the opening B is  $v \text{ ms}^{-1}$ .

The value of  $v$ , to the nearest integer, is \_\_\_\_\_.

[Take value of  $g$  to be  $10 \text{ ms}^{-2}$ ]

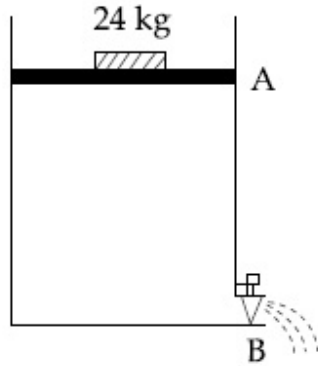

**Response Type :** Numeric

**Evaluation Required For SA :** Yes

**Show Word Count :** Yes

**Answers Type :** Equal

**Text Areas :** PlainText

**Possible Answers :**

100

**Question Number :** 28 **Question Id :** 8643516148 **Question Type :** SA

**Correct Marks :** 4 **Wrong Marks :** 0

आकृतीत दाखविल्याप्रमाणे पाण्याची टाकी विचारात घ्या. तिचे काटछेद क्षेत्रफळ  $0.4 \text{ m}^2$  आहे. त्या टाकीच्या तळाच्या B येथे  $1 \text{ cm}^2$  काटछेदाचे उघडे आहे.  $24 \text{ kg}$  चा भारित (load) पाण्यावर उपयोजित केला जेव्हा पाण्याच्या पातळीची उंची तळापासून  $40 \text{ cm}$  वर आहे, बाहेर येणाऱ्या पाण्याचा B येथून वेग  $v \text{ ms}^{-1}$  आहे.  $v$  चे मूल्य जवळच्या पूर्णांकापर्यंत \_\_\_\_\_ आहे.

[ $g$  चे मूल्य  $10 \text{ ms}^{-2}$  घ्या]

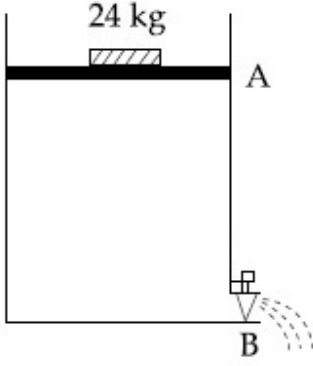

**Response Type :** Numeric

**Evaluation Required For SA :** Yes

**Show Word Count :** Yes

**Answers Type :** Equal

**Text Areas :** PlainText

**Possible Answers :**

100

**Question Number :** 29 **Question Id :** 8643516149 **Question Type :** SA

**Correct Marks :** 4 **Wrong Marks :** 0

A TV transmission tower antenna is at a height of 20 m. Suppose that the receiving antenna is at.

- (i) ground level
- (ii) a height of 5 m.

The increase in antenna range in case (ii) relative to case (i) is  $n\%$ .

The value of  $n$ , to the nearest integer, is \_\_\_\_\_.

**Response Type :** Numeric

**Evaluation Required For SA :** Yes

**Show Word Count :** Yes

**Answers Type :** Equal

**Text Areas :** PlainText

**Possible Answers :**

100

**Question Number :** 29 **Question Id :** 8643516149 **Question Type :** SA

**Correct Marks : 4 Wrong Marks : 0**

दूरदर्शन पारेषण टॉवर अँटेना 20 m उंचीवर आहे. समजा ग्राही अँटेना (i) तळची पातळीवर, (ii) 5 m उंचीवर आहे. अँटेनाच्या पल्लयातील वाढ बाब (ii) सापेक्ष बाब (i)  $n\%$  आहे.

$n$  चे मूल्य जवळच्या पूर्णांकापर्यंत \_\_\_\_\_ आहे.

**Response Type : Numeric**

**Evaluation Required For SA : Yes**

**Show Word Count : Yes**

**Answers Type : Equal**

**Text Areas : PlainText**

**Possible Answers :**

100

**Question Number : 30 Question Id : 8643516150 Question Type : SA**

**Correct Marks : 4 Wrong Marks : 0**

The radius of a sphere is measured to be  $(7.50 \pm 0.85)$  cm. Suppose the percentage error in its volume is  $x$ .

The value of  $x$ , to the nearest  $x$ , is \_\_\_\_\_.

**Response Type : Numeric**

**Evaluation Required For SA : Yes**

**Show Word Count : Yes**

**Answers Type : Equal**

**Text Areas : PlainText**

**Possible Answers :**

100

**Question Number : 30 Question Id : 8643516150 Question Type : SA**

**Correct Marks : 4 Wrong Marks : 0**

गोळ्याची त्रिज्या  $(7.50 \pm 0.85)$  cm मोजली. आकारमानाच्या टक्केवारीतील त्रुटी  $x$  आहे.

$x$  चे मूल्य जवळच्या पूर्णांकापर्यंत \_\_\_\_\_ आहे.

**Response Type : Numeric**

**Evaluation Required For SA : Yes**

**Show Word Count : Yes**

**Answers Type : Equal**

**Text Areas : PlainText**

**Possible Answers :**

100

## Chemistry Section A

<b>Section Id :</b>	864351411
<b>Section Number :</b>	3
<b>Section type :</b>	Online
<b>Mandatory or Optional :</b>	Mandatory
<b>Number of Questions :</b>	20
<b>Number of Questions to be attempted :</b>	20
<b>Section Marks :</b>	80
<b>Mark As Answered Required? :</b>	Yes
<b>Sub-Section Number :</b>	1
<b>Sub-Section Id :</b>	864351411
<b>Question Shuffling Allowed :</b>	Yes

**Question Number : 31 Question Id : 8643516151 Question Type : MCQ Option Shuffling : Yes Is Question Mandatory : No**

**Correct Marks : 4 Wrong Marks : 1**

A hard substance melts at high temperature and is an insulator in both solid and in molten state. This solid is most likely to be a/an :

**Options :**

86435118451. Ionic solid
86435118452. Covalent solid
86435118453. Metallic solid
86435118454. Molecular solid

**Question Number : 31 Question Id : 8643516151 Question Type : MCQ Option Shuffling : Yes Is Question Mandatory : No**

**Correct Marks : 4 Wrong Marks : 1**

एक कठीण पदार्थ जो खुप उच्च तापमानाला वितळतो आणि तो घन तसेच वितळलेल्या अवस्थेतही रोधी आहे. हा घन पदार्थ बहुदा \_\_\_\_\_ आहे.

**Options :**

86435118451. आयनी घन
86435118452. सहसंयुज घन
86435118453. धात्विक घन
86435118454. रेणु घन

**Question Number : 32 Question Id : 8643516152 Question Type : MCQ Option Shuffling : Yes Is**

**Question Mandatory : No**

**Correct Marks : 4 Wrong Marks : 1**

Given below are two statements :

**Statement I :** Bohr's theory accounts for the stability and line spectrum of  $\text{Li}^+$  ion.

**Statement II :** Bohr's theory was unable to explain the splitting of spectral lines in the presence of a magnetic field.

In the light of the above statements, choose the most appropriate answer from the options given below :

**Options :**

86435118455. Both statement I and statement II are true.

86435118456. Both statement I and statement II are false.

86435118457. Statement I is true but statement II is false.

86435118458. Statement I is false but statement II is true.

**Question Number : 32 Question Id : 8643516152 Question Type : MCQ Option Shuffling : Yes Is**

**Question Mandatory : No**

**Correct Marks : 4 Wrong Marks : 1**

खाली दोन विधाने दिलेली आहेत.

**विधान I :**  $\text{Li}^+$  आयनाची स्थिरता आणि रेषापंक्ति बोहरच्या सिद्धांतावरून नोंदता येते.

**विधान II :** चुंबकीय क्षेत्रातील रेषापंक्तिचे दुभंगणे बोहरच्या सिद्धांताने समजवता येत नाही.

वरील विधानांना अनुसरून खालील पर्यायांमधून योग्य उत्तर निवडा.

**Options :**

86435118455. विधान I व विधान II दोन्ही बरोबर आहेत.

86435118456. विधान I व विधान II दोन्ही चूक आहेत.

86435118457. विधान I बरोबर आहे पण विधान II चूक आहे.

86435118458. विधान I चूक आहे पण विधान II बरोबर आहे.

Question Number : 33 Question Id : 8643516153 Question Type : MCQ Option Shuffling : Yes Is

Question Mandatory : No

Correct Marks : 4 Wrong Marks : 1

The charges on the colloidal CdS sol and  $\text{TiO}_2$  sol are, respectively :

Options :

86435118459. positive and positive

86435118460. negative and positive

86435118461. positive and negative

86435118462. negative and negative

Question Number : 33 Question Id : 8643516153 Question Type : MCQ Option Shuffling : Yes Is

Question Mandatory : No

Correct Marks : 4 Wrong Marks : 1

CdS सॉल आणि  $\text{TiO}_2$  सॉल ह्या कलिलांवरचा भार अनुक्रमे \_\_\_\_\_ आहे.

Options :

86435118459. धन आणि धन

86435118460. ऋण आणि धन

86435118461. धन आणि ऋण

86435118462. ऋण आणि ऋण

Question Number : 34 Question Id : 8643516154 Question Type : MCQ Option Shuffling : Yes Is

Question Mandatory : No

Correct Marks : 4 Wrong Marks : 1

The first ionization energy of magnesium is smaller as compared to that of elements X and Y, but higher than that of Z. The elements X, Y and Z, respectively, are :

Options :

86435118463. argon, chlorine and sodium

86435118464. chlorine, lithium and sodium

86435118465. argon, lithium and sodium

86435118466. neon, sodium and chlorine

**Question Number : 34 Question Id : 8643516154 Question Type : MCQ Option Shuffling : Yes Is Question Mandatory : No**

**Correct Marks : 4 Wrong Marks : 1**

मॅग्नेशियमची प्रथम आयनन ऊर्जा हि मूलद्रव्ये X आणि Y पेक्षा कमी पण Z पेक्षा जास्त आहे. मूलद्रव्ये X, Y आणि Z अनुक्रमे \_\_\_\_\_ आहेत.

**Options :**

86435118463. अॅरगॉन, क्लोरिन आणि सोडियम

86435118464. क्लोरिन, लिथियम आणि सोडियम

86435118465. अॅरगॉन, लिथियम आणि सोडियम

86435118466. निऑन, सोडियम आणि क्लोरिन

**Question Number : 35 Question Id : 8643516155 Question Type : MCQ Option Shuffling : Yes Is Question Mandatory : No**

**Correct Marks : 4 Wrong Marks : 1**

**Match List - I with List - II :**

List - I	List - II
(a) Mercury	(i) Vapour phase refining
(b) Copper	(ii) Distillation Refining
(c) Silicon	(iii) Electrolytic Refining
(d) Nickel	(iv) Zone Refining

Choose the most appropriate answer from the option given below :

**Options :**

86435118467. (a)-(ii), (b)-(iii), (c)-(iv), (d)-(i)

86435118468. (a)-(i), (b)-(iv), (c)-(ii), (d)-(iii)

86435118469. (a)-(ii), (b)-(iii), (c)-(i), (d)-(iv)

86435118470. (a)-(ii), (b)-(iv), (c)-(iii), (d)-(i)

Question Number : 35 Question Id : 8643516155 Question Type : MCQ Option Shuffling : Yes Is  
Question Mandatory : No

Correct Marks : 4 Wrong Marks : 1

यादी - I यादी - II बरोबर जुळवा.

यादी - I

यादी - II

- |             |                               |
|-------------|-------------------------------|
| (a) पारा    | (i) बाष्प प्रावस्था परिष्करण  |
| (b) तांबे   | (ii) उर्ध्वपातनी परिष्करण     |
| (c) सिलिकॉन | (iii) विद्युत अपघटनी परिष्करण |
| (d) निकेल   | (iv) झोन परिष्करण             |

खालील पर्यायांमधून योग्य उत्तर निवडा.

Options :

86435118467. (a)-(ii), (b)-(iii), (c)-(iv), (d)-(i)

86435118468. (a)-(i), (b)-(iv), (c)-(ii), (d)-(iii)

86435118469. (a)-(ii), (b)-(iii), (c)-(i), (d)-(iv)

86435118470. (a)-(ii), (b)-(iv), (c)-(iii), (d)-(i)

Question Number : 36 Question Id : 8643516156 Question Type : MCQ Option Shuffling : Yes Is  
Question Mandatory : No

Correct Marks : 4 Wrong Marks : 1

In basic medium,  $H_2O_2$  exhibits which of the following reactions ?

- (A)  $Mn^{2+} \rightarrow Mn^{4+}$   
 (B)  $I_2 \rightarrow I^-$   
 (C)  $PbS \rightarrow PbSO_4$

Choose the most appropriate answer from the options given below :

Options :

86435118471. (A) only

86435118472. (B) only

86435118473. (A), (B) only

86435118474. (A), (C) only

**Question Number : 36 Question Id : 8643516156 Question Type : MCQ Option Shuffling : Yes Is Question Mandatory : No**

**Correct Marks : 4 Wrong Marks : 1**

आम्लारीधर्मी माध्यमात  $H_2O_2$  खालील अभिक्रिया दाखवतो.

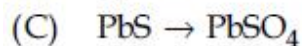
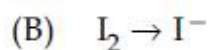
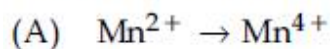

खालील पर्यायांमधून योग्य उत्तर निवडा.

**Options :**

86435118471. (A) फक्त

86435118472. (B) फक्त

86435118473. (A), (B) फक्त

86435118474. (A), (C) फक्त

**Question Number : 37 Question Id : 8643516157 Question Type : MCQ Option Shuffling : Yes Is Question Mandatory : No**

**Correct Marks : 4 Wrong Marks : 1**

**Match List - I with List - II :**

List - I	List - II
(a) Be	(i) treatment of cancer
(b) Mg	(ii) extraction of metals
(c) Ca	(iii) incendiary bombs and signals
(d) Ra	(iv) windows of X-ray tubes
	(v) bearings for motor engines.

Choose the most appropriate answer from the option given below :

**Options :**

86435118475. (a)-(iv), (b)-(iii), (c)-(ii), (d)-(i)

86435118476. (a)-(iii), (b)-(iv), (c)-(ii), (d)-(v)

86435118477. (a)-(iv), (b)-(iii), (c)-(i), (d)-(ii)

86435118478. (a)-(iii), (b)-(iv), (c)-(v), (d)-(ii)

**Question Number : 37 Question Id : 8643516157 Question Type : MCQ Option Shuffling : Yes Is Question Mandatory : No**

**Correct Marks : 4 Wrong Marks : 1**

यादी - I यादी - II बरोबर जुळवा.

यादी - I	यादी - II
(a) Be	(i) कॅन्सरच्या उपचारात
(b) Mg	(ii) धातुंच्या निष्कर्षणात
(c) Ca	(iii) दहनकारी बॉम्ब आणि संकेत मध्ये
(d) Ra	(iv) X-रे नळीच्या खिडक्यांसाठी
	(v) गाडीच्या इंजिनमधील बेअरिंगसाठी

खालील पर्यायांमधून योग्य उत्तर निवडा.

**Options :**

86435118475. (a)-(iv), (b)-(iii), (c)-(ii), (d)-(i)

86435118476. (a)-(iii), (b)-(iv), (c)-(ii), (d)-(v)

86435118477. (a)-(iv), (b)-(iii), (c)-(i), (d)-(ii)

86435118478. (a)-(iii), (b)-(iv), (c)-(v), (d)-(ii)

**Question Number : 38 Question Id : 8643516158 Question Type : MCQ Option Shuffling : Yes Is Question Mandatory : No**

**Correct Marks : 4 Wrong Marks : 1**

The oxidation states of nitrogen in NO, NO<sub>2</sub>, N<sub>2</sub>O and NO<sub>3</sub><sup>-</sup> are in the order of :

**Options :**

86435118479. NO > NO<sub>2</sub> > N<sub>2</sub>O > NO<sub>3</sub><sup>-</sup>

86435118480. N<sub>2</sub>O > NO<sub>2</sub> > NO > NO<sub>3</sub><sup>-</sup>

86435118481.  $\text{NO}_2 > \text{NO}_3^- > \text{NO} > \text{N}_2\text{O}$

86435118482.  $\text{NO}_3^- > \text{NO}_2 > \text{NO} > \text{N}_2\text{O}$

**Question Number : 38 Question Id : 8643516158 Question Type : MCQ Option Shuffling : Yes Is Question Mandatory : No**

**Correct Marks : 4 Wrong Marks : 1**

NO, NO<sub>2</sub>, N<sub>2</sub>O आणि NO<sub>3</sub><sup>-</sup> मधील नायट्रोजनच्या ऑक्सिडन स्थिती \_\_\_\_\_ क्रमाने आहेत.

**Options :**

86435118479.  $\text{NO} > \text{NO}_2 > \text{N}_2\text{O} > \text{NO}_3^-$

86435118480.  $\text{N}_2\text{O} > \text{NO}_2 > \text{NO} > \text{NO}_3^-$

86435118481.  $\text{NO}_2 > \text{NO}_3^- > \text{NO} > \text{N}_2\text{O}$

86435118482.  $\text{NO}_3^- > \text{NO}_2 > \text{NO} > \text{N}_2\text{O}$

**Question Number : 39 Question Id : 8643516159 Question Type : MCQ Option Shuffling : Yes Is Question Mandatory : No**

**Correct Marks : 4 Wrong Marks : 1**

The oxide that shows magnetic property is :

**Options :**

86435118483.  $\text{SiO}_2$

86435118484.  $\text{Mn}_3\text{O}_4$

86435118485.  $\text{MgO}$

86435118486.  $\text{Na}_2\text{O}$

**Question Number : 39 Question Id : 8643516159 Question Type : MCQ Option Shuffling : Yes Is Question Mandatory : No**

**Correct Marks : 4 Wrong Marks : 1**

चुंबकीय गुणधर्म दाखवणारे ऑक्साइड \_\_\_\_\_ आहे.

**Options :**

86435118483.  $\text{SiO}_2$

86435118484.  $\text{Mn}_3\text{O}_4$

86435118485.  $\text{MgO}$

86435118486.  $\text{Na}_2\text{O}$

**Question Number : 40 Question Id : 8643516160 Question Type : MCQ Option Shuffling : Yes Is Question Mandatory : No**

**Correct Marks : 4 Wrong Marks : 1**

The secondary valency and the number of hydrogen bonded water molecule(s) in  $\text{CuSO}_4 \cdot 5\text{H}_2\text{O}$ , respectively, are :

**Options :**

86435118487. 4 and 1

86435118488. 6 and 4

86435118489. 5 and 1

86435118490. 6 and 5

**Question Number : 40 Question Id : 8643516160 Question Type : MCQ Option Shuffling : Yes Is Question Mandatory : No**

**Correct Marks : 4 Wrong Marks : 1**

$\text{CuSO}_4 \cdot 5\text{H}_2\text{O}$  मधील द्वितीयक संयुजा आणि हायड्रोजन बंधनातील पाण्याच्या रेणूंची संख्या अनुक्रमे \_\_\_\_\_ आहे.

**Options :**

86435118487. 4 आणि 1

86435118488. 6 आणि 4

86435118489. 5 आणि 1

86435118490. 6 आणि 5

**Question Number : 41 Question Id : 8643516161 Question Type : MCQ Option Shuffling : Yes Is**

**Question Mandatory : No**

**Correct Marks : 4 Wrong Marks : 1**

Given below are two statements :

**Statement I :** Non-biodegradable wastes are generated by the thermal power plants.

**Statement II :** Bio-degradable detergents leads to eutrophication.

In the light of the above statements, choose the most appropriate answer from the options given below :

**Options :**

86435118491. Both statement I and statement II are true.

86435118492. Both statement I and statement II are false.

86435118493. Statement I is true but statement II is false.

86435118494. Statement I is false but statement II is true.

**Question Number : 41 Question Id : 8643516161 Question Type : MCQ Option Shuffling : Yes Is**

**Question Mandatory : No**

**Correct Marks : 4 Wrong Marks : 1**

खाली दोन विधाने दिलेली आहेत.

**विधान I :** औष्णिक विद्युत केंद्रात जैवअपघटनीय नसलेला कचरा निर्माण होतो.

**विधान II :** जैवअपघटनीय निर्मलकामुळे युट्रोफिकेशन होते.

वरील विधानांना अनुसरून खालील पर्यायांमधून योग्य उत्तर निवडा.

**Options :**

86435118491. विधान I व विधान II दोन्ही बरोबर आहेत.

86435118492. विधान I व विधान II दोन्ही चूक आहेत.

86435118493. विधान I बरोबर आहे पण विधान II चूक आहे.

विधान I चूक आहे पण विधान II बरोबर आहे.  
86435118494.

**Question Number : 42 Question Id : 8643516162 Question Type : MCQ Option Shuffling : Yes Is Question Mandatory : No**

**Correct Marks : 4 Wrong Marks : 1**

Given below are two statements :

**Statement I :**  $C_2H_5OH$  and  $AgCN$  both can generate nucleophile.

**Statement II :**  $KCN$  and  $AgCN$  both will generate nitrile nucleophile with all reaction conditions.

Choose the most appropriate option :

**Options :**

86435118495. Both statement I and statement II are true.

86435118496. Both statement I and statement II are false.

86435118497. Statement I is true but statement II is false.

86435118498. Statement I is false but statement II is true.

**Question Number : 42 Question Id : 8643516162 Question Type : MCQ Option Shuffling : Yes Is Question Mandatory : No**

**Correct Marks : 4 Wrong Marks : 1**

खाली दोन विधाने दिलेली आहेत.

**विधान I :**  $C_2H_5OH$  आणि  $AgCN$  दोन्ही केंद्राकर्षी तयार करू शकतात.

**विधान II :**  $KCN$  आणि  $AgCN$  दोन्ही सर्व अभिक्रियांच्या परिस्थितीत नाइट्राइल केंद्राकर्षी तयार करतात.

योग्य पर्याय निवडा.

**Options :**

86435118495. विधान I व विधान II दोन्ही बरोबर आहेत.

86435118496. विधान I व विधान II दोन्ही चूक आहेत.

86435118497. विधान I बरोबर आहे पण विधान II चूक आहे.

86435118498. विधान I चूक आहे पण विधान II बरोबर आहे.

Question Number : 43 Question Id : 8643516163 Question Type : MCQ Option Shuffling : Yes Is

Question Mandatory : No

Correct Marks : 4 Wrong Marks : 1

In the following molecule,

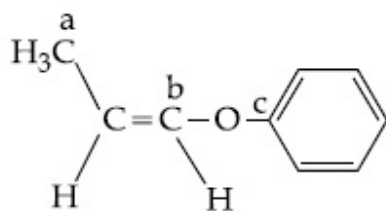

Hybridisation of Carbon a, b and c respectively are :

Options :

86435118499.  $sp^3, sp^2, sp^2$

86435118500.  $sp^3, sp^2, sp$

86435118501.  $sp^3, sp, sp$

86435118502.  $sp^3, sp, sp^2$

Question Number : 43 Question Id : 8643516163 Question Type : MCQ Option Shuffling : Yes Is

Question Mandatory : No

Correct Marks : 4 Wrong Marks : 1

खालील संयुगात

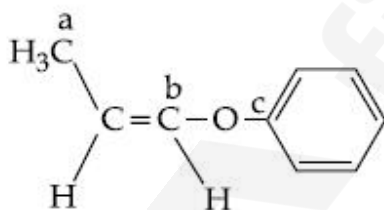

a, b आणि c ह्या कार्बनचे संकरण अनुक्रमे \_\_\_\_\_ आहे.

Options :

86435118499.  $sp^3, sp^2, sp^2$

86435118500.  $sp^3, sp^2, sp$

86435118501.  $sp^3, sp, sp$

86435118502.  $sp^3, sp, sp^2$

Question Number : 44 Question Id : 8643516164 Question Type : MCQ Option Shuffling : Yes Is

Question Mandatory : No

Correct Marks : 4 Wrong Marks : 1

Main Products formed during a reaction of 1-methoxy naphthalene with hydroiodic acid are :

Options :

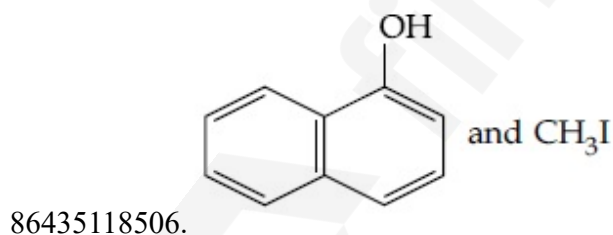
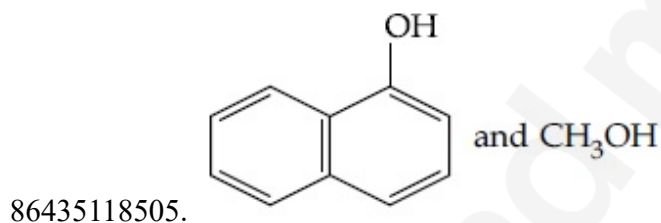
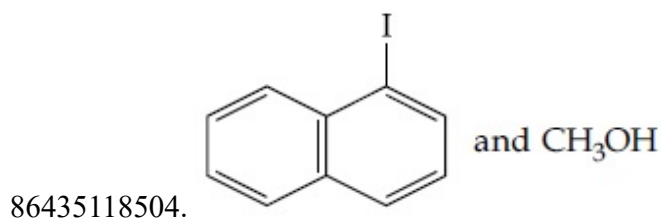
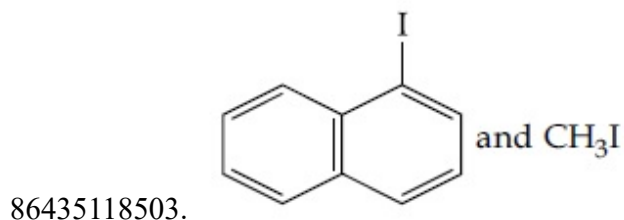

Question Number : 44 Question Id : 8643516164 Question Type : MCQ Option Shuffling : Yes Is

Question Mandatory : No

Correct Marks : 4 Wrong Marks : 1

1-मिथॉक्सी नॅफ्थॅलीन ची हायड्रोआयोडीक आम्लासोबत अभिक्रिया करता प्रमुख उत्पाद \_\_\_\_\_ आहेत.

Options :

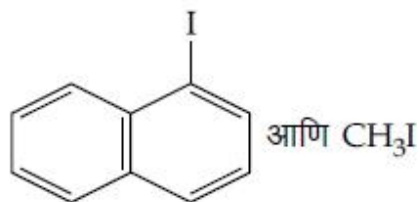

86435118503.

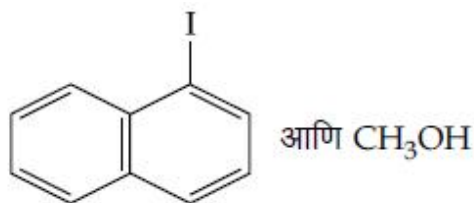

86435118504.

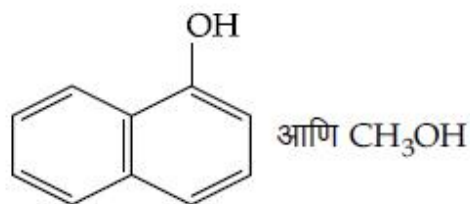

86435118505.

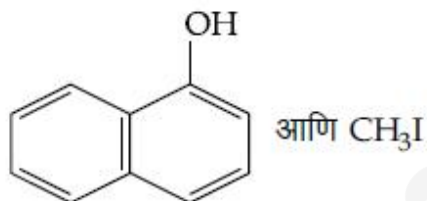

86435118506.

Question Number : 45 Question Id : 8643516165 Question Type : MCQ Option Shuffling : Yes Is

Question Mandatory : No

Correct Marks : 4 Wrong Marks : 1

In the reaction of hypobromite with amide, the carbonyl carbon is lost as :

Options :

86435118507.  $\text{CO}$ 86435118508.  $\text{CO}_2$ 86435118509.  $\text{CO}_3^{2-}$ 86435118510.  $\text{HCO}_3^-$ 

Question Number : 45 Question Id : 8643516165 Question Type : MCQ Option Shuffling : Yes Is

Question Mandatory : No

Correct Marks : 4 Wrong Marks : 1

अमाइडच्या हायपोब्रोमाइट सोबत अभिक्रियेत घटलेला कार्बोनिल कार्बन \_\_\_\_\_ असा घटतो.

Options :

86435118507.  $\text{CO}$

86435118508.  $\text{CO}_2$

86435118509.  $\text{CO}_3^{2-}$

86435118510.  $\text{HCO}_3^-$

Question Number : 46 Question Id : 8643516166 Question Type : MCQ Option Shuffling : Yes Is

Question Mandatory : No

Correct Marks : 4 Wrong Marks : 1

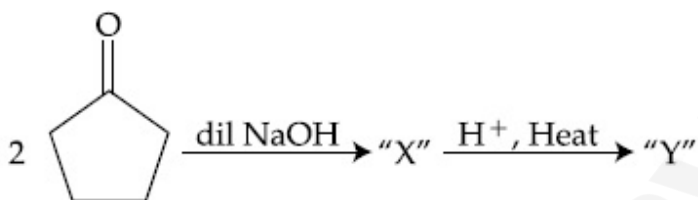

Consider the above reaction, the product 'X' and 'Y' respectively are :

Options :

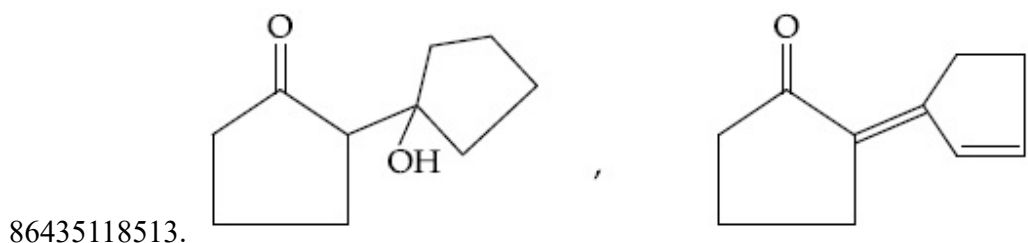
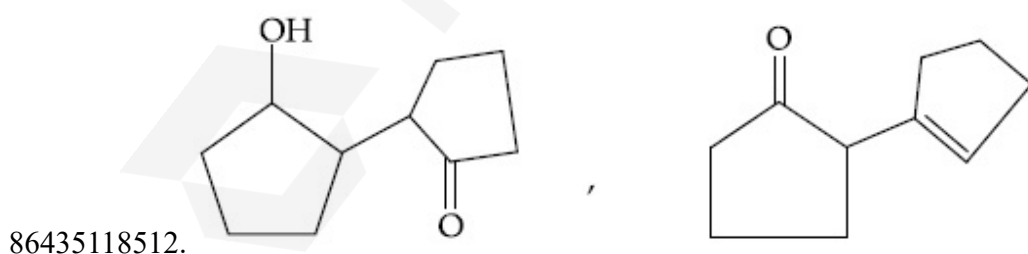
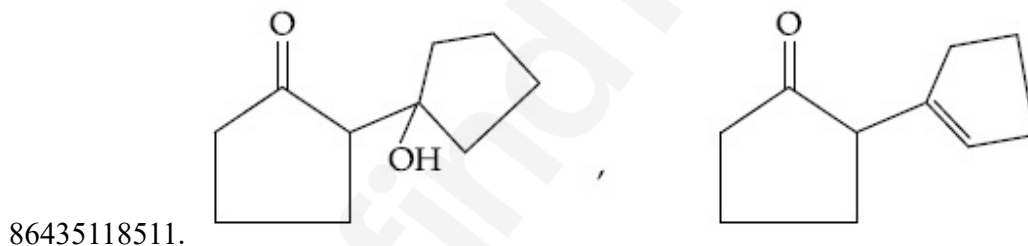

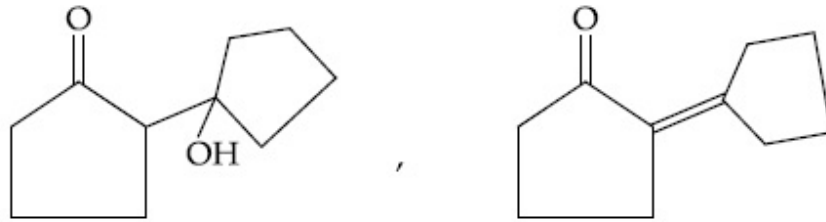

86435118514.

Question Number : 46 Question Id : 8643516166 Question Type : MCQ Option Shuffling : Yes Is Question Mandatory : No

Correct Marks : 4 Wrong Marks : 1

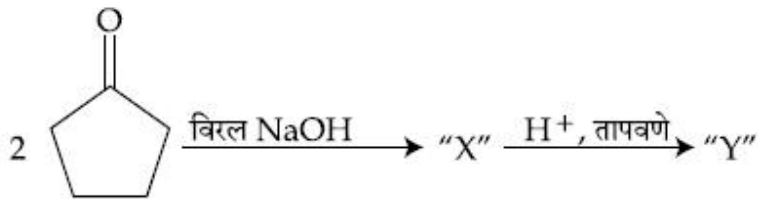

वरील अभिक्रिया लक्षात घ्या, उत्पाद 'X' आणि 'Y' अनुक्रमे \_\_\_\_\_ आहेत.

Options :



86435118511.



86435118512.

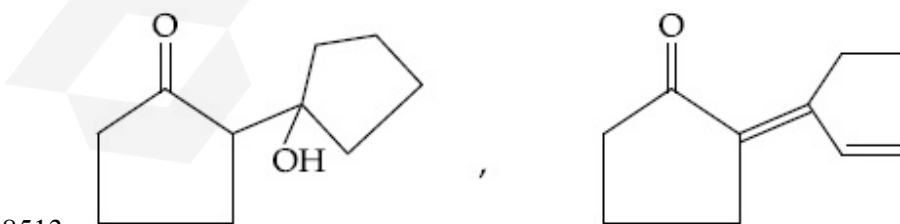

86435118513.

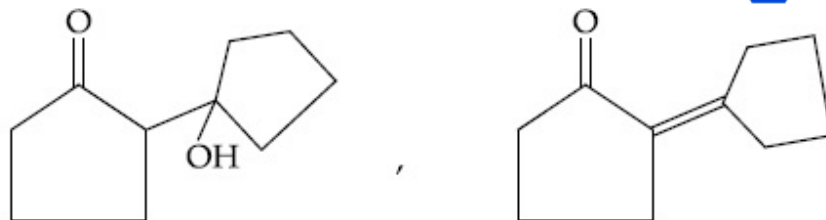

86435118514.

**Question Number : 47 Question Id : 8643516167 Question Type : MCQ Option Shuffling : Yes Is Question Mandatory : No**

**Correct Marks : 4 Wrong Marks : 1**

An organic compound "A" on treatment with benzene sulphonyl chloride gives compound B. B is soluble in dil. NaOH solution. Compound A is :

**Options :**

86435118515.  $C_6H_5 - CH_2 NH CH_3$

86435118516.  $C_6H_5 - N - (CH_3)_2$

86435118517.  $C_6H_5 - NHCH_2CH_3$

86435118518.  $C_6H_5 - \underset{\substack{| \\ CH_3}}{CH} - NH_2$

**Question Number : 47 Question Id : 8643516167 Question Type : MCQ Option Shuffling : Yes Is Question Mandatory : No**

**Correct Marks : 4 Wrong Marks : 1**

बेंझिन सल्फोनील क्लोराइडच्या एका कार्बनी "A" संयुगासोबत अभिक्रियेत संयुग B तयार होते. B हे संयुग NaOH च्या द्रावणात विरघळते कार्बनी संयुग A \_\_\_\_\_ आहे.

**Options :**

86435118515.  $C_6H_5 - CH_2 NH CH_3$

86435118516.  $C_6H_5 - N - (CH_3)_2$

86435118517.  $C_6H_5 - NHCH_2CH_3$

86435118518.  $C_6H_5 - \underset{\substack{| \\ CH_3}}{CH} - NH_2$

Question Number : 48 Question Id : 8643516168 Question Type : MCQ Option Shuffling : Yes Is

Question Mandatory : No

Correct Marks : 4 Wrong Marks : 1

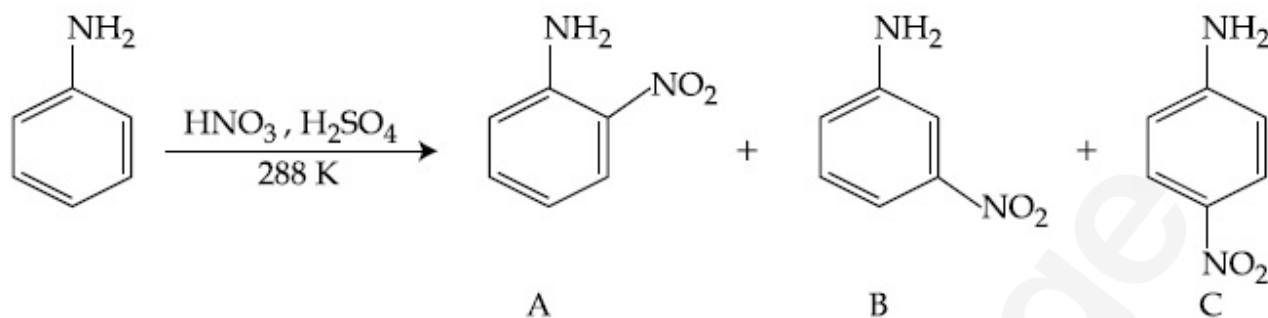

Consider the given reaction, percentage yield of :

Options :

86435118519. A > C > B

86435118520. C > A > B

86435118521. B > C > A

86435118522. C > B > A

Question Number : 48 Question Id : 8643516168 Question Type : MCQ Option Shuffling : Yes Is

Question Mandatory : No

Correct Marks : 4 Wrong Marks : 1

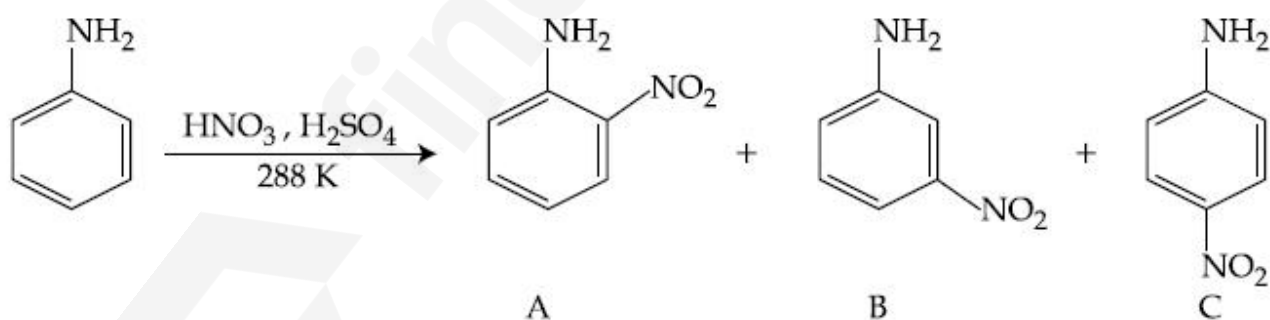

अभिक्रिया लक्षात घ्या, टक्का प्राप्ती \_\_\_\_\_.

Options :

86435118519. A > C > B

86435118520. C > A > B

86435118521. B > C > A

86435118522.  $C > B > A$

**Question Number : 49 Question Id : 8643516169 Question Type : MCQ Option Shuffling : Yes Is Question Mandatory : No**

**Correct Marks : 4 Wrong Marks : 1**

**Match List - I with List - II :**

List - I (Class of Chemicals)	List - II (Example)
(a) Antifertility drug	(i) Meprobamate
(b) Antibiotic	(ii) Alitame
(c) Tranquilizer	(iii) Norethindrone
(d) Artificial Sweetener	(iv) Salvarsan

**Choose the most appropriate match :**

**Options :**

86435118523. (a)-(iv), (b)-(iii), (c)-(ii), (d)-(i)

86435118524. (a)-(ii), (b)-(iii), (c)-(iv), (d)-(i)

86435118525. (a)-(iii), (b)-(iv), (c)-(i), (d)-(ii)

86435118526. (a)-(ii), (b)-(iv), (c)-(i), (d)-(iii)

**Question Number : 49 Question Id : 8643516169 Question Type : MCQ Option Shuffling : Yes Is Question Mandatory : No**

**Correct Marks : 4 Wrong Marks : 1**

यादी - I यादी - II बरोबर जुळवा.

यादी - I	यादी - II
(रसायनांचा प्रकार)	(उदाहरण)
(a) फलनक्षमता नसणारे औषध	(i) मेप्रोबामेट
(b) प्रतिजैविक	(ii) अेलटेम
(c) प्रशांतक	(iii) नॉरएथिनड्रोन
(d) कृत्रिम माधुर्यकारक	(iv) सालव्हारसन

योग्य जोडीचा पर्याय निवडा.

**Options :**

86435118523. (a)-(iv), (b)-(iii), (c)-(ii), (d)-(i)

86435118524. (a)-(ii), (b)-(iii), (c)-(iv), (d)-(i)

86435118525. (a)-(iii), (b)-(iv), (c)-(i), (d)-(ii)

86435118526. (a)-(ii), (b)-(iv), (c)-(i), (d)-(iii)

**Question Number : 50 Question Id : 8643516170 Question Type : MCQ Option Shuffling : Yes Is Question Mandatory : No**

**Correct Marks : 4 Wrong Marks : 1**

Deficiency of vitamin K causes :

**Options :**

86435118527. Increase in blood clotting time

86435118528. Decrease in blood clotting time

86435118529. Cheilosis

86435118530. Increase in fragility of RBC's

**Question Number : 50 Question Id : 8643516170 Question Type : MCQ Option Shuffling : Yes Is Question Mandatory : No**

**Correct Marks : 4 Wrong Marks : 1**

K जीवनसत्वाच्या कमतरतेमुळे \_\_\_\_\_ होते.

**Options :**

86435118527. रक्त गोठण्याला जास्त वेळ लागतो

86435118528. रक्त गोठण्याला कमी वेळ लागतो

86435118529. किलिऑसिस

86435118530. RBC च्या मोडण्यात भर पडते.

**Chemistry Section B**

<b>Section Id :</b>	864351412
<b>Section Number :</b>	4
<b>Section type :</b>	Online
<b>Mandatory or Optional :</b>	Mandatory
<b>Number of Questions :</b>	10
<b>Number of Questions to be attempted :</b>	5
<b>Section Marks :</b>	20
<b>Mark As Answered Required? :</b>	Yes
<b>Sub-Section Number :</b>	1
<b>Sub-Section Id :</b>	864351412
<b>Question Shuffling Allowed :</b>	Yes

**Question Number : 51 Question Id : 8643516171 Question Type : SA**

**Correct Marks : 4 Wrong Marks : 0**

10.0 mL of  $\text{Na}_2\text{CO}_3$  solution is titrated against 0.2 M HCl solution. The following titre values were obtained in 5 readings :

4.8 mL, 4.9 mL, 5.0 mL, 5.0 mL and 5.0 mL.

Based on these readings, and convention of titrimetric estimation the concentration of  $\text{Na}_2\text{CO}_3$  solution is \_\_\_\_\_ mM.

(Round off to the Nearest Integer).

**Response Type : Numeric**

**Evaluation Required For SA : Yes**

**Show Word Count : Yes**

**Answers Type : Equal**

**Text Areas : PlainText**

**Possible Answers :**

100

**Question Number : 51 Question Id : 8643516171 Question Type : SA**

**Correct Marks : 4 Wrong Marks : 0**

10.0 mL  $\text{Na}_2\text{CO}_3$  द्रावणाचे 0.2 M HCl द्रावणाबरोबर अनुमापन केले. 5 नोंदींमध्ये अनुमापन मूल्ये आढळली :

4.8 mL, 4.9 mL, 5.0 mL, 5.0 mL आणि 5.0 mL.

वरील नोंदीनुसार आणि अनुमापन निर्धारणाच्या प्रचलित पद्धतीनुसार  $\text{Na}_2\text{CO}_3$  द्रावणाची संहती \_\_\_\_\_ mM आहे. (जवळच्या पूर्णांकात)

**Response Type : Numeric**

**Evaluation Required For SA : Yes**

**Show Word Count : Yes**

**Answers Type : Equal**

**Text Areas : PlainText**

**Possible Answers :**

100

**Question Number : 52 Question Id : 8643516172 Question Type : SA**

**Correct Marks : 4 Wrong Marks : 0**

The number of species below that have two lone pairs of electrons in their central atom is \_\_\_\_\_. (Round off to the Nearest Integer).

$\text{SF}_4$ ,  $\text{BF}_4^-$ ,  $\text{ClF}_3$ ,  $\text{AsF}_3$ ,  $\text{PCl}_5$ ,  $\text{BrF}_5$ ,  $\text{XeF}_4$ ,  $\text{SF}_6$

**Response Type : Numeric**

**Evaluation Required For SA : Yes**

**Show Word Count : Yes**

**Answers Type : Equal**

**Text Areas : PlainText**

**Possible Answers :**

100

**Question Number : 52 Question Id : 8643516172 Question Type : SA**

**Correct Marks : 4 Wrong Marks : 0**

मध्यवर्ती अणुवर दोन विविक्त इलेक्ट्रॉन युग्म असलेल्या खालीलपैकी जातींची संख्या \_\_\_\_\_ आहे.

$\text{SF}_4$ ,  $\text{BF}_4^-$ ,  $\text{ClF}_3$ ,  $\text{AsF}_3$ ,  $\text{PCl}_5$ ,  $\text{BrF}_5$ ,  $\text{XeF}_4$ ,  $\text{SF}_6$

(जवळच्या पूर्णांकात)

**Response Type : Numeric**

**Evaluation Required For SA : Yes**

**Show Word Count : Yes**

**Answers Type : Equal**

**Text Areas :** PlainText

**Possible Answers :**

100

**Question Number : 53 Question Id : 8643516173 Question Type : SA**

**Correct Marks : 4 Wrong Marks : 0**

The gas phase reaction

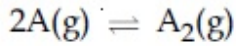

at 400 K has  $\Delta G^\circ = +25.2 \text{ kJ mol}^{-1}$ .

The equilibrium constant  $K_C$  for this reaction is \_\_\_\_\_  $\times 10^{-2}$ . (Round off to the Nearest Integer).

[Use :  $R = 8.3 \text{ J mol}^{-1} \text{ K}^{-1}$ ,  $\ln 10 = 2.3$

$$\log_{10} 2 = 0.30, 1 \text{ atm} = 1 \text{ bar}]$$

[antilog  $(-0.3) = 0.501]$

**Response Type :** Numeric

**Evaluation Required For SA :** Yes

**Show Word Count :** Yes

**Answers Type :** Equal

**Text Areas :** PlainText

**Possible Answers :**

100

**Question Number : 53 Question Id : 8643516173 Question Type : SA**

**Correct Marks : 4 Wrong Marks : 0**

वायु प्रावस्थेतील अभिक्रियेसाठी



$\Delta G^\circ = +25.2 \text{ kJ mol}^{-1}$  400 K तापमानाला ह्या अभिक्रियेसाठी समतोल स्थिरांक  $K_C$  \_\_\_\_\_  $\times 10^{-2}$  आहे. (जवळच्या पूर्णांकात)

[वापरा :  $R = 8.3 \text{ J mol}^{-1} \text{ K}^{-1}$ ,  $\ln 10 = 2.3$

$$\log_{10} 2 = 0.30, 1 \text{ atm} = 1 \text{ bar}]$$

[antilog  $(-0.3) = 0.501]$

**Response Type :** Numeric

**Evaluation Required For SA :** Yes

**Show Word Count :** Yes

**Answers Type :** Equal

**Text Areas :** PlainText

**Possible Answers :**

100

Question Number : 54 Question Id : 8643516174 Question Type : SA

Correct Marks : 4 Wrong Marks : 0

A solute A dimerizes in water. The boiling point of a 2 molal solution of A is  $100.52^{\circ}\text{C}$ . The percentage association of A is \_\_\_\_\_. (Round off to the Nearest Integer).

[Use :  $K_b$  for water =  $0.52 \text{ K kg mol}^{-1}$

Boiling point of water =  $100^{\circ}\text{C}$ ]

Response Type : Numeric

Evaluation Required For SA : Yes

Show Word Count : Yes

Answers Type : Equal

Text Areas : PlainText

Possible Answers :

100

Question Number : 54 Question Id : 8643516174 Question Type : SA

Correct Marks : 4 Wrong Marks : 0

एका द्राव्याचे A पाण्यात द्विवारिकन होते. 2 मोलल A च्या द्रावणाचा उत्कलनांक  $100.52^{\circ}\text{C}$  आहे. A चा टक्का सहचरणांक \_\_\_\_\_ आहे. (जवळच्या पूर्णाकात)

(वापरा :  $K_b$  पाण्यासाठी =  $0.52 \text{ K kg mol}^{-1}$

पाण्याचा उत्कलनांक =  $100^{\circ}\text{C}$ )

Response Type : Numeric

Evaluation Required For SA : Yes

Show Word Count : Yes

Answers Type : Equal

Text Areas : PlainText

Possible Answers :

100

Question Number : 55 Question Id : 8643516175 Question Type : SA

Correct Marks : 4 Wrong Marks : 0

The solubility of  $\text{CdSO}_4$  in water is  $8.0 \times 10^{-4} \text{ mol L}^{-1}$ . Its solubility in  $0.01 \text{ M H}_2\text{SO}_4$  solution is \_\_\_\_\_  $\times 10^{-6} \text{ mol L}^{-1}$ . (Round off to the Nearest Integer).

(Assume that solubility is much less than  $0.01 \text{ M}$ )

Response Type : Numeric

Evaluation Required For SA : Yes

Show Word Count : Yes

Answers Type : Equal

Text Areas : PlainText

Possible Answers :

100

**Question Number : 55 Question Id : 8643516175 Question Type : SA**

**Correct Marks : 4 Wrong Marks : 0**

$\text{CdSO}_4$  ची पाण्यातील द्रावणीयता  $8.0 \times 10^{-4} \text{ mol L}^{-1}$  आहे. त्याची  $0.01 \text{ M H}_2\text{SO}_4$  द्रावणातील द्रावणीयता \_\_\_\_\_  $\times 10^{-6} \text{ mol L}^{-1}$  आहे. (जवळच्या पूर्णांकात)

(द्रावणीयता ही  $0.01 \text{ M}$  पेक्षा खूपच कमी आहे असे समजा)

**Response Type : Numeric**

**Evaluation Required For SA : Yes**

**Show Word Count : Yes**

**Answers Type : Equal**

**Text Areas : PlainText**

**Possible Answers :**

100

**Question Number : 56 Question Id : 8643516176 Question Type : SA**

**Correct Marks : 4 Wrong Marks : 0**

The molar conductivities at infinite dilution of barium chloride, sulphuric acid and hydrochloric acid are 280, 860 and 426  $\text{S cm}^2 \text{ mol}^{-1}$  respectively. The molar conductivity at infinite dilution of barium sulphate is \_\_\_\_\_  $\text{S cm}^2 \text{ mol}^{-1}$ . (Round off to the Nearest Integer).

**Response Type : Numeric**

**Evaluation Required For SA : Yes**

**Show Word Count : Yes**

**Answers Type : Equal**

**Text Areas : PlainText**

**Possible Answers :**

100

**Question Number : 56 Question Id : 8643516176 Question Type : SA**

**Correct Marks : 4 Wrong Marks : 0**

बेरिअम क्लोराइड, सल्फ्युरिक आम्ल आणि हायड्रोक्लोरिक आम्लाच्या अमर्याद विरलतेला ग्रॅमरेण्वीय वाहकता अनुक्रमे 280, 860 आणि  $426 \text{ S cm}^2 \text{ mol}^{-1}$  आहेत. बेरिअम सल्फेटची अमर्याद विरलतेला ग्रॅमरेण्वीय वाहकता \_\_\_\_\_  $\text{S cm}^2 \text{ mol}^{-1}$  असेल. (जवळच्या पूर्णांकात)

**Response Type : Numeric**

**Evaluation Required For SA : Yes**

**Show Word Count : Yes**

**Answers Type : Equal**

**Text Areas : PlainText**

**Possible Answers :**

100

**Question Number : 57 Question Id : 8643516177 Question Type : SA**

**Correct Marks : 4 Wrong Marks : 0**

A reaction has a half life of 1 min. The time required for 99.9% completion of the reaction is \_\_\_\_\_ min. (Round off to the Nearest Integer).

[Use :  $\ln 2 = 0.69$ ;  $\ln 10 = 2.3$ ]

**Response Type : Numeric**

**Evaluation Required For SA : Yes**

**Show Word Count : Yes**

**Answers Type : Equal**

**Text Areas : PlainText**

**Possible Answers :**

100

**Question Number : 57 Question Id : 8643516177 Question Type : SA**

**Correct Marks : 4 Wrong Marks : 0**

एका अभिक्रियेसाठी अर्धायु काल 1 min आहे. 99.9% अभिक्रियेच्या पूर्णत्वासाठी लागणारा वेळ \_\_\_\_\_ मिनिटे आहे. (जवळच्या पूर्णांकात)

[वापरा :  $\ln 2 = 0.69$ ;  $\ln 10 = 2.3$ ]

**Response Type : Numeric**

**Evaluation Required For SA : Yes**

**Show Word Count : Yes**

**Answers Type : Equal**

**Text Areas : PlainText**

**Possible Answers :**

100

**Question Number : 58 Question Id : 8643516178 Question Type : SA**

**Correct Marks : 4 Wrong Marks : 0**

A xenon compound 'A' upon partial hydrolysis gives  $\text{XeO}_2\text{F}_2$ . The number of lone pair of electrons present in compound A is \_\_\_\_\_. (Round off to the Nearest Integer)

**Response Type : Numeric**

**Evaluation Required For SA : Yes**

**Show Word Count : Yes**

**Answers Type : Equal**

**Text Areas : PlainText**

**Possible Answers :**

100

Question Number : 58 Question Id : 8643516178 Question Type : SA

Correct Marks : 4 Wrong Marks : 0

$\text{XeO}_2\text{F}_2$  च्या आंशिक जलीय अपघटनाने झेनॉन चे एक संयुग 'A' तयार होते. संयुग A मधील विविक्त इलेक्ट्रॉन युग्मांची संख्या \_\_\_\_\_ आहे. (जवळच्या पूर्णांकात)

Response Type : Numeric

Evaluation Required For SA : Yes

Show Word Count : Yes

Answers Type : Equal

Text Areas : PlainText

Possible Answers :

100

Question Number : 59 Question Id : 8643516179 Question Type : SA

Correct Marks : 4 Wrong Marks : 0

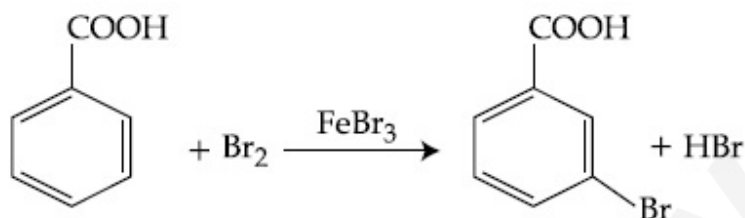

Consider the above reaction where 6.1 g of Benzoic acid is used to get 7.8 g of m-bromo benzoic acid. The percentage yield of the product is \_\_\_\_\_.

(Round off to the Nearest Integer).

[Given : Atomic masses : C : 12.0 u, H : 1.0 u, O : 16.0 u, Br : 80.0 u]

Response Type : Numeric

Evaluation Required For SA : Yes

Show Word Count : Yes

Answers Type : Equal

Text Areas : PlainText

Possible Answers :

100

Question Number : 59 Question Id : 8643516179 Question Type : SA

Correct Marks : 4 Wrong Marks : 0

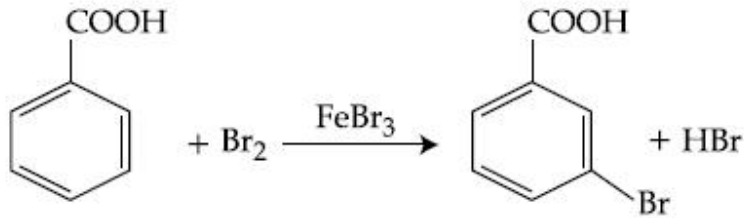

वरील अभिक्रिया लक्षात घ्या जेथे 6.1 ग्रॅ. बेंझॉइक आम्ल वापरले असता 7.8 ग्रॅ. m-ब्रोमोबेंझॉइक आम्ल मिळते. उत्पादाचा टक्का प्राप्ती \_\_\_\_\_ आहे.

(जवळच्या पूर्णांकात)

(दिलेल आहे : अणु वस्तुमान : C : 12.0 u, H : 1.0 u, O : 16.0 u, Br ; 80.0 u)

**Response Type :** Numeric

**Evaluation Required For SA :** Yes

**Show Word Count :** Yes

**Answers Type :** Equal

**Text Areas :** PlainText

**Possible Answers :**

100

**Question Number :** 60 **Question Id :** 8643516180 **Question Type :** SA

**Correct Marks :** 4 **Wrong Marks :** 0

In Tollen's test for aldehyde, the overall number of electron(s) transferred to the Tollen's reagent formula  $[\text{Ag}(\text{NH}_3)_2]^+$  per aldehyde group to form silver mirror is \_\_\_\_\_. (Round off to the Nearest Integer).

**Response Type :** Numeric

**Evaluation Required For SA :** Yes

**Show Word Count :** Yes

**Answers Type :** Equal

**Text Areas :** PlainText

**Possible Answers :**

100

**Question Number :** 60 **Question Id :** 8643516180 **Question Type :** SA

**Correct Marks :** 4 **Wrong Marks :** 0

अल्डिहाइडच्या टोलन्सच्या चाचणीत, टोलन्सच्या अभिक्रियाकारकास  $[\text{Ag}(\text{NH}_3)_2]^+$  प्रति अल्डिहाइड गटाच्या दिलेल्या एकूण इलेक्ट्रॉन्सची संख्या ज्यामुळे चांदीचा आरसा तयार होतो ती \_\_\_\_\_ आहे. (जवळच्या पूर्णांकात)

**Response Type :** Numeric

**Evaluation Required For SA :** Yes

**Show Word Count :** Yes

Answers Type : Equal

Text Areas : PlainText

Possible Answers :

100

## Mathematics Section A

Section Id :	864351413
Section Number :	5
Section type :	Online
Mandatory or Optional :	Mandatory
Number of Questions :	20
Number of Questions to be attempted :	20
Section Marks :	80
Mark As Answered Required? :	Yes
Sub-Section Number :	1
Sub-Section Id :	864351413
Question Shuffling Allowed :	Yes

Question Number : 61 Question Id : 8643516181 Question Type : MCQ Option Shuffling : Yes Is

Question Mandatory : No

Correct Marks : 4 Wrong Marks : 1

If  $15\sin^4\alpha + 10\cos^4\alpha = 6$ , for some  $\alpha \in \mathbb{R}$ , then the value of  $27\sec^6\alpha + 8\operatorname{cosec}^6\alpha$  is equal to :

Options :

86435118541. 500

86435118542. 400

86435118543. 350

86435118544. 250

Question Number : 61 Question Id : 8643516181 Question Type : MCQ Option Shuffling : Yes Is

Question Mandatory : No

Correct Marks : 4 Wrong Marks : 1

जर  $15\sin^4\alpha + 10\cos^4\alpha = 6$ , काही  $\alpha \in \mathbb{R}$  साठी, तर  $27\sec^6\alpha + 8\operatorname{cosec}^6\alpha$  चे मूल्य बरोबर \_\_\_\_\_

आहे.

Options :

86435118541. 500

86435118542. 400

86435118543. 350

86435118544. 250

**Question Number : 62 Question Id : 8643516182 Question Type : MCQ Option Shuffling : Yes Is Question Mandatory : No**

**Correct Marks : 4 Wrong Marks : 1**

If P and Q are two statements, then which of the following compound statement is a tautology ?

**Options :**

86435118545.  $((P \Rightarrow Q) \wedge \sim Q) \Rightarrow P$ 86435118546.  $((P \Rightarrow Q) \wedge \sim Q) \Rightarrow Q$ 86435118547.  $((P \Rightarrow Q) \wedge \sim Q) \Rightarrow \sim P$ 86435118548.  $((P \Rightarrow Q) \wedge \sim Q) \Rightarrow (P \wedge Q)$ 

**Question Number : 62 Question Id : 8643516182 Question Type : MCQ Option Shuffling : Yes Is Question Mandatory : No**

**Correct Marks : 4 Wrong Marks : 1**

जर P आणि Q ही दोन विधाने आहेत, तर खालीलपैकी कोणते मिश्र विधान (compound statement) अनुलाप (tautology) आहे ?

**Options :**

86435118545.  $((P \Rightarrow Q) \wedge \sim Q) \Rightarrow P$ 86435118546.  $((P \Rightarrow Q) \wedge \sim Q) \Rightarrow Q$ 86435118547.  $((P \Rightarrow Q) \wedge \sim Q) \Rightarrow \sim P$ 86435118548.  $((P \Rightarrow Q) \wedge \sim Q) \Rightarrow (P \wedge Q)$ 

**Question Number : 63 Question Id : 8643516183 Question Type : MCQ Option Shuffling : Yes Is Question Mandatory : No**

**Correct Marks : 4 Wrong Marks : 1**

A pole stands vertically inside a triangular park ABC. Let the angle of elevation of the top of the pole from each corner of the park be  $\frac{\pi}{3}$ . If the radius of the circumcircle of  $\Delta ABC$  is 2,

then the height of the pole is equal to :

Options :

86435118549.  $\frac{2\sqrt{3}}{3}$

86435118550.  $2\sqrt{3}$

86435118551.  $\frac{1}{\sqrt{3}}$

86435118552.  $\sqrt{3}$

Question Number : 63 Question Id : 8643516183 Question Type : MCQ Option Shuffling : Yes Is

Question Mandatory : No

Correct Marks : 4 Wrong Marks : 1

एका त्रिकोणी पार्क ABC मध्ये एक खांब (pole) उभा उभारला आहे. पार्कच्या प्रत्येक कोपऱ्यापासून खांबाच्या टोकाशी उन्नत कोन (angle of elevation)  $\frac{\pi}{3}$  आहे. जर  $\Delta ABC$  च्या परिवर्तुळाची त्रिज्या 2 आहे, तर त्या खांबाची उंची (height) बरोबर \_\_\_\_\_ आहे.

Options :

86435118549.  $\frac{2\sqrt{3}}{3}$

86435118550.  $2\sqrt{3}$

86435118551.  $\frac{1}{\sqrt{3}}$

86435118552.  $\sqrt{3}$

Question Number : 64 Question Id : 8643516184 Question Type : MCQ Option Shuffling : Yes Is

Question Mandatory : No

**Correct Marks : 4 Wrong Marks : 1**

Let in a series of  $2n$  observations, half of them are equal to  $a$  and remaining half are equal to  $-a$ . Also by adding a constant  $b$  in each of these observations, the mean and standard deviation of new set become 5 and 20, respectively. Then the value of  $a^2 + b^2$  is equal to :

**Options :**

86435118553. 925

86435118554. 425

86435118555. 650

86435118556. 250

**Question Number : 64 Question Id : 8643516184 Question Type : MCQ Option Shuffling : Yes Is**

**Question Mandatory : No**

**Correct Marks : 4 Wrong Marks : 1**

समजा  $2n$  निरीक्षणांच्या श्रेणी (series) मध्ये, निम्मे  $a$  च्या बरोबर आहेत आणि राहिलेले निम्मे  $-a$  च्या बरोबर आहेत. प्रत्येक निरीक्षणांमध्ये  $b$  हा अचल मिळविल्यावर येणाऱ्या नवीन संचाचा मध्य आणि प्रमाण विचलन (standard deviation) अनुक्रमे 5 आणि 20 आहेत. तर  $a^2 + b^2$  चे मूल्य बरोबर \_\_\_\_\_ आहे.

**Options :**

86435118553. 925

86435118554. 425

86435118555. 650

86435118556. 250

**Question Number : 65 Question Id : 8643516185 Question Type : MCQ Option Shuffling : Yes Is**

**Question Mandatory : No**

**Correct Marks : 4 Wrong Marks : 1**

Let in a Binomial distribution, consisting of 5 independent trials, probabilities of exactly 1 and 2 successes be 0.4096 and 0.2048 respectively. Then the probability of getting exactly 3 successes is equal to :

**Options :**

$$86435118557. \frac{40}{243}$$

$$86435118558. \frac{80}{243}$$

$$86435118559. \frac{128}{625}$$

$$86435118560. \frac{32}{625}$$

**Question Number : 65 Question Id : 8643516185 Question Type : MCQ Option Shuffling : Yes Is Question Mandatory : No**

**Correct Marks : 4 Wrong Marks : 1**

समजा 5 स्वतंत्र कसोटी (independent trials) चे एका द्विपद वितरण (Binomial distribution) मध्ये तंतोतंत 1 आणि 2 सफलतेची (successes) संभाव्यता अनुक्रमे 0.4096 आणि 0.2048 आहे. तर तंतोतंत 3 सफलतेची संभाव्यता बरोबर \_\_\_\_\_ आहे.

**Options :**

$$86435118557. \frac{40}{243}$$

$$86435118558. \frac{80}{243}$$

$$86435118559. \frac{128}{625}$$

$$86435118560. \frac{32}{625}$$

**Question Number : 66 Question Id : 8643516186 Question Type : MCQ Option Shuffling : Yes Is Question Mandatory : No**

**Correct Marks : 4 Wrong Marks : 1**

In a triangle ABC, if  $|\vec{BC}| = 8$ ,  $|\vec{CA}| = 7$ ,  $|\vec{AB}| = 10$ , then the projection of the vector  $\vec{AB}$  on  $\vec{AC}$  is equal to :

Options :

$$86435118561. \frac{115}{16}$$

$$86435118562. \frac{85}{14}$$

$$86435118563. \frac{127}{20}$$

$$86435118564. \frac{25}{4}$$

Question Number : 66 Question Id : 8643516186 Question Type : MCQ Option Shuffling : Yes Is Question Mandatory : No

Correct Marks : 4 Wrong Marks : 1

एका  $\Delta ABC$  मध्ये, जर  $|\vec{BC}| = 8$ ,  $|\vec{CA}| = 7$ ,  $|\vec{AB}| = 10$ , तर सदिश  $\vec{AB}$  चा सदिश  $\vec{AC}$  वरील प्रक्षेप (projection) बरोबर \_\_\_\_\_ आहे.

Options :

$$86435118561. \frac{115}{16}$$

$$86435118562. \frac{85}{14}$$

$$86435118563. \frac{127}{20}$$

$$86435118564. \frac{25}{4}$$

Question Number : 67 Question Id : 8643516187 Question Type : MCQ Option Shuffling : Yes Is Question Mandatory : No

Correct Marks : 4 Wrong Marks : 1

Let the centroid of an equilateral triangle ABC be at the origin. Let one of the sides of the equilateral triangle be along the straight line  $x + y = 3$ . If R and r be the radius of circumcircle and incircle respectively of  $\Delta ABC$ , then  $(R + r)$  is equal to :

**Options :**

86435118565.  $2\sqrt{2}$

86435118566.  $\frac{9}{\sqrt{2}}$

86435118567.  $7\sqrt{2}$

86435118568.  $3\sqrt{2}$

**Question Number : 67 Question Id : 8643516187 Question Type : MCQ Option Shuffling : Yes Is Question Mandatory : No**

**Correct Marks : 4 Wrong Marks : 1**

समजा समभुज त्रिकोण ABC चा मध्यगासंपात (centroid) आरंभ बिंदूवर आहे. समजा या समभुज त्रिकोणाची एक बाजू  $x+y=3$  या सरळ रेषेवर आहे. जर  $\Delta ABC$  च्या परिवर्तुळ आणि आंतरवर्तुळ यांची त्रिज्या अनुक्रमे  $R$  आणि  $r$  आहेत, तर  $(R+r)$  बरोबर \_\_\_\_\_ आहे.

**Options :**

86435118565.  $2\sqrt{2}$

86435118566.  $\frac{9}{\sqrt{2}}$

86435118567.  $7\sqrt{2}$

86435118568.  $3\sqrt{2}$

**Question Number : 68 Question Id : 8643516188 Question Type : MCQ Option Shuffling : Yes Is Question Mandatory : No**

**Correct Marks : 4 Wrong Marks : 1**

Let a tangent be drawn to the ellipse  $\frac{x^2}{27} + y^2 = 1$  at  $(3\sqrt{3}\cos\theta, \sin\theta)$  where  $\theta \in \left(0, \frac{\pi}{2}\right)$ .

Then the value of  $\theta$  such that the sum of intercepts on axes made by this tangent is minimum

is equal to :

**Options :**86435118569.  $\frac{\pi}{3}$ 86435118570.  $\frac{\pi}{6}$ 86435118571.  $\frac{\pi}{8}$ 86435118572.  $\frac{\pi}{4}$ 

**Question Number : 68 Question Id : 8643516188 Question Type : MCQ Option Shuffling : Yes Is Question Mandatory : No**

**Correct Marks : 4 Wrong Marks : 1**

समजा  $\frac{x^2}{27} + y^2 = 1$  या विवृत्तावर  $(3\sqrt{3}\cos\theta, \sin\theta)$  जेव्हा  $\theta \in \left(0, \frac{\pi}{2}\right)$  या बिंदूवर एक स्पर्शिका काढली आहे. तर  $\theta$  चे मूल्य, जसे की या स्पर्शिकेमुळे अक्षांवर तयार होणाऱ्या आंतरखंडांची (intercepts) बेरीज किमान (minimum) आहे, बरोबर \_\_\_\_\_ आहे.

**Options :**86435118569.  $\frac{\pi}{3}$ 86435118570.  $\frac{\pi}{6}$ 86435118571.  $\frac{\pi}{8}$ 86435118572.  $\frac{\pi}{4}$ 

**Question Number : 69 Question Id : 8643516189 Question Type : MCQ Option Shuffling : Yes Is Question Mandatory : No**

**Correct Marks : 4 Wrong Marks : 1**

Let  $y=y(x)$  be the solution of the differential equation  $\frac{dy}{dx} = (y + 1) \left( (y + 1)e^{x^{3/2}-x} \right)$ ,

$0 < x < 2.1$ , with  $y(2)=0$ . Then the value of  $\frac{dy}{dx}$  at  $x=1$  is equal to :

Options :

86435118573.  $\frac{e^{5/2}}{(1 + e^2)^2}$

86435118574.  $-\frac{2e^2}{(1 + e^2)^2}$

86435118575.  $\frac{5e^{1/2}}{(e^2 + 1)^2}$

86435118576.  $\frac{-e^{3/2}}{(e^2 + 1)^2}$

Question Number : 69 Question Id : 8643516189 Question Type : MCQ Option Shuffling : Yes Is Question Mandatory : No Correct Marks : 4 Wrong Marks : 1

समजा  $\frac{dy}{dx} = (y + 1) \left( (y + 1)e^{x^{3/2}-x} \right)$ ,  $0 < x < 2.1$ ,  $y(2)=0$  या विकलक समीकरणाची उकल  $y=y(x)$

आहे. तर  $x=1$  असताना  $\frac{dy}{dx}$  चे मूल्य बरोबर \_\_\_\_\_ आहे.

Options :

86435118573.  $\frac{e^{5/2}}{(1 + e^2)^2}$

86435118574.  $-\frac{2e^2}{(1 + e^2)^2}$

$$\frac{5e^{1/2}}{(e^2 + 1)^2}$$

86435118575.

$$\frac{-e^{3/2}}{(e^2 + 1)^2}$$

86435118576.

**Question Number : 70 Question Id : 8643516190 Question Type : MCQ Option Shuffling : Yes Is Question Mandatory : No**

**Correct Marks : 4 Wrong Marks : 1**

The area bounded by the curve  $4y^2 = x^2(4-x)(x-2)$  is equal to :

**Options :**

$$\frac{3\pi}{8}$$

86435118577.

$$\frac{\pi}{16}$$

86435118578.

$$\frac{\pi}{8}$$

86435118579.

$$\frac{3\pi}{2}$$

86435118580.

**Question Number : 70 Question Id : 8643516190 Question Type : MCQ Option Shuffling : Yes Is Question Mandatory : No**

**Correct Marks : 4 Wrong Marks : 1**

वक्र  $4y^2 = x^2(4-x)(x-2)$  द्वारे परिबद्ध (bounded) क्षेत्राचे क्षेत्रफळ बरोबर \_\_\_\_\_ आहे.

**Options :**

$$\frac{3\pi}{8}$$

86435118577.

$$\frac{\pi}{16}$$

86435118578.

$$\frac{\pi}{8}$$

86435118579.

86435118580.  $\frac{3\pi}{2}$

Question Number : 71 Question Id : 8643516191 Question Type : MCQ Option Shuffling : Yes Is

Question Mandatory : No

Correct Marks : 4 Wrong Marks : 1

Let  $g(x) = \int_0^x f(t)dt$ , where  $f$  is continuous function in  $[0, 3]$  such that  $\frac{1}{3} \leq f(t) \leq 1$  for all

$t \in [0, 1]$  and  $0 \leq f(t) \leq \frac{1}{2}$  for all  $t \in (1, 3]$ . The largest possible interval in which  $g(3)$  lies is :

Options :

86435118581.  $\left[\frac{1}{3}, 2\right]$

86435118582.  $\left[-1, -\frac{1}{2}\right]$

86435118583.  $[1, 3]$

86435118584.  $\left[-\frac{3}{2}, -1\right]$

Question Number : 71 Question Id : 8643516191 Question Type : MCQ Option Shuffling : Yes Is

Question Mandatory : No

Correct Marks : 4 Wrong Marks : 1

समजा  $g(x) = \int_0^x f(t)dt$ , जेव्हा  $[0, 3]$  मध्ये  $f$  हे संतत फल आहे. जसे की  $\frac{1}{3} \leq f(t) \leq 1$  सर्व

$t \in [0, 1]$  साठी आणि  $0 \leq f(t) \leq \frac{1}{2}$  सर्व  $t \in (1, 3]$  साठी.  $g(3)$  स्थित असणारे मोठे शक्य अंतराल (largest

possible interval) \_\_\_\_\_ आहे.

Options :

86435118581.  $\left[\frac{1}{3}, 2\right]$

86435118582.  $\left[-1, -\frac{1}{2}\right]$

86435118583.  $[1, 3]$

86435118584.  $\left[-\frac{3}{2}, -1\right]$

**Question Number : 72 Question Id : 8643516192 Question Type : MCQ Option Shuffling : Yes Is Question Mandatory : No Correct Marks : 4 Wrong Marks : 1**

Let  $f: \mathbb{R} \rightarrow \mathbb{R}$  be a function defined as

$$f(x) = \begin{cases} \frac{\sin(a+1)x + \sin 2x}{2x}, & \text{if } x < 0 \\ b, & \text{if } x = 0 \\ \frac{\sqrt{x + bx^3} - \sqrt{x}}{bx^{5/2}}, & \text{if } x > 0 \end{cases}$$

If  $f$  is continuous at  $x=0$ , then the value of  $a+b$  is equal to :

**Options :**

86435118585.  $-\frac{5}{2}$

86435118586.  $-3$

86435118587.  $-2$

86435118588.  $-\frac{3}{2}$

**Question Number : 72 Question Id : 8643516192 Question Type : MCQ Option Shuffling : Yes Is Question Mandatory : No Correct Marks : 4 Wrong Marks : 1**

समजा  $f: \mathbb{R} \rightarrow \mathbb{R}$  खालील द्वारे निश्चित आहे

$$f(x) = \begin{cases} \frac{\sin(a+1)x + \sin 2x}{2x}, & \text{जर } x < 0 \\ b, & \text{जर } x = 0 \\ \frac{\sqrt{x + bx^3} - \sqrt{x}}{bx^{5/2}}, & \text{जर } x > 0 \end{cases}$$

जर  $x=0$  वर  $f$  संतत आहे, तर  $a+b$  चे मूल्य बरोबर \_\_\_\_\_ आहे.

**Options :**

86435118585.  $-\frac{5}{2}$

86435118586.  $-3$

86435118587.  $-2$

86435118588.  $-\frac{3}{2}$

**Question Number : 73 Question Id : 8643516193 Question Type : MCQ Option Shuffling : Yes Is Question Mandatory : No**

**Correct Marks : 4 Wrong Marks : 1**

Let  $S_1$  be the sum of first  $2n$  terms of an arithmetic progression. Let  $S_2$  be the sum of first  $4n$  terms of the same arithmetic progression. If  $(S_2 - S_1)$  is 1000, then the sum of the first  $6n$  terms of the arithmetic progression is equal to :

**Options :**

86435118589. 7000

86435118590. 5000

86435118591. 3000

86435118592. 1000

Question Number : 73 Question Id : 8643516193 Question Type : MCQ Option Shuffling : Yes Is

Question Mandatory : No

Correct Marks : 4 Wrong Marks : 1

समजा एका गणित श्रेढी (A.P.) च्या पहिल्या  $2n$  पदांची बेरीज  $S_1$  आहे. समजा त्याच गणित श्रेढीच्या पहिल्या  $4n$  पदांची बेरीज  $S_2$  आहे. तर  $(S_2 - S_1) = 1000$ , तर या गणित श्रेढीच्या पहिल्या  $6n$  पदांची बेरीज बरोबर \_\_\_\_\_ आहे.

Options :

86435118589. 7000

86435118590. 5000

86435118591. 3000

86435118592. 1000

Question Number : 74 Question Id : 8643516194 Question Type : MCQ Option Shuffling : Yes Is

Question Mandatory : No

Correct Marks : 4 Wrong Marks : 1

Let  $S_1 : x^2 + y^2 = 9$  and  $S_2 : (x - 2)^2 + y^2 = 1$ . Then the locus of center of a variable circle  $S$  which touches  $S_1$  internally and  $S_2$  externally always passes through the points :

Options :

86435118593.  $\left(2, \pm \frac{3}{2}\right)$

86435118594.  $(0, \pm \sqrt{3})$

86435118595.  $(1, \pm 2)$

86435118596.  $\left(\frac{1}{2}, \pm \frac{\sqrt{5}}{2}\right)$

Question Number : 74 Question Id : 8643516194 Question Type : MCQ Option Shuffling : Yes Is

Question Mandatory : No

Correct Marks : 4 Wrong Marks : 1

समजा  $S_1 : x^2 + y^2 = 9$  आणि  $S_2 : (x-2)^2 + y^2 = 1$ . तर एका चल वर्तुळ  $S$  (a variable circle  $S$ ), जो  $S_1$  ला आतून स्पर्श करतो आणि  $S_2$  ला बाहेरून स्पर्श करत आहे, त्याच्या केंद्र बिंदूचे निधान नेहमी खालीलपैकी कोणत्या बिंदू मधून जाते.

**Options :**

86435118593.  $\left(2, \pm \frac{3}{2}\right)$

86435118594.  $(0, \pm \sqrt{3})$

86435118595.  $(1, \pm 2)$

86435118596.  $\left(\frac{1}{2}, \pm \frac{\sqrt{5}}{2}\right)$

**Question Number : 75 Question Id : 8643516195 Question Type : MCQ Option Shuffling : Yes Is**

**Question Mandatory : No**

**Correct Marks : 4 Wrong Marks : 1**

Let the system of linear equations

$$4x + \lambda y + 2z = 0$$

$$2x - y + z = 0$$

$$\mu x + 2y + 3z = 0, \lambda, \mu \in \mathbb{R}.$$

has a non-trivial solution. Then which of the following is true ?

**Options :**

86435118597.  $\lambda = 3, \mu \in \mathbb{R}$

86435118598.  $\mu = -6, \lambda \in \mathbb{R}$

86435118599.  $\lambda = 2, \mu \in \mathbb{R}$

86435118600.  $\mu = 6, \lambda \in \mathbb{R}$

**Question Number : 75 Question Id : 8643516195 Question Type : MCQ Option Shuffling : Yes Is**

**Question Mandatory : No**

**Correct Marks : 4 Wrong Marks : 1**

$$\text{समजा } 4x + \lambda y + 2z = 0$$

$$2x - y + z = 0$$

$$\mu x + 2y + 3z = 0, \lambda, \mu \in \mathbb{R}.$$

या रेखीय समीकरणाची प्रणाली क्षुल्लक उकल नसलेली (non-trivial solution) आहे. तर खालीलपैकी कोणते सत्य आहे ?

**Options :**

86435118597.  $\lambda = 3, \mu \in \mathbb{R}$

86435118598.  $\mu = -6, \lambda \in \mathbb{R}$

86435118599.  $\lambda = 2, \mu \in \mathbb{R}$

86435118600.  $\mu = 6, \lambda \in \mathbb{R}$

**Question Number : 76 Question Id : 8643516196 Question Type : MCQ Option Shuffling : Yes Is**

**Question Mandatory : No**

**Correct Marks : 4 Wrong Marks : 1**

Let  $f: \mathbb{R} - \{3\} \rightarrow \mathbb{R} - \{1\}$  be defined by  $f(x) = \frac{x-2}{x-3}$ .

Let  $g: \mathbb{R} \rightarrow \mathbb{R}$  be given as  $g(x) = 2x - 3$ . Then, the sum of all the values of  $x$  for which

$f^{-1}(x) + g^{-1}(x) = \frac{13}{2}$  is equal to.

**Options :**

86435118601. 2

86435118602. 5

86435118603. 3

86435118604. 7

**Question Number : 76 Question Id : 8643516196 Question Type : MCQ Option Shuffling : Yes Is**

**Question Mandatory : No**

**Correct Marks : 4 Wrong Marks : 1**

समजा  $f: \mathbb{R} - \{3\} \rightarrow \mathbb{R} - \{1\}$ ,  $f(x) = \frac{x-2}{x-3}$  द्वारे निश्चित आहे. समजा  $g: \mathbb{R} \rightarrow \mathbb{R}$ ,  $g(x) = 2x - 3$  द्वारे

निश्चित आहे. तर  $x$  च्या सर्व मूल्यांची बेरीज, ज्या साठी  $f^{-1}(x) + g^{-1}(x) = \frac{13}{2}$  आहे, बरोबर \_\_\_\_\_

आहे.

**Options :**

86435118601. 2

86435118602. 5

86435118603. 3

86435118604. 7

**Question Number : 77 Question Id : 8643516197 Question Type : MCQ Option Shuffling : Yes Is Question Mandatory : No**

**Correct Marks : 4 Wrong Marks : 1**

Let a complex number be  $w = 1 - \sqrt{3}i$ . Let another complex number  $z$  be such that  $|zw| = 1$  and  $\arg(z) - \arg(w) = \frac{\pi}{2}$ . Then the area of the triangle with vertices origin,  $z$  and  $w$  is equal

to :

**Options :**

86435118605.  $\frac{1}{2}$

86435118606. 2

86435118607.  $\frac{1}{4}$

86435118608. 4

**Question Number : 77 Question Id : 8643516197 Question Type : MCQ Option Shuffling : Yes Is Question Mandatory : No**

**Correct Marks : 4 Wrong Marks : 1**

समजा  $w = 1 - \sqrt{3}i$  हे एक संमिश्र संख्या (complex number) आहे. समजा दुसरी संमिश्र संख्या  $z$  अशा प्रकारे आहे की  $|zw| = 1$  आणि  $\arg(z) - \arg(w) = \frac{\pi}{2}$  आहे. तर आरंभ बिंदू  $z$  आणि  $w$  हे शिरोबिंदू असणाऱ्या त्रिकोणाचे क्षेत्रफळ बरोबर \_\_\_\_\_ आहे.

**Options :**

86435118605.  $\frac{1}{2}$

86435118606. 2

86435118607.  $\frac{1}{4}$

86435118608. 4

**Question Number : 78 Question Id : 8643516198 Question Type : MCQ Option Shuffling : Yes Is Question Mandatory : No**

**Correct Marks : 4 Wrong Marks : 1**

Define a relation  $R$  over a class of  $n \times n$  real matrices  $A$  and  $B$  as

“ $ARB$  iff there exists a non-singular matrix  $P$  such that  $PAP^{-1} = B$ ”.

Then which of the following is true ?

**Options :**

86435118609.  $R$  is reflexive, symmetric but not transitive

86435118610.  $R$  is reflexive, transitive but not symmetric

86435118611.  $R$  is symmetric, transitive but not reflexive,

86435118612.  $R$  is an equivalence relation

**Question Number : 78 Question Id : 8643516198 Question Type : MCQ Option Shuffling : Yes Is Question Mandatory : No**

**Correct Marks : 4 Wrong Marks : 1**

$n \times n$  च्या वास्तव सारणी A आणि B वर एक संबंध R खालील प्रकारे निश्चित आहे.

“ARB जर आणि केवळ जर एक संविशेष नसलेली सारणी (non-singular matrix) P चे अस्तित्व आहे ज्या साठी  $PAP^{-1} = B$ ” आहे.

तर खालीलपैकी कोणते सत्य आहे ?

**Options :**

86435118609. R हे स्वलक्षी, सममित परंतु संक्रामक नाही आहे.

86435118610. R हे स्वलक्षी, संक्रामक परंतु सममित नाही आहे.

86435118611. R हे सममित, संक्रामक परंतु स्वलक्षी नाही आहे.

86435118612. R हे सममूल्यता संबंध आहे.

**Question Number : 79 Question Id : 8643516199 Question Type : MCQ Option Shuffling : Yes Is Question Mandatory : No**

**Correct Marks : 4 Wrong Marks : 1**

Consider a hyperbola  $H : x^2 - 2y^2 = 4$ . Let the tangent at a point  $P (4, \sqrt{6})$  meet the  $x$ -axis at  $Q$  and latus rectum at  $R (x_1, y_1)$ ,  $x_1 > 0$ . If  $F$  is a focus of  $H$  which is nearer to the point  $P$ , then the area of  $\Delta QFR$  is equal to .

**Options :**

86435118613.  $\sqrt{6} - 1$

86435118614.  $\frac{7}{\sqrt{6}} - 2$

86435118615.  $4\sqrt{6} - 1$

86435118616.  $4\sqrt{6}$

**Question Number : 79 Question Id : 8643516199 Question Type : MCQ Option Shuffling : Yes Is Question Mandatory : No**

**Correct Marks : 4 Wrong Marks : 1**

H :  $x^2 - 2y^2 = 4$  या अपास्त (hyperbola) चा विचार करा. समजा P  $(4, \sqrt{6})$  या बिंदू वरील स्पर्शिका x-अक्षाला Q मध्ये मिळते आणि नाभिलंब (Latus rectum) ला R  $(x_1, y_1)$ ,  $x_1 > 0$  वर मिळते. जर H ची नाभि (focus) F, बिंदू P च्या जवळ आहे, तर  $\Delta QFR$  चे क्षेत्रफळ बरोबर \_\_\_\_\_ आहे.

**Options :**

86435118613.  $\sqrt{6} - 1$

86435118614.  $\frac{7}{\sqrt{6}} - 2$

86435118615.  $4\sqrt{6} - 1$

86435118616.  $4\sqrt{6}$

**Question Number : 80 Question Id : 8643516200 Question Type : MCQ Option Shuffling : Yes Is**

**Question Mandatory : No**

**Correct Marks : 4 Wrong Marks : 1**

Let  $\vec{a}$  and  $\vec{b}$  be two non-zero vectors perpendicular to each other and  $|\vec{a}| = |\vec{b}|$ . If

$|\vec{a} \times \vec{b}| = |\vec{a}|$ , then the angle between the vectors  $(\vec{a} + \vec{b} + (\vec{a} \times \vec{b}))$  and  $\vec{a}$  is equal to :

**Options :**

86435118617.  $\cos^{-1}\left(\frac{1}{\sqrt{3}}\right)$

86435118618.  $\cos^{-1}\left(\frac{1}{\sqrt{2}}\right)$

86435118619.  $\sin^{-1}\left(\frac{1}{\sqrt{3}}\right)$

86435118620.  $\sin^{-1}\left(\frac{1}{\sqrt{6}}\right)$

Question Number : 80 Question Id : 8643516200 Question Type : MCQ Option Shuffling : Yes Is

Question Mandatory : No

Correct Marks : 4 Wrong Marks : 1

समजा  $\vec{a}$  आणि  $\vec{b}$  हे दोन शून्येतर सदिश आहेत ते एकमेकांना लंब आहेत आणि  $|\vec{a}| = |\vec{b}|$ . जर

$|\vec{a} \times \vec{b}| = |\vec{a}|$ , तर  $(\vec{a} + \vec{b} + (\vec{a} \times \vec{b}))$  आणि  $\vec{a}$  या सदिशांमधील कोन बरोबर \_\_\_\_\_ आहे.

Options :

86435118617.  $\cos^{-1}\left(\frac{1}{\sqrt{3}}\right)$

86435118618.  $\cos^{-1}\left(\frac{1}{\sqrt{2}}\right)$

86435118619.  $\sin^{-1}\left(\frac{1}{\sqrt{3}}\right)$

86435118620.  $\sin^{-1}\left(\frac{1}{\sqrt{6}}\right)$

## Mathematics Section B

Section Id :	864351414
Section Number :	6
Section type :	Online
Mandatory or Optional :	Mandatory
Number of Questions :	10
Number of Questions to be attempted :	5
Section Marks :	20
Mark As Answered Required? :	Yes
Sub-Section Number :	1
Sub-Section Id :	864351414
Question Shuffling Allowed :	Yes

Question Number : 81 Question Id : 8643516201 Question Type : SA

Correct Marks : 4 Wrong Marks : 0

If  $f(x)$  and  $g(x)$  are two polynomials such that the polynomial  $P(x) = f(x^3) + x g(x^3)$  is divisible by  $x^2 + x + 1$ , then  $P(1)$  is equal to \_\_\_\_\_.

**Response Type :** Numeric

**Evaluation Required For SA :** Yes

**Show Word Count :** Yes

**Answers Type :** Equal

**Text Areas :** PlainText

**Possible Answers :**

100

**Question Number :** 81 **Question Id :** 8643516201 **Question Type :** SA

**Correct Marks :** 4 **Wrong Marks :** 0

जर  $f(x)$  आणि  $g(x)$  या दोन बहुपदी (polynomials) आहेत जसे की  $P(x) = f(x^3) + x g(x^3)$  ही बहुपदी  $x^2 + x + 1$  ने विभाजीत आहे, तर  $P(1)$  बरोबर \_\_\_\_\_ आहे.

**Response Type :** Numeric

**Evaluation Required For SA :** Yes

**Show Word Count :** Yes

**Answers Type :** Equal

**Text Areas :** PlainText

**Possible Answers :**

100

**Question Number :** 82 **Question Id :** 8643516202 **Question Type :** SA

**Correct Marks :** 4 **Wrong Marks :** 0

Let  $I$  be an identity matrix of order  $2 \times 2$  and  $P = \begin{bmatrix} 2 & -1 \\ 5 & -3 \end{bmatrix}$ . Then the value of  $n \in \mathbb{N}$  for which

$P^n = 5I - 8P$  is equal to \_\_\_\_\_.

**Response Type :** Numeric

**Evaluation Required For SA :** Yes

**Show Word Count :** Yes

**Answers Type :** Equal

**Text Areas :** PlainText

**Possible Answers :**

100

**Question Number :** 82 **Question Id :** 8643516202 **Question Type :** SA

**Correct Marks :** 4 **Wrong Marks :** 0

समजा  $I$ , कोटिका  $2 \times 2$  ची अविकारक सारणी (identity matrix) आहे आणि  $P = \begin{bmatrix} 2 & -1 \\ 5 & -3 \end{bmatrix}$ . तर  $n \in \mathbb{N}$

चे मूल्य, ज्या साठी  $P^n = 5I - 8P$  आहे, बरोबर \_\_\_\_\_ आहे.

**Response Type :** Numeric

**Evaluation Required For SA :** Yes

**Show Word Count :** Yes

**Answers Type :** Equal

**Text Areas :** PlainText

**Possible Answers :**

100

**Question Number :** 83 **Question Id :** 8643516203 **Question Type :** SA

**Correct Marks :** 4 **Wrong Marks :** 0

The term independent of  $x$  in the expansion of  $\left[ \frac{x+1}{x^{2/3} - x^{1/3} + 1} - \frac{x-1}{x - x^{1/2}} \right]^{10}$ ,  $x \neq 1$ , is equal to \_\_\_\_\_.

**Response Type :** Numeric

**Evaluation Required For SA :** Yes

**Show Word Count :** Yes

**Answers Type :** Equal

**Text Areas :** PlainText

**Possible Answers :**

100

**Question Number :** 83 **Question Id :** 8643516203 **Question Type :** SA

**Correct Marks :** 4 **Wrong Marks :** 0

$\left[ \frac{x+1}{x^{2/3} - x^{1/3} + 1} - \frac{x-1}{x - x^{1/2}} \right]^{10}$ ,  $x \neq 1$ , या विस्तारामधील  $x$  चे अनधीन (independent) पद बरोबर \_\_\_\_\_ आहे.

**Response Type :** Numeric

**Evaluation Required For SA :** Yes

**Show Word Count :** Yes

**Answers Type :** Equal

**Text Areas :** PlainText

**Possible Answers :**

100

Question Number : 84 Question Id : 8643516204 Question Type : SA

Correct Marks : 4 Wrong Marks : 0

If  $\sum_{r=1}^{10} r! (r^3 + 6r^2 + 2r + 5) = \alpha (11!),$

then the value of  $\alpha$  is equal to \_\_\_\_\_.

Response Type : Numeric

Evaluation Required For SA : Yes

Show Word Count : Yes

Answers Type : Equal

Text Areas : PlainText

Possible Answers :

100

Question Number : 84 Question Id : 8643516204 Question Type : SA

Correct Marks : 4 Wrong Marks : 0

जर  $\sum_{r=1}^{10} r! (r^3 + 6r^2 + 2r + 5) = \alpha (11!),$  तर  $\alpha$  चे मूल्य बरोबर \_\_\_\_\_ आहे.

Response Type : Numeric

Evaluation Required For SA : Yes

Show Word Count : Yes

Answers Type : Equal

Text Areas : PlainText

Possible Answers :

100

Question Number : 85 Question Id : 8643516205 Question Type : SA

Correct Marks : 4 Wrong Marks : 0

Let  $P(x)$  be a real polynomial of degree 3 which vanishes at  $x = -3$ . Let  $P(x)$  have local

minima at  $x = 1$ , local maxima at  $x = -1$  and  $\int_{-1}^1 P(x) dx = 18$ , then the sum of all the coefficients

of the polynomial  $P(x)$  is equal to \_\_\_\_\_.

Response Type : Numeric

Evaluation Required For SA : Yes

Show Word Count : Yes

Answers Type : Equal

Text Areas : PlainText

Possible Answers :

100

Question Number : 85 Question Id : 8643516205 Question Type : SA

Correct Marks : 4 Wrong Marks : 0

समजा  $P(x)$  ही कोटी 3 ची वास्तव बहुपदी आहे, जी  $x = -3$  वर शून्य होते. समजा  $P(x)$  चे स्थानिक लघुत्तमे

$x = 1$  वर, स्थानिक महत्तमे  $x = -1$  वर आणि  $\int_{-1}^1 P(x) dx = 18$  आहे, तर  $P(x)$  या बहुपदीच्या सर्व सहगुणकांची

बेरीज बरोबर \_\_\_\_\_ आहे.

Response Type : Numeric

Evaluation Required For SA : Yes

Show Word Count : Yes

Answers Type : Equal

Text Areas : PlainText

Possible Answers :

100

Question Number : 86 Question Id : 8643516206 Question Type : SA

Correct Marks : 4 Wrong Marks : 0

Let  $y = y(x)$  be the solution of the differential equation  $xdy - ydx = \sqrt{(x^2 - y^2)} dx$ ,  $x \geq 1$ , with  $y(1) = 0$ . If the area bounded by the line  $x = 1$ ,  $x = e^\pi$ ,  $y = 0$  and  $y = y(x)$  is  $\alpha e^{2\pi} + \beta$ , then the value of  $10(\alpha + \beta)$  is equal to \_\_\_\_\_.

Response Type : Numeric

Evaluation Required For SA : Yes

Show Word Count : Yes

Answers Type : Equal

Text Areas : PlainText

Possible Answers :

100

Question Number : 86 Question Id : 8643516206 Question Type : SA

Correct Marks : 4 Wrong Marks : 0

समजा  $xdy - ydx = \sqrt{(x^2 - y^2)} dx$ ,  $x \geq 1$ , या विकलक समीकरणाची उकल  $y = y(x)$  आहे. जसे  $y(1) = 0$ .

जर रेषा  $x = 1$ ,  $x = e^\pi$ ,  $y = 0$  आणि  $y = y(x)$  यांच्या द्वारे तयार होणाऱ्या क्षेत्राचे क्षेत्रफळ  $\alpha e^{2\pi} + \beta$  आहे, तर  $10(\alpha + \beta)$  चे मूल्य बरोबर \_\_\_\_\_ आहे.

Response Type : Numeric

Evaluation Required For SA : Yes

Show Word Count : Yes

Answers Type : Equal

Text Areas : PlainText

Possible Answers :

100

Question Number : 87 Question Id : 8643516207 Question Type : SA

Correct Marks : 4 Wrong Marks : 0

Let P be a plane containing the line  $\frac{x-1}{3} = \frac{y+6}{4} = \frac{z+5}{2}$  and parallel to the line

$\frac{x-3}{4} = \frac{y-2}{-3} = \frac{z+5}{7}$ . If the point  $(1, -1, \alpha)$  lies on the plane P, then the value of  $|5\alpha|$  is equal to \_\_\_\_\_.

Response Type : Numeric

Evaluation Required For SA : Yes

Show Word Count : Yes

Answers Type : Equal

Text Areas : PlainText

Possible Answers :

100

Question Number : 87 Question Id : 8643516207 Question Type : SA

Correct Marks : 4 Wrong Marks : 0

समजा P हे एक प्रतल आहे ज्या मध्ये रेषा  $\frac{x-1}{3} = \frac{y+6}{4} = \frac{z+5}{2}$  स्थित आहे आणि  $\frac{x-3}{4} = \frac{y-2}{-3} = \frac{z+5}{7}$

या रेषेला समांतर आहे. जर  $(1, -1, \alpha)$  हा बिंदू P प्रतलावर आहे, तर  $|5\alpha|$  चे मूल्य बरोबर \_\_\_\_\_ आहे.

Response Type : Numeric

Evaluation Required For SA : Yes

Show Word Count : Yes

Answers Type : Equal

Text Areas : PlainText

Possible Answers :

100

Question Number : 88 Question Id : 8643516208 Question Type : SA

Correct Marks : 4 Wrong Marks : 0

Let the mirror image of the point  $(1, 3, a)$  with respect to the plane  $\vec{r} \cdot (2\hat{i} - \hat{j} + \hat{k}) - b = 0$

be  $(-3, 5, 2)$ . Then, the value of  $|a + b|$  is equal to \_\_\_\_\_.

**Response Type :** Numeric

**Evaluation Required For SA :** Yes

**Show Word Count :** Yes

**Answers Type :** Equal

**Text Areas :** PlainText

**Possible Answers :**

100

**Question Number :** 88 **Question Id :** 8643516208 **Question Type :** SA

**Correct Marks :** 4 **Wrong Marks :** 0

समजा  $\vec{r} \cdot (2\hat{i} - \hat{j} + \hat{k}) - b = 0$  या प्रतलाच्या संदर्भात  $(1, 3, a)$  या बिंदूचे आरशातील प्रतिबिंब

$(-3, 5, 2)$  आहे. तर  $|a + b|$  चे मूल्य बरोबर \_\_\_\_\_ आहे.

**Response Type :** Numeric

**Evaluation Required For SA :** Yes

**Show Word Count :** Yes

**Answers Type :** Equal

**Text Areas :** PlainText

**Possible Answers :**

100

**Question Number :** 89 **Question Id :** 8643516209 **Question Type :** SA

**Correct Marks :** 4 **Wrong Marks :** 0

Let  ${}^nC_r$  denote the binomial coefficient of  $x^r$  in the expansion of  $(1+x)^n$ .

If  $\sum_{k=0}^{10} (2^2 + 3k) {}^nC_k = \alpha \cdot 3^{10} + \beta \cdot 2^{10}$ ,  $\alpha, \beta \in \mathbb{R}$ , then  $\alpha + \beta$  is equal to \_\_\_\_\_.

**Response Type :** Numeric

**Evaluation Required For SA :** Yes

**Show Word Count :** Yes

**Answers Type :** Equal

**Text Areas :** PlainText

**Possible Answers :**

100

**Question Number :** 89 **Question Id :** 8643516209 **Question Type :** SA

**Correct Marks :** 4 **Wrong Marks :** 0

समजा  $(1+x)^n$  या विस्तारामध्ये  $x^r$  चे द्विपद सहगुणक (binomial coefficient)  ${}^nC_r$  ने दर्शविते.

जर  $\sum_{k=0}^{10} (2^2 + 3k) {}^nC_k = \alpha \cdot 3^{10} + \beta \cdot 2^{10}$ ,  $\alpha, \beta \in \mathbb{R}$ , तर  $\alpha + \beta$  बरोबर \_\_\_\_\_ आहे.

**Response Type :** Numeric

**Evaluation Required For SA :** Yes

**Show Word Count :** Yes

**Answers Type :** Equal

**Text Areas :** PlainText

**Possible Answers :**

100

**Question Number :** 90 **Question Id :** 8643516210 **Question Type :** SA

**Correct Marks :** 4 **Wrong Marks :** 0

Let  $f: \mathbb{R} \rightarrow \mathbb{R}$  satisfy the equation  $f(x+y) = f(x) \cdot f(y)$  for all  $x, y \in \mathbb{R}$  and  $f(x) \neq 0$  for any  $x \in \mathbb{R}$ .

If the function  $f$  is differentiable at  $x=0$  and  $f'(0)=3$ , then  $\lim_{h \rightarrow 0} \frac{1}{h} (f(h) - 1)$  is equal to

\_\_\_\_\_.

**Response Type :** Numeric

**Evaluation Required For SA :** Yes

**Show Word Count :** Yes

**Answers Type :** Equal

**Text Areas :** PlainText

**Possible Answers :**

100

**Question Number :** 90 **Question Id :** 8643516210 **Question Type :** SA

**Correct Marks :** 4 **Wrong Marks :** 0

समजा  $f: \mathbb{R} \rightarrow \mathbb{R}$ ,  $f(x+y) = f(x) \cdot f(y)$  सर्व  $x, y \in \mathbb{R}$  साठी, या समीकरणाचे समाधान करते आणि  $f(x) \neq 0$  कोणत्याही  $x \in \mathbb{R}$  साठी.

जर फल  $f$  बिंदू  $x=0$  वर विकलनीय आहे आणि  $f'(0)=3$ , तर  $\lim_{h \rightarrow 0} \frac{1}{h} (f(h) - 1)$  बरोबर \_\_\_\_\_

आहे.

**Response Type :** Numeric

**Evaluation Required For SA :** Yes

**Show Word Count :** Yes

**Answers Type :** Equal

**Text Areas :** PlainText

**Possible Answers :**

100

