

**Question Paper Name :** B TECH 25th Feb 2021 Shift 2  
**Subject Name :** B TECH  
**Creation Date :** 2021-02-24 19:00:27  
**Duration :** 180  
**Number of Questions :** 90  
**Total Marks :** 300  
**Display Marks:** Yes

## B TECH

**Group Number :** 1  
**Group Id :** 708191202  
**Group Maximum Duration :** 0  
**Group Minimum Duration :** 180  
**Show Attended Group? :** No  
**Edit Attended Group? :** No  
**Break time :** 0  
**Group Marks :** 300  
**Is this Group for Examiner? :** No

## Physics Section A

**Section Id :** 708191790  
**Section Number :** 1  
**Section type :** Online

<b>Mandatory or Optional :</b>	Mandatory
<b>Number of Questions :</b>	20
<b>Number of Questions to be attempted :</b>	20
<b>Section Marks :</b>	80
<b>Mark As Answered Required? :</b>	Yes
<b>Sub-Section Number :</b>	1
<b>Sub-Section Id :</b>	7081911070
<b>Question Shuffling Allowed :</b>	Yes

**Question Number : 1 Question Id : 70819118754 Question Type : MCQ Option Shuffling : Yes Is**

**Question Mandatory : No**

**Correct Marks : 4 Wrong Marks : 1**

If  $e$  is the electronic charge,  $c$  is the speed of light in free space and  $h$  is Planck's constant, the

quantity  $\frac{1}{4\pi\epsilon_0} \frac{|e|^2}{\hbar c}$  has dimensions of :

**Options :**

70819161411.  $[M L T^0]$

70819161412.  $[M L T^{-1}]$

70819161413.  $[M^0 L^0 T^0]$

70819161414.  $[L C^{-1}]$

**Question Number : 2 Question Id : 70819118755 Question Type : MCQ Option Shuffling : Yes Is**

**Question Mandatory : No**

**Correct Marks : 4 Wrong Marks : 1**

A stone is dropped from the top of a building. When it crosses a point 5 m below the top, another stone starts to fall from a point 25 m below the top. Both stones reach the bottom of building simultaneously. The height of the building is :

**Options :**

70819161415. 45 m

70819161416. 25 m

70819161417. 35 m

70819161418. 50 m

**Question Number : 3 Question Id : 70819118756 Question Type : MCQ Option Shuffling : Yes Is**

**Question Mandatory : No**

**Correct Marks : 4 Wrong Marks : 1**

A sphere of radius 'a' and mass 'm' rolls along a horizontal plane with constant speed  $v_0$ . It encounters an inclined plane at angle  $\theta$  and climbs upward. Assuming that it rolls without slipping, how far up the sphere will travel ?

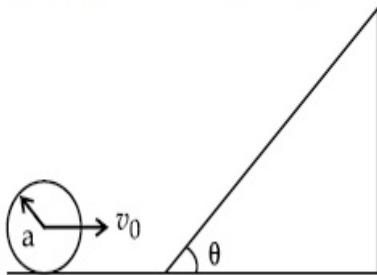

**Options :**

70819161419.  $\frac{v_0^2}{2g \sin\theta}$

70819161420.  $\frac{v_0^2}{5g \sin\theta}$

70819161421.  $\frac{10v_0^2}{7g \sin\theta}$

70819161422.  $\frac{2}{5} \frac{v_0^2}{g \sin\theta}$

Question Number : 4 Question Id : 70819118757 Question Type : MCQ Option Shuffling : Yes Is

Question Mandatory : No

Correct Marks : 4 Wrong Marks : 1

The point A moves with a uniform speed along the circumference of a circle of radius 0.36 m and covers  $30^\circ$  in 0.1 s. The perpendicular projection 'P' from 'A' on the diameter MN represents the simple harmonic motion of 'P'. The restoration force per unit mass when P touches M will be :

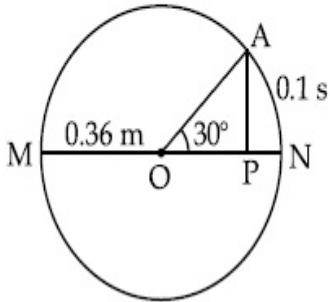

Options :

70819161423. 100 N

70819161424. 9.87 N

70819161425. 50 N

70819161426. 0.49 N

Question Number : 5 Question Id : 70819118758 Question Type : MCQ Option Shuffling : Yes Is

Question Mandatory : No

Correct Marks : 4 Wrong Marks : 1

Thermodynamic process is shown below on a P-V diagram for one mole of an ideal gas. If  $V_2 = 2V_1$  then the ratio of temperature  $T_2/T_1$  is :

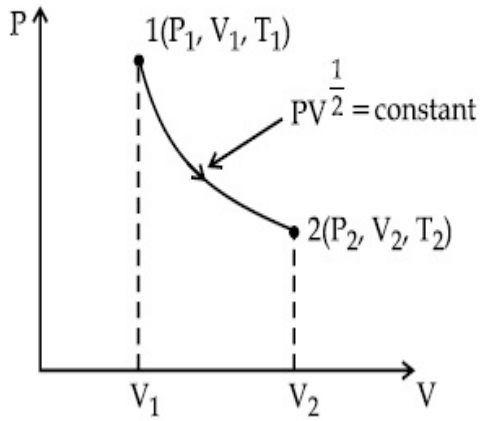

Options :

70819161427.  $\frac{1}{\sqrt{2}}$

70819161428.  $\sqrt{2}$

70819161429.  $\frac{1}{2}$

70819161430. 2

Question Number : 6 Question Id : 70819118759 Question Type : MCQ Option Shuffling : Yes Is

Question Mandatory : No

Correct Marks : 4 Wrong Marks : 1

Given below are two statements :

Statement I : In a diatomic molecule, the rotational energy at a given temperature obeys Maxwell's distribution.

Statement II : In a diatomic molecule, the rotational energy at a given temperature equals the translational kinetic energy for each molecule.

In the light of the above statements, choose the correct answer from the options given below :

Options :

70819161431. Both Statement I and Statement II are true.

70819161432. Both Statement I and Statement II are false.

70819161433. Statement I is true but Statement II is false.

70819161434. Statement I is false but Statement II is true.

Question Number : 7 Question Id : 70819118760 Question Type : MCQ Option Shuffling : Yes Is Question Mandatory : No

Correct Marks : 4 Wrong Marks : 1

Two identical springs of spring constant '2k' are attached to a block of mass m and to fixed support (see figure). When the mass is displaced from equilibrium position on either side, it executes simple harmonic motion. The time period of oscillations of this system is :

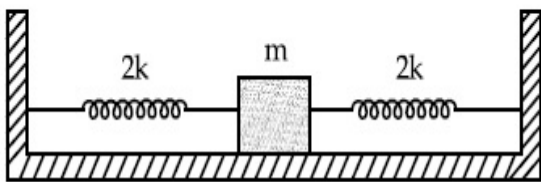

Options :

70819161435.  $2\pi \sqrt{\frac{m}{2k}}$

70819161436.  $2\pi \sqrt{\frac{m}{k}}$

70819161437.  $\pi \sqrt{\frac{m}{k}}$

70819161438.  $\pi \sqrt{\frac{m}{2k}}$

Question Number : 8 Question Id : 70819118761 Question Type : MCQ Option Shuffling : Yes Is Question Mandatory : No

Correct Marks : 4 Wrong Marks : 1

$Y = A \sin(\omega t + \phi_0)$  is the time-displacement equation of a SHM. At  $t=0$  the displacement of the particle is  $Y = \frac{A}{2}$  and it is moving along negative  $x$ -direction. Then the initial phase angle  $\phi_0$  will be :

Options :

70819161439.  $\frac{\pi}{3}$

70819161440.  $\frac{5\pi}{6}$

70819161441.  $\frac{\pi}{6}$

70819161442.  $\frac{2\pi}{3}$

Question Number : 9 Question Id : 70819118762 Question Type : MCQ Option Shuffling : Yes Is Question Mandatory : No

Correct Marks : 4 Wrong Marks : 1

A charge 'q' is placed at one corner of a cube as shown in figure. The flux of electrostatic field  $\vec{E}$  through the shaded area is :

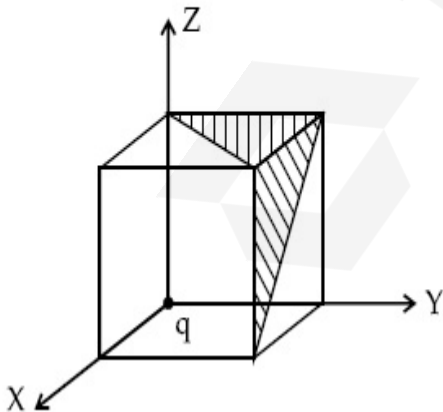

Options :

70819161443.  $\frac{q}{48\epsilon_0}$

70819161444.  $\frac{q}{4\epsilon_0}$

70819161445.  $\frac{q}{8\epsilon_0}$

70819161446.  $\frac{q}{24\epsilon_0}$

**Question Number : 10 Question Id : 70819118763 Question Type : MCQ Option Shuffling : Yes**

**Is Question Mandatory : No**

**Correct Marks : 4 Wrong Marks : 1**

An electron with kinetic energy  $K_1$  enters between parallel plates of a capacitor at an angle ' $\alpha$ ' with the plates. It leaves the plates at angle ' $\beta$ ' with kinetic energy  $K_2$ . Then the ratio of kinetic energies  $K_1 : K_2$  will be :

**Options :**

70819161447.  $\frac{\cos\beta}{\cos\alpha}$

70819161448.  $\frac{\cos\beta}{\sin\alpha}$

70819161449.  $\frac{\sin^2\beta}{\cos^2\alpha}$

70819161450.  $\frac{\cos^2\beta}{\cos^2\alpha}$

**Question Number : 11 Question Id : 70819118764 Question Type : MCQ Option Shuffling : Yes**

**Is Question Mandatory : No**

**Correct Marks : 4 Wrong Marks : 1**

In a ferromagnetic material, below the curie temperature, a domain is defined as :

**Options :**

70819161451. a macroscopic region with zero magnetization.
70819161452. a macroscopic region with saturation magnetization.
70819161453. a macroscopic region with randomly oriented magnetic dipoles.
70819161454. a macroscopic region with consecutive magnetic dipoles oriented in opposite direction.

**Question Number : 12 Question Id : 70819118765 Question Type : MCQ Option Shuffling : Yes**

**Is Question Mandatory : No**

**Correct Marks : 4 Wrong Marks : 1**

An LCR circuit contains resistance of  $110 \Omega$  and a supply of  $220 \text{ V}$  at  $300 \text{ rad/s}$  angular frequency. If only capacitance is removed from the circuit, current lags behind the voltage by  $45^\circ$ . If on the other hand, only inductor is removed the current leads by  $45^\circ$  with the applied voltage. The rms current flowing in the circuit will be :

**Options :**

70819161455. 1 A
70819161456. 1.5 A
70819161457. 2 A
70819161458. 2.5 A

**Question Number : 13 Question Id : 70819118766 Question Type : MCQ Option Shuffling : Yes**

**Is Question Mandatory : No**

**Correct Marks : 4 Wrong Marks : 1**

The stopping potential for electrons emitted from a photosensitive surface illuminated by light of wavelength 491 nm is 0.710 V. When the incident wavelength is changed to a new value, the stopping potential is 1.43 V. The new wavelength is :

**Options :**

70819161459. 309 nm

70819161460. 329 nm

70819161461. 382 nm

70819161462. 400 nm

**Question Number : 14 Question Id : 70819118767 Question Type : MCQ Option Shuffling : Yes**

**Is Question Mandatory : No**

**Correct Marks : 4 Wrong Marks : 1**

Consider the diffraction pattern obtained from the sunlight incident on a pinhole of diameter 0.1  $\mu\text{m}$ . If the diameter of the pinhole is slightly increased, it will affect the diffraction pattern such that :

**Options :**

70819161463. its size increases, and intensity increases

70819161464. its size increases, but intensity decreases

70819161465. its size decreases, but intensity increases

70819161466. its size decreases, and intensity decreases

**Question Number : 15 Question Id : 70819118768 Question Type : MCQ Option Shuffling : Yes**

**Is Question Mandatory : No**

**Correct Marks : 4 Wrong Marks : 1**

An electron of mass  $m_e$  and a proton of mass  $m_p = 1836 m_e$  are moving with the same speed.

The ratio of their de Broglie wavelength  $\frac{\lambda_{\text{electron}}}{\lambda_{\text{proton}}}$  will be :

**Options :**

70819161467. 1

70819161468. 1836

70819161469.  $\frac{1}{1836}$

70819161470. 918

**Question Number : 16 Question Id : 70819118769 Question Type : MCQ Option Shuffling : Yes**

**Is Question Mandatory : No**

**Correct Marks : 4 Wrong Marks : 1**

The wavelength of the photon emitted by a hydrogen atom when an electron makes a transition from  $n=2$  to  $n=1$  state is :

**Options :**

70819161471. 121.8 nm

70819161472. 194.8 nm

70819161473. 490.7 nm

70819161474. 913.3 nm

**Question Number : 17 Question Id : 70819118770 Question Type : MCQ Option Shuffling : Yes**

**Is Question Mandatory : No**

**Correct Marks : 4 Wrong Marks : 1**

If a message signal of frequency ' $f_m$ ' is amplitude modulated with a carrier signal of frequency ' $f_c$ ' and radiated through an antenna, the wavelength of the corresponding signal in air is :

**Options :**

70819161475.  $\frac{c}{f_c - f_m}$

70819161476.  $\frac{c}{f_c + f_m}$

70819161477.  $\frac{c}{f_c}$

70819161478.  $\frac{c}{f_m}$

**Question Number : 18 Question Id : 70819118771 Question Type : MCQ Option Shuffling : Yes**

**Is Question Mandatory : No**

**Correct Marks : 4 Wrong Marks : 1**

For extrinsic semiconductors; when doping level is increased;

**Options :**

70819161479. Fermi-level of p-type semiconductor will go upward and Fermi-level of n-type semiconductors will go downward.

70819161480. Fermi-level of p-type semiconductors will go downward and Fermi-level of n-type semiconductor will go upward.

70819161481. Fermi-level of p and n-type semiconductors will not be affected.

70819161482. Fermi-level of both p-type and n-type semiconductors will go upward for  $T > T_F$  K and downward for  $T < T_F$  K, where  $T_F$  is Fermi temperature.

Question Number : 19 Question Id : 70819118772 Question Type : MCQ Option Shuffling : Yes

Is Question Mandatory : No

Correct Marks : 4 Wrong Marks : 1

Match List I with List II.

- | List I          | List II  |
|-----------------|--|
| (a) Rectifier   | (i) Used either for stepping up or stepping down the a.c. voltage                        |
| (b) Stabilizer  | (ii) Used to convert a.c. voltage into d.c. voltage                                      |
| (c) Transformer | (iii) Used to remove any ripple in the rectified output voltage                          |
| (d) Filter      | (iv) Used for constant output voltage even when the input voltage or load current change |

Choose the correct answer from the options given below :

Options :

70819161483. (a)-(ii), (b)-(i), (c)-(iii), (d)-(iv)

70819161484. (a)-(ii), (b)-(iv), (c)-(i), (d)-(iii)

70819161485. (a)-(ii), (b)-(i), (c)-(iv), (d)-(iii)

70819161486. (a)-(iii), (b)-(iv), (c)-(i), (d)-(ii)

Question Number : 20 Question Id : 70819118773 Question Type : MCQ Option Shuffling : Yes

Is Question Mandatory : No

Correct Marks : 4 Wrong Marks : 1

The truth table for the following logic circuit is :

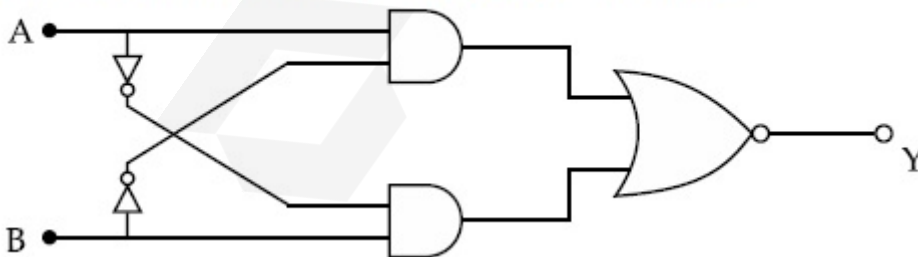

Options :

70819161487.

A	B	Y
0	0	0
0	1	1
1	0	1
1	1	0

A	B	Y
0	0	1
0	1	0
1	0	0
1	1	1

70819161488.

A	B	Y
0	0	1
0	1	0
1	0	1
1	1	0

70819161489.

A	B	Y
0	0	0
0	1	1
1	0	0
1	1	1

70819161490.

## Physics Section B

Section Id :

708191791

Section Number :

2

Section type :	Online
Mandatory or Optional :	Mandatory
Number of Questions :	10
Number of Questions to be attempted :	5
Section Marks :	20
Mark As Answered Required? :	Yes
Sub-Section Number :	1
Sub-Section Id :	7081911071
Question Shuffling Allowed :	Yes

**Question Number : 21 Question Id : 70819118774 Question Type : SA**

**Correct Marks : 4 Wrong Marks : 0**

Two particles having masses 4 g and 16 g respectively are moving with equal kinetic energies. The ratio of the magnitudes of their linear momentum is  $n : 2$ . The value of  $n$  will be \_\_\_\_\_.

**Response Type :** Numeric

**Evaluation Required For SA :** Yes

**Show Word Count :** Yes

**Answers Type :** Range

**Text Areas :** PlainText

**Possible Answers :**

5 to 5.001

**Question Number : 22 Question Id : 70819118775 Question Type : SA**

**Correct Marks : 4 Wrong Marks : 0**

The initial velocity  $v_i$  required to project a body vertically upward from the surface of the earth to reach a height of  $10R$ , where  $R$  is the radius of the earth, may be described in terms

of escape velocity  $v_e$  such that  $v_i = \sqrt{\frac{x}{y}} \times v_e$ . The value of  $x$  will be \_\_\_\_\_.

**Response Type :** Numeric

**Evaluation Required For SA :** Yes

**Show Word Count :** Yes

**Answers Type :** Range

**Text Areas :** PlainText

**Possible Answers :**

5 to 5.001

**Question Number : 23 Question Id : 70819118776 Question Type : SA**

**Correct Marks : 4 Wrong Marks : 0**

The percentage increase in the speed of transverse waves produced in a stretched string if the tension is increased by 4%, will be \_\_\_\_\_%.

**Response Type :** Numeric

**Evaluation Required For SA :** Yes

**Show Word Count :** Yes

**Answers Type :** Range

**Text Areas :** PlainText

**Possible Answers :**

5 to 5.001

**Question Number : 24 Question Id : 70819118777 Question Type : SA**

**Correct Marks : 4 Wrong Marks : 0**

If  $\vec{P} \times \vec{Q} = \vec{Q} \times \vec{P}$ , the angle between  $\vec{P}$  and  $\vec{Q}$  is  $\theta$  ( $0^\circ < \theta < 360^\circ$ ). The value of ' $\theta$ ' will be \_\_\_\_\_°.

**Response Type :** Numeric

**Evaluation Required For SA :** Yes

**Show Word Count :** Yes

**Answers Type :** Range

**Text Areas :** PlainText

**Possible Answers :**

5 to 5.001

**Question Number : 25 Question Id : 70819118778 Question Type : SA**

**Correct Marks : 4 Wrong Marks : 0**

A reversible heat engine converts one-fourth of the heat input into work. When the temperature of the sink is reduced by 52 K, its efficiency is doubled. The temperature in Kelvin of the source will be \_\_\_\_\_.

**Response Type :** Numeric

**Evaluation Required For SA :** Yes

**Show Word Count :** Yes

**Answers Type :** Range

**Text Areas :** PlainText

**Possible Answers :**

5 to 5.001

**Question Number : 26 Question Id : 70819118779 Question Type : SA**

**Correct Marks : 4 Wrong Marks : 0**

Two small spheres each of mass 10 mg are suspended from a point by threads 0.5 m long. They are equally charged and repel each other to a distance of 0.20 m. The charge on each of

the sphere is  $\frac{a}{21} \times 10^{-8}$  C. The value of 'a' will be \_\_\_\_\_.

[Given  $g = 10 \text{ ms}^{-2}$ ]

**Response Type :** Numeric

**Evaluation Required For SA :** Yes

**Show Word Count :** Yes

**Answers Type :** Range

**Text Areas :** PlainText

**Possible Answers :**

5 to 5.001

**Question Number : 27 Question Id : 70819118780 Question Type : SA**

**Correct Marks : 4 Wrong Marks : 0**

Two identical conducting spheres with negligible volume have 2.1 nC and  $-0.5$  nC charges, respectively. They are brought into contact and then separated by a distance of 0.5 m. The electrostatic force acting between the spheres is \_\_\_\_\_  $\times 10^{-9}$  N.

[Given :  $4\pi\epsilon_0 = \frac{1}{9 \times 10^9}$  SI unit]

**Response Type :** Numeric

**Evaluation Required For SA :** Yes

**Show Word Count :** Yes

**Answers Type :** Range

**Text Areas :** PlainText

**Possible Answers :**

5 to 5.001

**Question Number :** 28 **Question Id :** 70819118781 **Question Type :** SA

**Correct Marks :** 4 **Wrong Marks :** 0

The peak electric field produced by the radiation coming from the 8 W bulb at a distance of

10 m is  $\frac{x}{10} \sqrt{\frac{\mu_0 c}{\pi}} \frac{V}{m}$ . The efficiency of the bulb is 10% and it is a point source. The value of  $x$  is \_\_\_\_\_.

**Response Type :** Numeric

**Evaluation Required For SA :** Yes

**Show Word Count :** Yes

**Answers Type :** Range

**Text Areas :** PlainText

**Possible Answers :**

5 to 5.001

**Question Number :** 29 **Question Id :** 70819118782 **Question Type :** SA

**Correct Marks :** 4 **Wrong Marks :** 0

A current of 6 A enters one corner P of an equilateral triangle PQR having 3 wires of resistance  $2\ \Omega$  each and leaves by the corner R. The currents  $i_1$  in ampere is \_\_\_\_\_.

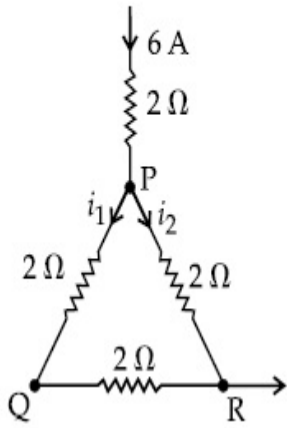

**Response Type :** Numeric

**Evaluation Required For SA :** Yes

**Show Word Count :** Yes

**Answers Type :** Range

**Text Areas :** PlainText

**Possible Answers :**

5 to 5.001

**Question Number :** 30 **Question Id :** 70819118783 **Question Type :** SA

**Correct Marks :** 4 **Wrong Marks :** 0

The wavelength of an X-ray beam is  $10\ \text{\AA}$ . The mass of a fictitious particle having the same energy as that of the X-ray photons is  $\frac{x}{3}h$  kg. The value of  $x$  is \_\_\_\_\_.  
( $h$  = Planck's constant)

**Response Type :** Numeric

**Evaluation Required For SA :** Yes

**Show Word Count :** Yes

**Answers Type :** Range

**Text Areas :** PlainText

**Possible Answers :**

5 to 5.001

Section Id :	708191792
Section Number :	3
Section type :	Online
Mandatory or Optional :	Mandatory
Number of Questions :	20
Number of Questions to be attempted :	20
Section Marks :	80
Mark As Answered Required? :	Yes
Sub-Section Number :	1
Sub-Section Id :	7081911072
Question Shuffling Allowed :	Yes

Question Number : 31 Question Id : 70819118784 Question Type : MCQ Option Shuffling : Yes

Is Question Mandatory : No

Correct Marks : 4 Wrong Marks : 1

Which among the following species has unequal bond lengths ?

Options :

70819161501.  $\text{XeF}_4$

70819161502.  $\text{SiF}_4$

70819161503.  $\text{SF}_4$

70819161504.  $\text{BF}_4^-$

Question Number : 32 Question Id : 70819118785 Question Type : MCQ Option Shuffling : Yes

Is Question Mandatory : No

**Correct Marks : 4 Wrong Marks : 1**

The solubility of  $\text{Ca}(\text{OH})_2$  in water is :

[Given : The solubility product of  $\text{Ca}(\text{OH})_2$  in water =  $5.5 \times 10^{-6}$ ]

**Options :**

70819161505.  $1.11 \times 10^{-2}$

70819161506.  $1.11 \times 10^{-6}$

70819161507.  $1.77 \times 10^{-2}$

70819161508.  $1.77 \times 10^{-6}$

**Question Number : 33 Question Id : 70819118786 Question Type : MCQ Option Shuffling : Yes**

**Is Question Mandatory : No**

**Correct Marks : 4 Wrong Marks : 1**

Which one of the following statements is FALSE for hydrophilic sols ?

**Options :**

70819161509. They do not require electrolytes for stability.

70819161510. These sols are reversible in nature.

70819161511. Their viscosity is of the order of that of  $\text{H}_2\text{O}$ .

70819161512. The sols cannot be easily coagulated.

**Question Number : 34 Question Id : 70819118787 Question Type : MCQ Option Shuffling : Yes**

**Is Question Mandatory : No**

**Correct Marks : 4 Wrong Marks : 1**

The correct order of bond dissociation enthalpy of halogens is :

**Options :**

70819161513.  $F_2 > Cl_2 > Br_2 > I_2$

70819161514.  $I_2 > Br_2 > Cl_2 > F_2$

70819161515.  $Cl_2 > Br_2 > F_2 > I_2$

70819161516.  $Cl_2 > F_2 > Br_2 > I_2$

**Question Number : 35 Question Id : 70819118788 Question Type : MCQ Option Shuffling : Yes**

**Is Question Mandatory : No**

**Correct Marks : 4 Wrong Marks : 1**

The method used for the purification of Indium is :

**Options :**

70819161517. van Arkel method

70819161518. liquation

70819161519. zone refining

70819161520. vapour phase refining

**Question Number : 36 Question Id : 70819118789 Question Type : MCQ Option Shuffling : Yes**

**Is Question Mandatory : No**

**Correct Marks : 4 Wrong Marks : 1**

Water does not produce CO on reacting with :

**Options :**

70819161521.  $CH_4$

70819161522. C

70819161523. CO<sub>2</sub>

70819161524. C<sub>3</sub>H<sub>8</sub>

**Question Number : 37 Question Id : 70819118790 Question Type : MCQ Option Shuffling : Yes**

**Is Question Mandatory : No**

**Correct Marks : 4 Wrong Marks : 1**

Given below are two statements :

Statement I :

$\alpha$  and  $\beta$  forms of sulphur can change reversibly between themselves with slow heating or slow cooling.

Statement II :

At room temperature the stable crystalline form of sulphur is monoclinic sulphur.

In the light of the above statements, choose the correct answer from the options given below :

**Options :**

70819161525. Both Statement I and Statement II are true.

70819161526. Both Statement I and Statement II are false.

70819161527. Statement I is true but Statement II is false.

70819161528. Statement I is false but Statement II is true.

**Question Number : 38 Question Id : 70819118791 Question Type : MCQ Option Shuffling : Yes**

**Is Question Mandatory : No**

**Correct Marks : 4 Wrong Marks : 1**

The major components of German Silver are :

**Options :**

70819161529. Cu, Zn and Ag

70819161530. Cu, Zn and Ni

70819161531. Ge, Cu and Ag

70819161532. Zn, Ni and Ag

**Question Number : 39 Question Id : 70819118792 Question Type : MCQ Option Shuffling : Yes**

**Is Question Mandatory : No**

**Correct Marks : 4 Wrong Marks : 1**

In which of the following order the given complex ions are arranged correctly with respect to their decreasing spin only magnetic moment ?

(i)  $[\text{FeF}_6]^{3-}$  (ii)  $[\text{Co}(\text{NH}_3)_6]^{3+}$  (iii)  $[\text{NiCl}_4]^{2-}$  (iv)  $[\text{Cu}(\text{NH}_3)_4]^{2+}$

**Options :**

70819161533. (i) > (iii) > (iv) > (ii)

70819161534. (ii) > (iii) > (i) > (iv)

70819161535. (iii) > (iv) > (ii) > (i)

70819161536. (ii) > (i) > (iii) > (iv)

**Question Number : 40 Question Id : 70819118793 Question Type : MCQ Option Shuffling : Yes**

**Is Question Mandatory : No**

**Correct Marks : 4 Wrong Marks : 1**

Given below are two statements :

**Statement I :**

The pH of rain water is normally ~5.6.

**Statement II :**

If the pH of rain water drops below 5.6, it is called acid rain.

In the light of the above statements, choose the correct answer from the options given below :

**Options :**

70819161537. Both Statement I and Statement II are true.

70819161538. Both Statement I and Statement II are false.

70819161539. Statement I is true but Statement II is false.

70819161540. Statement I is false but Statement II is true.

**Question Number : 41 Question Id : 70819118794 Question Type : MCQ Option Shuffling : Yes**

**Is Question Mandatory : No**

**Correct Marks : 4 Wrong Marks : 1**

Which of the following compound is added to the sodium extract before addition of silver nitrate for testing of halogens ?

**Options :**

70819161541. Hydrochloric acid

70819161542. Sodium hydroxide

70819161543. Nitric acid

70819161544. Ammonia

**Question Number : 42 Question Id : 70819118795 Question Type : MCQ Option Shuffling : Yes**

Is Question Mandatory : No

Correct Marks : 4 Wrong Marks : 1

The major product of the following reaction is :

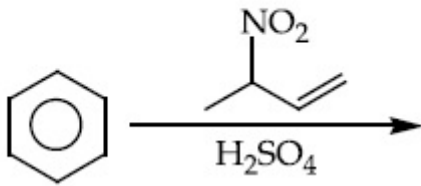

Options :

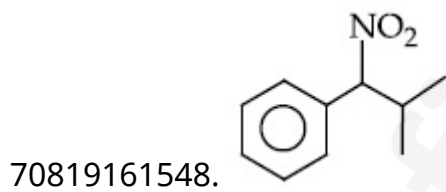
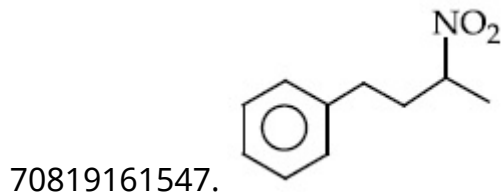
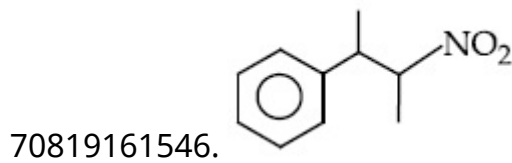
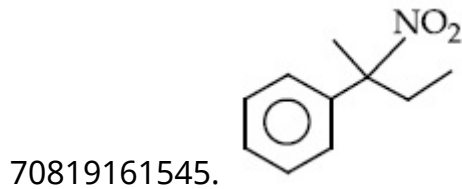

Question Number : 43 Question Id : 70819118796 Question Type : MCQ Option Shuffling : Yes

Is Question Mandatory : No

Correct Marks : 4 Wrong Marks : 1

The major product of the following reaction is :

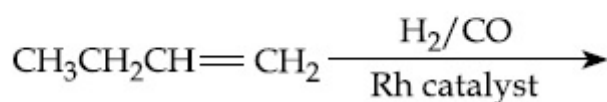

Options :

70819161549.  $\text{CH}_3\text{CH}_2\text{CH}_2\text{CH}_2\text{CHO}$

70819161550.  $\text{CH}_3\text{CH}_2\text{CH}_2\text{CHO}$

70819161551.  $\text{CH}_3\text{CH}_2\text{CH}=\text{CH}-\text{CHO}$

70819161552. 
$$\begin{array}{c} \text{CH}_3\text{CH}_2\text{C}=\text{CH}_2 \\ | \\ \text{CHO} \end{array}$$

**Question Number : 44 Question Id : 70819118797 Question Type : MCQ Option Shuffling : Yes**

**Is Question Mandatory : No**

**Correct Marks : 4 Wrong Marks : 1**

The correct sequence of reagents used in the preparation of 4-bromo-2-nitroethyl benzene from benzene is :

**Options :**

70819161553.  $\text{CH}_3\text{COCl}/\text{AlCl}_3, \text{Br}_2/\text{AlBr}_3, \text{HNO}_3/\text{H}_2\text{SO}_4, \text{Zn}/\text{HCl}$

70819161554.  $\text{CH}_3\text{COCl}/\text{AlCl}_3, \text{Zn-Hg}/\text{HCl}, \text{Br}_2/\text{AlBr}_3, \text{HNO}_3/\text{H}_2\text{SO}_4$

70819161555.  $\text{Br}_2/\text{AlBr}_3, \text{CH}_3\text{COCl}/\text{AlCl}_3, \text{HNO}_3/\text{H}_2\text{SO}_4, \text{Zn}/\text{HCl}$

70819161556.  $\text{HNO}_3/\text{H}_2\text{SO}_4, \text{Br}_2/\text{AlCl}_3, \text{CH}_3\text{COCl}/\text{AlCl}_3, \text{Zn-Hg}/\text{HCl}$

**Question Number : 45 Question Id : 70819118798 Question Type : MCQ Option Shuffling : Yes**

**Is Question Mandatory : No**

**Correct Marks : 4 Wrong Marks : 1**

The correct order of acid character of the following compounds:

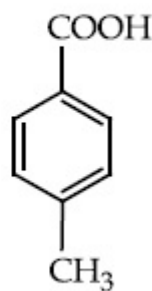
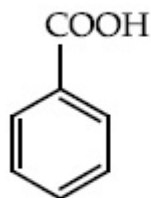
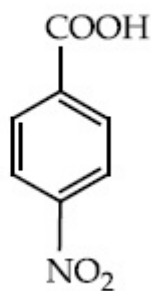
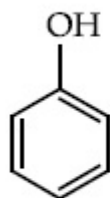

Options :

70819161557. I > II > III > IV

70819161558. III > II > I > IV

70819161559. II > III > IV > I

70819161560. IV > III > II > I

Question Number : 46 Question Id : 70819118799 Question Type : MCQ Option Shuffling : Yes

Is Question Mandatory : No

Correct Marks : 4 Wrong Marks : 1

What is 'X' in the given reaction ?

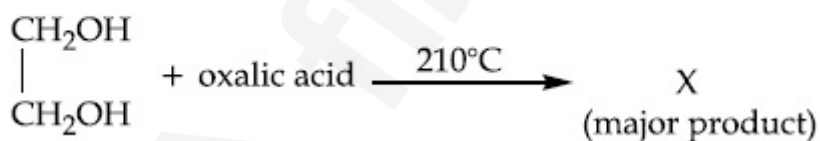

Options :

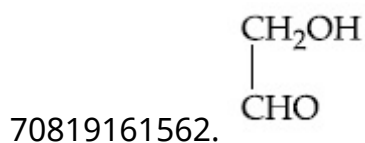
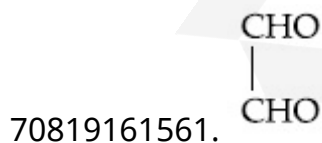

70819161563.

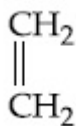

70819161564.

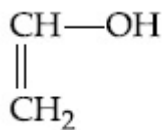

Question Number : 47 Question Id : 70819118800 Question Type : MCQ Option Shuffling : Yes

Is Question Mandatory : No

Correct Marks : 4 Wrong Marks : 1

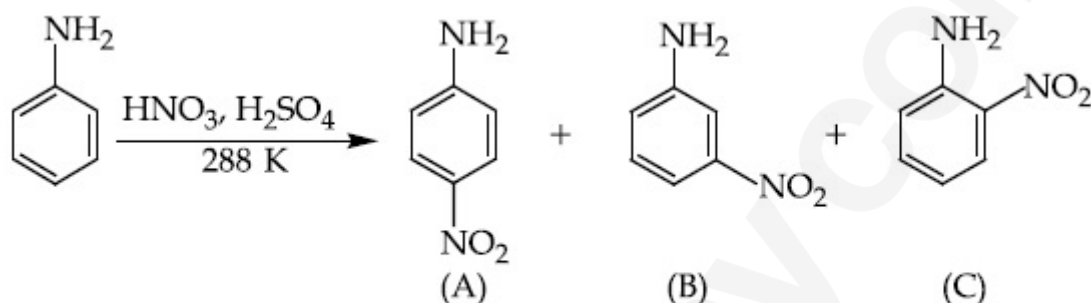

Correct statement about the given chemical reaction is :

Options :

70819161565.  $\text{—}\ddot{\text{N}}\text{H}_2$  group is *ortho* and *para* directive, so product (B) is not possible.

70819161566. Reaction is possible and compound (B) will be the major product.

70819161567. The reaction will form sulphonated product instead of nitration.

70819161568. Reaction is possible and compound (A) will be major product.

Question Number : 48 Question Id : 70819118801 Question Type : MCQ Option Shuffling : Yes

Is Question Mandatory : No

Correct Marks : 4 Wrong Marks : 1

Carbylamine test is used to detect the presence of primary amino group in organic compound. Which of the following compound is formed when this test is performed with aniline ?

Options :

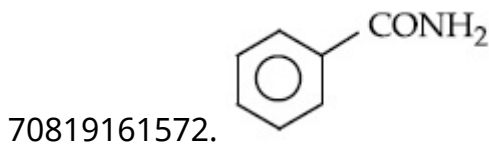
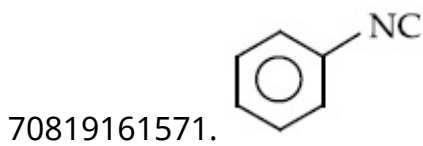
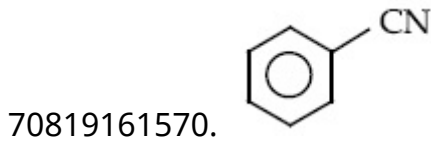
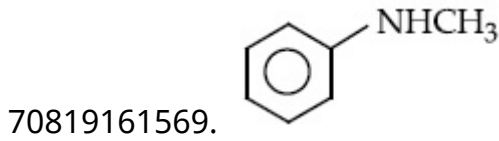

Question Number : 49 Question Id : 70819118802 Question Type : MCQ Option Shuffling : Yes

Is Question Mandatory : No

Correct Marks : 4 Wrong Marks : 1

Which of the following is correct structure of  $\alpha$ -anomer of maltose ?

Options :

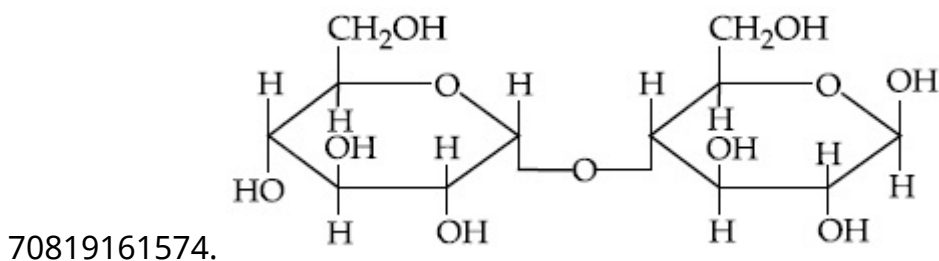
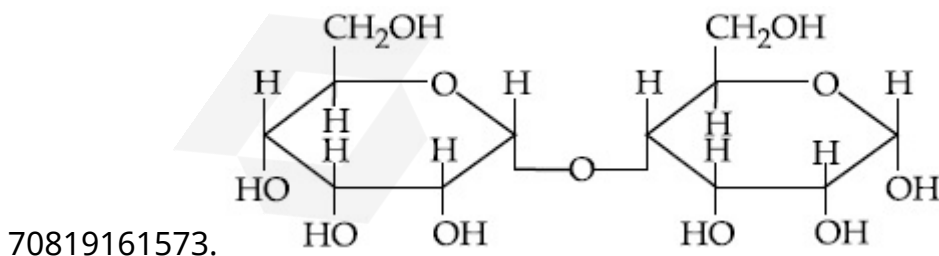

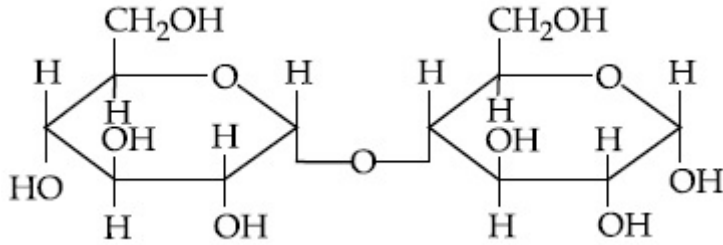

70819161575.

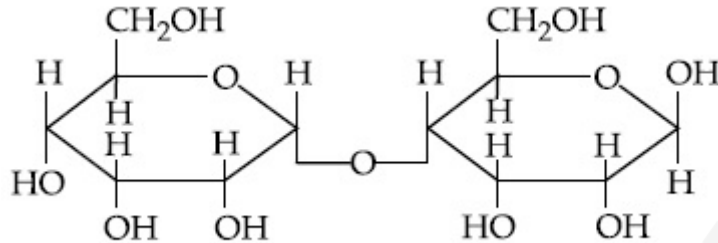

70819161576.

**Question Number : 50 Question Id : 70819118803 Question Type : MCQ Option Shuffling : Yes**

**Is Question Mandatory : No**

**Correct Marks : 4 Wrong Marks : 1**

Given below are two statements :

**Statement I :**

The identification of  $\text{Ni}^{2+}$  is carried out by dimethyl glyoxime in the presence of  $\text{NH}_4\text{OH}$ .

**Statement II :**

The dimethyl glyoxime is a bidentate neutral ligand.

In the light of the above statements, choose the correct answer from the options given below :

**Options :**

70819161577. Both Statement I and Statement II are true.

70819161578. Both Statement I and Statement II are false.

70819161579. Statement I is true but Statement II is false.

70819161580. Statement I is false but Statement II is true.

Section Id :	708191793
Section Number :	4
Section type :	Online
Mandatory or Optional :	Mandatory
Number of Questions :	10
Number of Questions to be attempted :	5
Section Marks :	20
Mark As Answered Required? :	Yes
Sub-Section Number :	1
Sub-Section Id :	7081911073
Question Shuffling Allowed :	Yes

**Question Number : 51 Question Id : 70819118804 Question Type : SA**

**Correct Marks : 4 Wrong Marks : 0**

Consider titration of NaOH solution versus 1.25 M oxalic acid solution. At the end point following burette readings were obtained.

- |             |             |              |
|-------------|-------------|--------------|
| (i) 4.5 mL  | (ii) 4.5 mL | (iii) 4.4 mL |
| (iv) 4.4 mL | (v) 4.4 mL  |              |

If the volume of oxalic acid taken was 10.0 mL then the molarity of the NaOH solution is \_\_\_\_\_ M. (Rounded-off to the nearest integer)

**Response Type : Numeric**

**Evaluation Required For SA : Yes**

**Show Word Count : Yes**

**Answers Type : Range**

**Text Areas : PlainText**

**Possible Answers :**

5 to 5.001

**Question Number : 52 Question Id : 70819118805 Question Type : SA**

**Correct Marks : 4 Wrong Marks : 0**

The unit cell of copper corresponds to a face centered cube of edge length 354 pm with one copper atom at each lattice point. The calculated density of copper in  $\text{kg/m}^3$  is \_\_\_\_\_.

[Molar mass of Cu : 63.54 g ; Avogadro Number =  $6.022 \times 10^{23}$ ]

**Response Type :** Numeric

**Evaluation Required For SA :** Yes

**Show Word Count :** Yes

**Answers Type :** Range

**Text Areas :** PlainText

**Possible Answers :**

5 to 5.001

**Question Number :** 53 **Question Id :** 70819118806 **Question Type :** SA

**Correct Marks :** 4 **Wrong Marks :** 0

Electromagnetic radiation of wavelength 663 nm is just sufficient to ionise the atom of metal A. The ionization energy of metal A in  $\text{kJ mol}^{-1}$  is \_\_\_\_\_. (Rounded-off to the nearest integer)

[ $h = 6.63 \times 10^{-34} \text{ Js}$ ,  $c = 3.00 \times 10^8 \text{ ms}^{-1}$ ,  $N_A = 6.02 \times 10^{23} \text{ mol}^{-1}$ ]

**Response Type :** Numeric

**Evaluation Required For SA :** Yes

**Show Word Count :** Yes

**Answers Type :** Range

**Text Areas :** PlainText

**Possible Answers :**

5 to 5.001

**Question Number :** 54 **Question Id :** 70819118807 **Question Type :** SA

**Correct Marks :** 4 **Wrong Marks :** 0

Five moles of an ideal gas at 293 K is expanded isothermally from an initial pressure of 2.1 MPa to 1.3 MPa against at constant external pressure 4.3 MPa. The heat transferred in this process is \_\_\_\_\_  $\text{kJ mol}^{-1}$ . (Rounded-off to the nearest integer)

[Use  $R = 8.314 \text{ J mol}^{-1} \text{ K}^{-1}$ ]

**Response Type :** Numeric

**Evaluation Required For SA :** Yes

Show Word Count : Yes

Answers Type : Range

Text Areas : PlainText

Possible Answers :

5 to 5.001

Question Number : 55 Question Id : 70819118808 Question Type : SA

Correct Marks : 4 Wrong Marks : 0

If a compound AB dissociates to the extent of 75% in an aqueous solution, the molality of the solution which shows a 2.5 K rise in the boiling point of the solution is \_\_\_\_\_ molal. (Rounded-off to the nearest integer)

$[K_b = 0.52 \text{ K kg mol}^{-1}]$

Response Type : Numeric

Evaluation Required For SA : Yes

Show Word Count : Yes

Answers Type : Range

Text Areas : PlainText

Possible Answers :

5 to 5.001

Question Number : 56 Question Id : 70819118809 Question Type : SA

Correct Marks : 4 Wrong Marks : 0

Copper reduces  $\text{NO}_3^-$  into NO and  $\text{NO}_2$  depending upon the concentration of  $\text{HNO}_3$  in solution. (Assuming fixed  $[\text{Cu}^{2+}]$  and  $P_{\text{NO}} = P_{\text{NO}_2}$ ), the  $\text{HNO}_3$  concentration at which the thermodynamic tendency for reduction of  $\text{NO}_3^-$  into NO and  $\text{NO}_2$  by copper is same is  $10^x \text{ M}$ . The value of  $2x$  is \_\_\_\_\_. (Rounded-off to the nearest integer)

[Given,  $E_{\text{Cu}^{2+}/\text{Cu}}^0 = 0.34 \text{ V}$ ,  $E_{\text{NO}_3^-/\text{NO}}^0 = 0.96 \text{ V}$ ,  $E_{\text{NO}_3^-/\text{NO}_2}^0 = 0.79 \text{ V}$  and at 298 K,

$\frac{RT}{F} (2.303) = 0.059]$

Response Type : Numeric

Evaluation Required For SA : Yes

Show Word Count : Yes

**Answers Type :** Range

**Text Areas :** PlainText

**Possible Answers :**

5 to 5.001

**Question Number : 57 Question Id : 70819118810 Question Type : SA**

**Correct Marks : 4 Wrong Marks : 0**

The rate constant of a reaction increases by five times on increase in temperature from 27°C to 52°C. The value of activation energy in  $\text{kJ mol}^{-1}$  is \_\_\_\_\_. (Rounded-off to the nearest integer)

[ $R = 8.314 \text{ J K}^{-1} \text{ mol}^{-1}$ ]

**Response Type :** Numeric

**Evaluation Required For SA :** Yes

**Show Word Count :** Yes

**Answers Type :** Range

**Text Areas :** PlainText

**Possible Answers :**

5 to 5.001

**Question Number : 58 Question Id : 70819118811 Question Type : SA**

**Correct Marks : 4 Wrong Marks : 0**

Among the following, number of metal/s which can be used as electrodes in the photoelectric cell is \_\_\_\_\_. (Integer answer)

(A) Li                      (B) Na                      (C) Rb                      (D) Cs

**Response Type :** Numeric

**Evaluation Required For SA :** Yes

**Show Word Count :** Yes

**Answers Type :** Range

**Text Areas :** PlainText

**Possible Answers :**

5 to 5.001

Question Number : 59 Question Id : 70819118812 Question Type : SA

Correct Marks : 4 Wrong Marks : 0

The spin only magnetic moment of a divalent ion in aqueous solution (atomic number 29) is \_\_\_\_\_ BM.

Response Type : Numeric

Evaluation Required For SA : Yes

Show Word Count : Yes

Answers Type : Range

Text Areas : PlainText

Possible Answers :

5 to 5.001

Question Number : 60 Question Id : 70819118813 Question Type : SA

Correct Marks : 4 Wrong Marks : 0

The number of compound/s given below which contain/s —COOH group is \_\_\_\_\_.  
(Integer answer)

- |                      |                   |
|----------------------|-------------------|
| (A) Sulphanilic acid | (B) Picric acid   |
| (C) Aspirin          | (D) Ascorbic acid |

Response Type : Numeric

Evaluation Required For SA : Yes

Show Word Count : Yes

Answers Type : Range

Text Areas : PlainText

Possible Answers :

5 to 5.001

## Mathematics Section A

Section Id : 708191794

Section Number : 5

Section type : Online

Mandatory or Optional :	Mandatory
Number of Questions :	20
Number of Questions to be attempted :	20
Section Marks :	80
Mark As Answered Required? :	Yes
Sub-Section Number :	1
Sub-Section Id :	7081911074
Question Shuffling Allowed :	Yes

Question Number : 61 Question Id : 70819118814 Question Type : MCQ Option Shuffling : Yes

Is Question Mandatory : No

Correct Marks : 4 Wrong Marks : 1

If for the matrix,  $A = \begin{bmatrix} 1 & -\alpha \\ \alpha & \beta \end{bmatrix}$ ,  $AA^T = I_2$ , then the value of  $\alpha^4 + \beta^4$  is :

Options :

70819161591. 4

70819161592. 1

70819161593. 2

70819161594. 3

Question Number : 62 Question Id : 70819118815 Question Type : MCQ Option Shuffling : Yes

Is Question Mandatory : No

Correct Marks : 4 Wrong Marks : 1

Let A be a  $3 \times 3$  matrix with  $\det(A) = 4$ . Let  $R_i$  denote the  $i^{\text{th}}$  row of A. If a matrix B is obtained by performing the operation  $R_2 \rightarrow 2R_2 + 5R_3$  on 2A, then  $\det(B)$  is equal to :

Options :

70819161595. 16

70819161596. 80

70819161597. 64

70819161598. 128

**Question Number : 63 Question Id : 70819118816 Question Type : MCQ Option Shuffling : Yes**

**Is Question Mandatory : No**

**Correct Marks : 4 Wrong Marks : 1**

The following system of linear equations

$$2x + 3y + 2z = 9$$

$$3x + 2y + 2z = 9$$

$$x - y + 4z = 8$$

**Options :**

70819161599. does not have any solution

70819161600. has a unique solution

70819161601. has infinitely many solutions

70819161602. has a solution  $(\alpha, \beta, \gamma)$  satisfying  $\alpha + \beta^2 + \gamma^3 = 12$

**Question Number : 64 Question Id : 70819118817 Question Type : MCQ Option Shuffling : Yes**

**Is Question Mandatory : No**

**Correct Marks : 4 Wrong Marks : 1**

If  $I_n = \int_{\frac{\pi}{4}}^{\frac{\pi}{2}} \cot^n x \, dx$ , then :

Options :

70819161603.  $\frac{1}{I_2 + I_4}, \frac{1}{I_3 + I_5}, \frac{1}{I_4 + I_6}$  are in A.P.

70819161604.  $I_2 + I_4, I_3 + I_5, I_4 + I_6$  are in A.P.

70819161605.  $\frac{1}{I_2 + I_4}, \frac{1}{I_3 + I_5}, \frac{1}{I_4 + I_6}$  are in G.P.

70819161606.  $I_2 + I_4, (I_3 + I_5)^2, I_4 + I_6$  are in G.P.

Question Number : 65 Question Id : 70819118818 Question Type : MCQ Option Shuffling : Yes

Is Question Mandatory : No

Correct Marks : 4 Wrong Marks : 1

A function  $f(x)$  is given by  $f(x) = \frac{5^x}{5^x + 5}$ , then the sum of the series

$$f\left(\frac{1}{20}\right) + f\left(\frac{2}{20}\right) + f\left(\frac{3}{20}\right) + \dots + f\left(\frac{39}{20}\right)$$

is equal to :

Options :

70819161607.  $\frac{29}{2}$

70819161608.  $\frac{49}{2}$

70819161609.  $\frac{39}{2}$

70819161610.  $\frac{19}{2}$

Question Number : 66 Question Id : 70819118819 Question Type : MCQ Option Shuffling : Yes  
Is Question Mandatory : No

Correct Marks : 4 Wrong Marks : 1

Let  $\alpha$  and  $\beta$  be the roots of  $x^2 - 6x - 2 = 0$ . If  $a_n = \alpha^n - \beta^n$  for  $n \geq 1$ , then the value of  $\frac{a_{10} - 2a_8}{3a_9}$

is :

Options :

70819161611. 4

70819161612. 3

70819161613. 2

70819161614. 1

Question Number : 67 Question Id : 70819118820 Question Type : MCQ Option Shuffling : Yes  
Is Question Mandatory : No

Correct Marks : 4 Wrong Marks : 1

The minimum value of  $f(x) = a^{a^x} + a^{1-a^x}$ , where  $a, x \in \mathbb{R}$  and  $a > 0$ , is equal to :

Options :

70819161615.  $a + 1$

70819161616.  $a + \frac{1}{a}$

70819161617.  $2\sqrt{a}$

**Question Number : 68 Question Id : 70819118821 Question Type : MCQ Option Shuffling : Yes  
Is Question Mandatory : No**

**Correct Marks : 4 Wrong Marks : 1**

The integral  $\int \frac{e^{3\log_e 2x} + 5e^{2\log_e 2x}}{e^{4\log_e x} + 5e^{3\log_e x} - 7e^{2\log_e x}} dx, x > 0$ , is equal to :

(where c is a constant of integration)

**Options :**

70819161619.  $\log_e |x^2 + 5x - 7| + c$

70819161620.  $4\log_e |x^2 + 5x - 7| + c$

70819161621.  $\frac{1}{4}\log_e |x^2 + 5x - 7| + c$

70819161622.  $\log_e \sqrt{x^2 + 5x - 7} + c$

**Question Number : 69 Question Id : 70819118822 Question Type : MCQ Option Shuffling : Yes  
Is Question Mandatory : No**

**Correct Marks : 4 Wrong Marks : 1**

If  $\alpha, \beta \in \mathbb{R}$  are such that  $1 - 2i$  (here  $i^2 = -1$ ) is a root of  $z^2 + \alpha z + \beta = 0$ , then  $(\alpha - \beta)$  is equal to :

**Options :**

70819161623. 3

70819161624. -3

70819161625. 7

70819161626. -7

**Question Number : 70 Question Id : 70819118823 Question Type : MCQ Option Shuffling : Yes  
Is Question Mandatory : No**

**Correct Marks : 4 Wrong Marks : 1**

If the curve  $x^2 + 2y^2 = 2$  intersects the line  $x + y = 1$  at two points P and Q, then the angle subtended by the line segment PQ at the origin is :

**Options :**

70819161627.  $\frac{\pi}{2} + \tan^{-1}\left(\frac{1}{4}\right)$

70819161628.  $\frac{\pi}{2} - \tan^{-1}\left(\frac{1}{4}\right)$

70819161629.  $\frac{\pi}{2} + \tan^{-1}\left(\frac{1}{3}\right)$

70819161630.  $\frac{\pi}{2} - \tan^{-1}\left(\frac{1}{3}\right)$

**Question Number : 71 Question Id : 70819118824 Question Type : MCQ Option Shuffling : Yes  
Is Question Mandatory : No**

**Correct Marks : 4 Wrong Marks : 1**

The shortest distance between the line  $x - y = 1$  and the curve  $x^2 = 2y$  is :

**Options :**

70819161631.

$$\frac{1}{\sqrt{2}}$$

70819161632.  $\frac{1}{2\sqrt{2}}$

70819161633. 0

70819161634.  $\frac{1}{2}$

**Question Number : 72 Question Id : 70819118825 Question Type : MCQ Option Shuffling : Yes  
Is Question Mandatory : No**

**Correct Marks : 4 Wrong Marks : 1**

A hyperbola passes through the foci of the ellipse  $\frac{x^2}{25} + \frac{y^2}{16} = 1$  and its transverse and conjugate axes coincide with major and minor axes of the ellipse, respectively. If the product of their eccentricities is one, then the equation of the hyperbola is :

**Options :**

70819161635.  $\frac{x^2}{9} - \frac{y^2}{16} = 1$

70819161636.  $\frac{x^2}{9} - \frac{y^2}{4} = 1$

70819161637.  $\frac{x^2}{9} - \frac{y^2}{25} = 1$

70819161638.  $x^2 - y^2 = 9$

Question Number : 73 Question Id : 70819118826 Question Type : MCQ Option Shuffling : Yes

Is Question Mandatory : No

Correct Marks : 4 Wrong Marks : 1

A plane passes through the points A(1, 2, 3), B(2, 3, 1) and C(2, 4, 2). If O is the origin and P is (2, -1, 1), then the projection of  $\vec{OP}$  on this plane is of length :

Options :

70819161639.  $\sqrt{\frac{2}{3}}$

70819161640.  $\sqrt{\frac{2}{11}}$

70819161641.  $\sqrt{\frac{2}{7}}$

70819161642.  $\sqrt{\frac{2}{5}}$

Question Number : 74 Question Id : 70819118827 Question Type : MCQ Option Shuffling : Yes

Is Question Mandatory : No

Correct Marks : 4 Wrong Marks : 1

$\lim_{n \rightarrow \infty} \left[ \frac{1}{n} + \frac{n}{(n+1)^2} + \frac{n}{(n+2)^2} + \dots + \frac{n}{(2n-1)^2} \right]$  is equal to :

Options :

70819161643. 1

70819161644.  $\frac{1}{2}$

70819161645.  $\frac{1}{3}$

70819161646.  $\frac{1}{4}$

**Question Number : 75 Question Id : 70819118828 Question Type : MCQ Option Shuffling : Yes**

**Is Question Mandatory : No**

**Correct Marks : 4 Wrong Marks : 1**

In a group of 400 people, 160 are smokers and non-vegetarian; 100 are smokers and vegetarian and the remaining 140 are non-smokers and vegetarian. Their chances of getting a particular chest disorder are 35%, 20% and 10% respectively. A person is chosen from the group at random and is found to be suffering from the chest disorder. The probability that the selected person is a smoker and non-vegetarian is :

**Options :**

70819161647.  $\frac{7}{45}$

70819161648.  $\frac{8}{45}$

70819161649.  $\frac{28}{45}$

70819161650.  $\frac{14}{45}$

**Question Number : 76 Question Id : 70819118829 Question Type : MCQ Option Shuffling : Yes**

**Is Question Mandatory : No**

**Correct Marks : 4 Wrong Marks : 1**

Let A be a set of all 4-digit natural numbers whose exactly one digit is 7. Then the probability that a randomly chosen element of A leaves remainder 2 when divided by 5 is :

Options :

70819161651.  $\frac{1}{5}$

70819161652.  $\frac{2}{9}$

70819161653.  $\frac{97}{297}$

70819161654.  $\frac{122}{297}$

Question Number : 77 Question Id : 70819118830 Question Type : MCQ Option Shuffling : Yes

Is Question Mandatory : No

Correct Marks : 4 Wrong Marks : 1

If  $0 < x, y < \pi$  and  $\cos x + \cos y - \cos(x + y) = \frac{3}{2}$ , then  $\sin x + \cos y$  is equal to :

Options :

70819161655.  $\frac{1}{2}$

70819161656.  $\frac{\sqrt{3}}{2}$

70819161657.  $\frac{1 - \sqrt{3}}{2}$

70819161658.  $\frac{1 + \sqrt{3}}{2}$

Question Number : 78 Question Id : 70819118831 Question Type : MCQ Option Shuffling : Yes

Is Question Mandatory : No

Correct Marks : 4 Wrong Marks : 1

Let  $x$  denote the total number of one-one functions from a set  $A$  with 3 elements to a set  $B$  with 5 elements and  $y$  denote the total number of one-one functions from the set  $A$  to the set  $A \times B$ . Then :

Options :

70819161659.  $2y = 91x$

70819161660.  $2y = 273x$

70819161661.  $y = 91x$

70819161662.  $y = 273x$

Question Number : 79 Question Id : 70819118832 Question Type : MCQ Option Shuffling : Yes

Is Question Mandatory : No

Correct Marks : 4 Wrong Marks : 1

$\operatorname{cosec} \left[ 2 \cot^{-1}(5) + \cos^{-1} \left( \frac{4}{5} \right) \right]$  is equal to :

Options :

70819161663.  $\frac{56}{33}$

70819161664.  $\frac{65}{33}$

70819161665.  $\frac{65}{56}$

70819161666.

**Question Number : 80 Question Id : 70819118833 Question Type : MCQ Option Shuffling : Yes  
Is Question Mandatory : No**

**Correct Marks : 4 Wrong Marks : 1**

The contrapositive of the statement "If you will work, you will earn money" is :

**Options :**

70819161667. To earn money, you need to work

70819161668. You will earn money, if you will not work

70819161669. If you will not earn money, you will not work

70819161670. If you will earn money, you will work

## Mathematics Section B

<b>Section Id :</b>	708191795
<b>Section Number :</b>	6
<b>Section type :</b>	Online
<b>Mandatory or Optional :</b>	Mandatory
<b>Number of Questions :</b>	10
<b>Number of Questions to be attempted :</b>	5
<b>Section Marks :</b>	20
<b>Mark As Answered Required? :</b>	Yes
<b>Sub-Section Number :</b>	1
<b>Sub-Section Id :</b>	7081911075

Question Shuffling Allowed :

Yes

Question Number : 81 Question Id : 70819118834 Question Type : SA

Correct Marks : 4 Wrong Marks : 0

A function  $f$  is defined on  $[-3, 3]$  as

$$f(x) = \begin{cases} \min\{|x|, 2 - x^2\}, & -2 \leq x \leq 2 \\ \lfloor |x| \rfloor & , 2 < |x| \leq 3 \end{cases}$$

where  $\lfloor x \rfloor$  denotes the greatest integer  $\leq x$ . The number of points, where  $f$  is not differentiable in  $(-3, 3)$  is \_\_\_\_\_.

Response Type : Numeric

Evaluation Required For SA : Yes

Show Word Count : Yes

Answers Type : Range

Text Areas : PlainText

Possible Answers :

5 to 5.001

Question Number : 82 Question Id : 70819118835 Question Type : SA

Correct Marks : 4 Wrong Marks : 0

If the curve,  $y=y(x)$  represented by the solution of the differential equation  $(2xy^2 - y)dx + xdy = 0$ , passes through the intersection of the lines,  $2x - 3y = 1$  and  $3x + 2y = 8$ , then  $|y(1)|$  is equal to \_\_\_\_\_.

Response Type : Numeric

Evaluation Required For SA : Yes

Show Word Count : Yes

Answers Type : Range

Text Areas : PlainText

Possible Answers :

5 to 5.001

Question Number : 83 Question Id : 70819118836 Question Type : SA

**Correct Marks : 4 Wrong Marks : 0**

The total number of two digit numbers 'n', such that  $3^n + 7^n$  is a multiple of 10, is \_\_\_\_\_.

**Response Type : Numeric**

**Evaluation Required For SA : Yes**

**Show Word Count : Yes**

**Answers Type : Range**

**Text Areas : PlainText**

**Possible Answers :**

5 to 5.001

**Question Number : 84 Question Id : 70819118837 Question Type : SA**

**Correct Marks : 4 Wrong Marks : 0**

If  $\lim_{x \rightarrow 0} \frac{ax - (e^{4x} - 1)}{ax(e^{4x} - 1)}$  exists and is equal to b, then the value of  $a - 2b$  is \_\_\_\_\_.

**Response Type : Numeric**

**Evaluation Required For SA : Yes**

**Show Word Count : Yes**

**Answers Type : Range**

**Text Areas : PlainText**

**Possible Answers :**

5 to 5.001

**Question Number : 85 Question Id : 70819118838 Question Type : SA**

**Correct Marks : 4 Wrong Marks : 0**

If the curves  $x = y^4$  and  $xy = k$  cut at right angles, then  $(4k)^6$  is equal to \_\_\_\_\_.

**Response Type : Numeric**

**Evaluation Required For SA : Yes**

**Show Word Count : Yes**

**Answers Type : Range**

**Text Areas :** PlainText

**Possible Answers :**

5 to 5.001

**Question Number : 86 Question Id : 70819118839 Question Type : SA**

**Correct Marks : 4 Wrong Marks : 0**

The value of  $\int_{-2}^2 |3x^2 - 3x - 6| dx$  is \_\_\_\_\_.

**Response Type :** Numeric

**Evaluation Required For SA :** Yes

**Show Word Count :** Yes

**Answers Type :** Range

**Text Areas :** PlainText

**Possible Answers :**

5 to 5.001

**Question Number : 87 Question Id : 70819118840 Question Type : SA**

**Correct Marks : 4 Wrong Marks : 0**

If the remainder when  $x$  is divided by 4 is 3, then the remainder when  $(2020 + x)^{2022}$  is divided by 8 is \_\_\_\_\_.

**Response Type :** Numeric

**Evaluation Required For SA :** Yes

**Show Word Count :** Yes

**Answers Type :** Range

**Text Areas :** PlainText

**Possible Answers :**

5 to 5.001

**Question Number : 88 Question Id : 70819118841 Question Type : SA**

**Correct Marks : 4 Wrong Marks : 0**

A line 'l' passing through origin is perpendicular to the lines

$$l_1 : \vec{r} = (3 + t)\hat{i} + (-1 + 2t)\hat{j} + (4 + 2t)\hat{k}$$

$$l_2 : \vec{r} = (3 + 2s)\hat{i} + (3 + 2s)\hat{j} + (2 + s)\hat{k}$$

If the co-ordinates of the point in the first octant on 'l<sub>2</sub>' at a distance of  $\sqrt{17}$  from the point of intersection of 'l' and 'l<sub>1</sub>' are (a, b, c), then 18(a + b + c) is equal to \_\_\_\_\_.

**Response Type :** Numeric

**Evaluation Required For SA :** Yes

**Show Word Count :** Yes

**Answers Type :** Range

**Text Areas :** PlainText

**Possible Answers :**

5 to 5.001

**Question Number :** 89 **Question Id :** 70819118842 **Question Type :** SA

**Correct Marks :** 4 **Wrong Marks :** 0

A line is a common tangent to the circle  $(x - 3)^2 + y^2 = 9$  and the parabola  $y^2 = 4x$ . If the two points of contact (a, b) and (c, d) are distinct and lie in the first quadrant, then 2(a + c) is equal to \_\_\_\_\_.

**Response Type :** Numeric

**Evaluation Required For SA :** Yes

**Show Word Count :** Yes

**Answers Type :** Range

**Text Areas :** PlainText

**Possible Answers :**

5 to 5.001

**Question Number :** 90 **Question Id :** 70819118843 **Question Type :** SA

**Correct Marks :** 4 **Wrong Marks :** 0

Let  $\vec{a} = \hat{i} + \alpha\hat{j} + 3\hat{k}$  and  $\vec{b} = 3\hat{i} - \alpha\hat{j} + \hat{k}$ . If the area of the parallelogram whose adjacent sides are represented by the vectors  $\vec{a}$  and  $\vec{b}$  is  $8\sqrt{3}$  square units, then  $\vec{a} \cdot \vec{b}$  is equal to \_\_\_\_\_.

**Response Type :** Numeric

**Evaluation Required For SA :** Yes

**Show Word Count :** Yes

**Answers Type :** Range

**Text Areas :** PlainText

**Possible Answers :**

5 to 5.001

