

National Testing Agency

Question Paper Name :	B TECH EO 17th March 2021 Shift 1
Subject Name :	B TECH EO
Creation Date :	2021-03-17 15:29:45
Duration :	180
Number of Questions :	90
Total Marks :	300
Display Marks:	Yes

B TECH EO

Group Number :	1
Group Id :	86435132
Group Maximum Duration :	0
Group Minimum Duration :	180
Show Attended Group? :	No
Edit Attended Group? :	No
Break time :	0
Group Marks :	300
Is this Group for Examiner? :	No

Physics Section A

Section Id :	864351187
Section Number :	1
Section type :	Online
Mandatory or Optional :	Mandatory
Number of Questions :	20
Number of Questions to be attempted :	20
Section Marks :	80
Mark As Answered Required? :	Yes
Sub-Section Number :	1
Sub-Section Id :	864351187
Question Shuffling Allowed :	Yes

Question Number : 1 Question Id : 8643512791 Question Type : MCQ Option Shuffling : Yes Is Question Mandatory : No Correct Marks : 4 Wrong Marks : 1

A car accelerates from rest at a constant rate α for some time after which it decelerates at a constant rate β to come to rest. If the total time elapsed is t seconds, the total distance travelled is :

Options :

8643518371. $\frac{2 \alpha \beta}{(\alpha + \beta)} t^2$

8643518372. $\frac{\alpha \beta}{2(\alpha + \beta)} t^2$

8643518373. $\frac{4 \alpha \beta}{(\alpha + \beta)} t^2$

8643518374. $\frac{\alpha \beta}{4(\alpha + \beta)} t^2$

Question Number : 1 Question Id : 8643512791 Question Type : MCQ Option Shuffling : Yes Is Question Mandatory : No

Correct Marks : 4 Wrong Marks : 1

ଗୋଟିଏ କାର ଛିର ଅବସ୍ଥାରୁ ଏକ ନିର୍ଦ୍ଦିଷ୍ଟ ହାର α ରେ କିଛି ସମୟ ପାଇଁ ବେଗକୁ ବୃଦ୍ଧିତ କରେ ଏହାପରେ ଏହା ଏକ ନିର୍ଦ୍ଦିଷ୍ଟ ହାର β ରେ ମନ୍ଦିତ ହୋଇ ଛିର ଅବସ୍ଥାକୁ ଆସିଯାଏ । ଯଦି ବିରୁଦ୍ଧା ମୋଟ ସମୟ t (ସେକେଣ୍ଡ) ହୁଏ, ତେବେ କାରଟି ଅତିକ୍ରମ କରୁଥିବା ଦୂରତା ହେବ :

Options :

8643518371. $\frac{2 \alpha \beta}{(\alpha + \beta)} t^2$

8643518372. $\frac{\alpha \beta}{2(\alpha + \beta)} t^2$

8643518373. $\frac{4 \alpha \beta}{(\alpha + \beta)} t^2$

8643518374. $\frac{\alpha \beta}{4(\alpha + \beta)} t^2$

Question Number : 2 Question Id : 8643512792 Question Type : MCQ Option Shuffling : Yes Is

Question Mandatory : No

Correct Marks : 4 Wrong Marks : 1

A modern grand - prix racing car of mass m is travelling on a flat track in a circular arc of radius R with a speed v . If the coefficient of static friction between the tyres and the track is μ_s , then the magnitude of negative lift F_L acting downwards on the car is : (Assume forces on the four tyres are identical and g = acceleration due to gravity)

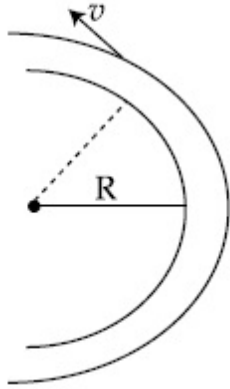

Options :

8643518375. $m \left(\frac{v^2}{\mu_s R} + g \right)$

8643518376. $m \left(g - \frac{v^2}{\mu_s R} \right)$

8643518377. $m \left(\frac{v^2}{\mu_s R} - g \right)$

8643518378. $-m \left(g + \frac{v^2}{\mu_s R} \right)$

Question Number : 2 Question Id : 8643512792 Question Type : MCQ Option Shuffling : Yes Is

Question Mandatory : No

Correct Marks : 4 Wrong Marks : 1

m ବସ୍ତୁର ଥିବା ଗୋଟିଏ ଆଧୁନିକ ଗ୍ରାଣ୍ଟ-ପ୍ରିକ୍ସ ଦୌଡ଼ କାର R ବ୍ୟାସାର୍ଦ୍ଧ ବିଶିଷ୍ଟ ଏକ ବୃତ୍ତାକାର ଚାପରେ ରହିଥିବା ଗୋଟିଏ ଟେକା ପଥ (ଫ୍ଲ୍‌ର ଟ୍ରାକ୍) ରେ v ବେଗରେ ଗତି କରୁଅଛି । ଯଦି ଟାୟାର ଏବଂ ଟ୍ରାକ୍ ମଧ୍ୟରେ ସ୍ଥିର ଘର୍ଷଣ ଧ୍ରୁବୀକ μ_s ରହୁଛି, ତେବେ କାରଟି ଉପରେ ନିମ୍ନଗାମୀ କାମ କରୁଥିବା ରଣାତ୍ମକ ଲିଫ୍ଟ୍, F_L ହେଉଛି :

(ଧରିନିଅ ଯେ ଟାୟାର ଟାୟାର ଉପରେ ପଡୁଥିବା ବଳଗୁଡ଼ିକ ସମାନ ଏବଂ $g =$ ମାଧ୍ୟାକର୍ଷଣ ଜନିତ ଦୂରଣ)

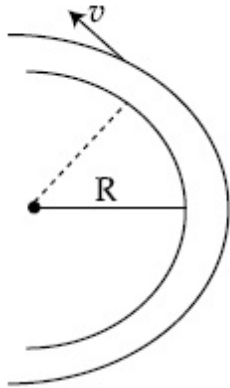

Options :

8643518375. $m \left(\frac{v^2}{\mu_s R} + g \right)$

8643518376. $m \left(g - \frac{v^2}{\mu_s R} \right)$

8643518377. $m \left(\frac{v^2}{\mu_s R} - g \right)$

8643518378. $- m \left(g + \frac{v^2}{\mu_s R} \right)$

Question Number : 3 Question Id : 8643512793 Question Type : MCQ Option Shuffling : Yes Is Question Mandatory : No

Correct Marks : 4 Wrong Marks : 1

A Carnot's engine working between 400 K and 800 K has a work output of 1200 J per cycle. The amount of heat energy supplied to the engine from the source in each cycle is :

Options :

8643518379. 2400 J

8643518380. 1600 J

8643518381. 3200 J

8643518382. 1800 J

Question Number : 3 Question Id : 8643512793 Question Type : MCQ Option Shuffling : Yes Is Question Mandatory : No

Correct Marks : 4 Wrong Marks : 1

400 K ଏବଂ 800 K ମଧ୍ୟରେ କାର୍ଯ୍ୟ କରୁଥିବା ଏକ କାରନଟ୍ ଇଞ୍ଜିନ୍ ପ୍ରତି ଚକ୍ର (ସାଇକେଲ) 1200 J ପରିମାଣର କାର୍ଯ୍ୟ ସମ୍ପାଦନ କରିଥାଏ । ପ୍ରତ୍ୟେକ ସାଇକେଲରେ ଉତ୍ସର୍ଗିତ ଇଞ୍ଜିନ୍‌କୁ ଯୋଗାଇ ଦିଆଯାଉଥିବା ତାପଶକ୍ତିର ପରିମାଣ ହେବ :

Options :

8643518379. 2400 J

8643518380. 1600 J

8643518381. 3200 J

8643518382. 1800 J

Question Number : 4 Question Id : 8643512794 Question Type : MCQ Option Shuffling : Yes Is Question Mandatory : No

Correct Marks : 4 Wrong Marks : 1

A solenoid of 1000 turns per metre has a core with relative permeability 500. Insulated windings of the solenoid carry an electric current of 5 A. The magnetic flux density produced by the solenoid is : (permeability of free space = $4\pi \times 10^{-7}$ H/m)

Options :

8643518383. $10^{-4}\pi$ T8643518384. $2 \times 10^{-3}\pi$ T8643518385. $\frac{\pi}{5}$ T8643518386. π T

Question Number : 4 Question Id : 8643512794 Question Type : MCQ Option Shuffling : Yes Is

Question Mandatory : No

Correct Marks : 4 Wrong Marks : 1

ମିଟର ପ୍ରତି 1000 ଘେରା ଥିବା ଏକ ସଲିନିଏଡର 500 ଆପେକ୍ଷିକ ବିଦ୍ୟୁତ୍‌ଶୀଳତା ଥିବା ଏକ କୋର୍ ଅଛି । ସଲିନିଏଡର ବିଦ୍ୟୁତ୍ ପ୍ରତିରୋଧିତ ତାରଗୁଡ଼ା ମଧ୍ୟରେ 5 A ର ବିଦ୍ୟୁତ୍ ସ୍ରୋତ ପ୍ରବାହିତ ହେଉଅଛି । ସଲିନିଏଡର ଦ୍ଵାରା ଉତ୍ପନ୍ନ ଚୁମ୍ବକୀୟ ଫ୍ଲୁ ସାନ୍ଦ୍ରତା ହେଉଛି :

(ଶୂନ୍ୟର ପାରଗମ୍ୟତା = $4\pi \times 10^{-7}$ H/m)

Options :

8643518383. $10^{-4}\pi$ T

8643518384. $2 \times 10^{-3}\pi$ T

8643518385. $\frac{\pi}{5}$ T

8643518386. π T

Question Number : 5 Question Id : 8643512795 Question Type : MCQ Option Shuffling : Yes Is

Question Mandatory : No

Correct Marks : 4 Wrong Marks : 1

A current of 10 A exists in a wire of crosssectional area of 5 mm² with a drift velocity of 2×10^{-3} ms⁻¹. The number of free electrons in each cubic meter of the wire is _____.

Options :

8643518387. 2×10^6

8643518388. 1×10^{23}

8643518389. 625×10^{25}

8643518390. 2×10^{25}

Question Number : 5 Question Id : 8643512795 Question Type : MCQ Option Shuffling : Yes Is

Question Mandatory : No

Correct Marks : 4 Wrong Marks : 1

ଚଳନ ପରିବେଗ (ଦ୍ରୁତ, ଭେଲୋସିଟି) $2 \times 10^{-3} \text{ ms}^{-1}$ ସହ ଗୋଟିଏ 5 mm^2 ପ୍ରସ୍ଥଚ୍ଛେଦ କ୍ଷେତ୍ରଫଳ ବିଶିଷ୍ଟ ଏକ ତାରରେ 10 A ର ବିଦ୍ୟୁତ୍ ସ୍ରୋତ ପ୍ରବାହିତ ହେଉଅଛି । ତାରଟିର ପ୍ରତି ଘନମିଟର ଆୟତନରେ ରହୁଥିବା ମୁକ୍ତ ଇଲେକ୍ଟ୍ରନ୍ ସଂଖ୍ୟା ଅଟେ _____ ।

Options :

8643518387. 2×10^6

8643518388. 1×10^{23}

8643518389. 625×10^{25}

8643518390. 2×10^{25}

Question Number : 6 Question Id : 8643512796 Question Type : MCQ Option Shuffling : Yes Is

Question Mandatory : No

Correct Marks : 4 Wrong Marks : 1

A mass M hangs on a massless rod of length l which rotates at a constant angular frequency. The mass M moves with steady speed in a circular path of constant radius. Assume that the system is in steady circular motion with constant angular velocity ω . The angular momentum of M about point A is L_A which lies in the positive z direction and the angular momentum of M about point B is L_B . The correct statement for this system is :

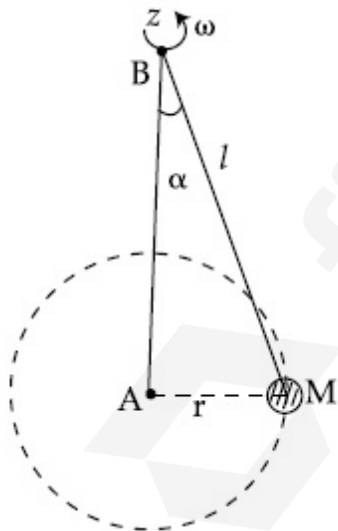

Options :

8643518391. L_A and L_B are both constant in magnitude and direction

8643518392. L_A is constant, both in magnitude and direction

8643518393. L_B is constant, both in magnitude and direction

8643518394. L_B is constant in direction with varying magnitude

Question Number : 6 Question Id : 8643512796 Question Type : MCQ Option Shuffling : Yes Is Question Mandatory : No

Correct Marks : 4 Wrong Marks : 1

ବସ୍ତୁଦ୍ୱିଧାନ l ଦୈର୍ଘ୍ୟ ବିଶିଷ୍ଟ ଗୋଟିଏ ରତ୍ନରୁ ଏକ ବସ୍ତୁ M ଝୁଲୁଛି ଯାହା ଏକ ସ୍ଥିର କୌଣିକ ଆବୃତ୍ତିରେ ଘୂରୁଅଛି । ବସ୍ତୁ M ଠି ଏକ ନିର୍ଦ୍ଦିଷ୍ଟ ବ୍ୟାସାର୍ଦ୍ଧ ବିଶିଷ୍ଟ ଗୋଟିଏ ବୃତ୍ତାକାର ପଥରେ ସ୍ଥିର ବେଗରେ ଗତି କରୁଛି । ଧରିନିଅ ଯେ, ଏହି ସିଷ୍ଟମ୍ ଠି ଏକ ସ୍ଥିର କୌଣିକ ପରିବେଗରେ ସ୍ଥିର ବୃତ୍ତାକାର ଗତିରେ ଗତି କରୁଛି । ବିନ୍ଦୁ A O ଠିରେ କୌଣିକ ସଂବେଗ L_A , ଯାହା ଯୁକ୍ତାତ୍ମକ z ଦିଗରେ ରହିଥାଏ ଏବଂ B ବିନ୍ଦୁରେ କୌଣିକ ସଂବେଗ M ହେଉଛି L_B । ଏହି ସିଷ୍ଟମ୍ ପାଇଁ ସଠିକ୍ ଉକ୍ତିଟି ଅଟେ :

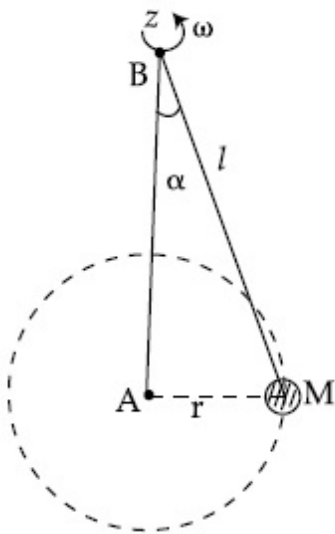

Options :

8643518391. ଉଭୟ L_A ଏବଂ L_B ର ସ୍ଥିର ମାପକ ଏବଂ ଦିଗ ରହିଛି ।

8643518392. L_A ର ଉଭୟ ମାପକ ଓ ଦିଗ ସ୍ଥିର ରହିଛି ।

8643518393. L_B ର ଉଭୟ ମାପକ ଓ ଦିଗ ସ୍ଥିର ରହିଛି ।

8643518394. L_B ଦିଗ ସ୍ଥିର ସହ ପରାବର୍ତ୍ତନୀୟ ମାପକ ରହିଛି ।

Question Number : 7 Question Id : 8643512797 Question Type : MCQ Option Shuffling : Yes Is Question Mandatory : No

Correct Marks : 4 Wrong Marks : 1

An AC current is given by $I = I_1 \sin \omega t + I_2 \cos \omega t$. A hot wire ammeter will give a reading :

Options :

8643518395. $\frac{I_1 + I_2}{\sqrt{2}}$

8643518396. $\frac{I_1 + I_2}{2\sqrt{2}}$

8643518397. $\sqrt{\frac{I_1^2 + I_2^2}{2}}$

8643518398. $\sqrt{\frac{I_1^2 - I_2^2}{2}}$

Question Number : 7 Question Id : 8643512797 Question Type : MCQ Option Shuffling : Yes Is Question Mandatory : No

Correct Marks : 4 Wrong Marks : 1

ଗୋଟିଏ ପ୍ରତ୍ୟାବର୍ତ୍ତୀ ବିଦ୍ୟୁତ୍ ସ୍ରୋତକୁ $I = I_1 \sin \omega t + I_2 \cos \omega t$ ଦ୍ୱାରା ଦିଆଯାଇଛି । ଗୋଟିଏ ହର୍ ଓୟାର ଆମିଟର ଦର୍ଶାଉଥିବା ପଠନ (ରିଡିଂ) ହେବ :

Options :

8643518395. $\frac{I_1 + I_2}{\sqrt{2}}$

8643518396. $\frac{I_1 + I_2}{2\sqrt{2}}$

8643518397. $\sqrt{\frac{I_1^2 + I_2^2}{2}}$

8643518398. $\sqrt{\frac{I_1^2 - I_2^2}{2}}$

Question Number : 8 Question Id : 8643512798 Question Type : MCQ Option Shuffling : Yes Is Question Mandatory : No

Correct Marks : 4 Wrong Marks : 1

A polyatomic ideal gas has 24 vibrational modes. What is the value of γ ?

Options :

8643518399. 10.3

8643518400. 1.30

8643518401. 1.03

8643518402. 1.37

Question Number : 8 Question Id : 8643512798 Question Type : MCQ Option Shuffling : Yes Is Question Mandatory : No

Correct Marks : 4 Wrong Marks : 1

ଗୋଟିଏ ବହୁ ପରମାଣୁ ବିଶିଷ୍ଟ ଆଦର୍ଶ ଗ୍ୟାସର 24 ଟି କମ୍ପନ ମୋଡ୍ γ ଅଛି । γ ର ମୂଲ୍ୟ କେତେ ହେବ ?

Options :

8643518399. 10.3

8643518400. 1.30

8643518401. 1.03

8643518402. 1.37

Question Number : 9 Question Id : 8643512799 Question Type : MCQ Option Shuffling : Yes Is Question Mandatory : No

Correct Marks : 4 Wrong Marks : 1

When two soap bubbles of radii a and b ($b > a$) coalesce, the radius of curvature of common surface is :

Options :

8643518403. $\frac{ab}{b-a}$ 8643518404. $\frac{ab}{a+b}$ 8643518405. $\frac{b-a}{ab}$

$$8643518406. \quad \frac{a+b}{ab}$$

Question Number : 9 Question Id : 8643512799 Question Type : MCQ Option Shuffling : Yes Is Question Mandatory : No

Correct Marks : 4 Wrong Marks : 1

ଯେତେବେଳେ a ଏବଂ b ($b > a$) ବ୍ୟାସାର୍ଦ୍ଧ ବିଶିଷ୍ଟ ଦୁଇଟି ସାଦୃଶ ପାଣି ଫୋଟକା ପରସ୍ପର ସହ ଯୋଡ଼ି ହୋଇ ରହନ୍ତି, ସେମାନଙ୍କର ସାଧାରଣ ବକ୍ରପୃଷ୍ଠର ବ୍ୟାସାର୍ଦ୍ଧ ହେବ :

Options :

$$8643518403. \quad \frac{ab}{b-a}$$

$$8643518404. \quad \frac{ab}{a+b}$$

$$8643518405. \quad \frac{b-a}{ab}$$

$$8643518406. \quad \frac{a+b}{ab}$$

Question Number : 10 Question Id : 8643512800 Question Type : MCQ Option Shuffling : Yes Is Question Mandatory : No

Correct Marks : 4 Wrong Marks : 1

A triangular plate is shown. A force $\vec{F} = 4\hat{i} - 3\hat{j}$ is applied at point P. The torque at point

P with respect to point 'O' and 'Q' are :

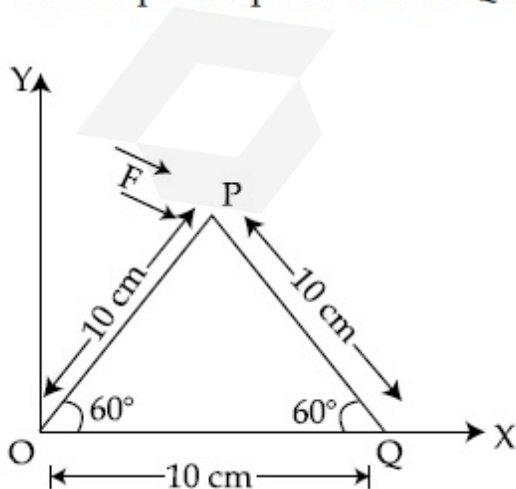

Options :

8643518407. $-15 - 20\sqrt{3}, 15 - 20\sqrt{3}$

8643518408. $15 + 20\sqrt{3}, 15 - 20\sqrt{3}$

8643518409. $15 - 20\sqrt{3}, 15 + 20\sqrt{3}$

8643518410. $-15 + 20\sqrt{3}, 15 + 20\sqrt{3}$

Question Number : 10 Question Id : 8643512800 Question Type : MCQ Option Shuffling : Yes Is Question Mandatory : No

Correct Marks : 4 Wrong Marks : 1

ଗୋଟିଏ ତ୍ରିକୋଣୀ ପ୍ଲେଟ୍ ଦର୍ଶାଯାଇଅଛି । ଗୋଟିଏ ବଳ $\vec{F} = 4\hat{i} - 3\hat{j}$ କୁ P ବିନ୍ଦୁରେ ପ୍ରୟୋଗ କରାଯାଇଛି । P ବିନ୍ଦୁରେ, 'O' ବିନ୍ଦୁ ଓ 'Q' ବିନ୍ଦୁ ଭିତ୍ତିକ ଆକର୍ଷଣ ଯଥାକ୍ରମେ ହେବ :

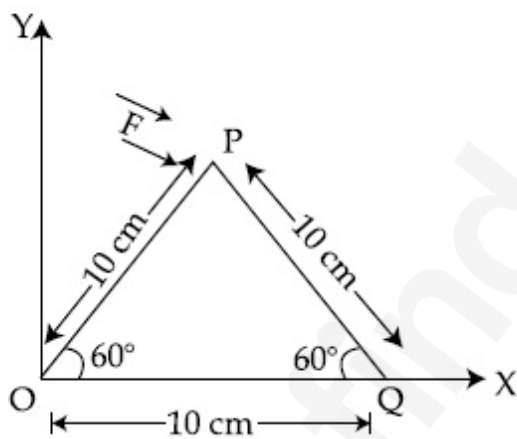

Options :

8643518407. $-15 - 20\sqrt{3}, 15 - 20\sqrt{3}$

8643518408. $15 + 20\sqrt{3}, 15 - 20\sqrt{3}$

8643518409. $15 - 20\sqrt{3}, 15 + 20\sqrt{3}$

8643518410. $-15 + 20\sqrt{3}, 15 + 20\sqrt{3}$

Question Number : 11 Question Id : 8643512801 Question Type : MCQ Option Shuffling : Yes Is

Question Mandatory : No

Correct Marks : 4 Wrong Marks : 1

Two identical metal wires of thermal conductivities K_1 and K_2 respectively are connected in series. The effective thermal conductivity of the combination is :

Options :

8643518411. $\frac{K_1 K_2}{K_1 + K_2}$

8643518412. $\frac{2K_1 K_2}{K_1 + K_2}$

8643518413. $\frac{K_1 + K_2}{2K_1 K_2}$

8643518414. $\frac{K_1 + K_2}{K_1 K_2}$

Question Number : 11 Question Id : 8643512801 Question Type : MCQ Option Shuffling : Yes Is

Question Mandatory : No

Correct Marks : 4 Wrong Marks : 1

ତାପୀୟ ଚାଳକତା ଯଥାକ୍ରମେ K_1 ଏବଂ K_2 ଥିବା ଦୁଇଟି ଏକାପ୍ରକାରର ଧାତବ ତାରକୁ ଶ୍ରେଣୀରେ ସଂଯୋଗ କରାଗଲା । ଏହି ସଂଯୋଗଟିର ପରିଣାମୀ ତାପୀୟ ଚାଳକତା ହେବ :

Options :

8643518411. $\frac{K_1 K_2}{K_1 + K_2}$

8643518412. $\frac{2K_1 K_2}{K_1 + K_2}$

8643518413. $\frac{K_1 + K_2}{2K_1 K_2}$

8643518414. $\frac{K_1 + K_2}{K_1 K_2}$

Question Number : 12 Question Id : 8643512802 Question Type : MCQ Option Shuffling : Yes Is

Question Mandatory : No

Correct Marks : 4 Wrong Marks : 1

A boy is rolling a 0.5 kg ball on the frictionless floor with the speed of 20 ms^{-1} . The ball gets deflected by an obstacle on the way. After deflection it moves with 5% of its initial kinetic energy. What is the speed of the ball now ?

Options :

8643518415. 1.00 ms^{-1}

8643518416. 4.47 ms^{-1}

8643518417. 14.41 ms^{-1}

8643518418. 19.0 ms^{-1}

Question Number : 12 Question Id : 8643512802 Question Type : MCQ Option Shuffling : Yes Is

Question Mandatory : No

Correct Marks : 4 Wrong Marks : 1

ଜଣେ ବାଳକ 0.5 kg ର ଏକ ବଲ୍‌ଟିକୁ ଘର୍ଷଣବିହୀନ ଚଟାଣରେ 20 ms^{-1} ବେଗରେ ଗଡ଼ାଇ ଦେଲା । ବାଟରେ ବଲ୍‌ଟି ଗୋଟିଏ ପ୍ରତିବନ୍ଧ ଦ୍ୱାରା ବାଧାପ୍ରାପ୍ତ ହୋଇ ବିଚ୍ୟୁତି ହେଲା । ବିଚ୍ୟୁତି ପରେ ଏହା ଏହାର ପ୍ରାରମ୍ଭିକ ଗତିଜ ଶକ୍ତିର 5% ସହିତ ଗତି କଲା । ବର୍ତ୍ତମାନ ବଲ୍‌ଟିର ବେଗ କେତେ ହେବ ?

Options :

8643518415. 1.00 ms^{-1}

8643518416. 4.47 ms^{-1}

8643518417. 14.41 ms^{-1}

8643518418. 19.0 ms^{-1}

Question Number : 13 Question Id : 8643512803 Question Type : MCQ Option Shuffling : Yes Is

Question Mandatory : No

Correct Marks : 4 Wrong Marks : 1

The thickness at the centre of a plano convex lens is 3 mm and the diameter is 6 cm. If the speed of light in the material of the lens is $2 \times 10^8 \text{ ms}^{-1}$. The focal length of the lens is _____.

Options :

8643518419. 30 cm

8643518420. 15 cm

8643518421. 1.5 cm

8643518422. 0.30 cm

Question Number : 13 Question Id : 8643512803 Question Type : MCQ Option Shuffling : Yes Is Question Mandatory : No

Correct Marks : 4 Wrong Marks : 1

ଗୋଟିଏ ସମୋତ୍ତଳ (ପ୍ଲାନୋ କନ୍ଭେକ୍ସ) ଯବକାଚର ମୋଟଲ 3 mm ଏବଂ ବ୍ୟାସ 6 cm ଅଟେ । ଯଦି ଯବକାଚ ଗଠିତ ପଦାର୍ଥରେ ଆଲୋକର ଗତି $2 \times 10^8 \text{ ms}^{-1}$ ହୁଏ, ତେବେ ଯବକାଚଟିର ଫୋକସ୍ ବୈର୍ଣ୍ଣ୍ୟ ହେଉଛି _____ ।
(ନିକଟତମ ପୂର୍ଣ୍ଣସଂଖ୍ୟାରେ ପରିଣତ କର)

Options :

8643518419. 30 cm

8643518420. 15 cm

8643518421. 1.5 cm

8643518422. 0.30 cm

Question Number : 14 Question Id : 8643512804 Question Type : MCQ Option Shuffling : Yes Is Question Mandatory : No

Correct Marks : 4 Wrong Marks : 1

Which level of the single ionized carbon has the same energy as the ground state energy of hydrogen atom ?

Options :

8643518423. 1

8643518424. 4

8643518425. 6

8643518426. 8

Question Number : 14 Question Id : 8643512804 Question Type : MCQ Option Shuffling : Yes Is Question Mandatory : No

Correct Marks : 4 Wrong Marks : 1

ଏକକ ଆୟନିକରଣ ହୋଇଥିବା କାର୍ବନ୍ର କେଉଁ ସ୍ତରର ଶକ୍ତିର ପରିମାଣ ହାଇଡ୍ରୋଜେନ୍ ପରମାଣୁର ଗ୍ରାଉଣ୍ଡଷ୍ଟେଟ୍ ଶକ୍ତି ସହ ସମାନ ?

Options :

8643518423. 1

8643518424. 4

8643518425. 6

8643518426. 8

Question Number : 15 Question Id : 8643512805 Question Type : MCQ Option Shuffling : Yes Is Question Mandatory : No

Correct Marks : 4 Wrong Marks : 1

Two ideal polyatomic gases at temperatures T_1 and T_2 are mixed so that there is no loss of energy. If F_1 and F_2 , m_1 and m_2 , n_1 and n_2 be the degrees of freedom, masses, number of molecules of the first and second gas respectively, the temperature of mixture of these two gases is :

Options :

8643518427.
$$\frac{n_1 F_1 T_1 + n_2 F_2 T_2}{n_1 + n_2}$$

8643518428.
$$\frac{n_1 F_1 T_1 + n_2 F_2 T_2}{F_1 + F_2}$$

8643518429.
$$\frac{n_1 F_1 T_1 + n_2 F_2 T_2}{n_1 F_1 + n_2 F_2}$$

8643518430.
$$\frac{n_1 T_1 + n_2 T_2}{n_1 + n_2}$$

Question Number : 15 Question Id : 8643512805 Question Type : MCQ Option Shuffling : Yes Is

Question Mandatory : No

Correct Marks : 4 Wrong Marks : 1

T_1 ଏବଂ T_2 ତାପମାତ୍ରାରେ ଥିବା ଦୁଇଟି ଆଦର୍ଶ ବହୁପରମାଣୁ ବିଶିଷ୍ଟ ଗ୍ୟାସକୁ ମିଶାଗଲା ଯେମିତିକି କିଛି ଶକ୍ତି ଅପତନ ହେଲା ନାହିଁ । ଯଦି ପ୍ରଥମ ଓ ଦ୍ୱିତୀୟ ଗ୍ୟାସର ସ୍ୱାତନ୍ତ୍ର୍ୟ ମାତ୍ରା, ବସ୍ତୁତ୍ୱ ଏବଂ ଅଣୁ ସଂଖ୍ୟା ଯଥାକ୍ରମେ F_1 ଓ F_2 , m_1 ଓ m_2 ଏବଂ n_1 ଓ n_2 ହୁଅନ୍ତି, ତେବେ ଏହି ଦୁଇ ଗ୍ୟାସ ମିଶ୍ରଣର ତାପମାତ୍ରା ଅଟେ :

Options :

8643518427.
$$\frac{n_1 F_1 T_1 + n_2 F_2 T_2}{n_1 + n_2}$$

8643518428.
$$\frac{n_1 F_1 T_1 + n_2 F_2 T_2}{F_1 + F_2}$$

8643518429.
$$\frac{n_1 F_1 T_1 + n_2 F_2 T_2}{n_1 F_1 + n_2 F_2}$$

8643518430.
$$\frac{n_1 T_1 + n_2 T_2}{n_1 + n_2}$$

Question Number : 16 Question Id : 8643512806 Question Type : MCQ Option Shuffling : Yes Is

Question Mandatory : No

Correct Marks : 4 Wrong Marks : 1

For what value of displacement the kinetic energy and potential energy of a simple harmonic oscillation become equal ?

Options :

8643518431. $x = \pm A$

8643518432. $x = 0$

8643518433. $x = \pm \frac{A}{\sqrt{2}}$

8643518434. $x = \frac{A}{2}$

Question Number : 16 Question Id : 8643512806 Question Type : MCQ Option Shuffling : Yes Is

Question Mandatory : No

Correct Marks : 4 Wrong Marks : 1

ବିଶ୍ଳାଷନର କେଉଁ ମୂଲ୍ୟ ପାଇଁ ଏକ ସରଳ ହାରମୋନିକ୍ ଗତିର ସ୍ଥିତିଜ ଶକ୍ତି ଓ ଗତିଜ ଶକ୍ତି ସମାନ ହେବ ?

Options :

8643518431. $x = \pm A$

8643518432. $x = 0$

8643518433. $x = \pm \frac{A}{\sqrt{2}}$

8643518434. $x = \frac{A}{2}$

Question Number : 17 Question Id : 8643512807 Question Type : MCQ Option Shuffling : Yes Is

Question Mandatory : No

Correct Marks : 4 Wrong Marks : 1

The output of the given combination gates represents :

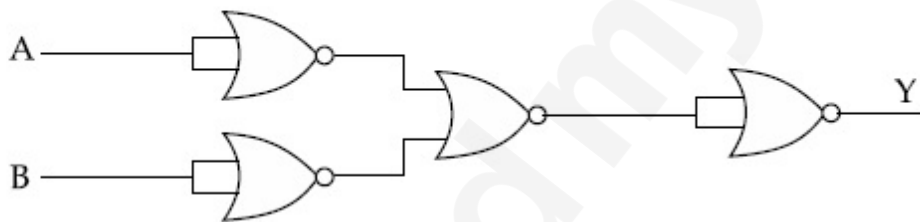

Options :

8643518435. AND Gate

8643518436. NOR Gate

8643518437. NAND Gate

8643518438. XOR Gate

Question Number : 17 Question Id : 8643512807 Question Type : MCQ Option Shuffling : Yes Is

Question Mandatory : No

Correct Marks : 4 Wrong Marks : 1

ଦତ୍ତ ଗେଟ୍‌ଗୁଡ଼ିକ ସଂହତର ନିର୍ଗମ(ଆଉଟପୁଟ) ସୂଚିତ କରେ :

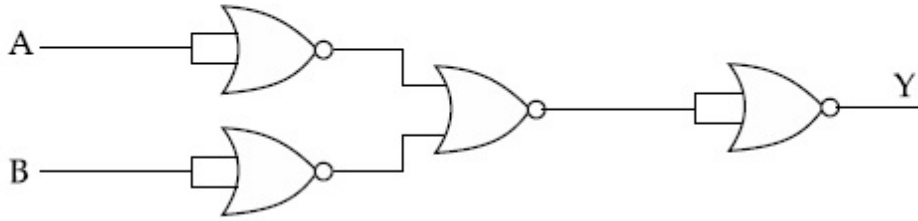

Options :

8643518435. AND ଗେଟ୍
8643518436. NOR ଗେଟ୍
8643518437. NAND ଗେଟ୍
8643518438. XOR ଗେଟ୍

Question Number : 18 Question Id : 8643512808 Question Type : MCQ Option Shuffling : Yes Is Question Mandatory : No

Correct Marks : 4 Wrong Marks : 1

An electron of mass m and a photon have same energy E . The ratio of wavelength of electron to that of photon is : (c being the velocity of light)

Options :

8643518439. $\left(\frac{E}{2m}\right)^{1/2}$
8643518440. $c(2mE)^{1/2}$
8643518441. $\frac{1}{c} \left(\frac{2m}{E}\right)^{1/2}$
8643518442. $\frac{1}{c} \left(\frac{E}{2m}\right)^{1/2}$

Question Number : 18 Question Id : 8643512808 Question Type : MCQ Option Shuffling : Yes Is

Question Mandatory : No

Correct Marks : 4 Wrong Marks : 1

m ବସ୍ତୁର ଥିବା ଏକ ଇଲେକ୍ଟ୍ରନ୍ ଏବଂ ଫୋଟନ୍‌ର ସମାନ ଶକ୍ତି E ରହିଛି । ଇଲେକ୍ଟ୍ରନ୍‌ର ଚରଣ ଦୈର୍ଘ୍ୟ ଓ ଫୋଟନ୍‌ର ଚରଣ ଦୈର୍ଘ୍ୟର ଅନୁପାତ ଅଟେ : (c ହେଉଛି ଆଲୋକର ବେଗ)

Options :

8643518439. $\left(\frac{E}{2m}\right)^{1/2}$

8643518440. $c(2mE)^{1/2}$

8643518441. $\frac{1}{c}\left(\frac{2m}{E}\right)^{1/2}$

8643518442. $\frac{1}{c}\left(\frac{E}{2m}\right)^{1/2}$

Question Number : 19 Question Id : 8643512809 Question Type : MCQ Option Shuffling : Yes Is

Question Mandatory : No

Correct Marks : 4 Wrong Marks : 1

The vernier scale used for measurement has a positive zero error of 0.2 mm. If while taking a measurement it was noted that '0' on the vernier scale lies between 8.5 cm and 8.6 cm, vernier coincidence is 6, then the correct value of measurement is _____ cm. (least count = 0.01 cm)

Options :

8643518443. 8.58 cm

8643518444. 8.56 cm

8643518445. 8.54 cm

8643518446. 8.36 cm

Question Number : 19 Question Id : 8643512809 Question Type : MCQ Option Shuffling : Yes Is

Question Mandatory : No

Correct Marks : 4 Wrong Marks : 1

ମାପପାଇଁ ବ୍ୟବହୃତ ହେଉଥିବା ଗୋଟିଏ ଭରନିୟର ସ୍କେଲର 0.2 mm ର ଏକ ଯୁକ୍ତାତ୍ମକ ଶୂନ୍ୟଙ୍କ ତ୍ରୁଟି ରହିଛି । ଯଦି ମାପ ନେବା ସମୟରେ ଦେଖାଗଲା ଯେ, ଭରନିୟର ସ୍କେଲର '0' 8.5 cm ଏବଂ 8.6 cm ମଧ୍ୟରେ ରହିଲା ଏବଂ ଭରନିୟର ମେଳକ (ଭରନିୟର କ୍ୟାଲିବ୍ରେସନ୍) 6 ଅଟେ, ତେବେ ମାପଟିର ସଠିକ୍ ମୂଲ୍ୟ ହେଉଛି _____ cm ।
(କ୍ଷୁଦ୍ରତମ ମାପ = 0.01 cm)

Options :

8643518443. 8.58 cm

8643518444. 8.56 cm

8643518445. 8.54 cm

8643518446. 8.36 cm

Question Number : 20 Question Id : 8643512810 Question Type : MCQ Option Shuffling : Yes Is Question Mandatory : No

Correct Marks : 4 Wrong Marks : 1

If an electron is moving in the n^{th} orbit of the hydrogen atom, then its velocity (v_n) for the n^{th} orbit is given as :

Options :

8643518447. $v_n \propto n^2$

8643518448. $v_n \propto n$

8643518449. $v_n \propto \frac{1}{n^2}$

8643518450. $v_n \propto \frac{1}{n}$

Question Number : 20 Question Id : 8643512810 Question Type : MCQ Option Shuffling : Yes Is Question Mandatory : No

Correct Marks : 4 Wrong Marks : 1

ଯଦି ଏକ ଇଲେକ୍ଟ୍ରନ୍ ଉଦ୍‌ଘାଜ ପରମାଣୁର n ଡମ୍ କକ୍ଷରେ ଗତି କରୁଅଛି, ତେବେ n ଡମ୍ କକ୍ଷ ପାଇଁ ଏହାର ବେଗ (v_n) କୁ ଦର୍ଶାଯାଇପାରିବ :

Options :

8643518447. $v_n \propto n^2$

8643518448. $v_n \propto n$

8643518449. $v_n \propto \frac{1}{n^2}$

8643518450. $v_n \propto \frac{1}{n}$

Physics Section B

Section Id :	864351188
Section Number :	2
Section type :	Online
Mandatory or Optional :	Mandatory
Number of Questions :	10
Number of Questions to be attempted :	5
Section Marks :	20
Mark As Answered Required? :	Yes
Sub-Section Number :	1
Sub-Section Id :	864351188
Question Shuffling Allowed :	Yes

Question Number : 21 Question Id : 8643512811 Question Type : SA

Correct Marks : 4 Wrong Marks : 0

For VHF signal broadcasting, _____ km² of maximum service area will be covered by an antenna tower of height 30 m, if the receiving antenna is placed at ground. Let radius of the earth be 6400 km. (Round off to the Nearest Integer) (Take π as 3.14)

Response Type : Numeric

Evaluation Required For SA : Yes

Show Word Count : Yes

Answers Type : Equal

Text Areas : PlainText

Possible Answers :

100

Question Number : 21 Question Id : 8643512811 Question Type : SA

Correct Marks : 4 Wrong Marks : 0

ଯଦି ସଂକେତ ଗ୍ରହଣ କରୁଥିବା ଆଣ୍ଟେନା ଉଠି ଉପରେ ଥାଏ, ତେବେ 30 m ଉଚ୍ଚତା ଥିବା ଗୋଟିଏ ଆଣ୍ଟେନା ଗାଡ଼ାର VHF ସଂକେତ ପ୍ରସାରଣ ପାଇଁ ସର୍ବାଧିକ ସେବା ଉପଲବ୍ଧ ଅଞ୍ଚଳ ହେବ _____ km² । (ନିକଟତମ ପୂର୍ଣ୍ଣସଂଖ୍ୟାରେ) । ଧର ପୃଥିବୀର ବ୍ୟାସାର୍ଦ୍ଧ 6400 km । ($\pi = 3.14$ ନିଅ)

Response Type : Numeric

Evaluation Required For SA : Yes

Show Word Count : Yes

Answers Type : Equal

Text Areas : PlainText

Possible Answers :

100

Question Number : 22 **Question Id :** 8643512812 **Question Type :** SA

Correct Marks : 4 **Wrong Marks :** 0

If 2.5×10^{-6} N average force is exerted by a light wave on a non - reflecting surface of 30 cm² area during 40 minutes of time span, the energy flux of light just before it falls on the surface is _____ W/cm². (Round off to the Nearest Integer)

(Assume complete absorption and normal incidence conditions are there)

Response Type : Numeric

Evaluation Required For SA : Yes

Show Word Count : Yes

Answers Type : Equal

Text Areas : PlainText

Possible Answers :

100

Question Number : 22 **Question Id :** 8643512812 **Question Type :** SA

Correct Marks : 4 **Wrong Marks :** 0

ଯଦି ଗୋଟିଏ 30 cm² କ୍ଷେତ୍ରଫଳ ବିଶିଷ୍ଟ ଅପ୍ରତିଫଳନ ପୃଷ୍ଠରେ 40 ମିନିଟ୍ ଧରି ପଡୁଥିବା ଏକ ଆଲୋକ ତରଙ୍ଗ 2.5×10^{-6} N ର ହାରାହାରି ବଳ ପ୍ରୟୋଗ କରେ, ତେବେ ଆଲୋକଟି ପୃଷ୍ଠରେ ଠିକ୍ ପଡ଼ିବା ପୂର୍ବରୁ ଏହାର ଶକ୍ତି ଅବିବାହ (ପୁଞ୍ଜ) ଅଟେ _____ W/cm² । (ନିକଟତମ ପୂର୍ଣ୍ଣସଂଖ୍ୟାରେ)

(ଧରିନିଅ ସେଠାରେ ଆଲୋକର ସଂପୂର୍ଣ୍ଣ ଶୋଷଣ ଏବଂ ଲମ୍ବୀୟ ଆପତନ ସ୍ଥିତି ରହିଛି)

Response Type : Numeric

Evaluation Required For SA : Yes

Show Word Count : Yes

Answers Type : Equal

Text Areas : PlainText

Possible Answers :

100

Question Number : 23 Question Id : 8643512813 Question Type : SA

Correct Marks : 4 Wrong Marks : 0

Four identical rectangular plates with length, $l = 2$ cm and breadth, $b = \frac{3}{2}$ cm are arranged as shown in figure. The equivalent capacitance between A and C is $\frac{x\epsilon_0}{d}$. The value of x is

..... (Round off to the Nearest Integer)

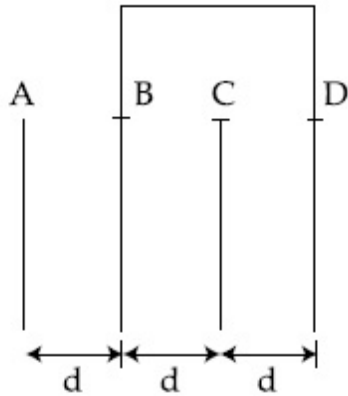

Response Type : Numeric

Evaluation Required For SA : Yes

Show Word Count : Yes

Answers Type : Equal

Text Areas : PlainText

Possible Answers :

100

Question Number : 23 Question Id : 8643512813 Question Type : SA

Correct Marks : 4 Wrong Marks : 0

ଚିତ୍ରରେ ଦର୍ଶାଯାଇଥିବା ଅନୁସାରେ ଦୈର୍ଘ୍ୟ, $l=2$ cm ଏବଂ ପ୍ରସ୍ଥ, $b = \frac{3}{2}$ cm ବିଶିଷ୍ଟ ଚାରୋଟି ଏକାଭଳି ଆୟତକାର

ଘୋଟଗୁଡ଼ିକୁ ସଜାଯାଇଅଛି । A ଏବଂ C ମଧ୍ୟରେ ସମତୁଲ୍ୟ ଧାରିତା $\frac{x\epsilon_0}{d}$ ଅଟେ ।

x ର ମୂଲ୍ୟ ହେବ _____ । (ନିକଟତମ ପୂର୍ଣ୍ଣସଂଖ୍ୟାରେ)

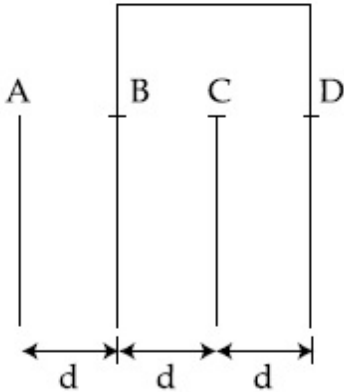

Response Type : Numeric

Evaluation Required For SA : Yes

Show Word Count : Yes

Answers Type : Equal

Text Areas : PlainText

Possible Answers :

100

Question Number : 24 **Question Id :** 8643512814 **Question Type :** SA

Correct Marks : 4 **Wrong Marks :** 0

The equivalent resistance of series combination of two resistors is 's'. When they are connected in parallel, the equivalent resistance is 'p'. If $s=np$, then the minimum value for n is _____ . (Round off to the Nearest Integer)

Response Type : Numeric

Evaluation Required For SA : Yes

Show Word Count : Yes

Answers Type : Equal

Text Areas : PlainText

Possible Answers :

100

Question Number : 24 **Question Id :** 8643512814 **Question Type :** SA

Correct Marks : 4 **Wrong Marks :** 0

ଶ୍ରେଣୀରେ ସଂଯୁକ୍ତ ଦୁଇଟି ପ୍ରତିରୋଧକର ସମତୁଲ୍ୟ ପ୍ରତିରୋଧ 's' ଅଟେ । ଯେତେବେଳେ ସେମାନଙ୍କ ସମାନ୍ତର ଭାବରେ ସଂଯୁକ୍ତ କରାଗଲା, ସମତୁଲ୍ୟ ପ୍ରତିରୋଧ 'p' ହେଲା । ଯଦି $s=np$, n ର ସର୍ବନିମ୍ନ ମୂଲ୍ୟ ହେବ _____ । (ନିକଟତମ ପୂର୍ଣ୍ଣସଂଖ୍ୟାରେ)

Response Type : Numeric

Evaluation Required For SA : Yes

Show Word Count : Yes

Answers Type : Equal

Text Areas : PlainText

Possible Answers :

100

Question Number : 25 Question Id : 8643512815 Question Type : SA

Correct Marks : 4 Wrong Marks : 0

A parallel plate capacitor whose capacitance C is 14 pF is charged by a battery to a potential difference $V = 12 \text{ V}$ between its plates. The charging battery is now disconnected and a porcelain plate with $k = 7$ is inserted between the plates, then the plate would oscillate back and forth between the plates with a constant mechanical energy of _____ pJ .

(Assume no friction)

Response Type : Numeric

Evaluation Required For SA : Yes

Show Word Count : Yes

Answers Type : Equal

Text Areas : PlainText

Possible Answers :

100

Question Number : 25 Question Id : 8643512815 Question Type : SA

Correct Marks : 4 Wrong Marks : 0

14 pF ଧାରିତା ବିଶିଷ୍ଟ ଏକ ସମାନ୍ତର ପ୍ଲେଟ୍ ଧାରିତ୍ରକୁ ଗୋଟିଏ ବ୍ୟାଟେରୀ ଦ୍ୱାରା ଏହାର ପ୍ଲେଟ୍ ମଧ୍ୟରେ ବିଭବ ପାର୍ଥକ୍ୟ $V = 12 \text{ V}$ କୁ ଚାର୍ଜିତ କରାଗଲା । ବର୍ତ୍ତମାନ ଚାର୍ଜ କରୁଥିବା ବ୍ୟାଟେରୀକୁ ବିଚ୍ଛିନ୍ନ କରିଦିଆଗଲା ଏବଂ ପରାବୈଦ୍ୟୁତାଙ୍କ $k = 7$ ଥିବା ଚିନାମାଟି (ପୋରସିଲିନ୍) ପ୍ଲେଟ୍ ଧାରିତା ପ୍ଲେଟ୍ ଦ୍ୱୟ ମଧ୍ୟରେ ଭର୍ତ୍ତି କରାଗଲା, ଏହାପରେ ଉକ୍ତ ପ୍ଲେଟ୍ଟି ଏକ ସ୍ଥିର ଯାନ୍ତ୍ରିକ ଶକ୍ତି _____ pJ ସହ ପ୍ଲେଟ୍ ଦୁଇଟି ମଧ୍ୟରେ ଆଗକୁ ପଛକୁ ହୋଇ ବୋଳାୟମାନ ହେଲା ।

(ଘର୍ଷଣହୀନ ବୋଲି ଧରିନିଅ)

Response Type : Numeric

Evaluation Required For SA : Yes

Show Word Count : Yes

Answers Type : Equal

Text Areas : PlainText

Possible Answers :

100

Question Number : 26 Question Id : 8643512816 Question Type : SA

Correct Marks : 4 Wrong Marks : 0

The radius in kilometer to which the present radius of earth ($R = 6400$ km) to be compressed so that the escape velocity is increased 10 times is _____ .

Response Type : Numeric

Evaluation Required For SA : Yes

Show Word Count : Yes

Answers Type : Equal

Text Areas : PlainText

Possible Answers :

100

Question Number : 26 **Question Id :** 8643512816 **Question Type :** SA

Correct Marks : 4 **Wrong Marks :** 0

ପ୍ରକାଶନ ପରିବେଶକୁ 10 ଗୁଣ ବୃଦ୍ଧି କରିବା ପାଇଁ ବର୍ତ୍ତମାନ ପୃଥିବୀର ବ୍ୟାସାର୍ଦ୍ଧକୁ ($R = 6400$ km) କୁ ସଂକୋଚନ କରି _____ km କରାଯିବା ଆବଶ୍ୟକ ।

Response Type : Numeric

Evaluation Required For SA : Yes

Show Word Count : Yes

Answers Type : Equal

Text Areas : PlainText

Possible Answers :

100

Question Number : 27 **Question Id :** 8643512817 **Question Type :** SA

Correct Marks : 4 **Wrong Marks :** 0

The angular speed of truck wheel is increased from 900 rpm to 2460 rpm in 26 seconds. The number of revolutions by the truck engine during this time is _____ .

(Assuming the acceleration to be uniform).

Response Type : Numeric

Evaluation Required For SA : Yes

Show Word Count : Yes

Answers Type : Equal

Text Areas : PlainText

Possible Answers :

100

Question Number : 27 **Question Id :** 8643512817 **Question Type :** SA

Correct Marks : 4 **Wrong Marks :** 0

ଗୋଟିଏ ଟ୍ରକ୍ ଚକର କୌଣିକ ଦେଗ 26 ସେକେଣ୍ଡରେ 900 rpm ରୁ 2460 rpm କୁ ବଦଳିଲା । ଏହି ସମୟ ମଧ୍ୟରେ ଟ୍ରକ୍ ଚକ ଦ୍ୱାରା ସମ୍ପୂର୍ଣ୍ଣ ହେଉଥିବା ପରିକ୍ରମଣର ସଂଖ୍ୟା ଅଟେ _____।

ତୁରନ୍ତ ସମାନ ବୋଲି ଧର

Response Type : Numeric

Evaluation Required For SA : Yes

Show Word Count : Yes

Answers Type : Equal

Text Areas : PlainText

Possible Answers :

100

Question Number : 28 **Question Id :** 8643512818 **Question Type :** SA

Correct Marks : 4 **Wrong Marks :** 0

Consider two identical springs each of spring constant k and negligible mass compared to the mass M as shown. Fig. 1 shows one of them and Fig. 2 shows their series combination.

The ratios of time period of oscillation of the two SHM is $T_b/T_a = \sqrt{x}$, where value of x is

_____. (Round off to the Nearest Integer)

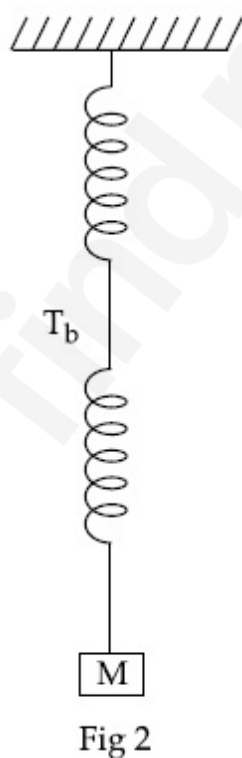
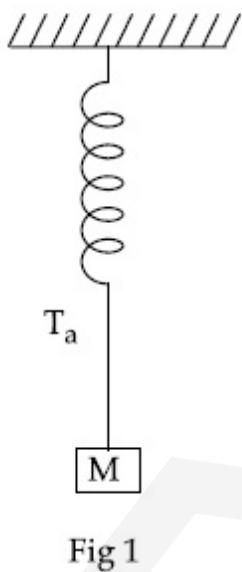

Response Type : Numeric

Evaluation Required For SA : Yes

Show Word Count : Yes

Answers Type : Equal

Text Areas : PlainText

Possible Answers :

100

Question Number : 28 Question Id : 8643512818 Question Type : SA

Correct Marks : 4 Wrong Marks : 0

ଦର୍ଶାଯାଇଥିବା ଅନୁସାରେ M ବସ୍ତୁର ତୁଳନାରେ ଅତି ନଗଣ୍ୟ ବସ୍ତୁ ଏବଂ ସ୍ପ୍ରିଙ୍ଗ୍ ଧ୍ରୁବାଙ୍କ k ଥିବା ଦୁଇଟି ଏକାଭଳିଆ ସ୍ପ୍ରିଙ୍ଗ୍ କୁ ବିଚାରକୁ ନିଅ । ଚିତ୍ର 1 ସେମାନଙ୍କ ମଧ୍ୟରୁ ଗୋଟିକୁ ଦର୍ଶାଉଛି ଏବଂ ଚିତ୍ର 2 ସେମାନଙ୍କର ଶ୍ରେଣୀରେ ସଂଯୋଗକୁ ଦର୍ଶାଉଅଛି ।

ଦୁଇଟି ସରଳ ହାରମୋନିକ୍ ଦୋଳନ (SHM) ର ଆବର୍ତ୍ତକାଳ ଦୁଇଟିର ଅନୁପାତ ହେଉଛି $T_b/T_a = \sqrt{x}$, ଯେଉଁଠାରେ x ର

ମୂଲ୍ୟ ଅଟେ _____ । (ନିକଟତମ ପୂର୍ଣ୍ଣସଂଖ୍ୟାରେ)

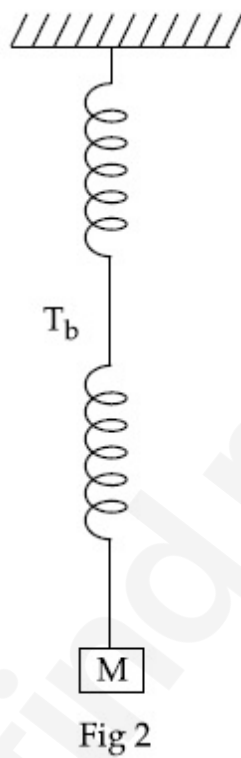
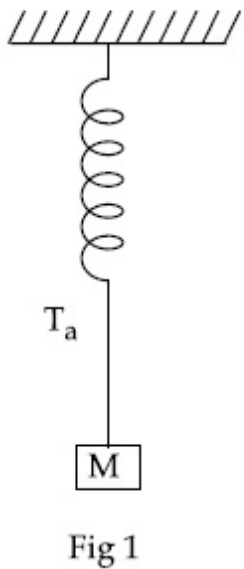

Response Type : Numeric

Evaluation Required For SA : Yes

Show Word Count : Yes

Answers Type : Equal

Text Areas : PlainText

Possible Answers :

100

Question Number : 29 Question Id : 8643512819 Question Type : SA

Correct Marks : 4 Wrong Marks : 0

The following bodies,

- (1) a ring
- (2) a disc
- (3) a solid cylinder
- (4) a solid sphere,

of same mass 'm' and radius 'R' are allowed to roll down without slipping simultaneously from the top of the inclined plane. The body which will reach first at the bottom of the inclined plane is _____.

[Mark the body as per their respective numbering given in the question]

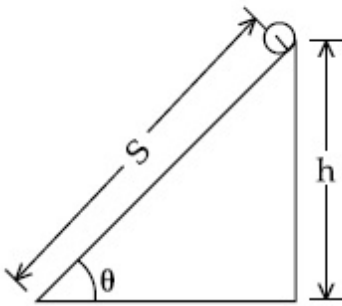

Response Type : Numeric

Evaluation Required For SA : Yes

Show Word Count : Yes

Answers Type : Equal

Text Areas : PlainText

Possible Answers :

100

Question Number : 29 **Question Id :** 8643512819 **Question Type :** SA

Correct Marks : 4 **Wrong Marks :** 0

ସମାନ ବସ୍ତୁ 'm' ଏବଂ ବ୍ୟାସାର୍ଦ୍ଧ 'R' ଥିବା ନିମ୍ନଲିଖିତ ବସ୍ତୁଗୁଡ଼ିକୁ,

- (1) ଗୋଟିଏ ବଳୟ
- (2) ଗୋଟିଏ ଡିସ୍କ
- (3) ଗୋଟିଏ ନିଦା ସିଲିଣ୍ଡର
- (4) ଗୋଟିଏ ନିଦା ଗୋଲକ

ଏକ ସମୟରେ ଗୋଟିଏ ଆନତ ପୃଷ୍ଠର ଶୀର୍ଷରୁ ନିଖସି ଗଢ଼ିଗଢ଼ି ଯିବାପାଇଁ ଦିଆଗଲା । ନିମ୍ନଦେଶରେ ପ୍ରଥମେ ପହଞ୍ଚିଥିବା ବସ୍ତୁଟି ଅଟେ _____ ।

(ବସ୍ତୁଗୁଡ଼ିକୁ ପ୍ରଶ୍ନରେ ଦତ୍ତ ସେମାନଙ୍କର ସୂଚିତାଙ୍କ ଅନୁସାରେ ଚିହ୍ନାଅ)

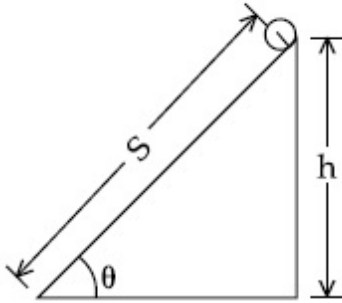

Response Type : Numeric

Evaluation Required For SA : Yes

Show Word Count : Yes

Answers Type : Equal

Text Areas : PlainText

Possible Answers :

100

Question Number : 30 **Question Id :** 8643512820 **Question Type :** SA

Correct Marks : 4 **Wrong Marks :** 0

Two blocks ($m=0.5$ kg and $M=4.5$ kg) are arranged on a horizontal frictionless table as shown in figure. The coefficient of static friction between the two blocks is $\frac{3}{7}$. Then the maximum horizontal force that can be applied on the larger block so that the blocks move together is _____ N. (Round off to the Nearest Integer) [Take g as 9.8 ms⁻²]

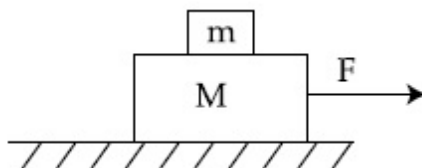

Response Type : Numeric**Evaluation Required For SA :** Yes**Show Word Count :** Yes**Answers Type :** Equal**Text Areas :** PlainText**Possible Answers :**

100

Question Number : 30 **Question Id :** 8643512820 **Question Type :** SA**Correct Marks :** 4 **Wrong Marks :** 0

ଦର୍ଶାଯାଇଥିବା ଅନୁସାରେ ଗୋଟିଏ ଭୂସମାନ୍ତର ଘର୍ଷଣହୀନ ଟେବୁଲ୍ ଉପରେ ଦୁଇଟି ବ୍ଲକ୍ ($m = 0.5 \text{ kg}$ ଏବଂ $M = 4.5 \text{ kg}$)

କୁ ସଜାଯାଇଅଛି । ଦୁଇଟି ବ୍ଲକ୍ ମଧ୍ୟରେ ଛିର ଘର୍ଷଣ ଧୁବାଙ୍କ $\frac{3}{7}$ ଅଟେ । ବ୍ଲକ୍ ଦୁଇଟିକୁ ଏକାସଂଗେ ଗତିଶୀଳ କରାଇବା ପାଇଁ

ବୃହତ୍ତର ବ୍ଲକ୍ ଉପରେ ପକାଯାଇପାରୁଥିବା ସର୍ବାଧିକ ଭୂସମାନ୍ତର ବଳ ଅଟେ _____ N ।

($g = 9.8 \text{ ms}^{-2}$ ନିଅ) (ନିକଟତମ ପୂର୍ଣ୍ଣସଂଖ୍ୟାରେ)

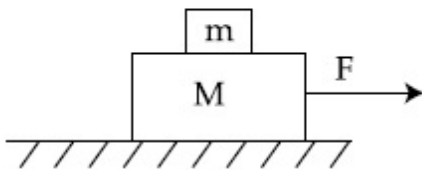
**Response Type :** Numeric**Evaluation Required For SA :** Yes**Show Word Count :** Yes**Answers Type :** Equal**Text Areas :** PlainText**Possible Answers :**

100

Chemistry Section A

Section Id :	864351189
Section Number :	3
Section type :	Online
Mandatory or Optional :	Mandatory
Number of Questions :	20
Number of Questions to be attempted :	20
Section Marks :	80
Mark As Answered Required? :	Yes
Sub-Section Number :	1
Sub-Section Id :	864351189

Question Shuffling Allowed :

Yes

Question Number : 31 Question Id : 8643512821 Question Type : MCQ Option Shuffling : Yes Is Question Mandatory : No

Correct Marks : 4 Wrong Marks : 1

A central atom in a molecule has two lone pairs of electrons and forms three single bonds. The shape of this molecule is :

Options :

8643518461. planar triangular

8643518462. T-shaped

8643518463. see-saw

8643518464. trigonal pyramidal

Question Number : 31 Question Id : 8643512821 Question Type : MCQ Option Shuffling : Yes Is Question Mandatory : No

Correct Marks : 4 Wrong Marks : 1

ଏକ ଅଣୁରେ ଥିବା କେନ୍ଦ୍ରୀୟ ପରମାଣୁରେ ଦୁଇ ଲୋନ୍ ପେୟାର୍ ଇଲେକ୍ଟ୍ରନ୍ ଅଛନ୍ତି ଏବଂ ତିନି ଏକାକୀ ବନ୍ଧ ଗଠନ କରନ୍ତି । ଉକ୍ତ ଅଣୁର ଆକୃତି ହେଉଛି :

Options :

8643518461. ପ୍ଲାନାର ତ୍ରିଭୁଜାକାର

8643518462. T-ଆକୃତି

8643518463. ସି-ସା

8643518464. ତ୍ରିଭୁଜାକାର ପିରାମିଡାଲ

Question Number : 32 Question Id : 8643512822 Question Type : MCQ Option Shuffling : Yes Is Question Mandatory : No

Correct Marks : 4 Wrong Marks : 1

A colloidal system consisting of a gas dispersed in a solid is called a/an :

Options :

8643518465. aerosol

8643518466. solid sol

8643518467. foam

8643518468. gel

Question Number : 32 Question Id : 8643512822 Question Type : MCQ Option Shuffling : Yes Is Question Mandatory : No

Correct Marks : 4 Wrong Marks : 1

ଏକ ଗ୍ୟାସ୍ ଅନ୍ୟ ଏକ କଠିନ ବସ୍ତୁରେ ପରିକ୍ଷେପଣ ହେବା ଦ୍ୱାରା ଗଠିତ କଲିଲ ଅବସ୍ଥାକୁ କୁହାଯାଏ :

Options :

8643518465. ଏରୋସଲ୍

8643518466. ସଲିଡ୍ ସଲ୍

8643518467. ଫୋମ୍

8643518468. ଜେଲ୍

Question Number : 33 Question Id : 8643512823 Question Type : MCQ Option Shuffling : Yes Is Question Mandatory : No

Correct Marks : 4 Wrong Marks : 1

The absolute value of the electron gain enthalpy of halogens satisfies :

Options :

8643518469. $F > Cl > Br > I$ 8643518470. $Cl > F > Br > I$ 8643518471. $Cl > Br > F > I$ 8643518472. $I > Br > Cl > F$

Question Number : 33 Question Id : 8643512823 Question Type : MCQ Option Shuffling : Yes Is Question Mandatory : No

Correct Marks : 4 Wrong Marks : 1

ହାଇଡ୍ରୋଜେନସ୍ ଗୁଡ଼ିକର ଇଲେକ୍ଟ୍ରନ୍ ପ୍ରାପ୍ତ ପୂର୍ଣ୍ଣତାପର ପରମ ମୂଲ୍ୟ ସନ୍ତୁଷ୍ଟ କରୁଥିବା ବିକଳ୍ପଟି :

Options :

8643518469. $F > Cl > Br > I$ 8643518470. $Cl > F > Br > I$ 8643518471. $Cl > Br > F > I$ 8643518472. $I > Br > Cl > F$

Question Number : 34 Question Id : 8643512824 Question Type : MCQ Option Shuffling : Yes Is Question Mandatory : No

Correct Marks : 4 Wrong Marks : 1

The point of intersection and sudden increase in the slope, in the diagram given below, respectively, indicates :

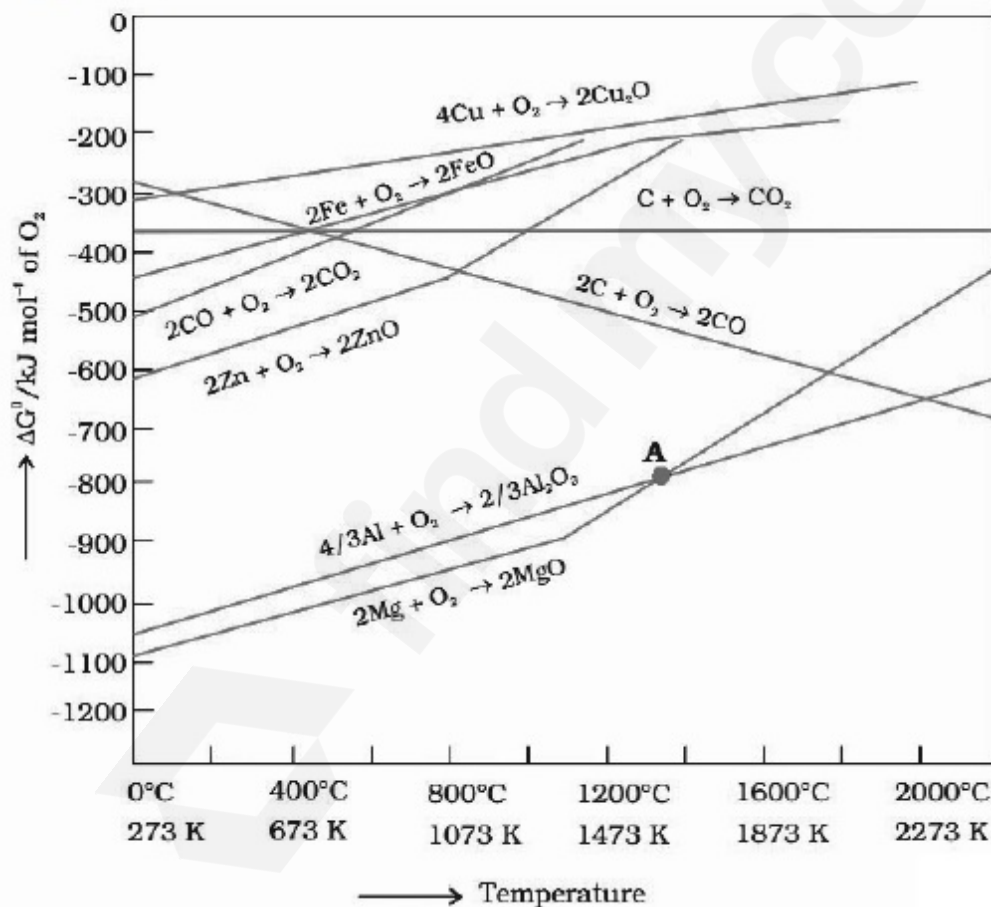

Options :

8643518473. $\Delta G < 0$ and decomposition of the metal oxide8643518474. $\Delta G > 0$ and decomposition of the metal oxide

8643518475. $\Delta G = 0$ and melting or boiling point of the metal oxide

8643518476. $\Delta G = 0$ and reduction of the metal oxide

Question Number : 34 Question Id : 8643512824 Question Type : MCQ Option Shuffling : Yes Is Question Mandatory : No

Correct Marks : 4 Wrong Marks : 1

ନିମ୍ନୋକ୍ତରେ ଛେଦବିନ୍ଦୁ ଏବଂ ସ୍ଳୋପର ହଠାତ୍ ବଦଳି ଯଥାକ୍ରମେ ସୂଚିତ କରୁଛି ?

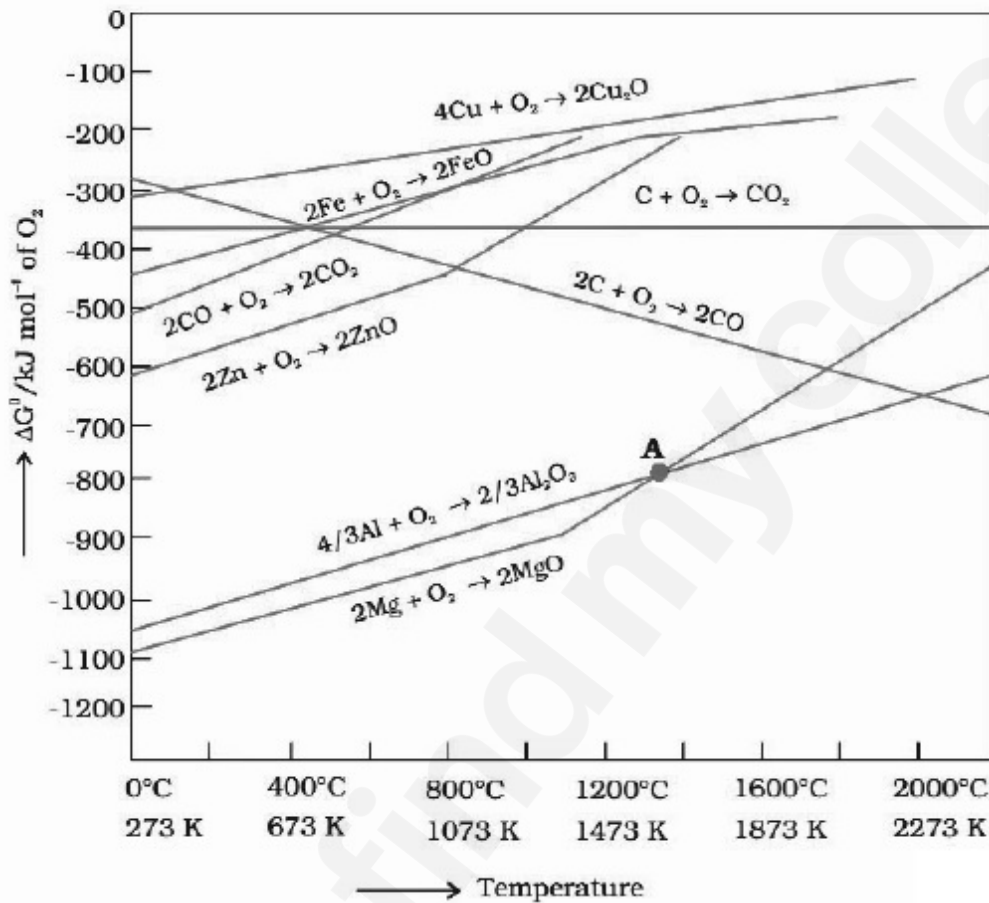

Options :

8643518473. $\Delta G < 0$ ଏବଂ ଧାତୁ ଅକ୍ସାଇଡର ବିଘଟନ

8643518474. $\Delta G > 0$ ଏବଂ ଧାତୁ ଅକ୍ସାଇଡର ବିଘଟନ

8643518475. $\Delta G = 0$ ଏବଂ ଧାତୁ ଅକ୍ସାଇଡର ଗଳନାଙ୍କ କିମ୍ବା ସ୍ମୃତନାଙ୍କ

8643518476. $\Delta G = 0$ ଏବଂ ଧାତୁ ଅକ୍ସାଇଡର ବିଜାରଣ

Question Number : 35 Question Id : 8643512825 Question Type : MCQ Option Shuffling : Yes Is

Question Mandatory : No

Correct Marks : 4 Wrong Marks : 1

The INCORRECT statement(s) about heavy water is (are)

- (A) used as a moderator in nuclear reactor
- (B) obtained as a by-product in fertilizer industry
- (C) used for the study of reaction mechanism
- (D) has a higher dielectric constant than water

Choose the correct answer from the options given below :

Options :

8643518477. (C) only

8643518478. (B) only

8643518479. (D) only

8643518480. (B) and (D) only

Question Number : 35 Question Id : 8643512825 Question Type : MCQ Option Shuffling : Yes Is

Question Mandatory : No

Correct Marks : 4 Wrong Marks : 1

ଭାରୀଜଳ ବିଷୟରେ ଭୁଲ ଉକ୍ତି(ଗୁଡ଼ିକ) ହେଉଛି :

- (A) ନ୍ୟୁକ୍ଲିୟର ରିଏକ୍ଟରରେ ମନ୍ଦକ ଭାବେ ବ୍ୟବହୃତ ହୁଏ
- (B) ସାରଣୀକ୍ଷରେ ଉପଜାତ ଦ୍ରବ୍ୟ ରୂପେ ମିଳିଥାଏ
- (C) ପ୍ରତିକ୍ରିୟାର ମୋକାନ୍ତିଜିମ୍ ଅଧ୍ୟୟନ କରିବା ପାଇଁ ବ୍ୟବହୃତ ହୁଏ
- (D) ଭାରି ଜଳର ପରାବୈଦ୍ୟୁତାଙ୍କ ଜଳର ପରାବୈଦ୍ୟୁତାଙ୍କ ଠାରୁ ଅଧିକ ।

ନିମ୍ନଲିଖିତ ବିକଳ୍ପ ମଧ୍ୟରୁ ସଠିକ୍ ଉତ୍ତରଟି ବାଛି :

Options :

8643518477. (C) କେବଳ

8643518478. (B) କେବଳ

8643518479. (D) କେବଳ

8643518480. (B) ଏବଂ (D) କେବଳ

Question Number : 36 Question Id : 8643512826 Question Type : MCQ Option Shuffling : Yes Is

Question Mandatory : No

Correct Marks : 4 Wrong Marks : 1

The correct order of conductivity of ions in water is :

Options :

8643518481. $\text{Cs}^+ > \text{Rb}^+ > \text{K}^+ > \text{Na}^+$

8643518482. $\text{Na}^+ > \text{K}^+ > \text{Rb}^+ > \text{Cs}^+$

8643518483. $\text{K}^+ > \text{Na}^+ > \text{Cs}^+ > \text{Rb}^+$

8643518484. $\text{Rb}^+ > \text{Na}^+ > \text{K}^+ > \text{Li}^+$

Question Number : 36 Question Id : 8643512826 Question Type : MCQ Option Shuffling : Yes Is

Question Mandatory : No

Correct Marks : 4 Wrong Marks : 1

ଜଳରେ ପରିବାହିତାର ସଠିକ୍ କ୍ରମଟି ହେଉଛି :

Options :

8643518481. $\text{Cs}^+ > \text{Rb}^+ > \text{K}^+ > \text{Na}^+$

8643518482. $\text{Na}^+ > \text{K}^+ > \text{Rb}^+ > \text{Cs}^+$

8643518483. $\text{K}^+ > \text{Na}^+ > \text{Cs}^+ > \text{Rb}^+$

8643518484. $\text{Rb}^+ > \text{Na}^+ > \text{K}^+ > \text{Li}^+$

Question Number : 37 Question Id : 8643512827 Question Type : MCQ Option Shuffling : Yes Is

Question Mandatory : No

Correct Marks : 4 Wrong Marks : 1

Which of the following compound CANNOT act as a Lewis base ?

Options :

8643518485. ClF_3

8643518486. PCl_5

8643518487. NF_3

8643518488. SF_4

Question Number : 37 Question Id : 8643512827 Question Type : MCQ Option Shuffling : Yes Is

Question Mandatory : No

Correct Marks : 4 Wrong Marks : 1

ନିମ୍ନଲିଖିତ କେଉଁ ଯୌଗିକଟି ଲୁଇସ୍ କ୍ଷାର ପରି କାର୍ଯ୍ୟ କରେ ନାହିଁ ?

Options :

8643518485. ClF_3 8643518486. PCl_5 8643518487. NF_3 8643518488. SF_4

Question Number : 38 Question Id : 8643512828 Question Type : MCQ Option Shuffling : Yes Is

Question Mandatory : No

Correct Marks : 4 Wrong Marks : 1

What is the spin-only magnetic moment value (BM) of a divalent metal ion with atomic number 25, in it's aqueous solution ?

Options :

8643518489. 5.0

8643518490. 5.26

8643518491. 5.92

8643518492. zero

Question Number : 38 Question Id : 8643512828 Question Type : MCQ Option Shuffling : Yes Is

Question Mandatory : No

Correct Marks : 4 Wrong Marks : 1

ପାରମାଣବିକ ସଂଖ୍ୟା 25 ଥିବା ଦ୍ୱିସଂଯୋଜକ ଧାତବ ଆୟନର ସ୍ପିନ୍ କେବଳ ବୁଲ୍‌କାନ୍ଦ ଆୟତ୍ତର ମୂଲ୍ୟ ଏହାର ଜଳୀୟ ଦ୍ରବଣରେ କେତେ ?

Options :

8643518489. 5.0

8643518490. 5.26

8643518491. 5.92

8643518492. ଶୂନ୍ୟ

Question Number : 39 Question Id : 8643512829 Question Type : MCQ Option Shuffling : Yes Is Question Mandatory : No

Correct Marks : 4 Wrong Marks : 1

Given below are two statements :

Statement I : Potassium permanganate on heating at 573 K forms potassium manganate.

Statement II : Both potassium permanganate and potassium manganate are tetrahedral and paramagnetic in nature.

In the light of the above statements, choose the most appropriate answer from the options given below :

Options :

8643518493. Both statement I and statement II are false

8643518494. Both statement I and statement II are true

8643518495. Statement I is true but statement II is false

8643518496. Statement I is false but statement II is true

Question Number : 39 Question Id : 8643512829 Question Type : MCQ Option Shuffling : Yes Is Question Mandatory : No

Correct Marks : 4 Wrong Marks : 1

ନିମ୍ନରେ ଦୁଇଟି ଉକ୍ତି ଦିଆଯାଇଛି :

ଉକ୍ତି I : 573 K ଉତ୍ତାପରେ ପଟାସିୟମ୍ ପରମାଙ୍ଗାନେଟକୁ ଗରମ କଲେ ପଟାସିୟମ୍ ମାଙ୍ଗାନେଟ୍ ଗଠନ ହୁଏ ।

ଉକ୍ତି II : ପଟାସିୟମ୍ ପରମାଙ୍ଗାନେଟ୍ ଏବଂ ପଟାସିୟମ୍ ମାଙ୍ଗାନେଟ୍ ଉଭୟ ଟେଟ୍ରାହେଡ୍ରାଲ୍ ଏବଂ ଅନୁଚୁମ୍ବକୀୟ ପ୍ରକୃତିର

ଉପରୋକ୍ତ ଉକ୍ତି ଅନୁସାରେ, ନିମ୍ନଲିଖିତ ବିକଳ୍ପ ମଧ୍ୟରୁ ସର୍ବାଧିକ ଉପଯୁକ୍ତ ଉତ୍ତରଟି ବାଛି :

Options :

8643518493. ଉକ୍ତି I ଏବଂ ଉକ୍ତି II ଉଭୟ ମିଥ୍ୟା

8643518494. ଉକ୍ତି I ଏବଂ ଉକ୍ତି II ଉଭୟ ସତ୍ୟ

8643518495. ଉକ୍ତି I ସତ୍ୟ କିନ୍ତୁ ଉକ୍ତି II ମିଥ୍ୟା

8643518496. ଉକ୍ତି I ମିଥ୍ୟା କିନ୍ତୁ ଉକ୍ତି II ସତ୍ୟ

Question Number : 40 Question Id : 8643512830 Question Type : MCQ Option Shuffling : Yes Is Question Mandatory : No

Correct Marks : 4 Wrong Marks : 1

Reducing smog is a mixture of :

Options :

8643518497. Smoke, fog and O_3

8643518498. Smoke, fog and SO_2

8643518499. Smoke, fog and N_2O_3

8643518500. Smoke, fog and $CH_2=CH-CHO$

Question Number : 40 Question Id : 8643512830 Question Type : MCQ Option Shuffling : Yes Is Question Mandatory : No

Correct Marks : 4 Wrong Marks : 1

ବିଜାରଣ ସ୍ମୋଗ୍ ଏକ ମିଶ୍ରଣ ଅଟେ :

Options :

8643518497. ଧୂଆଁ, କୁହୁଡ଼ି ଏବଂ O_3

8643518498. ଧୂଆଁ, କୁହୁଡ଼ି ଏବଂ SO_2

8643518499. ଧୂଆଁ, କୁହୁଡ଼ି ଏବଂ N_2O_3

8643518500. ଧୂଆଁ, କୁହୁଡ଼ି ଏବଂ $CH_2=CH-CHO$

Question Number : 41 Question Id : 8643512831 Question Type : MCQ Option Shuffling : Yes Is Question Mandatory : No

Correct Marks : 4 Wrong Marks : 1

Given below are two statements :

Statement I : Retardation factor (R_f) can be measured in meter/centimeter.

Statement II : R_f value of a compound remains constant in all solvents.

Choose the most appropriate answer from the options given below :

Options :

8643518501. Both statement I and statement II are true

8643518502. Both statement I and statement II are false

8643518503. Statement I is true but statement II is false

8643518504. Statement I is false but statement II is true

Question Number : 41 Question Id : 8643512831 Question Type : MCQ Option Shuffling : Yes Is Question Mandatory : No

Correct Marks : 4 Wrong Marks : 1

ନିମ୍ନରେ ଦୁଇଟି ଉକ୍ତି ଦିଆଯାଇଛି :

ଉକ୍ତି I : ମନ୍ଦନକାରକ ମିଶ୍ରଣ/ସେଣ୍ଟିମିଟରରେ ମପାଯାଏ । (R_f)

ଉକ୍ତି II : ଏକ ଯୌଗିକର R_f ମୂଲ୍ୟ ସବୁ ଦ୍ରାବକରେ ସ୍ଥିର ରହିଥାଏ ।

ନିମ୍ନଲିଖିତ ବିକଳ୍ପ ମଧ୍ୟରୁ ସର୍ବାଧିକ ଉପଯୁକ୍ତ ଉତ୍ତରଟି ବାଛି :

Options :

8643518501. ଉକ୍ତି I ଏବଂ ଉକ୍ତି II ଉଭୟ ସତ୍ୟ

8643518502. ଉକ୍ତି I ଏବଂ ଉକ୍ତି II ଉଭୟ ମିଥ୍ୟା

8643518503. ଉକ୍ତି I ସତ୍ୟ କିନ୍ତୁ ଉକ୍ତି II ମିଥ୍ୟା

8643518504. ଉକ୍ତି I ମିଥ୍ୟା କିନ୍ତୁ ଉକ୍ତି II ସତ୍ୟ

Question Number : 42 Question Id : 8643512832 Question Type : MCQ Option Shuffling : Yes Is Question Mandatory : No

Correct Marks : 4 Wrong Marks : 1

Which of the following is an aromatic compound ?

Options :

8643518505.

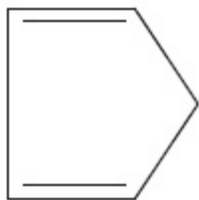

8643518506.

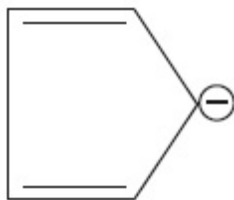

8643518507.



8643518508.

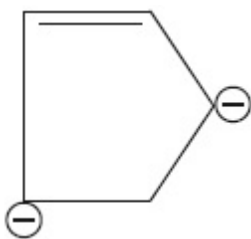

Question Number : 42 Question Id : 8643512832 Question Type : MCQ Option Shuffling : Yes Is Question Mandatory : No

Correct Marks : 4 Wrong Marks : 1

ନିମ୍ନ ମଧ୍ୟରୁ କେଉଁଟି ଆରୋମାଟିକ୍ ଯୌଗିକ ଅଟେ ?

Options :

8643518505.



8643518506.

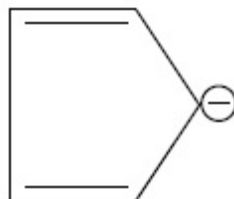

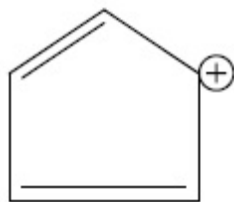

8643518507.

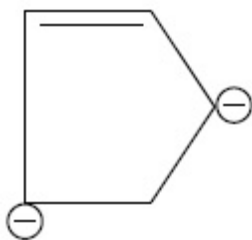

8643518508.

Question Number : 43 Question Id : 8643512833 Question Type : MCQ Option Shuffling : Yes Is Question Mandatory : No

Correct Marks : 4 Wrong Marks : 1

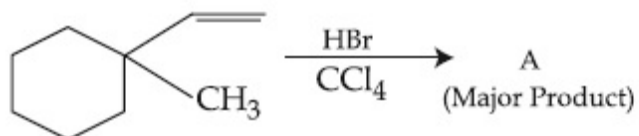

Product "A" in the above chemical reaction is :

Options :

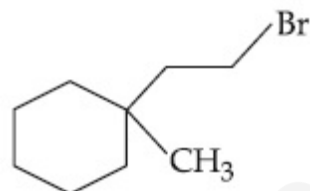

8643518509.

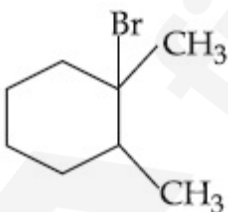

8643518510.

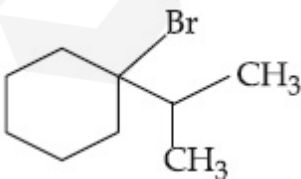

8643518511.

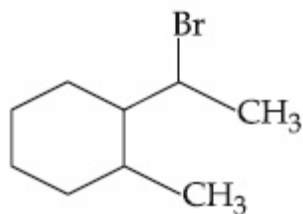

8643518512.

Question Number : 43 Question Id : 8643512833 Question Type : MCQ Option Shuffling : Yes Is Question Mandatory : No

Correct Marks : 4 Wrong Marks : 1

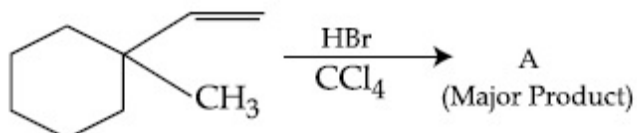

ଉପରୋକ୍ତ ରାସାୟନିକ ପ୍ରତିକ୍ରିୟାରେ ଉତ୍ପାଦ "A" ହେଉଛି :

Options :

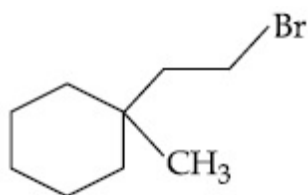

8643518509.

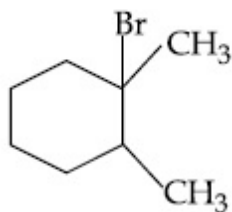

8643518510.

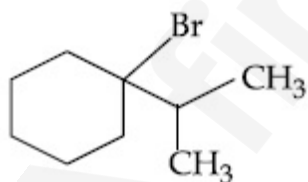

8643518511.

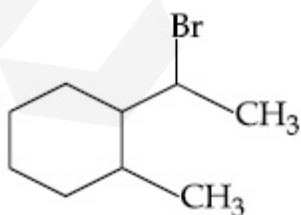

8643518512.

Question Number : 44 Question Id : 8643512834 Question Type : MCQ Option Shuffling : Yes Is Question Mandatory : No

Correct Marks : 4 Wrong Marks : 1

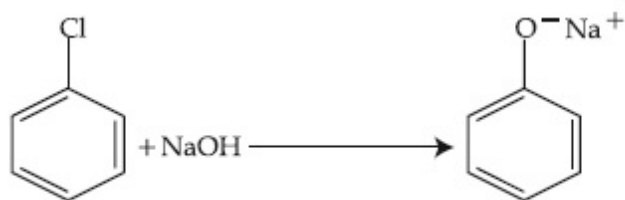

The above reaction requires which of the following reaction conditions ?

Options :

8643518513. 623 K, Cu, 300 atm

8643518514. 573 K, Cu, 300 atm

8643518515. 623 K, 300 atm

8643518516. 573 K, 300 atm

Question Number : 44 Question Id : 8643512834 Question Type : MCQ Option Shuffling : Yes Is Question Mandatory : No

Correct Marks : 4 Wrong Marks : 1

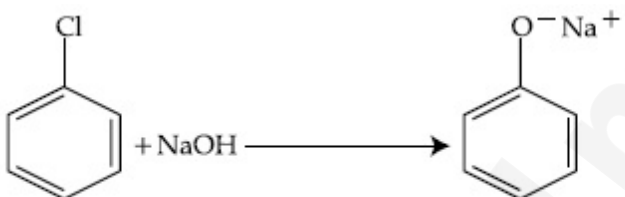

ଉପରୋକ୍ତ ପ୍ରତିକ୍ରିୟାରେ ନିମ୍ନଲିଖିତ କେଉଁ ପ୍ରତିକ୍ରିୟା ସର୍ତ୍ତ ଆବଶ୍ୟକ ହୋଇଥାଏ ?

Options :

8643518513. 623 K, Cu, 300 atm

8643518514. 573 K, Cu, 300 atm

8643518515. 623 K, 300 atm

8643518516. 573 K, 300 atm

Question Number : 45 Question Id : 8643512835 Question Type : MCQ Option Shuffling : Yes Is Question Mandatory : No

Correct Marks : 4 Wrong Marks : 1

Mesityl oxide is a common name of :

Options :

8643518517. 4-Methyl pent-3-en-2-one
8643518518. 2,4-Dimethyl pentan-3-one
8643518519. 2-Methyl cyclohexanone
8643518520. 3-Methyl cyclohexane carbaldehyde

Question Number : 45 Question Id : 8643512835 Question Type : MCQ Option Shuffling : Yes Is Question Mandatory : No

Correct Marks : 4 Wrong Marks : 1

ନିମ୍ନଲିଖିତ ମଧ୍ୟରୁ କାହାର ସାଧାରଣ ନାମ ମେସିଟିଲ୍ ଅକ୍ସାଲଡ୍ ?

Options :

8643518517. 4-ମିଥାଇଲ ପେଣ୍ଟ-3-ଇନ୍-2-ଓନ୍
8643518518. 2,4-ଡାଇମିଥାଇଲ ପେଣ୍ଟାନ୍-3-ଓନ୍
8643518519. 2-ମିଥାଇଲ ସାଇକ୍ଲୋହେକ୍ସାନୋନ୍
8643518520. 3-ମିଥାଇଲ ସାଇକ୍ଲୋହେକ୍ସେନ୍ କାର୍ବଲଡିହାଇଡ

Question Number : 46 Question Id : 8643512836 Question Type : MCQ Option Shuffling : Yes Is Question Mandatory : No

Correct Marks : 4 Wrong Marks : 1

Hoffmann bromomide degradation of benzamide gives product A, which upon heating with CHCl_3 and NaOH gives product B.

The structures of A and B are :

Options :

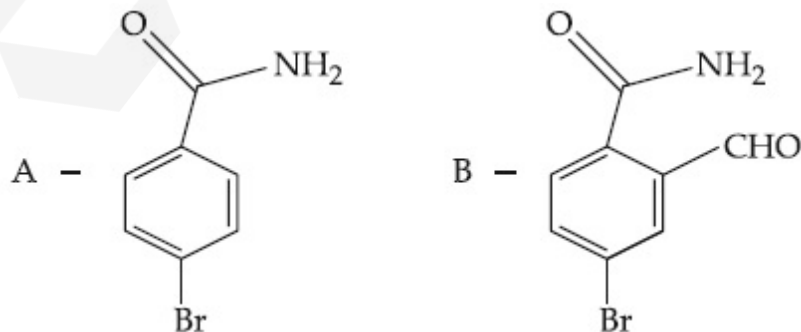

8643518521.

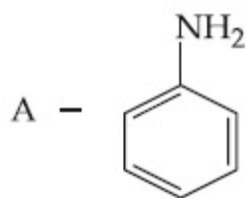

8643518522.

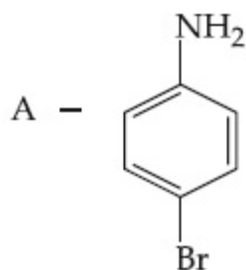
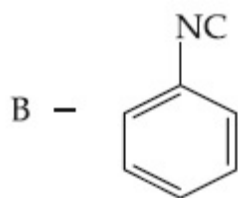

8643518523.

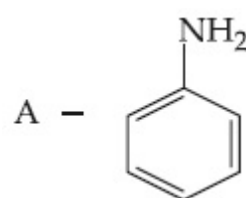
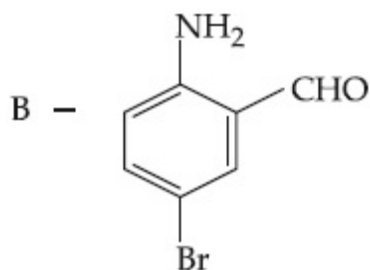

8643518524.

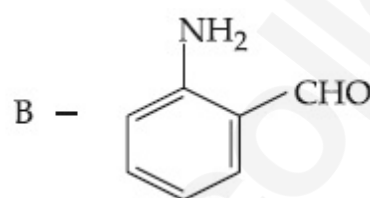

Question Number : 46 Question Id : 8643512836 Question Type : MCQ Option Shuffling : Yes Is Question Mandatory : No

Correct Marks : 4 Wrong Marks : 1

ବେଞ୍ଜାମାଇଡ୍‌ର ହଫ୍‌ମ୍ୟାନ୍ ଟ୍ରୋମାମାଇଡ୍ ଅବକ୍ରମଣ ଦ୍ୱାରା ଉତ୍ପାଦ A ଦେଖିବା ଯାହାକୁ CHCl_3 ଏବଂ NaOH ସହ ଗରମ କଲେ ଉତ୍ପାଦ B ଦିଏ । A ଏବଂ B ର ସଂରଚନା ଯଥାକ୍ରମେ ହେଉଛି :

Options :

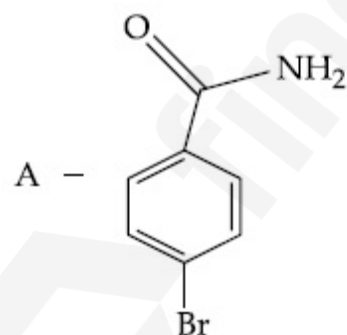

8643518521.

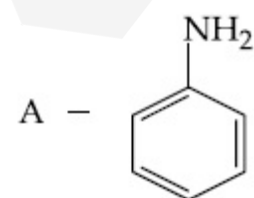
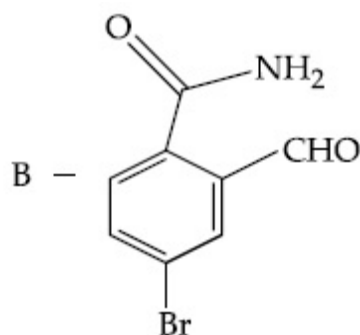

8643518522.

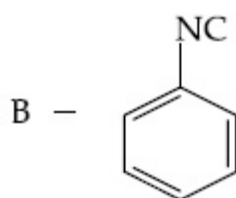

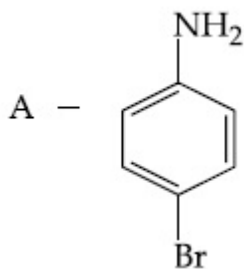

8643518523.

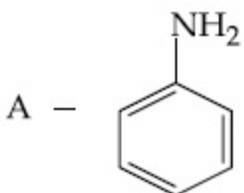
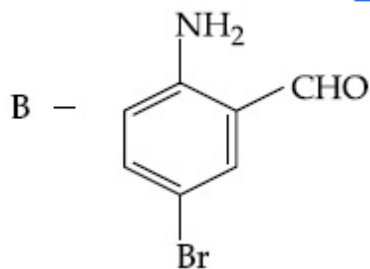

8643518524.

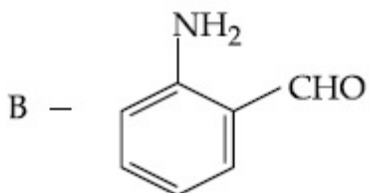

Question Number : 47 Question Id : 8643512837 Question Type : MCQ Option Shuffling : Yes Is Question Mandatory : No

Correct Marks : 4 Wrong Marks : 1

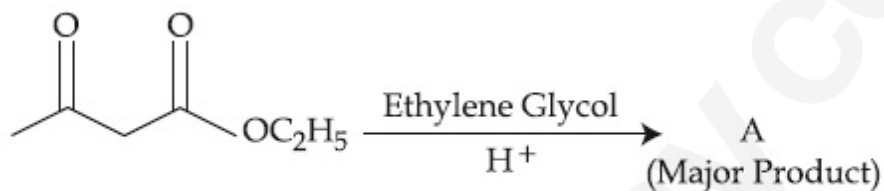

The product "A" in the above reaction is :

Options :

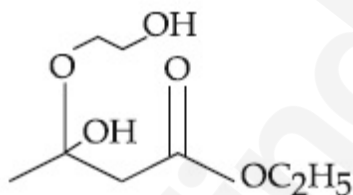

8643518525.

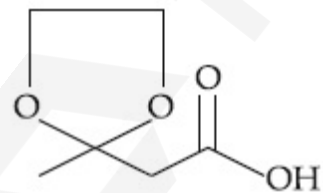

8643518526.

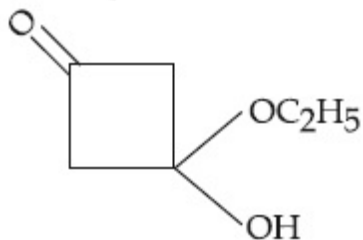

8643518527.

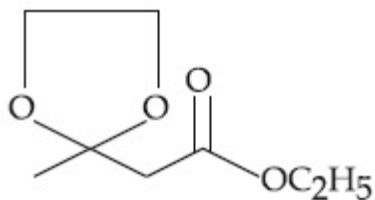

8643518528.

Question Number : 47 Question Id : 8643512837 Question Type : MCQ Option Shuffling : Yes Is Question Mandatory : No

Correct Marks : 4 Wrong Marks : 1

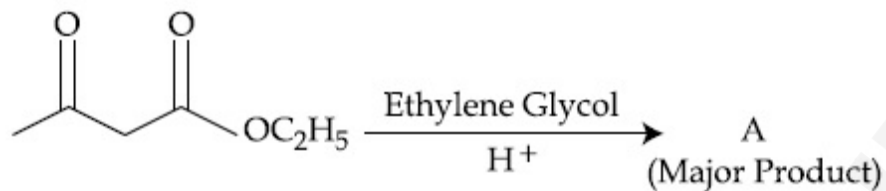

ଉପରୋକ୍ତ ପ୍ରତିକ୍ରିୟାରେ ଉତ୍ପାଦ "A" ହେଉଛି :

Options :

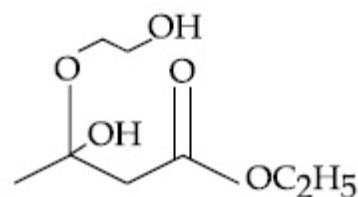

8643518525.

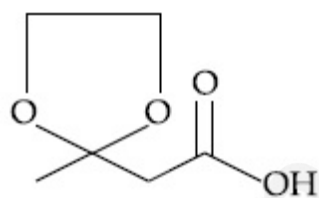

8643518526.

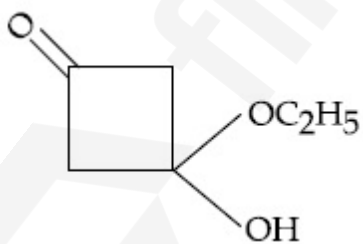

8643518527.

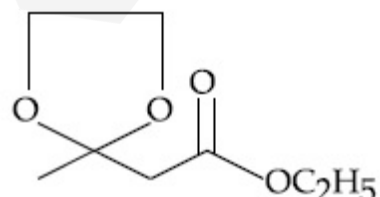

8643518528.

Question Number : 48 Question Id : 8643512838 Question Type : MCQ Option Shuffling : Yes Is

Question Mandatory : No

Correct Marks : 4 Wrong Marks : 1

Which of the following reaction is an example of ammonolysis ?

Options :

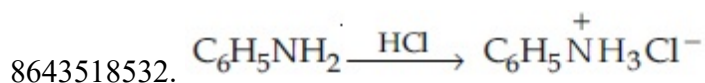
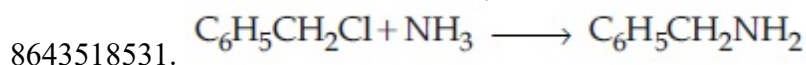
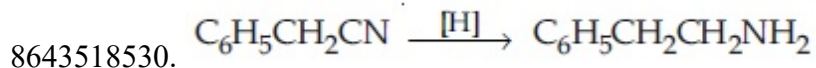
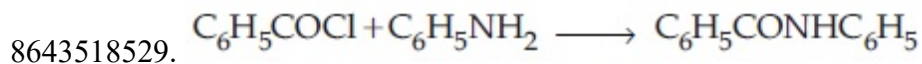

Question Number : 48 Question Id : 8643512838 Question Type : MCQ Option Shuffling : Yes Is

Question Mandatory : No

Correct Marks : 4 Wrong Marks : 1

ନିମ୍ନଲିଖିତ ପ୍ରତିକ୍ରିୟା ମଧ୍ୟରୁ କେଉଁଟି ଆମୋନୋଲିସିସ୍‌ର ଏକ ଉଦାହରଣ ?

Options :

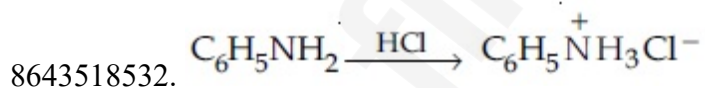
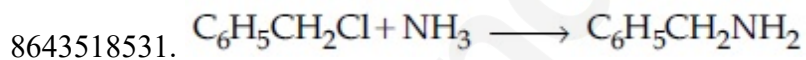
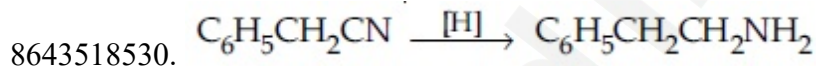
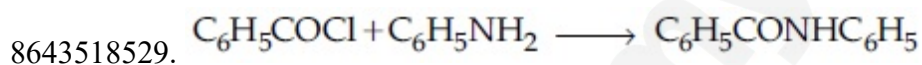

Question Number : 49 Question Id : 8643512839 Question Type : MCQ Option Shuffling : Yes Is

Question Mandatory : No

Correct Marks : 4 Wrong Marks : 1

With respect to drug-enzyme interaction, identify the wrong statement.

Options :

8643518533. Competitive inhibitor binds to the enzyme's active site

8643518534. Allosteric inhibitor changes the enzyme's active site

8643518535. Allosteric inhibitor competes with the enzyme's active site

8643518536. Non-Competitive inhibitor binds to the allosteric site

Question Number : 49 Question Id : 8643512839 Question Type : MCQ Option Shuffling : Yes Is

Question Mandatory : No

Correct Marks : 4 Wrong Marks : 1

ଭୂତ-ଏନ୍‌ଜାଇମ୍ ପାରାସ୍ତରିକ ପ୍ରତିକ୍ରିୟା ସମ୍ବନ୍ଧରେ, ଭୁଲ୍ କଥନଟିକୁ ଚିହ୍ନାଅ :

Options :

8643518533. ପ୍ରତିଯୋଗୀ ନିରୋଧକ ଏନ୍‌ଜାଇମ୍‌ର ସକ୍ରିୟ ପାର୍ଶ୍ଵକୁ ବାନ୍ଧି ରଖେ ।

8643518534. ଏଲୋଷ୍ଟେରିକ୍ ନିରୋଧକ ଏନ୍‌ଜାଇମ୍‌ର ସକ୍ରିୟ ପାର୍ଶ୍ଵକୁ ବଦଳାଇ ଦିଏ ।

8643518535. ଏଲୋଷ୍ଟେରିକ୍ ନିରୋଧକ ଏନ୍‌ଜାଇମ୍‌ର ସକ୍ରିୟ ପାର୍ଶ୍ଵ ସହ ପ୍ରତିଯୋଗିତା କରେ ।

8643518536. ଅଣ-ପ୍ରତିଯୋଗୀ ନିରୋଧକ ଏଲୋଷ୍ଟେରିକ୍ ପାର୍ଶ୍ଵକୁ ବାନ୍ଧି ରଖେ ।

Question Number : 50 Question Id : 8643512840 Question Type : MCQ Option Shuffling : Yes Is

Question Mandatory : No

Correct Marks : 4 Wrong Marks : 1

Which of the following is correct structure of tyrosine ?

Options :

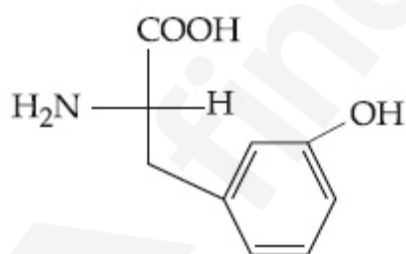

8643518537.

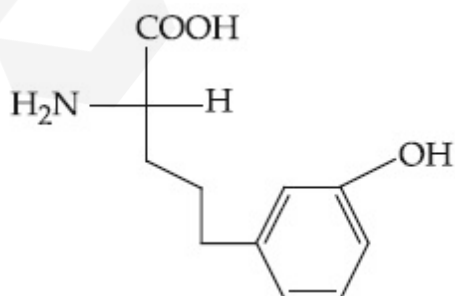

8643518538.

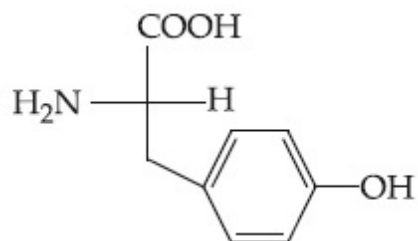

8643518539.

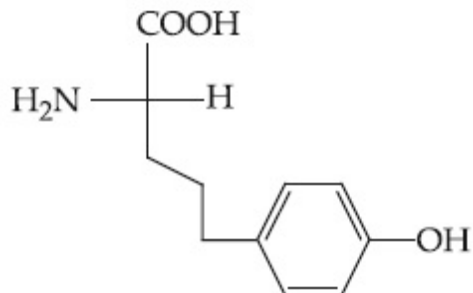

8643518540.

Question Number : 50 Question Id : 8643512840 Question Type : MCQ Option Shuffling : Yes Is Question Mandatory : No

Correct Marks : 4 Wrong Marks : 1

ନିମ୍ନଲିଖିତ ମଧ୍ୟରୁ କେଉଁଟି ଟାଇରୋସିନ୍‌ର ସଠିକ୍ ସଂରଚନା ଅଟେ ?

Options :

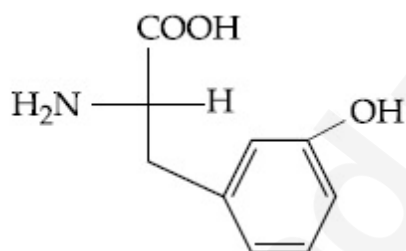

8643518537.

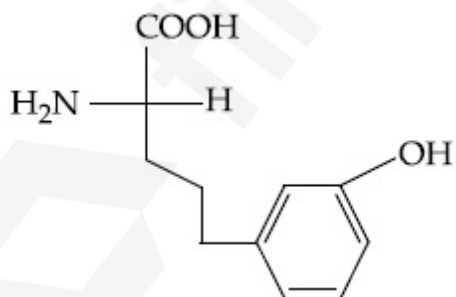

8643518538.

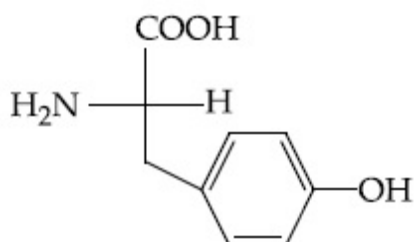

8643518539.

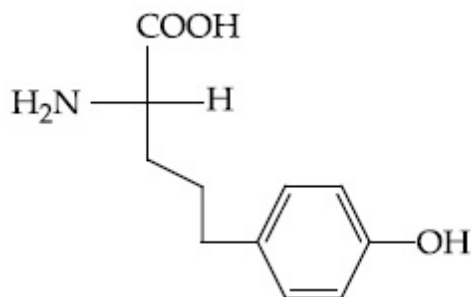

8643518540.

Chemistry Section B

Section Id :	864351190
Section Number :	4
Section type :	Online
Mandatory or Optional :	Mandatory
Number of Questions :	10
Number of Questions to be attempted :	5
Section Marks :	20
Mark As Answered Required? :	Yes
Sub-Section Number :	1
Sub-Section Id :	864351190
Question Shuffling Allowed :	Yes

Question Number : 51 Question Id : 8643512841 Question Type : SA

Correct Marks : 4 Wrong Marks : 0

The mole fraction of a solute in a 100 molal aqueous solution is _____ $\times 10^{-2}$.
(Round off to the Nearest Integer).

[Given : Atomic masses : H : 1.0 u, O : 16.0 u]

Response Type : Numeric

Evaluation Required For SA : Yes

Show Word Count : Yes

Answers Type : Equal

Text Areas : PlainText

Possible Answers :

100

Question Number : 51 Question Id : 8643512841 Question Type : SA

Correct Marks : 4 Wrong Marks : 0

100 ମୋଲାଲ ଜଳୀୟ ଦ୍ରବଣରେ ଦ୍ରାବ୍ୟର ମୋଲ ଫ୍ରାକ୍ସନ୍ _____ $\times 10^{-2}$ ଅଟେ ।

(ନିକଟତମ ପୂର୍ଣ୍ଣସଂଖ୍ୟାରେ ଉତ୍ତର)

[ଦତ୍ତ : ପରମାଣବିକ ବସ୍ତୁତ୍ତ୍ୱ : H : 1.0 u, O : 16.0 u]

Response Type : Numeric

Evaluation Required For SA : Yes

Show Word Count : Yes

Answers Type : Equal

Text Areas : PlainText

Possible Answers :

100

Question Number : 52 Question Id : 8643512842 Question Type : SA

Correct Marks : 4 Wrong Marks : 0

The pressure exerted by a non-reactive gaseous mixture of 6.4 g of methane and 8.8 g of carbon dioxide in a 10 L vessel at 27°C is _____ kPa.

(Round off to the Nearest Integer).

[Assume gases are ideal, $R = 8.314 \text{ J mol}^{-1} \text{ K}^{-1}$

Atomic masses : C : 12.0 u, H : 1.0 u, O : 16.0 u]

Response Type : Numeric

Evaluation Required For SA : Yes

Show Word Count : Yes

Answers Type : Equal

Text Areas : PlainText

Possible Answers :

100

Question Number : 52 Question Id : 8643512842 Question Type : SA

Correct Marks : 4 Wrong Marks : 0

10 L ପାତ୍ରରେ 27°C ତାପମାତ୍ରାରେ 6.4 g ମିଥେନ୍ ଏବଂ 8.8 g କାର୍ବନ୍ ଡାଇଅକ୍ସାଇଡ୍ ଅପ୍ରତିକ୍ରିୟାଶୀଳ ମିଶ୍ରଣ ଦ୍ୱାରା ଉତ୍ପନ୍ନ ଚାପ _____ kPa ଅଟେ ।

(ନିକଟତମ ପୂର୍ଣ୍ଣସଂଖ୍ୟାରେ ପରିଣତ କର)

[ଗ୍ୟାସ୍ ଗୁଡ଼ିକୁ ଆଦର୍ଶ ଗ୍ୟାସ୍ ମାନ୍ୟତା ଦିଅ । $R = 8.314 \text{ J mol}^{-1} \text{ K}^{-1}$ ପାରମାଣବିକ ବସ୍ତୁତ୍ୱ C : 12.0 u, H : 1.0 u, O : 16.0 u]

Response Type : Numeric

Evaluation Required For SA : Yes

Show Word Count : Yes

Answers Type : Equal

Text Areas : PlainText

Possible Answers :

100

Question Number : 53 Question Id : 8643512843 Question Type : SA

Correct Marks : 4 Wrong Marks : 0

A certain orbital has $n=4$ and $m_L = -3$. The number of radial nodes in this orbital is _____. (Round off to the Nearest Integer).

Response Type : Numeric

Evaluation Required For SA : Yes

Show Word Count : Yes

Answers Type : Equal

Text Areas : PlainText

Possible Answers :

100

Question Number : 53 **Question Id :** 8643512843 **Question Type :** SA

Correct Marks : 4 **Wrong Marks :** 0

ଏକ ନିର୍ଦ୍ଦିଷ୍ଟ ଅରବିଟାଲରେ $n=4$ ଏବଂ $m_L = -3$ ଅଛି । ଉକ୍ତ ଅରବିଟାଲର ରେଡିଆଲ୍ ନୋଡ୍ ସଂଖ୍ୟା _____ ।
(ନିକଟତମ ପୂର୍ଣ୍ଣସଂଖ୍ୟାରେ ପରିଣତ କର)

Response Type : Numeric

Evaluation Required For SA : Yes

Show Word Count : Yes

Answers Type : Equal

Text Areas : PlainText

Possible Answers :

100

Question Number : 54 **Question Id :** 8643512844 **Question Type :** SA

Correct Marks : 4 **Wrong Marks :** 0

The standard enthalpies of formation of Al_2O_3 and CaO are $-1675 \text{ kJ mol}^{-1}$ and -635 kJ mol^{-1} respectively.

For the reaction

$3\text{CaO} + 2\text{Al} \rightarrow 3\text{Ca} + \text{Al}_2\text{O}_3$ the standard reaction enthalpy $\Delta_r H^0 =$ _____ kJ.

(Round off to the Nearest Integer).

Response Type : Numeric

Evaluation Required For SA : Yes

Show Word Count : Yes

Answers Type : Equal

Text Areas : PlainText

Possible Answers :

100

Question Number : 54 **Question Id :** 8643512844 **Question Type :** SA

Correct Marks : 4 **Wrong Marks :** 0

Al_2O_3 ଏବଂ CaO ଗଠନର ମାନକ ପୂର୍ଣ୍ଣତାପ ଯଥାକ୍ରମେ $-1675 \text{ kJ mol}^{-1}$ ଏବଂ -635 kJ mol^{-1} ।

ପ୍ରତିକ୍ରିୟା $3\text{CaO} + 2\text{Al} \rightarrow 3\text{Ca} + \text{Al}_2\text{O}_3$ ର ମାନକ ପ୍ରତିକ୍ରିୟା ପୂର୍ଣ୍ଣତାପ $\Delta_r H^0 = \text{_____ kJ}$ ।

(ନିକଟତମ ପୂର୍ଣ୍ଣସଂଖ୍ୟାରେ ପରିଣତ କର)

Response Type : Numeric

Evaluation Required For SA : Yes

Show Word Count : Yes

Answers Type : Equal

Text Areas : PlainText

Possible Answers :

100

Question Number : 55 **Question Id :** 8643512845 **Question Type :** SA

Correct Marks : 4 **Wrong Marks :** 0

The oxygen dissolved in water exerts a partial pressure of 20 kPa in the vapour above water.

The molar solubility of oxygen in water is $\text{_____} \times 10^{-5} \text{ mol dm}^{-3}$.

(Round off to the Nearest Integer).

[Given : Henry's law constant = $K_H = 8.0 \times 10^4 \text{ kPa}$ for O_2 .

Density of water with dissolved oxygen = 1.0 kg dm^{-3}]

Response Type : Numeric

Evaluation Required For SA : Yes

Show Word Count : Yes

Answers Type : Equal

Text Areas : PlainText

Possible Answers :

100

Question Number : 55 **Question Id :** 8643512845 **Question Type :** SA

Correct Marks : 4 **Wrong Marks :** 0

ଜଳରେ ଦ୍ରବିତ ଅକ୍ସିଜେନ୍ 20 kPa ଆଂଶିକ ଚାପ ଜଳ ଉପର ବାଷ୍ପରେ ପ୍ରୟୋଗ କରେ । ଅକ୍ସିଜେନ୍ର ଜଳୀୟ ମୋଲାର

ଦ୍ରବଣୀୟତା $\text{_____} \times 10^{-5} \text{ mol dm}^{-3}$ ।

(ନିକଟତମ ପୂର୍ଣ୍ଣସଂଖ୍ୟାରେ ପରିଣତ କର)

[ଦତ୍ତ : ହେନେରିକ ନିୟମ ସ୍ଥିରାଙ୍କ = $K_H = 8.0 \times 10^4 \text{ kPa}$ ଅକ୍ସିଜେନ୍ ପାଇଁ ଦ୍ରବିତ ଅକ୍ସିଜେନ୍ ସହିତ ଜଳର ସାନ୍ଦ୍ରତା = 1.0 kg dm^{-3}]

Response Type : Numeric

Evaluation Required For SA : Yes

Show Word Count : Yes

Answers Type : Equal

Text Areas : PlainText

Possible Answers :

100

Question Number : 56 Question Id : 8643512846 Question Type : SA

Correct Marks : 4 Wrong Marks : 0

0.01 moles of a weak acid HA ($K_a = 2.0 \times 10^{-6}$) is dissolved in 1.0 L of 0.1 M HCl solution.

The degree of dissociation of HA is _____ $\times 10^{-5}$ (Round off to the Nearest Integer).

[Neglect volume change on adding HA.

Assume degree of dissociation $\ll 1$]

Response Type : Numeric

Evaluation Required For SA : Yes

Show Word Count : Yes

Answers Type : Equal

Text Areas : PlainText

Possible Answers :

100

Question Number : 56 Question Id : 8643512846 Question Type : SA

Correct Marks : 4 Wrong Marks : 0

0.01 ମୋଲସର ଏକ ଦୁର୍ବଳ ଅମ୍ଳ HA ($K_a = 2.0 \times 10^{-6}$) 1.0 L of 0.1 M HCl ଦ୍ରବଣରେ ଦ୍ରବିତ ହୋଇଅଛି ।

HA ର ଅଣୁ ପୃଥକୀକରଣ ମାତ୍ରା _____ $\times 10^{-5}$ ।

(ନିକଟତମ ପୂର୍ଣ୍ଣସଂଖ୍ୟାରେ ପରିଣତ କର)

[HA ମିଶ୍ରଣଦ୍ୱାରା ଆୟତନ ପରିବର୍ତ୍ତନକୁ ଅଣଦେଖା କର, ଅଣୁ ପୃଥକୀକରଣ ମାତ୍ରା $\ll 1$ ଧରାଯାଉ]

Response Type : Numeric

Evaluation Required For SA : Yes

Show Word Count : Yes

Answers Type : Equal

Text Areas : PlainText

Possible Answers :

100

Question Number : 57 Question Id : 8643512847 Question Type : SA

Correct Marks : 4 Wrong Marks : 0

15 mL of aqueous solution of Fe^{2+} in acidic medium completely reacted with 20 mL of

0.03 M aqueous $\text{Cr}_2\text{O}_7^{2-}$. The molarity of the Fe^{2+} solution is _____ $\times 10^{-2}$ M. (Round

off to the Nearest Integer).

Response Type : Numeric

Evaluation Required For SA : Yes

Show Word Count : Yes

Answers Type : Equal

Text Areas : PlainText

Possible Answers :

100

Question Number : 57 Question Id : 8643512847 Question Type : SA**Correct Marks : 4 Wrong Marks : 0**

Fe^{2+} ର 15 mL ଜଳୀୟ ଦ୍ରବଣ ଅମ୍ଳୀୟ ମିଡ଼ିୟମରେ 20 mL 0.03 M ଜଳୀୟ $\text{Cr}_2\text{O}_7^{2-}$ ଦ୍ରବଣ ଦ୍ୱାରା ପ୍ରଶମିତ ହୋଇଥାଏ । Fe^{2+} ଦ୍ରବଣର ମୋଲାରଟି ହେଉଛି _____ $\times 10^{-2}$ M ।

(ନିକଟତମ ପୂର୍ଣ୍ଣସଂଖ୍ୟାରେ ପରିଣତ କର)

Response Type : Numeric**Evaluation Required For SA : Yes****Show Word Count : Yes****Answers Type : Equal****Text Areas : PlainText****Possible Answers :**

100

Question Number : 58 Question Id : 8643512848 Question Type : SA**Correct Marks : 4 Wrong Marks : 0**

For a certain first order reaction 32% of the reactant is left after 570 s. The rate constant of this reaction is _____ $\times 10^{-3}$ s^{-1} . (Round off to the Nearest Integer).

[Given : $\log_{10}2 = 0.301$, $\ln 10 = 2.303$]**Response Type : Numeric****Evaluation Required For SA : Yes****Show Word Count : Yes****Answers Type : Equal****Text Areas : PlainText****Possible Answers :**

100

Question Number : 58 Question Id : 8643512848 Question Type : SA**Correct Marks : 4 Wrong Marks : 0**

ଏକ ପ୍ରଥମ କ୍ରମ ପ୍ରତିକ୍ରିୟାରେ 570 s ସେକେଣ୍ଡ ସମୟ ପରେ 32% ପ୍ରତିକାରକ ପ୍ରତିକ୍ରିୟା ନକରି ରହିଯାଏ । ଉକ୍ତ ପ୍ରତିକ୍ରିୟାର ପ୍ରତିକ୍ରିୟା ହାର ସ୍ଥିରାଙ୍କ ହେଉଛି _____ $\times 10^{-3}$ s^{-1} । (ନିକଟତମ ପୂର୍ଣ୍ଣସଂଖ୍ୟାରେ ପରିଣତ କର)

[ଦତ୍ତ : $\log_{10}2 = 0.301$, $\ln 10 = 2.303$]**Response Type : Numeric****Evaluation Required For SA : Yes****Show Word Count : Yes****Answers Type : Equal****Text Areas : PlainText****Possible Answers :**

100

Question Number : 59 Question Id : 8643512849 Question Type : SA

Correct Marks : 4 Wrong Marks : 0

The reaction of white phosphorus on boiling with alkali in inert atmosphere resulted in the formation of product 'A'. The reaction of 1 mol of 'A' with excess of AgNO_3 in aqueous medium gives _____ mol(s) of Ag. (Round off to the Nearest Integer).

Response Type : Numeric

Evaluation Required For SA : Yes

Show Word Count : Yes

Answers Type : Equal

Text Areas : PlainText

Possible Answers :

100

Question Number : 59 Question Id : 8643512849 Question Type : SA

Correct Marks : 4 Wrong Marks : 0

ଧଳା ଫସଫରସକୁ କ୍ଷାର ସହ ନିଷ୍ପିୟ ପରିଦେଶରେ ଫୁଟାଇଲେ ଉତ୍ପାଦ 'A' ଗଠନ କରିଥାଏ । ଜଳୀୟ ମିଡ଼ିକ୍ସନ୍‌ରେ ଅତ୍ୟଧିକ AgNO_3 ସହିତ 1 mol A ପ୍ରତିକ୍ରିୟା କରି _____ ମୋଲ୍ Ag ଦେଇଥାଏ ।

(ନିକଟତମ ପୂର୍ଣ୍ଣସଂଖ୍ୟାରେ ପରିଣତ କର)

Response Type : Numeric

Evaluation Required For SA : Yes

Show Word Count : Yes

Answers Type : Equal

Text Areas : PlainText

Possible Answers :

100

Question Number : 60 Question Id : 8643512850 Question Type : SA

Correct Marks : 4 Wrong Marks : 0

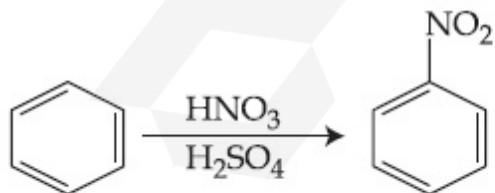

In the above reaction, 3.9 g of benzene on nitration gives 4.92 g of nitrobenzene. The percentage yield of nitrobenzene in the above reaction is _____%. (Round off to the Nearest Integer).

(Given atomic mass : C : 12.0 u, H : 1.0 u, O : 16.0 u, N : 14.0 u)

Response Type : Numeric

Evaluation Required For SA : Yes

Show Word Count : Yes

Answers Type : Equal

Text Areas : PlainText

Possible Answers :

100

Question Number : 60 **Question Id :** 8643512850 **Question Type :** SA

Correct Marks : 4 **Wrong Marks :** 0

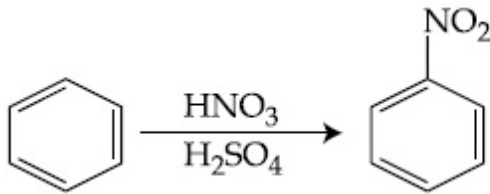

ଉପରୋକ୍ତ ପ୍ରତିକ୍ରିୟାରେ, 3.9 ଗ୍ରାମ୍ ବେଞ୍ଜିନ୍ ନାଇଟ୍ରେସନ୍ ଦ୍ୱାରା 4.92 g ନାଇଟ୍ରୋବେଞ୍ଜିନ୍ ଉତ୍ପନ୍ନ କରେ, ଉପରୋକ୍ତ ପ୍ରତିକ୍ରିୟାରେ ନାଇଟ୍ରୋବେଞ୍ଜିନ୍ର ଶତକଡ଼ା ଉତ୍ପାଦ ଅଟେ _____% ।

(ନିକଟତମ ପୂର୍ଣ୍ଣସଂଖ୍ୟାରେ ପରିଣତ କର)

(ଦତ୍ତ : ପରମାଣବିକ ବସ୍ତୁତ୍ୱ C : 12.0 u, H : 1.0 u, O : 16.0 u, N : 14.0 u)

Response Type : Numeric

Evaluation Required For SA : Yes

Show Word Count : Yes

Answers Type : Equal

Text Areas : PlainText

Possible Answers :

100

Mathematics Section A

Section Id :	864351191
Section Number :	5
Section type :	Online
Mandatory or Optional :	Mandatory
Number of Questions :	20
Number of Questions to be attempted :	20
Section Marks :	80
Mark As Answered Required? :	Yes
Sub-Section Number :	1
Sub-Section Id :	864351191
Question Shuffling Allowed :	Yes

Question Number : 61 **Question Id :** 8643512851 **Question Type :** MCQ **Option Shuffling :** Yes Is

Question Mandatory : No

Correct Marks : 4 Wrong Marks : 1

In a school, there are three types of games to be played. Some of the students play two types of games, but none play all the three games. Which Venn diagrams can justify the above statement ?

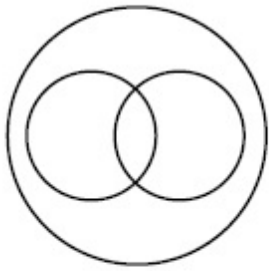

P

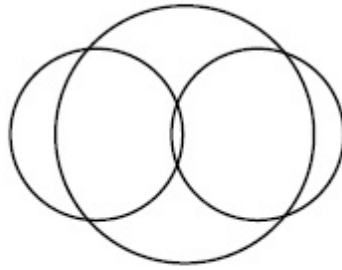

Q

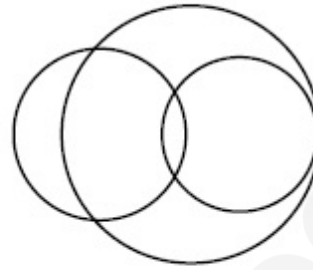

R

Options :

8643518551. P and Q

8643518552. P and R

8643518553. Q and R

8643518554. None of these

Question Number : 61 Question Id : 8643512851 Question Type : MCQ Option Shuffling : Yes Is

Question Mandatory : No

Correct Marks : 4 Wrong Marks : 1

ଗୋଟିଏ ସ୍କୁଲରେ ତିନିପ୍ରକାରର ଖେଳ ଖେଳାଯାଏ । କେତେକ ଛାତ୍ର ଦୁଇପ୍ରକାରର ଖେଳ ଖେଳନ୍ତି, କିନ୍ତୁ କୌଣସି ଛାତ୍ର ତିନିଗୋଟିଯାକ ଖେଳ ଖେଳନ୍ତି ନାହିଁ । କେଉଁ ଭେନ୍ ଚିତ୍ରଟି ଉପରୋକ୍ତ ଉଚ୍ଚତର ଯଥାର୍ଥ କରୁଛି ?

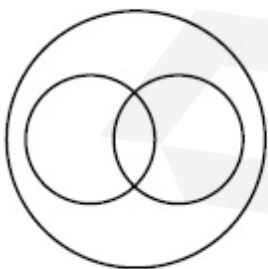

P

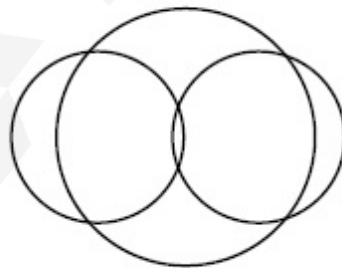

Q

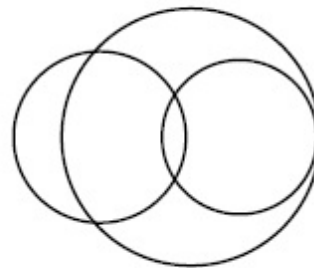

R

Options :

8643518551. P ଏବଂ Q

8643518552. P ଏବଂ R

8643518553. Q ଏବଂ R

8643518554. ଏହା ମଧ୍ୟରୁ କେଉଁଟି ନୁହେଁ

Question Number : 62 Question Id : 8643512852 Question Type : MCQ Option Shuffling : Yes Is Question Mandatory : No

Correct Marks : 4 Wrong Marks : 1

The area of the triangle with vertices $A(z)$, $B(iz)$ and $C(z+iz)$ is :

Options :

8643518555. $\frac{1}{2} |z + iz|^2$ 8643518556. $\frac{1}{2} |z|^2$ 8643518557. $\frac{1}{2}$

8643518558. 1

Question Number : 62 Question Id : 8643512852 Question Type : MCQ Option Shuffling : Yes Is Question Mandatory : No

Correct Marks : 4 Wrong Marks : 1

$A(z)$, $B(iz)$ ଏବଂ $C(z+iz)$ ଶୀର୍ଷବିନ୍ଦୁ ଥିବା ତ୍ରିଭୁଜର କ୍ଷେତ୍ରଫଳ ଅଟେ :

Options :

8643518555. $\frac{1}{2} |z + iz|^2$ 8643518556. $\frac{1}{2} |z|^2$ 8643518557. $\frac{1}{2}$

8643518558. 1

Question Number : 63 Question Id : 8643512853 Question Type : MCQ Option Shuffling : Yes Is Question Mandatory : No

Correct Marks : 4 Wrong Marks : 1

If $A = \begin{pmatrix} 0 & \sin\alpha \\ \sin\alpha & 0 \end{pmatrix}$ and $\det\left(A^2 - \frac{1}{2}I\right) = 0$, then a possible value of α is :

Options :

8643518559. $\frac{\pi}{4}$ 8643518560. $\frac{\pi}{3}$ 8643518561. $\frac{\pi}{6}$ 8643518562. $\frac{\pi}{2}$

Question Number : 63 Question Id : 8643512853 Question Type : MCQ Option Shuffling : Yes Is Question Mandatory : No

Correct Marks : 4 Wrong Marks : 1

ଯଦି $A = \begin{pmatrix} 0 & \sin\alpha \\ \sin\alpha & 0 \end{pmatrix}$ ଏବଂ $\det\left(A^2 - \frac{1}{2}I\right) = 0$ ହୁଏ, ତେବେ α ର ଏକ ସମ୍ଭାବ୍ୟ ମୂଲ୍ୟ ଅଟେ :

Options :

8643518559. $\frac{\pi}{4}$ 8643518560. $\frac{\pi}{3}$ 8643518561. $\frac{\pi}{6}$ 8643518562. $\frac{\pi}{2}$

Question Number : 64 Question Id : 8643512854 Question Type : MCQ Option Shuffling : Yes Is Question Mandatory : No

Correct Marks : 4 Wrong Marks : 1

The system of equations $kx + y + z = 1$, $x + ky + z = k$ and $x + y + zk = k^2$ has no solution if k is equal to :

Options :

8643518563. 0

8643518564. 1

8643518565. -1

8643518566. -2

Question Number : 64 Question Id : 8643512854 Question Type : MCQ Option Shuffling : Yes Is Question Mandatory : No

Correct Marks : 4 Wrong Marks : 1

$kx + y + z = 1$, $x + ky + z = k$ ଏବଂ $x + y + zk = k^2$ ସହ ସମାକରଣ (ସମୂହ) ର କୌଣସି ସମାଧାନ ନାହିଁ ଯଦି k ର ମୂଲ୍ୟ ସମାନ :

Options :

8643518563. 0

8643518564. 1

8643518565. -1

8643518566. -2

Question Number : 65 Question Id : 8643512855 Question Type : MCQ Option Shuffling : Yes Is Question Mandatory : No

Correct Marks : 4 Wrong Marks : 1

Team 'A' consists of 7 boys and n girls and Team 'B' has 4 boys and 6 girls. If a total of 52 single matches can be arranged between these two teams when a boy plays against a boy and a girl plays against a girl, then n is equal to :

Options :

8643518567. 2

8643518568. 4

8643518569. 5

8643518570. 6

Question Number : 65 Question Id : 8643512855 Question Type : MCQ Option Shuffling : Yes Is Question Mandatory : No

Correct Marks : 4 Wrong Marks : 1

ଟିମ୍ (ଦଳ) 'A' ରେ 7 ଜଣ ବାଳକ ଏବଂ n ଜଣ ବାଳିକା ଏବଂ ଟିମ୍ (ଦଳ) 'B' ରେ 4 ଜଣ ବାଳକ ଏବଂ 6 ଜଣ ବାଳିକା ଅଛନ୍ତି । ଯଦି ଏହି ଦୁଇ ଦଳ ମଧ୍ୟରେ ମୋଟରେ 52 ଗୋଟି ଖେଳ (ପ୍ରତିଯୋଗିତା) ର ଆୟୋଜନ କରାଯାଏ ଯେତେବେଳେ ଗୋଟିଏ ବାଳକ (ପୁଅ) ଆଉ ଗୋଟିଏ ବାଳକ (ପୁଅ) ଓ ଗୋଟିଏ ବାଳିକା ଆଉ ଗୋଟିଏ ବାଳିକା ବିରୁଦ୍ଧରେ ଖେଳିବେ, ତେବେ n ର ମୂଲ୍ୟ ସମାନ :

Options :

8643518567. 2

8643518568. 4

8643518569. 5

8643518570. 6

Question Number : 66 Question Id : 8643512856 Question Type : MCQ Option Shuffling : Yes Is Question Mandatory : No

Correct Marks : 4 Wrong Marks : 1

If the fourth term in the expansion of $(x + x^{\log_2 x})^7$ is 4480, then the value of x where $x \in \mathbb{N}$ is equal to :

Options :

8643518571. 1

8643518572. 2

8643518573. 3

8643518574. 4

Question Number : 66 Question Id : 8643512856 Question Type : MCQ Option Shuffling : Yes Is Question Mandatory : No

Correct Marks : 4 Wrong Marks : 1

$(x + x^{\log_2 x})^7$ ର ପ୍ରସାରଣ (ବିସ୍ତାର) ରେ ଯଦି ଚତୁର୍ଥ ପଦଟି 4480 ହୁଏ, (ଯେଉଁଠି $x \in \mathbb{N}$) ତେବେ x ର ମୂଲ୍ୟ ସମୀନ

_____ 1

Options :

8643518571. 1

8643518572. 2

8643518573. 3

8643518574. 4

Question Number : 67 Question Id : 8643512857 Question Type : MCQ Option Shuffling : Yes Is Question Mandatory : No

Correct Marks : 4 Wrong Marks : 1

The value of $4 + \frac{1}{5 + \frac{1}{4 + \frac{1}{5 + \frac{1}{4 + \dots \infty}}}}$ is :

Options :

8643518575. $2 + \frac{2}{5}\sqrt{30}$ 8643518576. $2 + \frac{4}{\sqrt{5}}\sqrt{30}$ 8643518577. $5 + \frac{2}{5}\sqrt{30}$ 8643518578. $4 + \frac{4}{\sqrt{5}}\sqrt{30}$

Question Number : 67 Question Id : 8643512857 Question Type : MCQ Option Shuffling : Yes Is

Question Mandatory : No

Correct Marks : 4 Wrong Marks : 1

$$4 + \frac{1}{5 + \frac{1}{4 + \frac{1}{5 + \frac{1}{4 + \dots \infty}}}}$$

ର ମୂଲ୍ୟ(ମାନ) ଅଟେ :

Options :

$$2 + \frac{2}{5}\sqrt{30}$$

8643518575.

$$2 + \frac{4}{\sqrt{5}}\sqrt{30}$$

8643518576.

$$5 + \frac{2}{5}\sqrt{30}$$

8643518577.

$$4 + \frac{4}{\sqrt{5}}\sqrt{30}$$

8643518578.

Question Number : 68 Question Id : 8643512858 Question Type : MCQ Option Shuffling : Yes Is

Question Mandatory : No

Correct Marks : 4 Wrong Marks : 1

If $\cot^{-1}(\alpha) = \cot^{-1}2 + \cot^{-1}8 + \cot^{-1}18 + \cot^{-1}32 + \dots$ upto 100 terms, then α is :

Options :

8643518579. 1.00

8643518580. 1.01

8643518581. 1.02

8643518582. 1.03

Question Number : 68 Question Id : 8643512858 Question Type : MCQ Option Shuffling : Yes Is

Question Mandatory : No

Correct Marks : 4 Wrong Marks : 1

ଯଦି $\cot^{-1}(\alpha) = \cot^{-1}2 + \cot^{-1}8 + \cot^{-1}18 + \cot^{-1}32 + \dots + 100$ ତମ ପଦ ପର୍ଯ୍ୟନ୍ତ, ତେବେ α ଅଟେ :

Options :

8643518579. 1.00

8643518580. 1.01

8643518581. 1.02

8643518582. 1.03

Question Number : 69 Question Id : 8643512859 Question Type : MCQ Option Shuffling : Yes Is Question Mandatory : No

Correct Marks : 4 Wrong Marks : 1

The inverse of $y = 5^{\log x}$ is :

Options :

8643518583. $x = 5^{\frac{1}{\log y}}$

8643518584. $x = y^{\frac{1}{\log 5}}$

8643518585. $x = 5^{\log y}$

8643518586. $x = y^{\log 5}$

Question Number : 69 Question Id : 8643512859 Question Type : MCQ Option Shuffling : Yes Is Question Mandatory : No

Correct Marks : 4 Wrong Marks : 1

$y = 5^{\log x}$ ର ପ୍ରତିଲୋମ (ଉଲଟା ଫଳନ) ଅଟେ :

Options :

8643518583. $x = 5^{\frac{1}{\log y}}$

8643518584. $x = y^{\frac{1}{\log 5}}$

8643518585. $x = 5^{\log y}$

8643518586. $x = y^{\log 5}$

Question Number : 70 Question Id : 8643512860 Question Type : MCQ Option Shuffling : Yes Is Question Mandatory : No

Correct Marks : 4 Wrong Marks : 1

The value of $\lim_{x \rightarrow 0^+} \frac{\cos^{-1}(x - [x]^2) \cdot \sin^{-1}(x - [x]^2)}{x - x^3}$, where $[x]$ denotes the greatest

integer $\leq x$ is :

Options :

8643518587. $\frac{\pi}{4}$

8643518588. 0

8643518589. $\frac{\pi}{2}$

8643518590. π

Question Number : 70 Question Id : 8643512860 Question Type : MCQ Option Shuffling : Yes Is Question Mandatory : No

Correct Marks : 4 Wrong Marks : 1

$\lim_{x \rightarrow 0^+} \frac{\cos^{-1}(x - [x]^2) \cdot \sin^{-1}(x - [x]^2)}{x - x^3}$, (ଯେଉଁଠାରେ $[x]$ ର ଅର୍ଥ ସର୍ବାଧିକ ପୂର୍ଣ୍ଣସଂଖ୍ୟା $\leq x$) ର ମୂଲ୍ୟ

ଅଟେ :

Options :

8643518587. $\frac{\pi}{4}$

8643518588. 0

8643518589. $\frac{\pi}{2}$ 8643518590. π

Question Number : 71 Question Id : 8643512861 Question Type : MCQ Option Shuffling : Yes Is Question Mandatory : No

Correct Marks : 4 Wrong Marks : 1

Which of the following statements is incorrect for the function $g(\alpha)$ for $\alpha \in \mathbb{R}$ such that

$$g(\alpha) = \int_{\frac{\pi}{6}}^{\frac{\pi}{3}} \frac{\sin^{\alpha} x}{\cos^{\alpha} x + \sin^{\alpha} x} dx$$

Options :

8643518591. $g(\alpha)$ is a strictly increasing function8643518592. $g(\alpha)$ is a strictly decreasing function8643518593. $g(\alpha)$ has an inflection point at $\alpha = -\frac{1}{2}$ 8643518594. $g(\alpha)$ is an even function

Question Number : 71 Question Id : 8643512861 Question Type : MCQ Option Shuffling : Yes Is Question Mandatory : No

Correct Marks : 4 Wrong Marks : 1

ନିମ୍ନକଥନ ମାନକ ମଧ୍ୟରୁ, ଫଳନ $g(\alpha)$, ($\alpha \in \mathbb{R}$) ଯେପରିକି $g(\alpha) = \int_{\frac{\pi}{6}}^{\frac{\pi}{3}} \frac{\sin^{\alpha} x}{\cos^{\alpha} x + \sin^{\alpha} x} dx$ ପାଇଁ କେଉଁ କଥନଟି

ଅସତ୍ୟ ଅଟେ ?

Options :

8643518591. $g(\alpha)$ ଦୃଢ଼ ଭାବରେ ବର୍ଦ୍ଧିତ ଫଳନ

8643518592. $g(\alpha)$ ଦୃଢ଼ ଭାବରେ ହ୍ରାସିତ ଫଳନ

8643518593. $g(\alpha)$ ର $\alpha = -\frac{1}{2}$ ରେ ଏକ ବକ୍ରିକରଣ ବିନ୍ଦୁ ଅଛି ।

8643518594. $g(\alpha)$ ଏକ ଯୁଗ୍ମ ଫଳନ

Question Number : 72 Question Id : 8643512862 Question Type : MCQ Option Shuffling : Yes Is Question Mandatory : No

Correct Marks : 4 Wrong Marks : 1

Which of the following is true for $y(x)$ that satisfies the differential equation

$$\frac{dy}{dx} = xy - 1 + x - y ; y(0) = 0 :$$

Options :

8643518595. $y(1) = e^{-\frac{1}{2}} - 1$

8643518596. $y(1) = e^{\frac{1}{2}} - 1$

8643518597. $y(1) = e^{\frac{1}{2}} - e^{-\frac{1}{2}}$

8643518598. $y(1) = 1$

Question Number : 72 Question Id : 8643512862 Question Type : MCQ Option Shuffling : Yes Is Question Mandatory : No

Correct Marks : 4 Wrong Marks : 1

ନିମ୍ନ ମଧ୍ୟରୁ କେଉଁଟି $y(x)$ ପାଇଁ ସତ ? ଯେପରିକି $y(x)$ $\frac{dy}{dx} = xy - 1 + x - y ; y(0) = 0$, ଅବକଳ ସମୀକରଣଟିକୁ

ସିଦ୍ଧ କରେ ।

Options :

8643518595. $y(1) = e^{-\frac{1}{2}} - 1$

8643518596. $y(1) = e^{\frac{1}{2}} - 1$

$$y(1) = e^{\frac{1}{2}} - e^{-\frac{1}{2}}$$

8643518597.

$$y(1) = 1$$

8643518598.

Question Number : 73 Question Id : 8643512863 Question Type : MCQ Option Shuffling : Yes Is Question Mandatory : No

Correct Marks : 4 Wrong Marks : 1

In a triangle PQR, the co-ordinates of the points P and Q are $(-2, 4)$ and $(4, -2)$ respectively. If the equation of the perpendicular bisector of PR is $2x - y + 2 = 0$, then the centre of the circumcircle of the ΔPQR is :

Options :

8643518599. $(1, 4)$ 8643518600. $(0, 2)$ 8643518601. $(-1, 0)$ 8643518602. $(-2, -2)$

Question Number : 73 Question Id : 8643512863 Question Type : MCQ Option Shuffling : Yes Is Question Mandatory : No

Correct Marks : 4 Wrong Marks : 1

PQR ତ୍ରିଭୁଜରେ P ଏବଂ Q ବିନ୍ଦୁର ସ୍ଥାନାଙ୍କ ଯଥାକ୍ରମେ $(-2, 4)$ ଏବଂ $(4, -2)$ । ଯଦି PR ର ଲମ୍ବ ସମଦ୍ୱିଖଣ୍ଡକର ସମୀକରଣ $2x - y + 2 = 0$ ହୁଏ, ତେବେ ΔPQR ର ପରିବୃତ୍ତର କେନ୍ଦ୍ର ଅଟେ :

Options :

8643518599. $(1, 4)$ 8643518600. $(0, 2)$ 8643518601. $(-1, 0)$ 8643518602. $(-2, -2)$

Question Number : 74 Question Id : 8643512864 Question Type : MCQ Option Shuffling : Yes Is

Question Mandatory : No

Correct Marks : 4 Wrong Marks : 1

The line $2x - y + 1 = 0$ is a tangent to the circle at the point $(2, 5)$ and the centre of the circle lies on $x - 2y = 4$. Then, the radius of the circle is :

Options :

8643518603. $5\sqrt{3}$

8643518604. $5\sqrt{4}$

8643518605. $4\sqrt{5}$

8643518606. $3\sqrt{5}$

Question Number : 74 Question Id : 8643512864 Question Type : MCQ Option Shuffling : Yes Is

Question Mandatory : No

Correct Marks : 4 Wrong Marks : 1

ରେଖା $2x - y + 1 = 0$ ଚି ବୃତ୍ତ ପ୍ରତି $(2, 5)$ ବିନ୍ଦୁଠାରେ ଏକ ସ୍ପର୍ଶକ ଏବଂ ବୃତ୍ତର କେନ୍ଦ୍ର ରେଖା $x - 2y = 4$ ଉପରେ ଅବସ୍ଥିତ । ତେବେ ବୃତ୍ତର ବ୍ୟାସାର୍ଦ୍ଧ ଅଟେ :

Options :

8643518603. $5\sqrt{3}$

8643518604. $5\sqrt{4}$

8643518605. $4\sqrt{5}$

8643518606. $3\sqrt{5}$

Question Number : 75 Question Id : 8643512865 Question Type : MCQ Option Shuffling : Yes Is

Question Mandatory : No

Correct Marks : 4 Wrong Marks : 1

Choose the incorrect statement about the two circles whose equations are given below :

$x^2 + y^2 - 10x - 10y + 41 = 0$ and

$x^2 + y^2 - 16x - 10y + 80 = 0$

Options :

8643518607. Circles have two intersection points.
8643518608. Both circles pass through the centre of each other.
8643518609. Both circles' centres lie inside region of one another.
8643518610. Distance between two centres is the average of radii of both the circles.

Question Number : 75 Question Id : 8643512865 Question Type : MCQ Option Shuffling : Yes Is Question Mandatory : No

Correct Marks : 4 Wrong Marks : 1

ଦୁଇଟି ବୃତ୍ତ ଯାହାର ସମୀକରଣ $x^2 + y^2 - 10x - 10y + 41 = 0$ ଏବଂ $x^2 + y^2 - 16x - 10y + 80 = 0$ ଦିଆଯାଇଛି । ଏମାନଙ୍କ ସମ୍ବନ୍ଧରେ ଅସତ୍ୟ କଥନଟିକୁ ବାଛ (ଚୟନ କର) ।

Options :

8643518607. ବୃତ୍ତଗୁଡ଼ିକର ଦୁଇଟି ଛେଦ ବିନ୍ଦୁ ଅଛି ।
8643518608. ଉଭୟ ବୃତ୍ତ ଜଣେ ଅନ୍ୟଜଣର କେନ୍ଦ୍ର ବିନ୍ଦୁ ମଧ୍ୟ ଦେଇ ଗତି କରେ ।
8643518609. ଉଭୟ ବୃତ୍ତର କେନ୍ଦ୍ର ମଧ୍ୟରୁ ଜଣଙ୍କର କେନ୍ଦ୍ର ଅନ୍ୟର ଅଭ୍ୟନ୍ତର ଭାଗରେ ଅବସ୍ଥିତ ।
8643518610. କେନ୍ଦ୍ରଦ୍ୱୟ ମଧ୍ୟବର୍ତ୍ତୀ ଦୂରତ୍ୱ ଉଭୟ ବ୍ୟାସାର୍ଦ୍ଧର ହାରାହାରି ମୂଲ୍ୟ ।

Question Number : 76 Question Id : 8643512866 Question Type : MCQ Option Shuffling : Yes Is Question Mandatory : No

Correct Marks : 4 Wrong Marks : 1

The equation of the plane which contains the y -axis and passes through the point (1, 2, 3) is :

Options :

8643518611. $3x + z = 6$
8643518612. $x + 3z = 10$
8643518613. $x + 3z = 0$
8643518614. $3x - z = 0$

Question Number : 76 Question Id : 8643512866 Question Type : MCQ Option Shuffling : Yes Is Question Mandatory : No

Correct Marks : 4 Wrong Marks : 1

ସମତଳଟିର ସମୀକରଣ, ଯାହା ଉପରେ y -ଅକ୍ଷ ଅବସ୍ଥିତ ଏବଂ ଯାହା ବିନ୍ଦୁ (1, 2, 3) ମଧ୍ୟ ଦେଇ ଗତି କରେ, ତାହା ଅଟେ :

Options :

8643518611. $3x + z = 6$

8643518612. $x + 3z = 10$

8643518613. $x + 3z = 0$

8643518614. $3x - z = 0$

Question Number : 77 Question Id : 8643512867 Question Type : MCQ Option Shuffling : Yes Is Question Mandatory : No

Correct Marks : 4 Wrong Marks : 1

If the Boolean expression $(p \Rightarrow q) \Leftrightarrow (q * (\sim p))$ is a tautology, then the Boolean expression $p * (\sim q)$ is equivalent to :

Options :

8643518615. $P \Rightarrow q$

8643518616. $p \Rightarrow \sim q$

8643518617. $q \Rightarrow P$

8643518618. $\sim q \Rightarrow P$

Question Number : 77 Question Id : 8643512867 Question Type : MCQ Option Shuffling : Yes Is Question Mandatory : No

Correct Marks : 4 Wrong Marks : 1

ଯଦି ବୁଲିଅନ ଉକ୍ତି $(p \Rightarrow q) \Leftrightarrow (q * (\sim p))$ ଏକ ପୁନରୁକ୍ତି (ଟଟୋଲୋଜି) ଅଟେ, ତେବେ ବୁଲିଅନ ଉକ୍ତି $p * (\sim q)$ ସହ ସମତୁଲ୍ୟ ଉକ୍ତିଟି ଅଟେ :

Options :

8643518615. $P \Rightarrow q$

8643518616. $P \Rightarrow \sim Q$

8643518617. $Q \Rightarrow P$

8643518618. $\sim Q \Rightarrow P$

Question Number : 78 Question Id : 8643512868 Question Type : MCQ Option Shuffling : Yes Is Question Mandatory : No

Correct Marks : 4 Wrong Marks : 1

Let $\vec{a} = 2\hat{i} - 3\hat{j} + 4\hat{k}$ and $\vec{b} = 7\hat{i} + \hat{j} - 6\hat{k}$.

If $\vec{r} \times \vec{a} = \vec{r} \times \vec{b}$, $\vec{r} \cdot (\hat{i} + 2\hat{j} + \hat{k}) = -3$, then $\vec{r} \cdot (2\hat{i} - 3\hat{j} + \hat{k})$ is equal to :

Options :

8643518619. 8

8643518620. 10

8643518621. 12

8643518622. 13

Question Number : 78 Question Id : 8643512868 Question Type : MCQ Option Shuffling : Yes Is Question Mandatory : No

Correct Marks : 4 Wrong Marks : 1

ମନେକର $\vec{a} = 2\hat{i} - 3\hat{j} + 4\hat{k}$ ଏବଂ $\vec{b} = 7\hat{i} + \hat{j} - 6\hat{k}$ ଯଦି $\vec{r} \times \vec{a} = \vec{r} \times \vec{b}$,

$\vec{r} \cdot (\hat{i} + 2\hat{j} + \hat{k}) = -3$, ତେବେ $\vec{r} \cdot (2\hat{i} - 3\hat{j} + \hat{k})$ ସମାନ :

Options :

8643518619. 8

8643518620. 10

8643518621. 12

8643518622. 13

Question Number : 79 Question Id : 8643512869 Question Type : MCQ Option Shuffling : Yes Is Question Mandatory : No

Correct Marks : 4 Wrong Marks : 1

Two dices are rolled. If both dices have six faces numbered 1, 2, 3, 5, 7 and 11, then the probability that the sum of the numbers on the top faces is less than or equal to 8 is :

Options :

8643518623. $\frac{5}{12}$

8643518624. $\frac{4}{9}$

8643518625. $\frac{17}{36}$

8643518626. $\frac{1}{2}$

Question Number : 79 Question Id : 8643512869 Question Type : MCQ Option Shuffling : Yes Is Question Mandatory : No

Correct Marks : 4 Wrong Marks : 1

ଦୁଇଟି ପଟ୍ଟାକାଠିକୁ ଗଡ଼ାଇ ଦିଆଗଲା । ଯଦି ଉଭୟ ପଟ୍ଟାକାଠିର ଛଅଟି ପାର୍ଶ୍ୱକୁ 1, 2, 3, 5, 7 ଏବଂ 11 ବୋଲି ଚିହ୍ନିତ କରାଯାଇଥାଏ, ତେବେ ଉଭୟ ପଟ୍ଟାକାଠିର ଉପରିଭାଗର ସଂଖ୍ୟାକୁ ମିଶାଇ 8 ବା ତା ଠାରୁ କମ୍ ସଂଖ୍ୟା ପାଇବାର ସମ୍ଭାବ୍ୟତା ଅଟେ :

Options :

8643518623. $\frac{5}{12}$

8643518624. $\frac{4}{9}$

8643518625. $\frac{17}{36}$

$\frac{1}{2}$

8643518626.

Question Number : 80 Question Id : 8643512870 Question Type : MCQ Option Shuffling : Yes Is Question Mandatory : No

Correct Marks : 4 Wrong Marks : 1

The sum of possible values of x for $\tan^{-1}(x + 1) + \cot^{-1}\left(\frac{1}{x - 1}\right) = \tan^{-1}\left(\frac{8}{31}\right)$ is :

Options :

 $-\frac{33}{4}$

8643518627.

 $-\frac{32}{4}$

8643518628.

 $-\frac{31}{4}$

8643518629.

 $-\frac{30}{4}$

8643518630.

Question Number : 80 Question Id : 8643512870 Question Type : MCQ Option Shuffling : Yes Is Question Mandatory : No

Correct Marks : 4 Wrong Marks : 1

$\tan^{-1}(x + 1) + \cot^{-1}\left(\frac{1}{x - 1}\right) = \tan^{-1}\left(\frac{8}{31}\right)$ ପାଇଁ x ର ସମ୍ଭାବ୍ୟ ମୂଲ୍ୟମାନଙ୍କର ସମଷ୍ଟି ଅଟେ :

Options :

 $-\frac{33}{4}$

8643518627.

 $-\frac{32}{4}$

8643518628.

 $-\frac{31}{4}$

8643518629.

$$-\frac{30}{4}$$

8643518630.

Mathematics Section B

Section Id :	864351192
Section Number :	6
Section type :	Online
Mandatory or Optional :	Mandatory
Number of Questions :	10
Number of Questions to be attempted :	5
Section Marks :	20
Mark As Answered Required? :	Yes
Sub-Section Number :	1
Sub-Section Id :	864351192
Question Shuffling Allowed :	Yes

Question Number : 81 Question Id : 8643512871 Question Type : SA

Correct Marks : 4 Wrong Marks : 0

The maximum value of z in the following equation $z = 6xy + y^2$, where $3x + 4y \leq 100$ and $4x + 3y \leq 75$ for $x \geq 0$ and $y \geq 0$ is _____.

Response Type : Numeric

Evaluation Required For SA : Yes

Show Word Count : Yes

Answers Type : Equal

Text Areas : PlainText

Possible Answers :

100

Question Number : 81 Question Id : 8643512871 Question Type : SA

Correct Marks : 4 Wrong Marks : 0

ସମୀକରଣଟି $z = 6xy + y^2$, ଯେଉଁଠାରେ $3x + 4y \leq 100$ ଏବଂ $4x + 3y \leq 75$ ଏବଂ $x \geq 0$ ଓ $y \geq 0$ । 6୦6୦ z ର ସର୍ବାଧିକ ମୂଲ୍ୟ ଅଟେ _____ ।

Response Type : Numeric

Evaluation Required For SA : Yes

Show Word Count : Yes

Answers Type : Equal

Text Areas : PlainText

Possible Answers :

100

Question Number : 82 Question Id : 8643512872 Question Type : SA

Correct Marks : 4 Wrong Marks : 0

If $A = \begin{bmatrix} 2 & 3 \\ 0 & -1 \end{bmatrix}$, then the value of $\det(A^4) + \det(A^{10} - (\text{Adj}(2A))^{10})$ is equal to _____.

Response Type : Numeric

Evaluation Required For SA : Yes

Show Word Count : Yes

Answers Type : Equal

Text Areas : PlainText

Possible Answers :

100

Question Number : 82 Question Id : 8643512872 Question Type : SA

Correct Marks : 4 Wrong Marks : 0

ଯଦି $A = \begin{bmatrix} 2 & 3 \\ 0 & -1 \end{bmatrix}$, ତେବେ $\det(A^4) + \det(A^{10} - (\text{Adj}(2A))^{10})$ ର ମୂଲ୍ୟ ସମାନ _____ ।

Response Type : Numeric

Evaluation Required For SA : Yes

Show Word Count : Yes

Answers Type : Equal

Text Areas : PlainText

Possible Answers :

100

Question Number : 83 Question Id : 8643512873 Question Type : SA

Correct Marks : 4 Wrong Marks : 0

If $(2021)^{3762}$ is divided by 17, then the remainder is _____.

Response Type : Numeric

Evaluation Required For SA : Yes

Show Word Count : Yes

Answers Type : Equal

Text Areas : PlainText

Possible Answers :

100

Question Number : 83 Question Id : 8643512873 Question Type : SA

Correct Marks : 4 Wrong Marks : 0

ଯଦି $(2021)^{3762}$, 17 ଦ୍ୱାରା ବିଭାଜ୍ୟ, ତେବେ ଭାଗଶେଷଟି ଅଟେ _____ ।

Response Type : Numeric**Evaluation Required For SA :** Yes**Show Word Count :** Yes**Answers Type :** Equal**Text Areas :** PlainText**Possible Answers :**

100

Question Number : 84 **Question Id :** 8643512874 **Question Type :** SA**Correct Marks :** 4 **Wrong Marks :** 0

If the function $f(x) = \frac{\cos(\sin x) - \cos x}{x^4}$ is continuous at each point in its domain and

$$f(0) = \frac{1}{k}, \text{ then } k \text{ is } \underline{\hspace{2cm}}.$$

Response Type : Numeric**Evaluation Required For SA :** Yes**Show Word Count :** Yes**Answers Type :** Equal**Text Areas :** PlainText**Possible Answers :**

100

Question Number : 84 **Question Id :** 8643512874 **Question Type :** SA**Correct Marks :** 4 **Wrong Marks :** 0

ଯଦି ଫଳନ $f(x) = \frac{\cos(\sin x) - \cos x}{x^4}$ ତି ଏହାର ପରିସର କ୍ଷେତ୍ରର ପ୍ରତ୍ୟେକ ବିନ୍ଦୁରେ ଅବିଚ୍ଛିନ୍ନ ଅଟେ ଏବଂ $f(0) = \frac{1}{k}$,

ତେବେ k ଅଟେ $\underline{\hspace{2cm}}$ ।

Response Type : Numeric**Evaluation Required For SA :** Yes**Show Word Count :** Yes**Answers Type :** Equal**Text Areas :** PlainText**Possible Answers :**

100

Question Number : 85 **Question Id :** 8643512875 **Question Type :** SA**Correct Marks :** 4 **Wrong Marks :** 0

If $[\cdot]$ represents the greatest integer function, then the value of

$$\left| \int_0^{\sqrt{\frac{\pi}{2}}} [x^2] - \cos x \, dx \right| \text{ is } \underline{\hspace{2cm}}$$

Response Type : Numeric

Evaluation Required For SA : Yes

Show Word Count : Yes

Answers Type : Equal

Text Areas : PlainText

Possible Answers :

100

Question Number : 85 **Question Id :** 8643512875 **Question Type :** SA

Correct Marks : 4 **Wrong Marks :** 0

ଯଦି $[\cdot]$ ଏକ ସର୍ବାଧିକ ପୂର୍ଣ୍ଣାଙ୍କ ଫଳନକୁ ବୁଝାଏ, ତେବେ $\left| \int_0^{\sqrt{\frac{\pi}{2}}} [x^2] - \cos x \, dx \right|$ ର ମୂଲ୍ୟ ଅଟେ _____ ।

Response Type : Numeric

Evaluation Required For SA : Yes

Show Word Count : Yes

Answers Type : Equal

Text Areas : PlainText

Possible Answers :

100

Question Number : 86 **Question Id :** 8643512876 **Question Type :** SA

Correct Marks : 4 **Wrong Marks :** 0

The minimum distance between any two points P_1 and P_2 while considering point P_1 on one circle and point P_2 on the other circle for the given circles' equations

$$x^2 + y^2 - 10x - 10y + 41 = 0$$

$$x^2 + y^2 - 24x - 10y + 160 = 0 \text{ is } \underline{\hspace{2cm}}.$$

Response Type : Numeric

Evaluation Required For SA : Yes

Show Word Count : Yes

Answers Type : Equal

Text Areas : PlainText

Possible Answers :

100

Question Number : 86 Question Id : 8643512876 Question Type : SA

Correct Marks : 4 Wrong Marks : 0

$$\text{ଦତ୍ତ ବୃତ୍ତ ଦ୍ୱୟ } x^2 + y^2 - 10x - 10y + 41 = 0$$

$$x^2 + y^2 - 24x - 10y + 160 = 0$$

ଯଦି P_1 ଏକ ବୃତ୍ତ ଉପରିସ୍ଥ ବିନ୍ଦୁ ଓ P_2 ଅନ୍ୟ ବୃତ୍ତ ଉପରିସ୍ଥ ବିନ୍ଦୁ ହୁଅନ୍ତି ତେବେ P_1 ଓ P_2 ବିନ୍ଦୁ ମଧ୍ୟରେ ଥିବା ସର୍ବନିମ୍ନ ଦୂରତ୍ୱ ଅଟେ _____ ।

Response Type : Numeric

Evaluation Required For SA : Yes

Show Word Count : Yes

Answers Type : Equal

Text Areas : PlainText

Possible Answers :

100

Question Number : 87 Question Id : 8643512877 Question Type : SA

Correct Marks : 4 Wrong Marks : 0

If the equation of the plane passing through the line of intersection of the planes $2x - 7y + 4z - 3 = 0$, $3x - 5y + 4z + 11 = 0$ and the point $(-2, 1, 3)$ is $ax + by + cz - 7 = 0$, then the value of $2a + b + c - 7$ is _____.

Response Type : Numeric

Evaluation Required For SA : Yes

Show Word Count : Yes

Answers Type : Equal

Text Areas : PlainText

Possible Answers :

100

Question Number : 87 Question Id : 8643512877 Question Type : SA

Correct Marks : 4 Wrong Marks : 0

$2x - 7y + 4z - 3 = 0$, $3x - 5y + 4z + 11 = 0$ ସମତଳ ଦ୍ୱୟର ଛେଦରେଖା ଓ ବିନ୍ଦୁ $(-2, 1, 3)$ ମଧ୍ୟ ଦେଇ ଗତି କରୁଥିବା ସମତଳଟିର ସମୀକରଣ ଯଦି $ax + by + cz - 7 = 0$ ହୁଏ, ତେବେ $2a + b + c - 7$ ର ମୂଲ୍ୟ ଅଟେ _____ ।

Response Type : Numeric

Evaluation Required For SA : Yes

Show Word Count : Yes

Answers Type : Equal

Text Areas : PlainText

Possible Answers :

100

Question Number : 88 Question Id : 8643512878 Question Type : SA

Correct Marks : 4 Wrong Marks : 0

Let there be three independent events E_1 , E_2 and E_3 . The probability that only E_1 occurs is α , only E_2 occurs is β and only E_3 occurs is γ . Let 'p' denote the probability of none of events occurs that satisfies the equations $(\alpha - 2\beta)p = \alpha\beta$ and $(\beta - 3\gamma)p = 2\beta\gamma$. All the given probabilities are assumed to lie in the interval $(0, 1)$.

Then, $\frac{\text{Probability of occurrence of } E_1}{\text{Probability of occurrence of } E_3}$ is equal to _____.

Response Type : Numeric

Evaluation Required For SA : Yes

Show Word Count : Yes

Answers Type : Equal

Text Areas : PlainText

Possible Answers :

100

Question Number : 88 Question Id : 8643512878 Question Type : SA

Correct Marks : 4 Wrong Marks : 0

ମନେକର E_1 , E_2 ଏବଂ E_3 ତିନିଗୋଟି ସ୍ୱତନ୍ତ୍ର (ସ୍ୱାଧୀନ) ଘଟଣା । କେବଳ E_1 ଘଟଣା ଘଟିବାର ସମ୍ଭାବ୍ୟତା α , କେବଳ E_2 ଘଟଣା ଘଟିବାର ସମ୍ଭାବ୍ୟତା β ଓ କେବଳ E_3 ଘଟଣା ଘଟିବାର ସମ୍ଭାବ୍ୟତା γ ଅଟେ । ମନେକର କୌଣସି ଘଟଣା ନ ଘଟିବାର ସମ୍ଭାବ୍ୟତାକୁ p ରୂପେ ସୂଚିତ କରାଯାଏ, ଯାହା $(\alpha - 2\beta)p = \alpha\beta$ ଏବଂ $(\beta - 3\gamma)p = 2\beta\gamma$ ସମୀକରଣଗୁଡ଼ିକୁ ସିଦ୍ଧ କରେ । ମାନିନେବା ଯେ, ସମସ୍ତ ସମ୍ଭାବ୍ୟତା $(0, 1)$ ଅନ୍ତରାଳ ମଧ୍ୟରେ ଅବସ୍ଥିତ ।

ତେବେ, $\frac{E_1 \text{ ଘଟଣା ଘଟିବାର ସମ୍ଭାବ୍ୟତା}}{E_3 \text{ ଘଟଣା ଘଟିବାର ସମ୍ଭାବ୍ୟତା}}$ ସମାନ _____ ।

Response Type : Numeric

Evaluation Required For SA : Yes

Show Word Count : Yes

Answers Type : Equal

Text Areas : PlainText

Possible Answers :

100

Question Number : 89 Question Id : 8643512879 Question Type : SA

Correct Marks : 4 Wrong Marks : 0

If $f(x) = \sin\left(\cos^{-1}\left(\frac{1-2^{2x}}{1+2^{2x}}\right)\right)$ and its first derivative with respect to x is $-\frac{b}{a}\log_e 2$ when

$x=1$, where a and b are integers, then the minimum value of $|a^2-b^2|$ is _____.

Response Type : Numeric

Evaluation Required For SA : Yes

Show Word Count : Yes

Answers Type : Equal

Text Areas : PlainText

Possible Answers :

100

Question Number : 89 **Question Id :** 8643512879 **Question Type :** SA

Correct Marks : 4 **Wrong Marks :** 0

ଯଦି $f(x) = \sin\left(\cos^{-1}\left(\frac{1-2^{2x}}{1+2^{2x}}\right)\right)$ ଏବଂ ଏହି ଫଳନର x ଭିତ୍ତିକ ପ୍ରଥମ ଅବକଳନ $-\frac{b}{a}\log_e 2$ (ଯେତେବେଳେ

$x=1$, a ଓ b ପୂର୍ଣ୍ଣସଂଖ୍ୟା) ତେବେ $|a^2-b^2|$ ର ସର୍ବନିମ୍ନ ମୂଲ୍ୟ ଅଟେ _____ ।

Response Type : Numeric

Evaluation Required For SA : Yes

Show Word Count : Yes

Answers Type : Equal

Text Areas : PlainText

Possible Answers :

100

Question Number : 90 **Question Id :** 8643512880 **Question Type :** SA

Correct Marks : 4 **Wrong Marks :** 0

If $\vec{a} = \alpha \hat{i} + \beta \hat{j} + 3\hat{k}$,

$\vec{b} = -\beta \hat{i} - \alpha \hat{j} - \hat{k}$ and

$\vec{c} = \hat{i} - 2\hat{j} - \hat{k}$

such that $\vec{a} \cdot \vec{b} = 1$ and $\vec{b} \cdot \vec{c} = -3$, then $\frac{1}{3}((\vec{a} \times \vec{b}) \cdot \vec{c})$ is equal to _____.

Response Type : Numeric

Evaluation Required For SA : Yes

Show Word Count : Yes

Answers Type : Equal

Text Areas : PlainText

Possible Answers :

100

Question Number : 90 Question Id : 8643512880 Question Type : SA

Correct Marks : 4 Wrong Marks : 0

$$\vec{a} = \alpha \hat{i} + \beta \hat{j} + 3\hat{k}$$

$$\vec{b} = -\beta \hat{i} - \alpha \hat{j} - \hat{k} \quad \text{ଏବଂ}$$

$$\vec{c} = \hat{i} - 2\hat{j} - \hat{k} \quad \text{ଯେଉଁଠି} \quad \vec{a} \cdot \vec{b} = 1 \quad \text{ଏବଂ} \quad \vec{b} \cdot \vec{c} = -3, \quad \text{ତେବେ} \quad \frac{1}{3}((\vec{a} \times \vec{b}) \cdot \vec{c}) \quad \text{ସମାନ}$$

_____ ।

Response Type : Numeric

Evaluation Required For SA : Yes

Show Word Count : Yes

Answers Type : Equal

Text Areas : PlainText

Possible Answers :

100