

National Testing Agency

Question Paper Name :	B TECH EO 18th March 2021 Shift 1
Subject Name :	B TECH EO
Creation Date :	2021-03-18 14:10:30
Duration :	180
Number of Questions :	90
Total Marks :	300
Display Marks:	Yes

B TECH EO

Group Number :	1
Group Id :	86435175
Group Maximum Duration :	0
Group Minimum Duration :	180
Show Attended Group? :	No
Edit Attended Group? :	No
Break time :	0
Group Marks :	300
Is this Group for Examiner? :	No

Physics Section A

Section Id :	864351445
Section Number :	1
Section type :	Online
Mandatory or Optional :	Mandatory
Number of Questions :	20
Number of Questions to be attempted :	20
Section Marks :	80
Mark As Answered Required? :	Yes
Sub-Section Number :	1
Sub-Section Id :	864351445
Question Shuffling Allowed :	Yes

Question Number : 1 Question Id : 8643516661 Question Type : MCQ Option Shuffling : Yes Is Question Mandatory : No Correct Marks : 4 Wrong Marks : 1

An oil drop of radius 2 mm with a density 3 g cm^{-3} is held stationary under a constant electric field $3.55 \times 10^5 \text{ V m}^{-1}$ in the Millikan's oil drop experiment. What is the number of excess electrons that the oil drop will possess ?

Consider $g = 9.81 \text{ m/s}^2$

Options :

86435119981. 17.3×10^{10}

86435119982. 1.73×10^{10}

86435119983. 1.73×10^{12}

86435119984. 48.8×10^{11}

Question Number : 1 Question Id : 8643516661 Question Type : MCQ Option Shuffling : Yes Is Question Mandatory : No

Correct Marks : 4 Wrong Marks : 1

ମିଲିକାନଙ୍କ ଅଧିକୃତ ପରୀକ୍ଷାର ଏକ ଛିର ବିଦ୍ୟୁତ୍ କ୍ଷେତ୍ର $3.55 \times 10^5 \text{ V m}^{-1}$ ମଧ୍ୟରେ 3 g cm^{-3} ସାନ୍ଦ୍ରତା ସହ 2 mm ବ୍ୟାସାର୍ଦ୍ଧ ବଗିଷ୍ଟ ଗୋଟିଏ ତେଲ ଗୋପାକୁ ଛିର ଭାବରେ ରଖାଯାଇଛି । ତେଲ ଗୋପାଟି କେତେ ସଂଖ୍ୟାର ଅଧିକ ଇଲେକ୍ଟ୍ରନ୍ ଧାରଣ କରିଅଛି ?

(ଧର $g = 9.81 \text{ m/s}^2$)

Options :

86435119981. 17.3×10^{10}

86435119982. 1.73×10^{10}

86435119983. 1.73×10^{12}

86435119984. 48.8×10^{11}

Question Number : 2 Question Id : 8643516662 Question Type : MCQ Option Shuffling : Yes Is Question Mandatory : No

Correct Marks : 4 Wrong Marks : 1

A constant power delivering machine has towed a box, which was initially at rest, along a horizontal straight line. The distance moved by the box in time 't' is proportional to :

Options :

86435119985. $t^{3/2}$

86435119986. $t^{1/2}$ 86435119987. $t^{2/3}$ 86435119988. t

Question Number : 2 Question Id : 8643516662 Question Type : MCQ Option Shuffling : Yes Is Question Mandatory : No

Correct Marks : 4 Wrong Marks : 1

ଭୂସମାନ୍ତର ସରଳରେଖା ଦିଗରେ ପ୍ରାରମ୍ଭରୁ ଛିର ଅବସ୍ଥାରେ ଥିବା ଗୋଟିଏ ବାକ୍ସକୁ ଛିର ଶକ୍ତି ପ୍ରଦାନ କରୁଥିବା ଗୋଟିଏ କଳ (ମେସିନ୍) ଦ୍ୱାରା ବାନ୍ଧି ଚଣାଯାଉଛି । 't' ସମୟରେ, ବାକ୍ସଟି ଦ୍ୱାରା ଅତିକ୍ରାନ୍ତ କରୁଥିବା ଦୂରତା ସମାନୁପାତି ହେଉଛି :

Options :

86435119985. $t^{3/2}$ 86435119986. $t^{1/2}$ 86435119987. $t^{2/3}$ 86435119988. t

Question Number : 3 Question Id : 8643516663 Question Type : MCQ Option Shuffling : Yes Is Question Mandatory : No

Correct Marks : 4 Wrong Marks : 1

Four identical long solenoids A, B, C and D are connected to each other as shown in the figure. If the magnetic field at the center of A is 3 T, the field at the center of C would be : (Assume that the magnetic field is confined within the volume of respective solenoid).

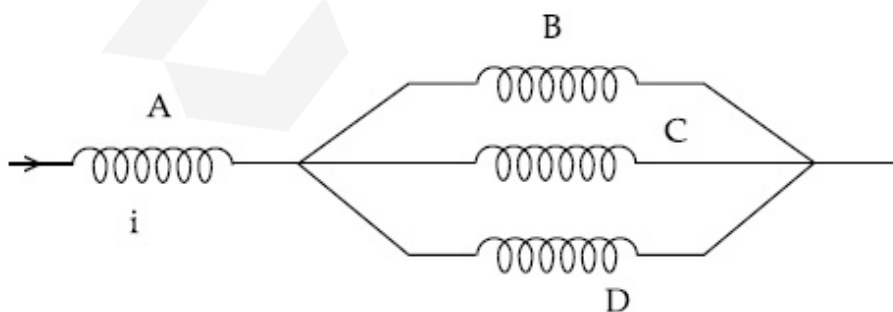

Options :

86435119989. 1 T

86435119990. 9 T

86435119991. 6 T

86435119992. 12 T

Question Number : 3 Question Id : 8643516663 Question Type : MCQ Option Shuffling : Yes Is Question Mandatory : No

Correct Marks : 4 Wrong Marks : 1

ସମାନ ଲମ୍ବ ବିଶିଷ୍ଟ ଚାରିଗୋଟି ସଲିନିଏଡ୍ A, B, C ଏବଂ D କୁ ଚିତ୍ରରେ ଦର୍ଶାଯାଇଥିବା ଅନୁସାରେ ସଂଯୋଗ କରାଯାଇଛି । ଯଦି A ର କେନ୍ଦ୍ରରେ ଚୁମ୍ବକୀୟ କ୍ଷେତ୍ର 3 T ହୁଏ, C ର କେନ୍ଦ୍ରରେ ଚୁମ୍ବକୀୟ କ୍ଷେତ୍ର ହେବ :

(ଧରିନିଅ ଚୁମ୍ବକୀୟ କ୍ଷେତ୍ରଗୁଡ଼ିକ ସଂପୂର୍ଣ୍ଣ ସଲିନିଏଡ୍ ଭିତରେ ସୀମିତ ରହିଛି)

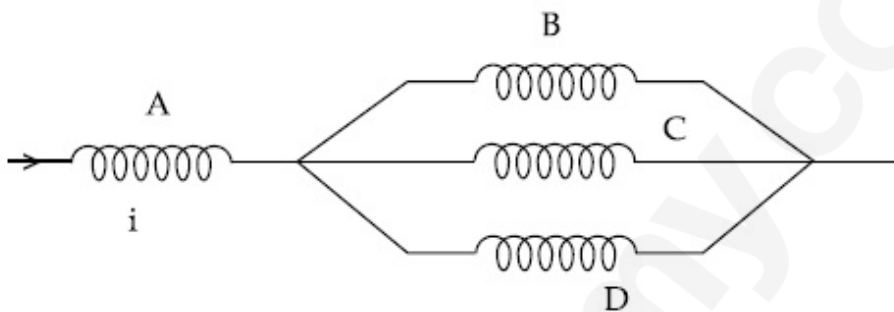

Options :

86435119989. 1 T

86435119990. 9 T

86435119991. 6 T

86435119992. 12 T

Question Number : 4 Question Id : 8643516664 Question Type : MCQ Option Shuffling : Yes Is Question Mandatory : No

Correct Marks : 4 Wrong Marks : 1

The P-V diagram of a diatomic ideal gas system going under cyclic process as shown in figure. The work done during an adiabatic process CD is (use $\gamma = 1.4$) :

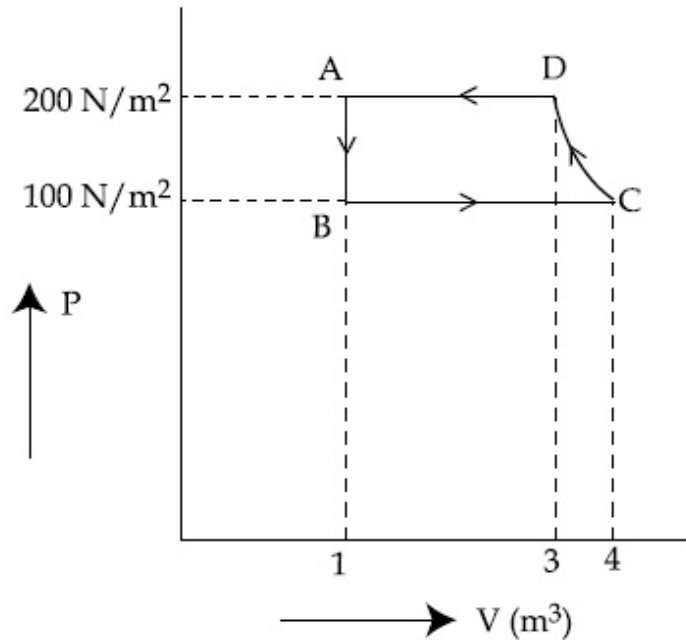

Options :

86435119993. 400 J

86435119994. -500 J

86435119995. 200 J

86435119996. -400 J

Question Number : 4 Question Id : 8643516664 Question Type : MCQ Option Shuffling : Yes Is

Question Mandatory : No

Correct Marks : 4 Wrong Marks : 1

ଚିତ୍ରରେ ଦର୍ଶାଯାଇଥିବା ଅନୁସାରେ ଚକ୍ରିୟ ପ୍ରକ୍ରିୟାରେ ଥିବା ଏକ ଦ୍ଵିପରମାଣୁ ବିଶିଷ୍ଟ ଆଦର୍ଶ ଗ୍ୟାସର P-V ଲେଖଚିତ୍ର ରହିଛି ।

ଏକ ରୁକ୍ଷତାପ ପ୍ରକ୍ରିୟା CD ସମୟରେ ସମ୍ପାଦିତ କାର୍ଯ୍ୟ ଅଟେ :

(ନିଅ : $\gamma = 1.4$)

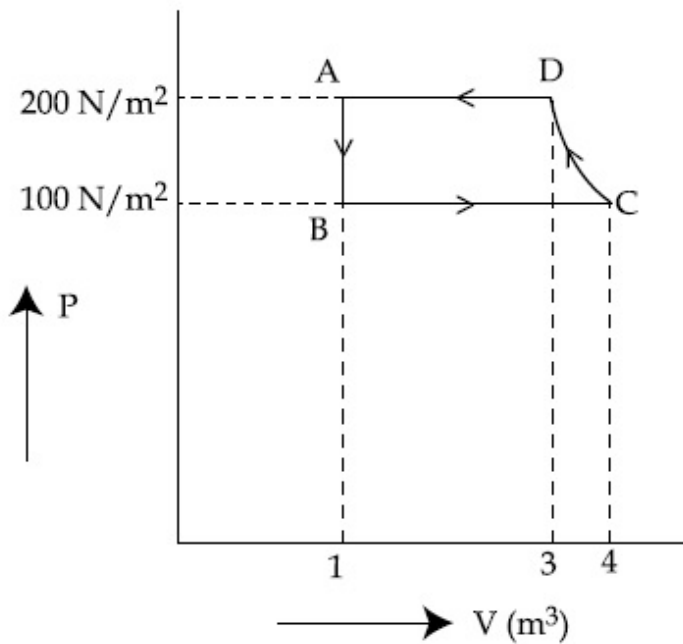

Options :

86435119993. 400 J

86435119994. -500 J

86435119995. 200 J

86435119996. -400 J

Question Number : 5 Question Id : 8643516665 Question Type : MCQ Option Shuffling : Yes Is

Question Mandatory : No

Correct Marks : 4 Wrong Marks : 1

The position, velocity and acceleration of a particle moving with a constant acceleration can be represented by :

Options :

86435119997.

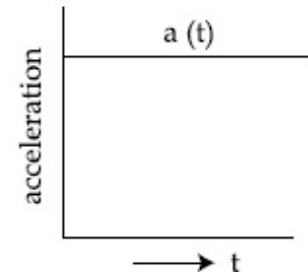
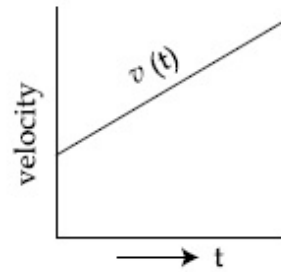
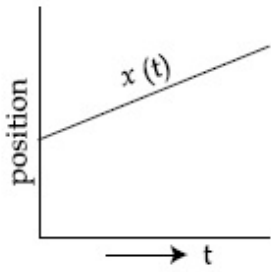

86435119998.

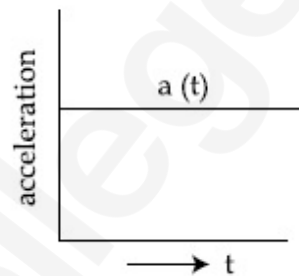
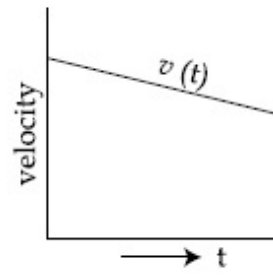
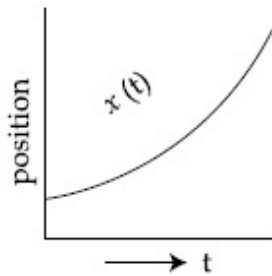

86435119999.

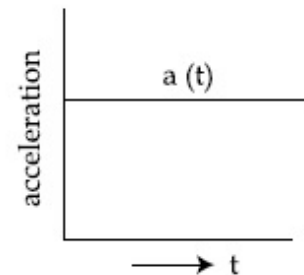
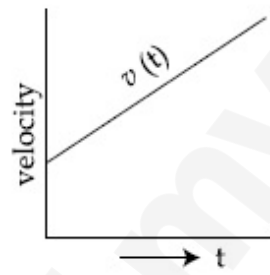
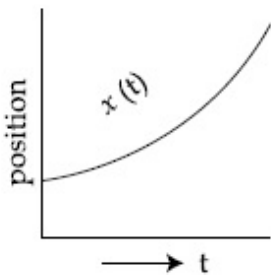

86435120000.

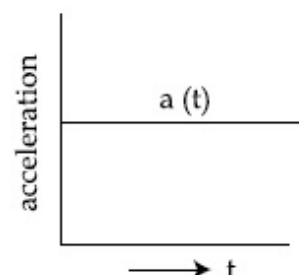
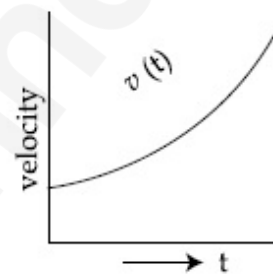
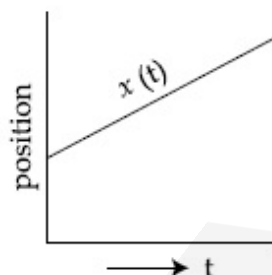

Question Number : 5 Question Id : 8643516665 Question Type : MCQ Option Shuffling : Yes Is Question Mandatory : No

Correct Marks : 4 Wrong Marks : 1

ସ୍ଥିର ତ୍ୱରଣ ସହ ଗତିଶୀଳ ଏକ କଣିକାର ଅବସ୍ଥିତି, ପରିବେଗ ଏବଂ ତ୍ୱରଣକୁ ଦର୍ଶାଯାଇପାରିବ :

Options :

86435119997.

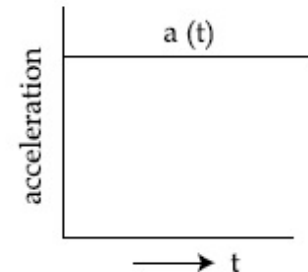
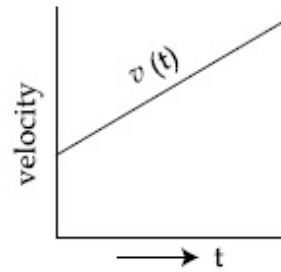
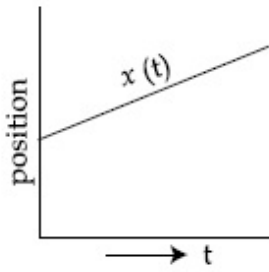

86435119998.

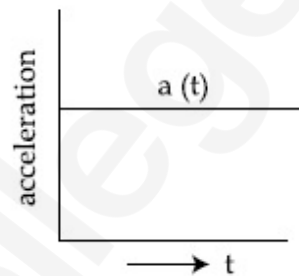
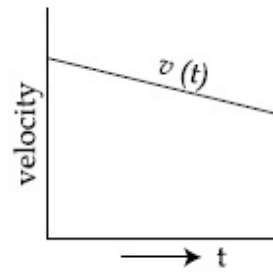
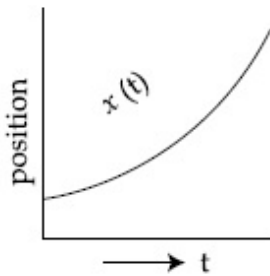

86435119999.

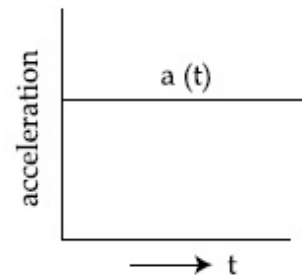
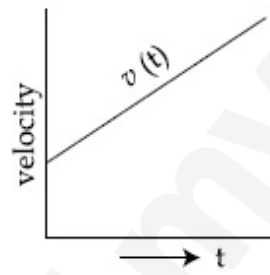
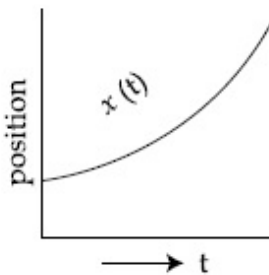

86435120000.

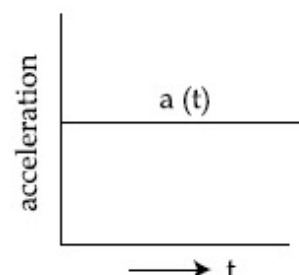
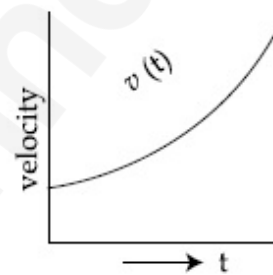
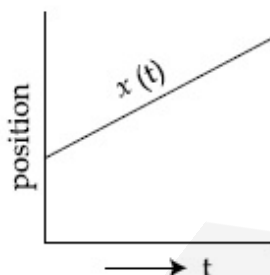

Question Number : 6 Question Id : 8643516666 Question Type : MCQ Option Shuffling : Yes Is Question Mandatory : No

Correct Marks : 4 Wrong Marks : 1

An AC source rated 220 V, 50 Hz is connected to a resistor. The time taken by the current to change from its maximum to the rms value is :

Options :

86435120001. 2.5 ms

86435120002. 25 ms

86435120003. 0.25 ms

86435120004. 2.5 s

Question Number : 6 Question Id : 8643516666 Question Type : MCQ Option Shuffling : Yes Is**Question Mandatory : No****Correct Marks : 4 Wrong Marks : 1**

220 V, 50 Hz ଆକାରରେ ମୂଲ୍ୟାଙ୍କନ ହୋଇଥିବା ଗୋଟିଏ ପ୍ରତ୍ୟାବର୍ତ୍ତୀ ବିଦ୍ୟୁତ୍ ସ୍ରୋତ (ଏ.ସି.) ର ଉତ୍ସକୁ ଏକ ବିଦ୍ୟୁତ୍ ପ୍ରତିରୋଧ ସହ ସଂଯୁକ୍ତ କରାଗଲା । ବିଦ୍ୟୁତ୍ ସ୍ରୋତର ସର୍ବାଧିକ ମୂଲ୍ୟରୁ ମାଧ୍ୟବର୍ଗର ବର୍ଗମୂଳ (ଆର.ଏମ୍.ଏସ୍) ମୂଲ୍ୟକୁ ପରିବର୍ତ୍ତନ ପାଇଁ ନେଉଥିବା ସମୟ ଅଟେ :

Options :

86435120001. 2.5 ms

86435120002. 25 ms

86435120003. 0.25 ms

86435120004. 2.5 s

Question Number : 7 Question Id : 8643516667 Question Type : MCQ Option Shuffling : Yes Is**Question Mandatory : No****Correct Marks : 4 Wrong Marks : 1**

In Young's double slit arrangement, slits are separated by a gap of 0.5 mm, and the screen is placed at a distance of 0.5 m from them. The distance between the first and the third bright fringe formed when the slits are illuminated by a monochromatic light of 5890 Å is :

Options :86435120005. 1178×10^{-12} m86435120006. 5890×10^{-7} m86435120007. 1178×10^{-9} m86435120008. 1178×10^{-6} m

Question Number : 7 Question Id : 8643516667 Question Type : MCQ Option Shuffling : Yes Is

Question Mandatory : No

Correct Marks : 4 Wrong Marks : 1

ଗୋଟିଏ ଯଜ୍ଞଙ୍କ ଦ୍ଵି-ଛଦ୍ର ବିନ୍ୟାସରେ, ଛଦ୍ର (ସ୍ଵିଚ) ଗୁଡ଼ିକ 0.5 nm ବ୍ୟବଧାନରେ ରଖାଯାଇଛି ଏବଂ ପରଦା(ସ୍କ୍ରିନ୍) ତି ସେମାନଙ୍କ ଠାରୁ 0.5 m ଦୂରତାରେ ଅଛି । ଯେତେବେଳେ ଛଦ୍ରଗୁଡ଼ିକ 5890 \AA ବିଶିଷ୍ଟ ଗୋଟିଏ ଏକବର୍ଣ୍ଣୀ ଆଲୋକ ଦ୍ଵାରା ଆଲୋକିତ କରାଯାଏ, ପ୍ରଥମ ଏବଂ ତୃତୀୟ ଉଜ୍ଜଳ ପ୍ରିଞ୍ଚ ମଧ୍ୟରେ ବ୍ୟବଧାନ ହେବ :

Options :

86435120005. $1178 \times 10^{-12} \text{ m}$

86435120006. $5890 \times 10^{-7} \text{ m}$

86435120007. $1178 \times 10^{-9} \text{ m}$

86435120008. $1178 \times 10^{-6} \text{ m}$

Question Number : 8 Question Id : 8643516668 Question Type : MCQ Option Shuffling : Yes Is

Question Mandatory : No

Correct Marks : 4 Wrong Marks : 1

A particle is travelling 4 times as fast as an electron. Assuming the ratio of de-Broglie wavelength of a particle to that of electron is 2 : 1, the mass of the particle is :

Options :

86435120009. 8 times the mass of e^{-}

86435120010. $\frac{1}{16}$ times the mass of e^{-}

86435120011. 16 times the mass of e^{-}

86435120012. $\frac{1}{8}$ times the mass of e^{-}

Question Number : 8 Question Id : 8643516668 Question Type : MCQ Option Shuffling : Yes Is

Question Mandatory : No

Correct Marks : 4 Wrong Marks : 1

ଇଲେକ୍ଟ୍ରନ୍ ଗତି କରୁଥିବା ଦେଗର 4 ଗୁଣ ଦେଗରେ କଣିକାଟିଏ ଗତି କରୁଅଛି । କଣିକାଟିର ଏବଂ ଇଲେକ୍ଟ୍ରନ୍ର ଡି-ଡ୍ରୋଗଲି ତରଙ୍ଗ ଦୈର୍ଘ୍ୟର ଅନୁପାତ 2 : 1 ବୋଲି ଗ୍ରହଣ କରିଲେ, କଣିକାଟିର ବସ୍ତୁତ୍ୱ ହେଉଛି :

Options :

86435120009. e^- ବସ୍ତୁତ୍ୱର 8 ଗୁଣ

86435120010. e^- ବସ୍ତୁତ୍ୱର $\frac{1}{16}$ ଗୁଣ

86435120011. e^- ବସ୍ତୁତ୍ୱର 16 ଗୁଣ

86435120012. e^- ବସ୍ତୁତ୍ୱର $\frac{1}{8}$ ଗୁଣ

Question Number : 9 Question Id : 8643516669 Question Type : MCQ Option Shuffling : Yes Is Question Mandatory : No

Correct Marks : 4 Wrong Marks : 1

The time period of a simple pendulum is given by $T = 2\pi\sqrt{\frac{l}{g}}$. The measured value of the length of pendulum is 10 cm known to a 1 mm accuracy. The time for 200 oscillations of the pendulum is found to be 100 second using a clock of 1 s resolution. The percentage accuracy in the determination of 'g' using this pendulum is 'x'. The value of 'x' to the nearest integer is,

Options :

86435120013. 2%

86435120014. 3%

86435120015. 4%

86435120016. 5%

Question Number : 9 Question Id : 8643516669 Question Type : MCQ Option Shuffling : Yes Is Question Mandatory : No

Correct Marks : 4 Wrong Marks : 1

ଗୋଟିଏ ସରଳ ପେଣ୍ଡୁଲମ୍‌ର ଆବର୍ତ୍ତକାଳକୁ $T = 2\pi\sqrt{\frac{l}{g}}$ ଆକାରରେ ଦର୍ଶାଯାଇଛି । ପେଣ୍ଡୁଲମ୍‌ଟିର ଦୈର୍ଘ୍ୟ 1 mm ର ସଠିକତା ସହ 10 cm ଅଟେ ଏବଂ କ୍ଷୁଦ୍ରତମ ମାପ ବ୍ୟବଧାନ 1 ସେକେଣ୍ଡ ଥିବା ଗୋଟିଏ ଘଡ଼ି ବ୍ୟବହାର କରି ଏହାର 200 ଦୋଳନର ସମୟ 100 ସେକେଣ୍ଡ ବୋଲି କଳନା କରାଗଲା । ଏହି ପେଣ୍ଡୁଲମ୍ ବ୍ୟବହାର କରି ନିର୍ଣ୍ଣୟ କରାଯାଇଥିବା 'g' ମୂଲ୍ୟରେ ରହିଥିବା ଶତକଡ଼ା ସଠିକତା 'x' ଅଟେ ।

ନିକଟତମ ପୂର୍ଣ୍ଣସଂଖ୍ୟାରେ 'x' ର ମୂଲ୍ୟ ଅଟେ :

Options :

86435120013. 2%

86435120014. 3%

86435120015. 4%

86435120016. 5%

Question Number : 10 Question Id : 8643516670 Question Type : MCQ Option Shuffling : Yes Is Question Mandatory : No

Correct Marks : 4 Wrong Marks : 1

Imagine that the electron in a hydrogen atom is replaced by a muon (μ). The mass of muon particle is 207 times that of an electron and charge is equal to the charge of an electron. The ionization potential of this hydrogen atom will be :

Options :

86435120017. 13.6 eV

86435120018. 27.2 eV

86435120019. 331.2 eV

86435120020. 2815.2 eV

Question Number : 10 Question Id : 8643516670 Question Type : MCQ Option Shuffling : Yes Is Question Mandatory : No

Correct Marks : 4 Wrong Marks : 1

କଳ୍ପନା କର ଯେ ଗୋଟିଏ ହାଇଡ୍ରୋଜେନ୍ ପରମାଣୁରେ ଥିବା ଇଲେକ୍ଟ୍ରନ୍‌ଟିକୁ ମ୍ୟୁଅନ୍ (μ) ଦ୍ଵାରା ସ୍ଥାନାନ୍ତର କରାଗଲା । ମ୍ୟୁଅନ୍ କଣିକାର ବସ୍ତୁତ୍ଵ ଇଲେକ୍ଟ୍ରନ୍ ବସ୍ତୁତ୍ଵର 207 ଗୁଣ ଏବଂ ଏହାର ଚାର୍ଜ ଇଲେକ୍ଟ୍ରନ୍ ସହ ସମାନ । ଏହି ହାଇଡ୍ରୋଜେନ୍ ପରମାଣୁର ଆୟନୀକରଣ ବିଭବ (ଆୟୋନାଇଜେସନ୍ ପୋଟେନ୍ସିଆଲ) ହେବ :

Options :

86435120017. 13.6 eV

86435120018. 27.2 eV

86435120019. 331.2 eV

86435120020. 2815.2 eV

Question Number : 11 Question Id : 8643516671 Question Type : MCQ Option Shuffling : Yes Is Question Mandatory : No

Correct Marks : 4 Wrong Marks : 1

A radioactive sample disintegrates via two independent decay processes having half lives $T_{1/2}^{(1)}$ and $T_{1/2}^{(2)}$ respectively. The effective half-life, $T_{1/2}$ of the nuclei is :

Options :

86435120021.
$$T_{1/2} = \frac{T_{1/2}^{(1)} T_{1/2}^{(2)}}{T_{1/2}^{(1)} + T_{1/2}^{(2)}}$$

86435120022.
$$T_{1/2} = T_{1/2}^{(1)} + T_{1/2}^{(2)}$$

86435120023.
$$T_{1/2} = \frac{T_{1/2}^{(1)} + T_{1/2}^{(2)}}{T_{1/2}^{(1)} - T_{1/2}^{(2)}}$$

86435120024. None of the above

Question Number : 11 Question Id : 8643516671 Question Type : MCQ Option Shuffling : Yes Is Question Mandatory : No

Correct Marks : 4 Wrong Marks : 1

ଗୋଟିଏ ତେଜସ୍ବିୟ ପଦାର୍ଥର ନମୁନା ଯଥାକ୍ରମେ ଅର୍ଦ୍ଧ ଆୟତ୍ କାଳ $T_{1/2}^{(1)}$ ଏବଂ $T_{1/2}^{(2)}$ ଥିବା ଦୁଇଟି ସ୍ୱତନ୍ତ୍ର କ୍ଷୟ ପ୍ରକ୍ରିୟାରେ ବିଘଟିତ ହେଉଛି । ନ୍ୟୁକ୍ଲିୟସ୍ ଗୁଡ଼ିକର ପକ୍ଷପୂର୍ଣ୍ଣ (ଏପେକ୍ସିଭ) ଅର୍ଦ୍ଧଆୟତ୍ $T_{1/2}$ ହେଉଛି :

Options :

$$T_{1/2} = \frac{T_{1/2}^{(1)} T_{1/2}^{(2)}}{T_{1/2}^{(1)} + T_{1/2}^{(2)}}$$

86435120021.

$$T_{1/2} = T_{1/2}^{(1)} + T_{1/2}^{(2)}$$

86435120022.

$$T_{1/2} = \frac{T_{1/2}^{(1)} + T_{1/2}^{(2)}}{T_{1/2}^{(1)} - T_{1/2}^{(2)}}$$

86435120023.

86435120024. ଏଗୁଡ଼ିକ ମଧ୍ୟରୁ କେଉଁଟି ନୁହେଁ

Question Number : 12 Question Id : 8643516672 Question Type : MCQ Option Shuffling : Yes Is Question Mandatory : No

Correct Marks : 4 Wrong Marks : 1

A loop of flexible wire of irregular shape carrying current is placed in an external magnetic field. Identify the effect of the field on the wire.

Options :

86435120025. shape of the loop remains unchanged

86435120026. loop assumes circular shape with its plane normal to the field

86435120027. loop assumes circular shape with its plane parallel to the field

86435120028. wire gets stretched to become straight

Question Number : 12 Question Id : 8643516672 Question Type : MCQ Option Shuffling : Yes Is Question Mandatory : No

Correct Marks : 4 Wrong Marks : 1

ବିଦ୍ୟୁତ୍ ସ୍ରୋତ ପ୍ରବାହିତ ହେଉଥିବା ଅସମାନ ଆକାରର ଗୋଟିଏ ନମନାୟ ତାରର ଲୁପ୍ଟକୁ ଏକ ବାହ୍ୟ ତୁମ୍ଭକାୟ କ୍ଷେତ୍ରରେ ରଖାଗଲା । ତାରଟି ଉପରେ କ୍ଷେତ୍ରର ପ୍ରଭାବକୁ ଚିହ୍ନଟାଅ :

Options :

86435120025. ଲୁପ୍ଟର ଆକାର ଅପରିବର୍ତ୍ତିତ ରହିବ ।
86435120026. ଲୁପ୍ଟର ସମତଳ କ୍ଷେତ୍ରକୁ ଲମ୍ବ ଭାବରେ ରହି ବୃତ୍ତାକାର ଆକାର ହୋଇଯିବ ।
86435120027. ଲୁପ୍ଟର ସମତଳ କ୍ଷେତ୍ରକୁ ସମାନ୍ତର ଭାବରେ ରହି ବୃତ୍ତାକାର ଆକାର ହୋଇଯିବ ।
86435120028. ତାରଟି ଭିଡ଼ି ହୋଇ ସିଧା ହୋଇଯିବ ।

Question Number : 13 Question Id : 8643516673 Question Type : MCQ Option Shuffling : Yes Is Question Mandatory : No

Correct Marks : 4 Wrong Marks : 1

In the experiment of Ohm's law, a potential difference of 5.0 V is applied across the end of a conductor of length 10.0 cm and diameter of 5.00 mm. The measured current in the conductor is 2.00 A. The maximum permissible percentage error in the resistivity of the conductor is :

Options :

86435120029. 3.9
86435120030. 7.5
86435120031. 8.4
86435120032. 3.0

Question Number : 13 Question Id : 8643516673 Question Type : MCQ Option Shuffling : Yes Is Question Mandatory : No

Correct Marks : 4 Wrong Marks : 1

ଓମ୍‌ଙ୍କ ପରୀକ୍ଷାରେ, 10.0 cm ଦୈର୍ଘ୍ୟ ଏବଂ 5.00 mm ବ୍ୟାସ ବିଶିଷ୍ଟ ଗୋଟିଏ ବିଦ୍ୟୁତ୍ ପରିବାହୀର ଦୁଇ ମୁଣ୍ଡ ମଧ୍ୟରେ 5.0 V ର ବିଭବ ପାର୍ଥକ୍ୟକୁ ପ୍ରୟୋଗ କରାଗଲା । ପରିବାହୀଟିରେ ପ୍ରବାହିତ ବିଦ୍ୟୁତ୍ ସ୍ରୋତର ମାପ 2.00 A ଅଟେ ।

ପରିବାହୀଟିର ପ୍ରତିରୋଧକତାରେ ସର୍ବାଧିକ ଅନୁମୋଦନୀୟ ଶତକଡ଼ା ତ୍ରୁଟି ଅଟେ :

Options :

86435120029. 3.9
86435120030. 7.5

86435120031. 8.4

86435120032. 3.0

Question Number : 14 Question Id : 8643516674 Question Type : MCQ Option Shuffling : Yes Is Question Mandatory : No Correct Marks : 4 Wrong Marks : 1

The time period of a satellite in a circular orbit of radius R is T . The period of another satellite in a circular orbit of radius $9R$ is :

Options :

86435120033. 3 T

86435120034. 9 T

86435120035. 27 T

86435120036. 12 T

Question Number : 14 Question Id : 8643516674 Question Type : MCQ Option Shuffling : Yes Is Question Mandatory : No Correct Marks : 4 Wrong Marks : 1

R ବ୍ୟାସାର୍ଦ୍ଧ ବିଶିଷ୍ଟ ଗୋଟିଏ ବୃତ୍ତାକାର କକ୍ଷରେ ଥିବା ଏକ ଉପଗ୍ରହର ଆବର୍ତ୍ତକାଳ T ଅଟେ । $9R$ ବ୍ୟାସାର୍ଦ୍ଧ ବିଶିଷ୍ଟ ଏକ ବୃତ୍ତାକାର କକ୍ଷପଥରେ ଥିବା ଅନ୍ୟ ଏକ ଉପଗ୍ରହର ଆବର୍ତ୍ତକାଳ ଅଟେ :

Options :

86435120033. 3 T

86435120034. 9 T

86435120035. 27 T

86435120036. 12 T

Question Number : 15 Question Id : 8643516675 Question Type : MCQ Option Shuffling : Yes Is Question Mandatory : No

Correct Marks : 4 Wrong Marks : 1

In a series LCR resonance circuit, if we change the resistance only, from a lower to higher value :

Options :

86435120037. The resonance frequency will increase
86435120038. The bandwidth of resonance circuit will increase
86435120039. The quality factor will increase
86435120040. The quality factor and the resonance frequency will remain constant

Question Number : 15 Question Id : 8643516675 Question Type : MCQ Option Shuffling : Yes Is Question Mandatory : No

Correct Marks : 4 Wrong Marks : 1

ଗୋଟିଏ LCR ଶ୍ରେଣୀରେ ସଂଯୁକ୍ତ ଅନୁନାଦ (ସିରିଜ୍ ରିଜୋନାନ୍ସ) ପରିପଥରେ, ଯଦି ଆମେ କେବଳ ବିଦ୍ୟୁତ୍ ପ୍ରତିରୋଧକଟିକୁ ବଦଳାଇ କମ ମୂଲ୍ୟରୁ ଅଧିକ ମୂଲ୍ୟ କରୁ, ତେବେ :

Options :

86435120037. ଅନୁନାଦ ଆବୃତ୍ତି ବଢ଼ିବ ।
86435120038. ଅନୁନାଦ ପରିପଥର ବ୍ୟାଣ୍ଡସ୍ପ୍ରସ୍ଥ ବଢ଼ିଯିବ ।
86435120039. ଫଳବତ୍ତା ସୂଚକ (କ୍ୱାଲିଟି ଫ୍ୟାକ୍ଟର) ବଢ଼ିଯିବ ।
86435120040. ଫଳବତ୍ତା ସୂଚକ ଏବଂ ଅନୁନାଦ ଆବୃତ୍ତି ଅବର୍ଧିତ ରହିବ ।

Question Number : 16 Question Id : 8643516676 Question Type : MCQ Option Shuffling : Yes Is Question Mandatory : No

Correct Marks : 4 Wrong Marks : 1

Your friend is having eye sight problem. She is not able to see clearly a distant uniform window mesh and it appears to her as non-uniform and distorted. The doctor diagnosed the problem as :

Options :

86435120041. Myopia and hypermetropia
86435120042. Presbyopia with Astigmatism

86435120043. Astigmatism

86435120044. Myopia with Astigmatism

Question Number : 16 Question Id : 8643516676 Question Type : MCQ Option Shuffling : Yes Is Question Mandatory : No

Correct Marks : 4 Wrong Marks : 1

ତୁମ ସାଙ୍ଗର ଆଖି ସମସ୍ୟା ରହିଛି । ସିଏ କେବଳ ଯେ ଏକ ଦୂରବର୍ତ୍ତୀ ସମାନ (ୟୁନିଫର୍ମ) ଝରକା ଜାଲିକୁ ପରିଷ୍କାର ଦେଖିପାରେ ନାହିଁ, ତା ସହିତ ଏହା ତାକୁ ଏକ ଅସମ ଏବଂ ବିକୃତାକରଣ ପରି ଦୃଶ୍ୟମାନ ହୋଇଥାଏ । ତାଙ୍କର ଏହି ସମସ୍ୟାକୁ ନିରୂପଣ କଲେ ଯେ,

Options :

86435120041. ସମାପ ଦୃଷ୍ଟି ଏବଂ ଦୂରଦୃଷ୍ଟି ଦୋଷ

86435120042. ବିଷମ ଦୃଷ୍ଟି (ଆକ୍ସିରମାଟିଜମ) ସହ ଚାଳଶୀଆ (ପ୍ରେସ୍‌ବାୟୋପିଆ)

86435120043. ବିଷମ ଦୃଷ୍ଟି (ଆକ୍ସିରମାଟିଜମ)

86435120044. ବିଷମ ଦୃଷ୍ଟି (ଆକ୍ସିରମାଟିଜମ) ସହ ସମାପ ଦୃଷ୍ଟି

Question Number : 17 Question Id : 8643516677 Question Type : MCQ Option Shuffling : Yes Is Question Mandatory : No

Correct Marks : 4 Wrong Marks : 1

What will be the average value of energy along one degree of freedom for an ideal gas in thermal equilibrium at a temperature T ? (k_B is Boltzmann constant)

Options :

86435120045. $k_B T$ 86435120046. $\frac{1}{2} k_B T$ 86435120047. $\frac{3}{2} k_B T$

86435120048. $\frac{2}{3} k_B T$

Question Number : 17 Question Id : 8643516677 Question Type : MCQ Option Shuffling : Yes Is Question Mandatory : No

Correct Marks : 4 Wrong Marks : 1

T ତାପମାତ୍ରାରେ ତାପୀୟ ସନ୍ତୁଳନରେ ଥିବା ଗୋଟିଏ ଆବର୍ଣ୍ଣ ଗ୍ୟାସ୍ ପାଇଁ ଏକ ସ୍ଵାତନ୍ତ୍ର୍ୟ ମାତ୍ରା (ଡିଗ୍ରୀଜ୍ ଅଫ୍ ଫ୍ରିଡମ୍) ରେ ହାରାହାରି ଶକ୍ତିର ମୂଲ୍ୟ କେତେ ହେବ ?

(ବୋଲଜ୍ମ୍ୟାନ୍ ଘିରାଙ୍କ k_B ଅଟେ)

Options :

86435120045. $k_B T$

86435120046. $\frac{1}{2} k_B T$

86435120047. $\frac{3}{2} k_B T$

86435120048. $\frac{2}{3} k_B T$

Question Number : 18 Question Id : 8643516678 Question Type : MCQ Option Shuffling : Yes Is Question Mandatory : No

Correct Marks : 4 Wrong Marks : 1

Match List - I with List - II.

List - I

- (a) 10 km height over earth's surface
- (b) 70 km height over earth's surface
- (c) 180 km height over earth's surface
- (d) 270 km height over earth's surface

List - II

- (i) Thermosphere
- (ii) Mesosphere
- (iii) Stratosphere
- (iv) Troposphere

Options :

86435120049. (a)-(iv), (b)-(iii), (c)-(ii), (d)-(i)

86435120050. (a)-(iii), (b)-(ii), (c)-(i), (d)-(iv)

86435120051. (a)-(ii), (b)-(i), (c)-(iv), (d)-(iii)

86435120052. (a)-(i), (b)-(iv), (c)-(iii), (d)-(ii)

Question Number : 18 Question Id : 8643516678 Question Type : MCQ Option Shuffling : Yes Is Question Mandatory : No

Correct Marks : 4 Wrong Marks : 1

ତାଲିକା - I ସହ ତାଲିକା - II କୁ ମିଳାଅ :

ତାଲିକା - I

- (a) ପୃଥିବୀ ପୃଷ୍ଠରୁ 10 km ଉର୍ଦ୍ଧ୍ୱରେ
- (b) ପୃଥିବୀ ପୃଷ୍ଠରୁ 70 km ଉର୍ଦ୍ଧ୍ୱରେ
- (c) ପୃଥିବୀ ପୃଷ୍ଠରୁ 180 km ଉର୍ଦ୍ଧ୍ୱରେ
- (d) ପୃଥିବୀ ପୃଷ୍ଠରୁ 270 km ଉର୍ଦ୍ଧ୍ୱରେ

ତାଲିକା - II

- (i) ଚାପମଣ୍ଡଳ (ଅର୍ମୋସ୍ଫିୟର)
- (ii) ମେଜୋ ମଣ୍ଡଳ (ମେଜୋସ୍ଫିୟର)
- (iii) ସମୋଷ୍ଠ ମଣ୍ଡଳ (ଷ୍ଟ୍ରାଟୋସ୍ଫିୟର)
- (iv) ଟ୍ରୋପୋ ମଣ୍ଡଳ (ଟ୍ରୋପୋସ୍ଫିୟର)

ନିମ୍ନରେ ଦତ୍ତ ବିକଳଗୁଡ଼ିକରୁ ଠିକ୍ ଉତ୍ତରଟି ଚୟନ କର :

Options :

86435120049. (a)-(iv), (b)-(iii), (c)-(ii), (d)-(i)

86435120050. (a)-(iii), (b)-(ii), (c)-(i), (d)-(iv)

86435120051. (a)-(ii), (b)-(i), (c)-(iv), (d)-(iii)

86435120052. (a)-(i), (b)-(iv), (c)-(iii), (d)-(ii)

Question Number : 19 Question Id : 8643516679 Question Type : MCQ Option Shuffling : Yes Is Question Mandatory : No

Correct Marks : 4 Wrong Marks : 1

A plane electromagnetic wave of frequency 100 MHz is travelling in vacuum along the x -direction. At a particular point in space and time, $\vec{B} = 2.0 \times 10^{-8} \hat{k}$ T. (where, \hat{k} is unit vector along z -direction) What is \vec{E} at this point ?

(speed of light $c = 3 \times 10^8$ m/s)

Options :

86435120053. $0.6 \hat{j}$ V/m

86435120054. $6.0 \hat{j} \text{ V/m}$

86435120055. $6.0 \hat{k} \text{ V/m}$

86435120056. $0.6 \hat{k} \text{ V/m}$

Question Number : 19 Question Id : 8643516679 Question Type : MCQ Option Shuffling : Yes Is Question Mandatory : No

Correct Marks : 4 Wrong Marks : 1

ଶୂନ୍ୟରେ x -ଦିଗରେ, 100 MHz ଆବୃତ୍ତିର ଏକ ସମତାଳୀୟ ବିଦ୍ୟୁତ୍ ଚୁମ୍ବକୀୟ ତରଙ୍ଗ ଗତି କରୁଅଛି । ଏକ ଶୂନ୍ୟର ନିର୍ଦ୍ଦିଷ୍ଟ ବିନ୍ଦୁରେ ଏବଂ ସମୟରେ, $\vec{B} = 2.0 \times 10^{-8} \hat{k} \text{ T}$ (ଯେଉଁଠାରେ, \hat{k} ହେଉଛି z -ଦିଗରେ ଥିବା ଏକକ ସଦିଶ) ।

ଏହି ବିନ୍ଦୁରେ \vec{E} ମୂଲ୍ୟ କେତେ ହେବ ?

(ଆଲୋକର ବେଗ $c = 3 \times 10^8 \text{ m/s}$)

Options :

86435120053. $0.6 \hat{j} \text{ V/m}$

86435120054. $6.0 \hat{j} \text{ V/m}$

86435120055. $6.0 \hat{k} \text{ V/m}$

86435120056. $0.6 \hat{k} \text{ V/m}$

Question Number : 20 Question Id : 8643516680 Question Type : MCQ Option Shuffling : Yes Is Question Mandatory : No

Correct Marks : 4 Wrong Marks : 1

A thin circular ring of mass M and radius r is rotating about its axis with an angular speed ω . Two particles having mass m each are now attached at diametrically opposite points. The angular speed of the ring will become :

Options :

86435120057. $\omega \frac{M}{M + m}$

86435120058. $\omega \frac{M}{M + 2m}$

86435120059. $\omega \frac{M - 2m}{M + 2m}$

86435120060. $\omega \frac{M + 2m}{M}$

Question Number : 20 Question Id : 8643516680 Question Type : MCQ Option Shuffling : Yes Is Question Mandatory : No Correct Marks : 4 Wrong Marks : 1

ବସ୍ତୁରୁ M ଏବଂ ବ୍ୟାସାର୍ଦ୍ଧ r ବିଶିଷ୍ଟ ଏକ ପତଳା ଗୋଲାକାର ବଳୟ ଏହାର ଅକ୍ଷ ଚାରିପଟେ ω କୌଣସି ବେଗରେ ଘୂରୁଅଛି । ପ୍ରତ୍ୟେକ m ବସ୍ତୁ ବିଶିଷ୍ଟ ଦୁଇଟି କଣିକାକୁ ଏହାର ଏକ ବ୍ୟାସ ଦିଗରେ ଦୁଇଟି ବିପରୀତ ବିନ୍ଦୁରେ ଯୋଡ଼ାଗଲା । ବଳୟଟିର କୌଣସି ବେଗ ହୋଇନାହିବ :

Options :

86435120057. $\omega \frac{M}{M + m}$

86435120058. $\omega \frac{M}{M + 2m}$

86435120059. $\omega \frac{M - 2m}{M + 2m}$

86435120060. $\omega \frac{M + 2m}{M}$

Physics Section B

Section Id :	864351446
Section Number :	2
Section type :	Online
Mandatory or Optional :	Mandatory
Number of Questions :	10
Number of Questions to be attempted :	5
Section Marks :	20
Mark As Answered Required? :	Yes

Sub-Section Number : 1
Sub-Section Id : 864351446
Question Shuffling Allowed : Yes

Question Number : 21 Question Id : 8643516681 Question Type : SA
Correct Marks : 4 Wrong Marks : 0

An npn transistor operates as a common emitter amplifier with a power gain of 10^6 . The input circuit resistance is $100\ \Omega$ and the output load resistance is $10\ \text{k}\Omega$. The common emitter current gain ' β ' will be _____. (Round off to the Nearest Integer)

Response Type : Numeric
Evaluation Required For SA : Yes
Show Word Count : Yes
Answers Type : Equal
Text Areas : PlainText
Possible Answers :

100

Question Number : 21 Question Id : 8643516681 Question Type : SA
Correct Marks : 4 Wrong Marks : 0

10^6 ପାୱାର ଗେନ୍ ସହ ଗୋଟିଏ npn ଟ୍ରାଞ୍ଜିଷ୍ଟର ଏକ ସାଧାରଣ ଉତ୍ସର୍ଜକ ପ୍ରବର୍ଦ୍ଧକ ଆକାରରେ କାର୍ଯ୍ୟ କରୁଅଛି । ନିବେଶ ପରିପଥ ପ୍ରତିରୋଧ $100\ \Omega$ ଏବଂ ବର୍ତ୍ତବେଶ ଲୋଡ଼ ପ୍ରତିରୋଧ $10\ \text{k}\Omega$ ଅଟେ ।

ସାଧାରଣ ଉତ୍ସର୍ଜକ ଲଞ୍ଜ ବିଦ୍ୟୁତ୍ ସ୍ରୋତ ' β ' ହେବ _____ । (ନିକଟତମ ପୂର୍ଣ୍ଣସଂଖ୍ୟାରେ ପରିଣତ କର)

Response Type : Numeric
Evaluation Required For SA : Yes
Show Word Count : Yes
Answers Type : Equal
Text Areas : PlainText
Possible Answers :

100

Question Number : 22 Question Id : 8643516682 Question Type : SA
Correct Marks : 4 Wrong Marks : 0

A ball of mass 10 kg moving with a velocity $10\sqrt{3}$ m/s along the x -axis, hits another ball of mass 20 kg which is at rest. After the collision, first ball comes to rest while the second ball disintegrates into two equal pieces. One piece starts moving along y -axis with a speed of 10 m/s. The second piece starts moving at an angle of 30° with respect to the x -axis.

The velocity of the ball moving at 30° with x -axis is x m/s.

The configuration of pieces after collision is shown in the figure below.

The value of x to the nearest integer is _____.

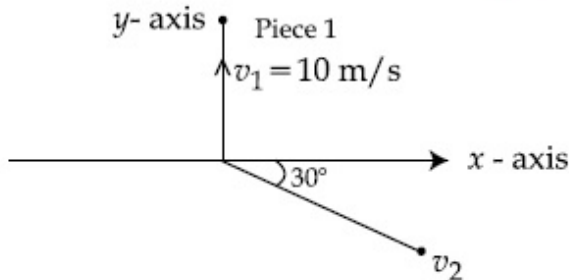

Response Type : Numeric

Evaluation Required For SA : Yes

Show Word Count : Yes

Answers Type : Equal

Text Areas : PlainText

Possible Answers :

100

Question Number : 22 **Question Id :** 8643516682 **Question Type :** SA

Correct Marks : 4 **Wrong Marks :** 0

x -ଅକ୍ଷ ଦିଗରେ $10\sqrt{3}$ m/s ପରିବେଶରେ ଗତିକରୁଥିବା 10 kg ବସ୍ତୁର ବିଶିଷ୍ଟ ଗୋଟିଏ ବଲ୍, ଛିର ଅବସ୍ଥାରେ ଥିବା 20 kg ବସ୍ତୁର ବିଶିଷ୍ଟ ଅନ୍ୟ ଏକ ବଲ୍‌କୁ ଧକ୍କା ଦେଉଛି । ଧକ୍କା ପରେ, ପ୍ରଥମ ବଲ୍‌ଟି ଛିର ଅବସ୍ଥାକୁ ଆସିଗଲା ଯେତେବେଳେ ଦ୍ୱିତୀୟ ବଲ୍‌ଟି ଦୁଇ ସମାନ ଖଣ୍ଡରେ ଭାଙ୍ଗିଗଲା । ଗୋଟିଏ ଖଣ୍ଡ y -ଅକ୍ଷ ଦିଗରେ 10 m/s ବେଗରେ ଗତି କରିବା ଆରମ୍ଭ କଲା । ଦ୍ୱିତୀୟ ଖଣ୍ଡଟି x -ଅକ୍ଷକୁ 30° କୋଣରେ ଗତି କରିବା ଆରମ୍ଭ କଲା । x -ଅକ୍ଷକୁ 30° କୋଣ କରି ଯାଉଥିବା ଖଣ୍ଡଟିର ବେଗ x m/s ଅଟେ । ଧକ୍କା ପରେ ଖଣ୍ଡଗୁଡ଼ିକର ବିନ୍ୟାସକୁ ନିମ୍ନ ଚିତ୍ରରେ ଦର୍ଶାଯାଇଛି । x ର ମୂଲ୍ୟ ଅଟେ _____ ।

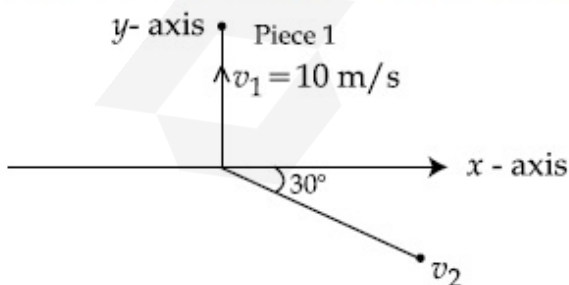

Response Type : Numeric

Evaluation Required For SA : Yes

Show Word Count : Yes

Answers Type : Equal

Text Areas : PlainText

Possible Answers :

100

Question Number : 23 Question Id : 8643516683 Question Type : SA

Correct Marks : 4 Wrong Marks : 0

The voltage across the $10\ \Omega$ resistor in the given circuit is x volt.

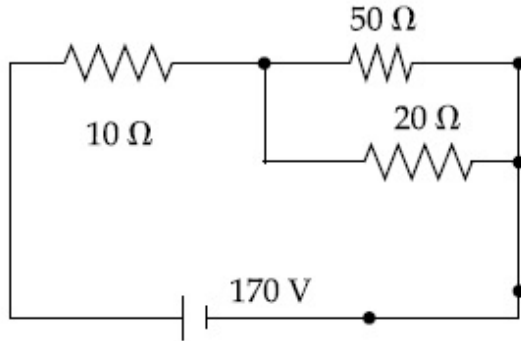

The value of ' x ' to the nearest integer is _____.

Response Type : Numeric

Evaluation Required For SA : Yes

Show Word Count : Yes

Answers Type : Equal

Text Areas : PlainText

Possible Answers :

100

Question Number : 23 Question Id : 8643516683 Question Type : SA

Correct Marks : 4 Wrong Marks : 0

ଦତ୍ତ ବିଦ୍ୟୁତ୍ ପରିପଥରେ $10\ \Omega$ ପ୍ରତିରୋଧର ଦୁଇମୁଣ୍ଡ ମଧ୍ୟରେ ଥିବା ବିଦ୍ୟୁତ୍ ବିଭବାନ୍ତର x ଭୋଲଟ୍ ।

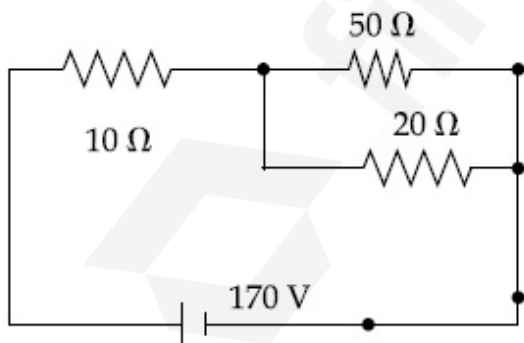

' x ' ର ମୂଲ୍ୟ ହେବ _____ ।

Response Type : Numeric

Evaluation Required For SA : Yes

Show Word Count : Yes

Answers Type : Equal

Text Areas : PlainText

Possible Answers :

100

Question Number : 24 Question Id : 8643516684 Question Type : SA

Correct Marks : 4 Wrong Marks : 0

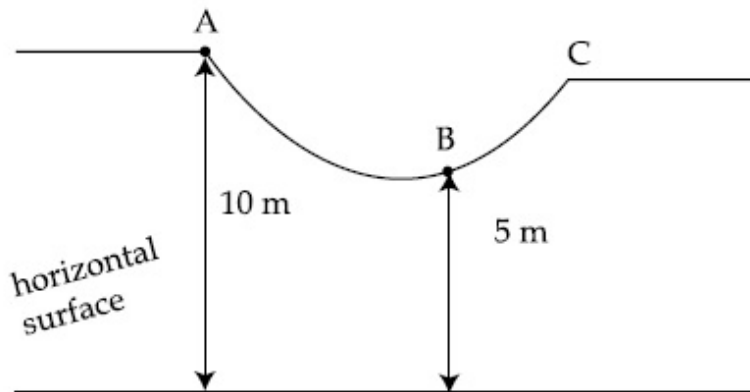

As shown in the figure, a particle of mass 10 kg is placed at a point A. When the particle is slightly displaced to its right, it starts moving and reaches the point B. The speed of the particle at B is x m/s.

(Take $g = 10 \text{ m/s}^2$)

The value of ' x ' to the nearest integer is _____.

Response Type : Numeric

Evaluation Required For SA : Yes

Show Word Count : Yes

Answers Type : Equal

Text Areas : PlainText

Possible Answers :

100

Question Number : 24 Question Id : 8643516684 Question Type : SA

Correct Marks : 4 Wrong Marks : 0

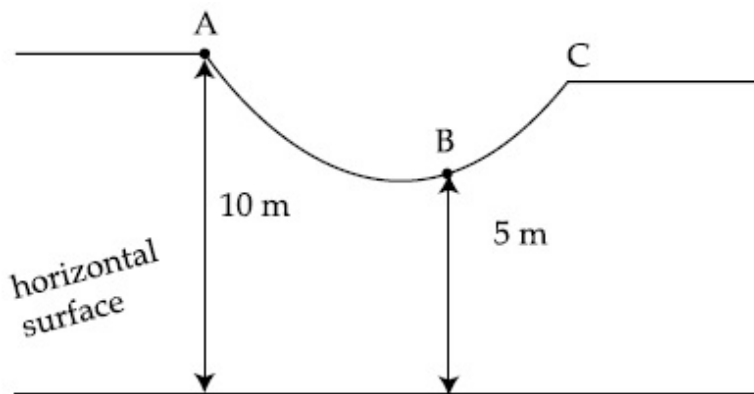

ଦର୍ଶାଯାଇଥିବା ଚିତ୍ର ଅନୁସାରେ, 10 kg ବସ୍ତୁର ବିଶିଷ୍ଟ ଗୋଟିଏ କଣିକାଟିଏ A ବିନ୍ଦୁରେ ରଖାଯାଇଛି । ଯେତେବେଳେ କଣିକାଟିକୁ ଏହାର ତାହାଣକୁ ସାମାନ୍ୟ ଘୁଞ୍ଚାଯାଏ, ଏହା ଗତିକରିବା ଆରମ୍ଭ କରେ ଏବଂ B ବିନ୍ଦୁରେ ପହଞ୍ଚେ । B ବିନ୍ଦୁରେ କଣିକାଟିର ବେଗ x m/s ଅଟେ ।

(ନିଅ $g = 10 \text{ m/s}^2$)

'x' ର ମୂଲ୍ୟ ହେଉଛି _____ ।

Response Type : Numeric

Evaluation Required For SA : Yes

Show Word Count : Yes

Answers Type : Equal

Text Areas : PlainText

Possible Answers :

100

Question Number : 25 **Question Id :** 8643516685 **Question Type :** SA

Correct Marks : 4 **Wrong Marks :** 0

A particle performs simple harmonic motion with a period of 2 second. The time taken by the particle to cover a displacement equal to half of its amplitude from the mean position is $\frac{1}{a}$ s.

The value of 'a' to the nearest integer is _____.

Response Type : Numeric

Evaluation Required For SA : Yes

Show Word Count : Yes

Answers Type : Equal

Text Areas : PlainText

Possible Answers :

100

Question Number : 25 **Question Id :** 8643516685 **Question Type :** SA

Correct Marks : 4 **Wrong Marks :** 0

2 ସେକେଣ୍ଡ ଆବର୍ତ୍ତକାଳ ସହ ଗୋଟିଏ କଣିକା ସରଳ ହାରମୋନିକ ଗତିରେ ସମ୍ପାଦିତ କରୁଅଛି । ମଧ୍ୟବର୍ତ୍ତୀ ସ୍ଥାନ (ମିନ୍ ଯୋଜିସନ୍) ରୁ ଆୟାମର ଅଧା ଦୂରତାକୁ ବିସ୍ଥାପନ ପାଇଁ କଣିକାଟି ନେଉଥିବା ସମୟ $\frac{1}{a}$ s ଅଟେ ।

'a' ର ମୂଲ୍ୟ ଅଟେ _____ ।

Response Type : Numeric

Evaluation Required For SA : Yes

Show Word Count : Yes

Answers Type : Equal

Text Areas : PlainText

Possible Answers :

100

Question Number : 26 **Question Id :** 8643516686 **Question Type :** SA

Correct Marks : 4 **Wrong Marks :** 0

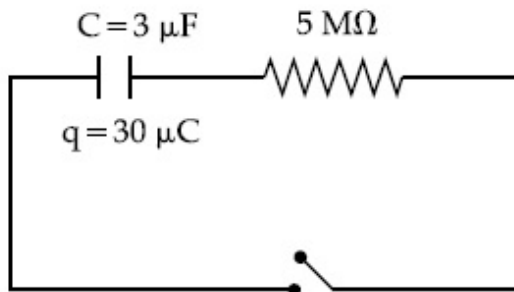

The circuit shown in the figure consists of a charged capacitor of capacity $3 \mu\text{F}$ and a charge of $30 \mu\text{C}$. At time $t=0$, when the key is closed, the value of current flowing through the $5 \text{ M}\Omega$ resistor is ' x ' μA .

The value of ' x ' to the nearest integer is _____.

Response Type : Numeric

Evaluation Required For SA : Yes

Show Word Count : Yes

Answers Type : Equal

Text Areas : PlainText

Possible Answers :

100

Question Number : 26 **Question Id :** 8643516686 **Question Type :** SA

Correct Marks : 4 **Wrong Marks :** 0

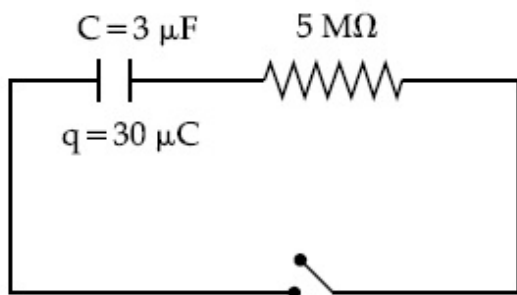

ଚିତ୍ରରେ ଦର୍ଶାଯାଇଥିବା ବୈଦ୍ୟୁତିକ ପରିପଥଟିରେ $3 \mu\text{F}$ ଧାରିତା ଏବଂ $30 \mu\text{C}$ ଚାର୍ଜ ସହ ଏକ ଧାରିତ୍ର ରହିଅଛି । $t=0$ ସମୟରେ, ଯେତେବେଳେ 'କି' କୁ ବନ୍ଦ କରିଦିଆଯାଏ, $5 \text{ M}\Omega$ ପ୍ରତିରୋଧକ ଦେଇ ପ୍ରବାହିତ ବିଦ୍ୟୁତ୍ ସ୍ରୋତର ପରିମାଣ 'x' μA ।

'x' ର ମୂଲ୍ୟ ଅଟେ _____ ।

Response Type : Numeric

Evaluation Required For SA : Yes

Show Word Count : Yes

Answers Type : Equal

Text Areas : PlainText

Possible Answers :

100

Question Number : 27 **Question Id :** 8643516687 **Question Type :** SA

Correct Marks : 4 **Wrong Marks :** 0

A person is swimming with a speed of 10 m/s at an angle of 120° with the flow and reaches to a point directly opposite on the other side of the river. The speed of the flow is 'x' m/s .

The value of 'x' to the nearest integer is _____.

Response Type : Numeric

Evaluation Required For SA : Yes

Show Word Count : Yes

Answers Type : Equal

Text Areas : PlainText

Possible Answers :

100

Question Number : 27 **Question Id :** 8643516687 **Question Type :** SA

Correct Marks : 4 **Wrong Marks :** 0

ଜଣେ ବ୍ୟକ୍ତି ଜଳ ସ୍ରୋତ ସହ 120° କୋଣ କରି 10 m/s ବେଗରେ ପହଞ୍ଚୁଛି ଏବଂ ନଦୀର ଠିକ୍ ବିପରୀତ ବିନ୍ଦୁରେ ପହଞ୍ଚୁଛି । ସ୍ରୋତର ବେଗ ଅଟେ 'x' m/s । 'x' ର ମୂଲ୍ୟ ହେବ _____ ।

Response Type : Numeric

Evaluation Required For SA : Yes

Show Word Count : Yes

Answers Type : Equal

Text Areas : PlainText

Possible Answers :

100

Question Number : 28 Question Id : 8643516688 Question Type : SA**Correct Marks : 4 Wrong Marks : 0**

Two separate wires A and B are stretched by 2 mm and 4 mm respectively, when they are subjected to a force of 2 N. Assume that both the wires are made up of same material and the radius of wire B is 4 times that of the radius of wire A. The length of the wires A and B

are in the ratio of a : b. Then $\frac{a}{b}$ can be expressed as $\frac{1}{x}$ where x is _____.

Response Type : Numeric**Evaluation Required For SA : Yes****Show Word Count : Yes****Answers Type : Equal****Text Areas : PlainText****Possible Answers :**

100

Question Number : 28 Question Id : 8643516688 Question Type : SA**Correct Marks : 4 Wrong Marks : 0**

ଯେତେବେଳେ ଦୁଇଟି ଅଲଗା ତାର A ଓ B ଉପରେ 2 N ପରିମାଣର ଏକ ବଳ ପ୍ରୟୋଗ କରାଯାଏ, ସେମାନେ ଯଥାକ୍ରମେ 2 mm ଏବଂ 4 mm ପରିମାଣର ସଂପ୍ରସାରିତ ହୋଇଥାନ୍ତି । ଧର ଦୁଇଟିଯାକ ତାରର ଏକ ପଦାର୍ଥରେ ତିଆରି ଏବଂ B ତାରର

ବ୍ୟାସାର୍ଦ୍ଧ A ତାରର ବ୍ୟାସାର୍ଦ୍ଧର 4 ଗୁଣ । A ଓ B ତାରର ଦୈର୍ଘ୍ୟର ଅନୁପାତ a : b ଅଟେ । ତାହାକୁ $\frac{a}{b}$ କୁ $\frac{1}{x}$ ହିସାବରେ

ପ୍ରକାଶ କରି ହେବ ଯେଉଁଠି x _____ ଅଟେ ।

Response Type : Numeric**Evaluation Required For SA : Yes****Show Word Count : Yes****Answers Type : Equal****Text Areas : PlainText****Possible Answers :**

100

Question Number : 29 Question Id : 8643516689 Question Type : SA**Correct Marks : 4 Wrong Marks : 0**

A parallel plate capacitor has plate area 100 m^2 and plate separation of 10 m . The space between the plates is filled up to a thickness 5 m with a material of dielectric constant of 10 . The resultant capacitance of the system is ' x ' pF.

The value of $\epsilon_0 = 8.85 \times 10^{-12} \text{ F.m}^{-1}$

The value of ' x ' to the nearest integer is _____.

Response Type : Numeric

Evaluation Required For SA : Yes

Show Word Count : Yes

Answers Type : Equal

Text Areas : PlainText

Possible Answers :

100

Question Number : 29 **Question Id :** 8643516689 **Question Type :** SA

Correct Marks : 4 **Wrong Marks :** 0

ଗୋଟିଏ ସମାନ୍ତର ପ୍ଲେଟ୍ ଧାରିତ୍ରର ପ୍ଲେଟ୍ କ୍ଷେତ୍ରଫଳ 100 m^2 ଏବଂ ପ୍ଲେଟ୍ ମଧ୍ୟରେ ଦୂରତା 10 m ଅଟେ । ପରାବୈଦ୍ୟୁତିକାଙ୍କ 10 ଥିବା 5 m ମୋଟାର ଏକ ପଦାର୍ଥ ଦ୍ୱାରା ପ୍ଲେଟ୍‌ଦୁଇଟି ମଧ୍ୟରେ ରଖାଗଲା । ଏହି ବ୍ୟବସ୍ଥାଟିର ପରିଣାମୀ ଧାରିତା ଅଟେ ' x ' pF. ।

($\epsilon_0 = 8.85 \times 10^{-12} \text{ F.m}^{-1}$)

ନିକଟତମ ପୂର୍ଣ୍ଣସଂଖ୍ୟାରେ ' x ' ର ମୂଲ୍ୟ ହେବ _____ ।

Response Type : Numeric

Evaluation Required For SA : Yes

Show Word Count : Yes

Answers Type : Equal

Text Areas : PlainText

Possible Answers :

100

Question Number : 30 **Question Id :** 8643516690 **Question Type :** SA

Correct Marks : 4 **Wrong Marks :** 0

A bullet of mass 0.1 kg is fired on a wooden block to pierce through it, but it stops after moving a distance of 50 cm into it. If the velocity of bullet before hitting the wood is 10 m/s and it slows down with uniform deceleration, then the magnitude of effective retarding force on the bullet is ' x ' N.

The value of ' x ' to the nearest integer is _____.

Response Type : Numeric

Evaluation Required For SA : Yes

Show Word Count : Yes

Answers Type : Equal

Text Areas : PlainText

Possible Answers :

100

Question Number : 30 Question Id : 8643516690 Question Type : SA**Correct Marks : 4 Wrong Marks : 0**

ଗୋଟିଏ କାଠ ବ୍ଲକ୍କୁ ଭେଦ କରିବା ପାଇଁ 0.1 kg ବସ୍ତୁ ବିଶିଷ୍ଟ ଗୋଟିଏ ଗୁଳିକୁ ଫାୟାର କରାଗଲା, କିନ୍ତୁ ଏହା କାଠ ମଧ୍ୟରେ 50 cm ଗଲାପରେ ସ୍ଥିର ହୋଇଗଲା । ଯଦି କାଠଟିକୁ ଆଘାତ ଦେବା ପୂର୍ବରୁ ଗୁଳିଟିର ବେଗ 10 m/s ହୁଏ ଏବଂ ଏହା ସମତୁରଣରେ ଧ୍ୱାଲ ଯାଏ, ତେବେ ଗୁଳିଟି ଉପରେ ପଡୁଥିବା ପରିଣାମୀ ମିଳିତ ବଳ ହେବ 'x' N ।

'x' ର ମୂଲ୍ୟ ହେବ _____ ।

Response Type : Numeric**Evaluation Required For SA : Yes****Show Word Count : Yes****Answers Type : Equal****Text Areas : PlainText****Possible Answers :**

100

Chemistry Section A

Section Id :	864351447
Section Number :	3
Section type :	Online
Mandatory or Optional :	Mandatory
Number of Questions :	20
Number of Questions to be attempted :	20
Section Marks :	80
Mark As Answered Required? :	Yes
Sub-Section Number :	1
Sub-Section Id :	864351447
Question Shuffling Allowed :	Yes

Question Number : 31 Question Id : 8643516691 Question Type : MCQ Option Shuffling : Yes Is**Question Mandatory : No****Correct Marks : 4 Wrong Marks : 1**

In a binary compound, atoms of element A form a hcp structure and those of element M occupy 2/3 of the tetrahedral voids of the hcp structure. The formula of the binary compound is :

Options :86435120071. M_2A_3 86435120072. M_4A_3

86435120073. MA_3 86435120074. M_4A

Question Number : 31 Question Id : 8643516691 Question Type : MCQ Option Shuffling : Yes Is Question Mandatory : No

Correct Marks : 4 Wrong Marks : 1

ଏକ ଦ୍ଵିକ ଯୌଗିକରେ ମୌଳିକ A ର ପରମାଣୁଗୁଡ଼ିକ ଏକ hcp ସଂରଚନା ସୃଷ୍ଟି କରନ୍ତି ଏବଂ ମୌଳିକ M ର ପରମାଣୁଗୁଡ଼ିକ hcp ସଂରଚନାରେ ଦୁଇ ଚୂଳାୟାଂଶ ଚେତ୍ରାହେତ୍ରାଳ୍ ଶୂନ୍ୟ ସ୍ଥାନ ଅଧିକାର କରନ୍ତି । ଦ୍ଵିକ ଯୌଗିକର ସୂତ୍ର ହେଉଛି :

Options :

86435120071. M_2A_3 86435120072. M_4A_3 86435120073. MA_3 86435120074. M_4A

Question Number : 32 Question Id : 8643516692 Question Type : MCQ Option Shuffling : Yes Is Question Mandatory : No

Correct Marks : 4 Wrong Marks : 1

A certain orbital has no angular nodes and two radial nodes. The orbital is :

Options :

86435120075. $2s$ 86435120076. $2p$ 86435120077. $3s$ 86435120078. $3p$

Question Number : 32 Question Id : 8643516692 Question Type : MCQ Option Shuffling : Yes Is Question Mandatory : No

Correct Marks : 4 Wrong Marks : 1

ଏକ ନିର୍ଦ୍ଦିଷ୍ଟ ଅରବିଟାଲରେ କୌଣସି ନୋଡସ୍ ନାହିଁ ଏବଂ ଦୁଇ ରେଡିଆଲ ନୋଡସ୍ ଅଛି । ଅରବିଟାଲଟି ହେଉଛି :

Options :

86435120075. 2s

86435120076. 2p

86435120077. 3s

86435120078. 3p

Question Number : 33 Question Id : 8643516693 Question Type : MCQ Option Shuffling : Yes Is Question Mandatory : No

Correct Marks : 4 Wrong Marks : 1

Match List - I with List - II :

List - I (Process)	List - II (Catalyst)
(a) Deacon's process	(i) ZSM-5
(b) Contact process	(ii) CuCl_2
(c) Cracking of hydrocarbons	(iii) Particles 'Ni'
(d) Hydrogenation of vegetable oils	(iv) V_2O_5

Choose the most appropriate answer from the options given below :

Options :

86435120079. (a)-(i), (b)-(iii), (c)-(ii), (d)-(iv)

86435120080. (a)-(iv), (b)-(ii), (c)-(i), (d)-(iii)

86435120081. (a)-(iii), (b)-(i), (c)-(iv), (d)-(ii)

86435120082. (a)-(ii), (b)-(iv), (c)-(i), (d)-(iii)

Question Number : 33 Question Id : 8643516693 Question Type : MCQ Option Shuffling : Yes Is Question Mandatory : No

Correct Marks : 4 Wrong Marks : 1

ତାଲିକା - I ସହ ତାଲିକା - II କୁ ମିଳାଅ :

ତାଲିକା - I
(ପ୍ରଣାଳୀ)

- (a) ଡିକନକ ପ୍ରଣାଳୀ
(b) କଣ୍ଠାକୁ ପ୍ରଣାଳୀ
(c) ହାଇଡ୍ରୋକାର୍ବନ୍ ଉତ୍ତାନ
(d) ଭେଜିଟେବୁ ତେଲର ଉତ୍ତାନୀକରଣ

ତାଲିକା - II
(ଉତ୍ପ୍ରୋକ)

- (i) ZSM-5
(ii) CuCl_2
(iii) Particles 'Ni'
(iv) V_2O_5

ନିମ୍ନଲିଖିତ ବିକଳ୍ପ ମଧ୍ୟରୁ ସର୍ବାଧିକ ଉପଯୁକ୍ତ ଉତ୍ତରଟି ବାଛି :

Options :

86435120079. (a)-(i), (b)-(iii), (c)-(ii), (d)-(iv)

86435120080. (a)-(iv), (b)-(ii), (c)-(i), (d)-(iii)

86435120081. (a)-(iii), (b)-(i), (c)-(iv), (d)-(ii)

86435120082. (a)-(ii), (b)-(iv), (c)-(i), (d)-(iii)

Question Number : 34 Question Id : 8643516694 Question Type : MCQ Option Shuffling : Yes Is Question Mandatory : No

Correct Marks : 4 Wrong Marks : 1

The ionic radius of Na^+ ion is 1.02 \AA . The ionic radii (in \AA) of Mg^{2+} and Al^{3+} , respectively, are :

Options :

86435120083. 0.85 and 0.99

86435120084. 0.72 and 0.54

86435120085. 0.68 and 0.72

86435120086. 1.05 and 0.99

Question Number : 34 Question Id : 8643516694 Question Type : MCQ Option Shuffling : Yes Is Question Mandatory : No

Correct Marks : 4 Wrong Marks : 1

Na^+ ଆୟନର ଆୟନିକ ବ୍ୟାସାର୍ଦ୍ଧ ହେଉଛି 1.02 \AA । Mg^{2+} ଏବଂ Al^{3+} ର ଆୟନିକ ବ୍ୟାସାର୍ଦ୍ଧ \AA ଯଥାକ୍ରମେ ହେଉଛି :

Options :

86435120083. 0.85 ଏବଂ 0.99

86435120084. 0.72 ଏବଂ 0.54

86435120085. 0.68 ଏବଂ 0.72

86435120086. 1.05 ଏବଂ 0.99

Question Number : 35 Question Id : 8643516695 Question Type : MCQ Option Shuffling : Yes Is Question Mandatory : No

Correct Marks : 4 Wrong Marks : 1

The chemical that is added to reduce the melting point of the reaction mixture during the extraction of aluminium is :

Options :

86435120087. Bauxite

86435120088. Kaolite

86435120089. Calamine

86435120090. Cryolite

Question Number : 35 Question Id : 8643516695 Question Type : MCQ Option Shuffling : Yes Is Question Mandatory : No

Correct Marks : 4 Wrong Marks : 1

ଆଲୁମିନିୟମ୍ ନିଷ୍କାସନ ସମୟରେ ପ୍ରତିକ୍ରିୟା ମିଶ୍ରଣର ଗଣନାଙ୍କ ହ୍ରାସ ପାଇଁ ମିଶାଯାଉଥିବା ରାସାୟନିକଟି ହେଉଛି :

Options :

86435120087. ବକ୍ସାଇଟ୍

86435120088. କାଓଲାଇଟ୍

86435120089. କାଲମାଇନ

86435120090. କ୍ରାଇଲାଇଟ୍

Question Number : 36 Question Id : 8643516696 Question Type : MCQ Option Shuffling : Yes Is Question Mandatory : No

Correct Marks : 4 Wrong Marks : 1

Given below are two Statements : One is labelled as Assertion A and the other is labelled as Reason R :

Assertion A : During the boiling of water having temporary hardness, $Mg(HCO_3)_2$ is converted to $MgCO_3$.

Reason R : The solubility product of $Mg(OH)_2$ is greater than that of $MgCO_3$.

In the light of the above statements, choose the most appropriate answer from the options given below :

Options :

86435120091. Both A and R are true and R is the correct explanation of A

86435120092. Both A and R are true but R is NOT the correct explanation of A

86435120093. A is true but R is false

86435120094. A is false but R is true

Question Number : 36 Question Id : 8643516696 Question Type : MCQ Option Shuffling : Yes Is Question Mandatory : No

Correct Marks : 4 Wrong Marks : 1

ନିମ୍ନରେ ଦୁଇଟି ଉକ୍ତି ଦିଆଯାଇଛି । ଗୋଟିଏ ଦୃଢ଼ୋକ୍ତି A ଏବଂ ଅନ୍ୟଟି କାରଣ R ।

ଦୃଢ଼ୋକ୍ତି A : ଅସ୍ଥାୟୀ ଖରଚୁ ଥିବା କଠିନ ଜଳ ଫୁଟିବା ସମୟରେ $Mg(HCO_3)_2$ ଟି $MgCO_3$ ରେ ପରିଣତ ହୋଇଯାଏ ।

କାରଣ R : $Mg(OH)_2$ ର ଦ୍ରବଣୀୟତା ଗୁଣଫଳ $MgCO_3$ ର ଦ୍ରବଣୀୟତା ଗୁଣଫଳ ଠାରୁ ଅଧିକ ।

ଉପରୋକ୍ତ ଉକ୍ତି ଅନୁସାରେ ନିମ୍ନଲିଖିତ ବିକଳ୍ପ ମଧ୍ୟରୁ ସର୍ବାଧିକ ଉପଯୁକ୍ତ ଉତ୍ତରଟି ବାଛି :

Options :

86435120091. ଉଭୟ A ଏବଂ R ସତ୍ୟ ଏବଂ A ର ସଠିକ୍ ବ୍ୟାଖ୍ୟା ହେଉଛି R ।

86435120092. ଉଭୟ A ଏବଂ R ସତ୍ୟ କିନ୍ତୁ A ର ସଠିକ୍ ବ୍ୟାଖ୍ୟା ନୁହେଁ R ।

86435120093. A ସତ୍ୟ କିନ୍ତୁ R ମିଥ୍ୟା ।

86435120094. A ମିଥ୍ୟା କିନ୍ତୁ R ସତ୍ୟ ।

Question Number : 37 Question Id : 8643516697 Question Type : MCQ Option Shuffling : Yes Is Question Mandatory : No

Correct Marks : 4 Wrong Marks : 1

Match List - I with List - II :

List - I	List - II
(a) $\text{Ca}(\text{OCl})_2$	(i) Antacid
(b) $\text{CaSO}_4 \cdot \frac{1}{2}\text{H}_2\text{O}$	(ii) Cement
(c) CaO	(iii) Bleach
(d) CaCO_3	(iv) Plaster of Paris

Choose the most appropriate answer from the options given below :

Options :

86435120095. (a)-(i), (b)-(iv), (c)-(iii), (d)-(ii)

86435120096. (a)-(iii), (b)-(ii), (c)-(i), (d)-(iv)

86435120097. (a)-(iii), (b)-(ii), (c)-(iv), (d)-(i)

86435120098. (a)-(iii), (b)-(iv), (c)-(ii), (d)-(i)

Question Number : 37 Question Id : 8643516697 Question Type : MCQ Option Shuffling : Yes Is Question Mandatory : No

Correct Marks : 4 Wrong Marks : 1

ତାଲିକା - I ସହିତ ତାଲିକା - II କୁ ମିଳାଅ :

ତାଲିକା - I	ତାଲିକା - II
(a) $\text{Ca}(\text{OCl})_2$	(i) ପ୍ରତିଅମ୍ଳ
(b) $\text{CaSO}_4 \cdot \frac{1}{2}\text{H}_2\text{O}$	(ii) ସିମେଣ୍ଟ
(c) CaO	(iii) ବ୍ଲିଚ୍
(d) CaCO_3	(iv) ପ୍ଲାଷ୍ଟର ଅଫ୍ ପ୍ୟାରିସ୍

ନିମ୍ନଲିଖିତ ବିକଳ୍ପ ମଧ୍ୟରୁ ସର୍ବାଧିକ ଉପଯୁକ୍ତ ଉତ୍ତରଟି ବାଛ :

Options :

86435120095. (a)-(i), (b)-(iv), (c)-(iii), (d)-(ii)

86435120096. (a)-(iii), (b)-(ii), (c)-(i), (d)-(iv)

86435120097. (a)-(iii), (b)-(ii), (c)-(iv), (d)-(i)

86435120098. (a)-(iii), (b)-(iv), (c)-(ii), (d)-(i)

Question Number : 38 Question Id : 8643516698 Question Type : MCQ Option Shuffling : Yes Is Question Mandatory : No

Correct Marks : 4 Wrong Marks : 1

The number of ionisable hydrogens present in the product obtained from a reaction of phosphorus trichloride and phosphonic acid is :

Options :

86435120099. 1

86435120100. 2

86435120101. 0

86435120102. 3

Question Number : 38 Question Id : 8643516698 Question Type : MCQ Option Shuffling : Yes Is Question Mandatory : No

Correct Marks : 4 Wrong Marks : 1

ଫସଫରସ୍ ଟ୍ରାଇକ୍ଲୋରାଇଡ୍ ଏବଂ ଫସଫରିକ୍ ଅମ୍ଳର ପ୍ରତିକ୍ରିୟାରୁ ମିଳୁଥିବା ଉତ୍ପାଦରେ ଥିବା ଆୟନୀକରଣ ଉଦ୍ଦାନ ସଂଖ୍ୟା ହେଉଛି :

Options :

86435120099. 1

86435120100. 2

86435120101. 0

86435120102. 3

Question Number : 39 Question Id : 8643516699 Question Type : MCQ Option Shuffling : Yes Is

Question Mandatory : No

Correct Marks : 4 Wrong Marks : 1

Match List - I with List - II :

List - I	List - II
(a) Chlorophyll	(i) Ruthenium
(b) Vitamin - B ₁₂	(ii) Platinum
(c) Anticancer drug	(iii) Cobalt
(d) Grubbs catalyst	(iv) Magnesium

Choose the most appropriate answer from the options given below :

Options :

86435120103. (a)-(iii), (b)-(ii), (c)-(iv), (d)-(i)

86435120104. (a)-(iv), (b)-(iii), (c)-(ii), (d)-(i)

86435120105. (a)-(iv), (b)-(ii), (c)-(iii), (d)-(i)

86435120106. (a)-(iv), (b)-(iii), (c)-(i), (d)-(ii)

Question Number : 39 Question Id : 8643516699 Question Type : MCQ Option Shuffling : Yes Is Question Mandatory : No

Correct Marks : 4 Wrong Marks : 1

ତାଲିକା - I ସହିତ ତାଲିକା - II କୁ ମିଳାଅ :

ତାଲିକା - I	ତାଲିକା - II
(a) କ୍ଲୋରୋଫିଲ୍	(i) ରୁଥେନିୟମ୍
(b) ଭିଟାମିନ୍ - B ₁₂	(ii) ପ୍ଲାଟିନମ୍
(c) ଆଣ୍ଟି କେନ୍ଦ୍ରର ଔଷଧ	(iii) କୋବାଲ୍ଟ
(d) ଗ୍ରୁବ୍ସ ଉତ୍ପ୍ରେରକ	(iv) ମାଗ୍ନେସିୟମ୍

ନିମ୍ନଲିଖିତ ବିକଳ୍ପ ମଧ୍ୟରୁ ସର୍ବାଧିକ ଉପଯୁକ୍ତ ଉତ୍ତରଟି ବାଛ :

Options :

86435120103. (a)-(iii), (b)-(ii), (c)-(iv), (d)-(i)

86435120104. (a)-(iv), (b)-(iii), (c)-(ii), (d)-(i)

86435120105. (a)-(iv), (b)-(ii), (c)-(iii), (d)-(i)

86435120106. (a)-(iv), (b)-(iii), (c)-(i), (d)-(ii)

Question Number : 40 Question Id : 8643516700 Question Type : MCQ Option Shuffling : Yes Is
 Question Mandatory : No
 Correct Marks : 4 Wrong Marks : 1

The correct structures of $\text{trans-[NiBr}_2(\text{PPh}_3)_2]$ and meridional- $[\text{Co}(\text{NH}_3)_3(\text{NO}_2)_3]$, respectively, are :

Options :

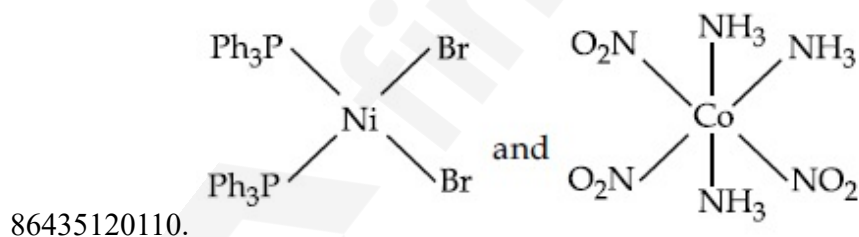
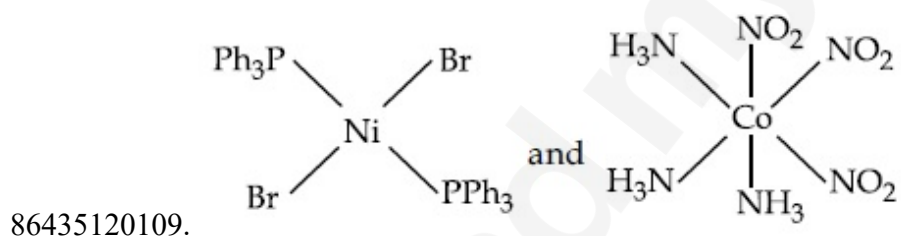
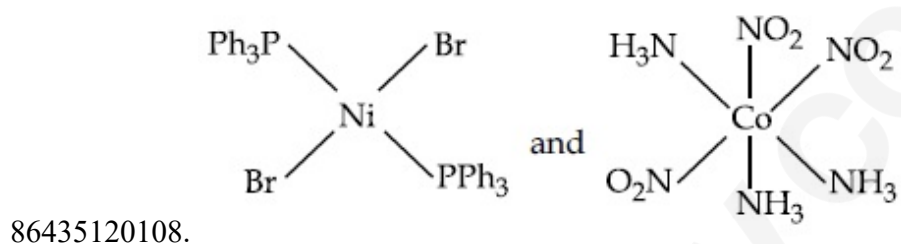
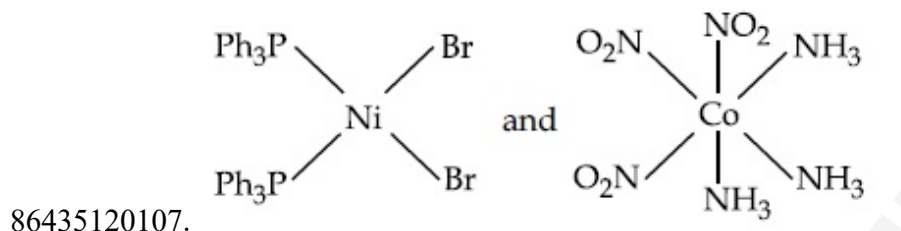

Question Number : 40 Question Id : 8643516700 Question Type : MCQ Option Shuffling : Yes Is
 Question Mandatory : No
 Correct Marks : 4 Wrong Marks : 1

ପ୍ରାୟ- $[\text{NiBr}_2(\text{PPh}_3)_2]$ ଏବଂ ମେରିଡୋନିଆଲ- $[\text{Co}(\text{NH}_3)_3(\text{NO}_2)_3]$ ର ସଠିକ୍ ସଂରଚନା ହେଉଛି ଯଥାକ୍ରମେ :

Options :

86435120112. (A), (B), (C) only

86435120113. (B), (C), (D) only

86435120114. (A), (B), (D) only

Question Number : 41 Question Id : 8643516701 Question Type : MCQ Option Shuffling : Yes Is Question Mandatory : No

Correct Marks : 4 Wrong Marks : 1

ସଠିକ୍ ଉଚ୍ଚିଷ୍ଟିକ ହେଉଛି :

(A) ଭୂମଣ୍ଡଳର ଉତ୍ପତ୍ତା ଏବଂ ଆଲୋକ ରାସାୟନିକ ସ୍ତର ସୃଷ୍ଟି କରିବାରେ ନେତୃତ୍ୱ ନେଇଥାଏ ମିଥେନ୍

(B) ଧାନ ପଡ଼ିଆରୁ ମିଥେନ୍ ସୃଷ୍ଟି ହୋଇଥାଏ

(C) CO₂ ଅପେକ୍ଷା ମିଥେନ୍ ଅଧିକ ଶକ୍ତିଶାଳୀ ଭୂମଣ୍ଡଳକୁ ଉତ୍ତପ୍ତ କରୁଥିବା ଗ୍ୟାସ

(D) ମିଥେନ୍ ବିକାରକ ସ୍ତରର ଏକ ଅଂଶ

ନିମ୍ନଲିଖିତ ବିକଳ୍ପ ମଧ୍ୟରୁ ସର୍ବାଧିକ ଉପଯୁକ୍ତ ଉତ୍ତରଟି ବାଛି :

Options :

86435120111. (A) ଏବଂ (B) କେବଳ

86435120112. (A), (B), (C) କେବଳ

86435120113. (B), (C), (D) କେବଳ

86435120114. (A), (B), (D) କେବଳ

Question Number : 42 Question Id : 8643516702 Question Type : MCQ Option Shuffling : Yes Is Question Mandatory : No

Correct Marks : 4 Wrong Marks : 1

Compound with molecular formula C₃H₆O can show :

Options :

86435120115. Positional isomerism

86435120116. Functional group isomerism

86435120117. Metamerism

86435120118. Both positional isomerism and metamerism

Question Number : 42 Question Id : 8643516702 Question Type : MCQ Option Shuffling : Yes Is Question Mandatory : No

Correct Marks : 4 Wrong Marks : 1

ଆଣବିକ ସୂତ୍ର C_3H_6O ଯୌଗିକଟି ଦେଖାଇ ପାରିବ :

Options :

86435120115. ଅବସ୍ଥାନିକ ସମାବୟବତା

86435120116. କ୍ରିୟାତ୍ମକମୂଳକ ସମାବୟବତା

86435120117. ମେଟାମେରିଜମ୍

86435120118. ଉଭୟ ଅବସ୍ଥାନିକ ଏବଂ ମେଟାମେରିଜମ୍

Question Number : 43 Question Id : 8643516703 Question Type : MCQ Option Shuffling : Yes Is Question Mandatory : No

Correct Marks : 4 Wrong Marks : 1

Match List - I with List - II :

List - I

(Chemicals)

- (a) Alcoholic potassium hydroxide
- (b) Pd/BaSO₄
- (c) BHC (Benzene hexachloride)
- (d) Polyacetylene

List - II

(Use/Preparation/Constituent)

- (i) electrodes in batteries
- (ii) obtained by addition reaction
- (iii) used for β -elimination reaction
- (iv) Lindlar's Catalyst

Choose the most appropriate match :

Options :

86435120119. (a)-(ii), (b)-(i), (c)-(iv), (d)-(iii)

86435120120. (a)-(iii), (b)-(i), (c)-(iv), (d)-(ii)

86435120121. (a)-(ii), (b)-(iv), (c)-(i), (d)-(iii)

86435120122. (a)-(iii), (b)-(iv), (c)-(ii), (d)-(i)

Question Number : 43 Question Id : 8643516703 Question Type : MCQ Option Shuffling : Yes Is Question Mandatory : No

Correct Marks : 4 Wrong Marks : 1

ତାଲିକା - I ସହିତ ତାଲିକା ତାଲିକା - II କୁ ମିଳାଅ :

ତାଲିକା - I

(ରାସାୟନିକ)

- (a) ଆଲକୋହୋଲିକ୍ ପତାସିୟମ୍ ହାଇଡ୍ରୋକ୍ସାଇଡ୍
(b) Pd/BaSO₄
(c) BHC (ବେଞ୍ଜିନ୍ ହେକ୍ସାକ୍ଲୋରାଇଡ୍)
(d) ପଲିଏସିଟିଲିନ୍

ତାଲିକା - II

(ବ୍ୟବହୃତ/ପ୍ରସ୍ତୁତି/ଉପାଦାନ)

- (i) ବ୍ୟାଚେରିରେ ଇଲେକ୍ଟ୍ରୋଲିସିସ୍ ପରି
(ii) ଯୋଗାତ୍ମକ ପ୍ରତିକ୍ରିୟା ଦ୍ୱାରା ମିଳେ
(iii) β-ନିରାକରଣ ପ୍ରତିକ୍ରିୟାରେ ବ୍ୟବହୃତ ହୁଏ
(iv) ଲିଓଲାରଙ୍କ ଉତ୍ପ୍ରେରକ

ସର୍ବାଧିକ ଉପଯୁକ୍ତ ମେଳକଟି ବାଛି :

Options :

86435120119. (a)-(ii), (b)-(i), (c)-(iv), (d)-(iii)

86435120120. (a)-(iii), (b)-(i), (c)-(iv), (d)-(ii)

86435120121. (a)-(ii), (b)-(iv), (c)-(i), (d)-(iii)

86435120122. (a)-(iii), (b)-(iv), (c)-(ii), (d)-(i)

Question Number : 44 Question Id : 8643516704 Question Type : MCQ Option Shuffling : Yes Is Question Mandatory : No

Correct Marks : 4 Wrong Marks : 1

Reaction of Grignard reagent, C₂H₅MgBr with C₈H₈O followed by hydrolysis gives compound "A" which reacts instantly with Lucas reagent to give compound B, C₁₀H₁₃Cl.

The Compound B is :

Options :

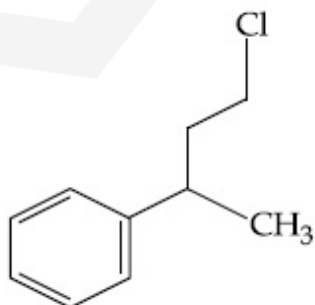

86435120123.

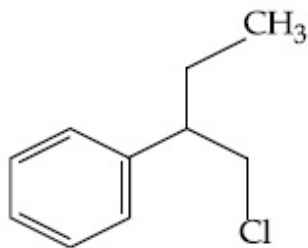

86435120124.

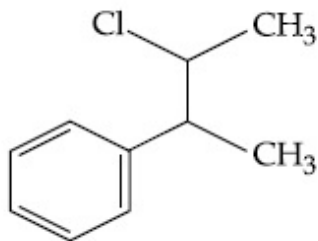

86435120125.

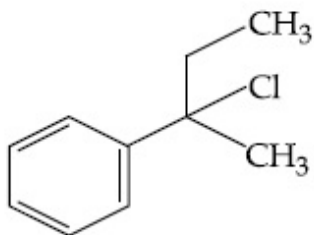

86435120126.

Question Number : 44 Question Id : 8643516704 Question Type : MCQ Option Shuffling : Yes Is Question Mandatory : No

Correct Marks : 4 Wrong Marks : 1

C_8H_8O ସହିତ ଗ୍ରିନ୍ମାଡ଼ ଅଭିକର୍ଷକ C_2H_5MgBr ପ୍ରତିକ୍ରିୟା ପରେ ଜଳଅପଚନ ଦ୍ୱାରା ଉତ୍ପନ୍ନ କରେ ଯୌଗିକ "A" ଯିଏ ଚରକ୍ଷଣାର ଲୁକାସ ଅଭିକର୍ଷକ ସହିତ ପ୍ରତିକ୍ରିୟା କରି ଦେଇଥାଏ ଯୌଗିକ B, $C_{10}H_{13}Cl$ ।

ଯୌଗିକ B ହେଉଛି :

Options :

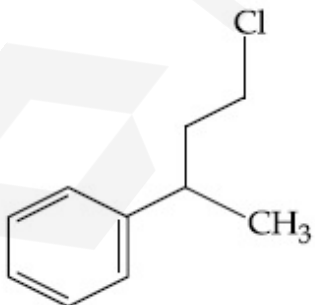

86435120123.

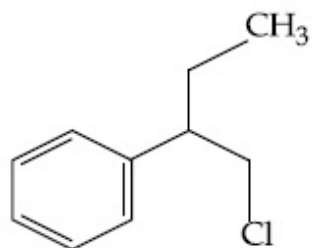

86435120124.

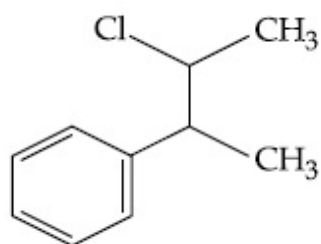

86435120125.

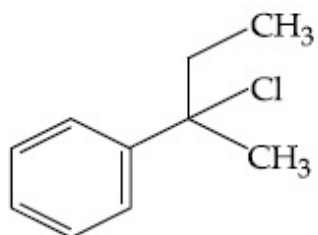

86435120126.

Question Number : 45 Question Id : 8643516705 Question Type : MCQ Option Shuffling : Yes Is Question Mandatory : No

Correct Marks : 4 Wrong Marks : 1

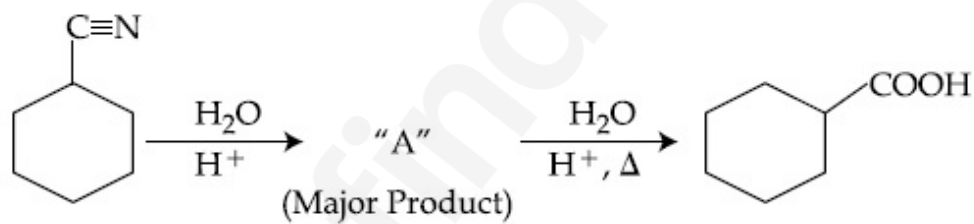

Consider the above chemical reaction and identify product "A" :

Options :

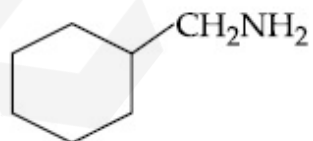

86435120127.

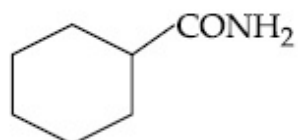

86435120128.

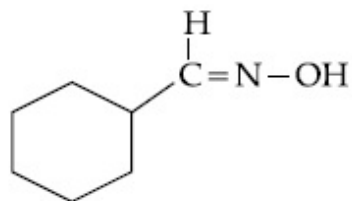

86435120129.

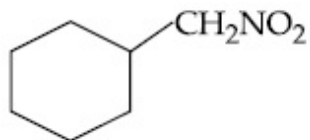

86435120130.

Question Number : 45 Question Id : 8643516705 Question Type : MCQ Option Shuffling : Yes Is Question Mandatory : No

Correct Marks : 4 Wrong Marks : 1

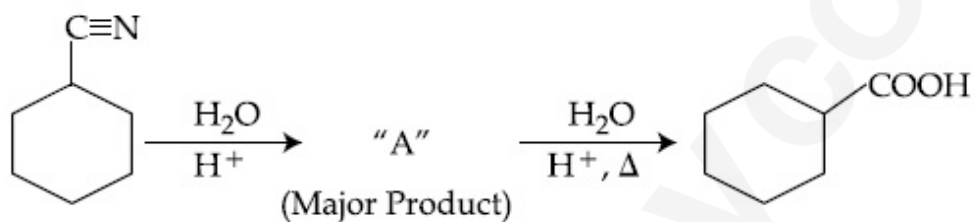

ଉପରଲିଖିତ ରାସାୟନିକ ପ୍ରତିକ୍ରିୟାଟିକୁ ବିଚାର କର ଏବଂ ଉତ୍ପାଦ "A" କୁ ଚିହ୍ନଟିଅ :

Options :

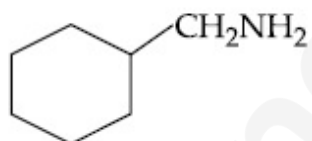

86435120127.

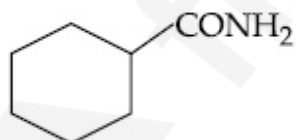

86435120128.

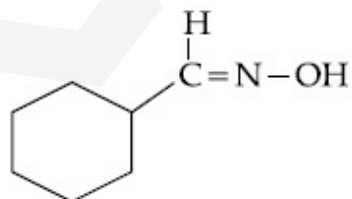

86435120129.

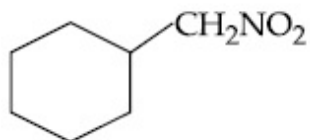

86435120130.

Question Number : 46 Question Id : 8643516706 Question Type : MCQ Option Shuffling : Yes Is Question Mandatory : No

Correct Marks : 4 Wrong Marks : 1

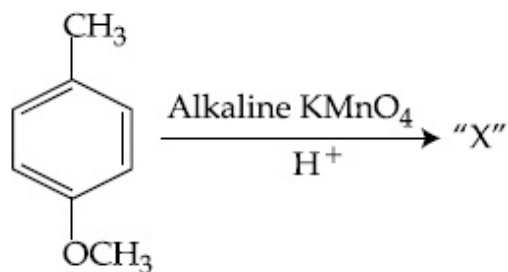

Considering the above chemical reaction, identify the product "X" :

Options :

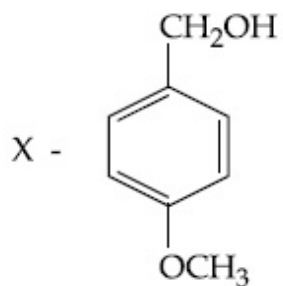

86435120131.

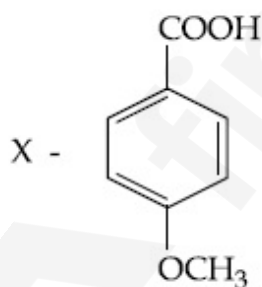

86435120132.

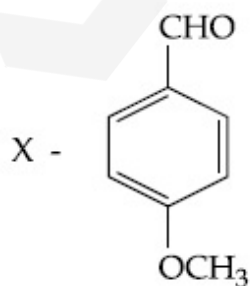

86435120133.

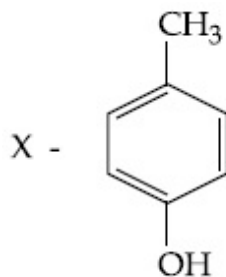

86435120134.

Question Number : 46 Question Id : 8643516706 Question Type : MCQ Option Shuffling : Yes Is Question Mandatory : No

Correct Marks : 4 Wrong Marks : 1

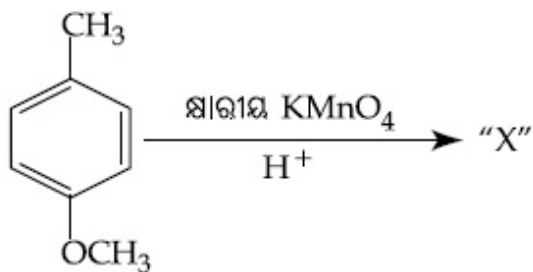

ଉପରଲିଖିତ ରାସାୟନିକ ପ୍ରତିକ୍ରିୟାଟିକୁ ବିଚାର କରି ଉତ୍ପାଦ "X" ଚିହ୍ନଟି ଚିହ୍ନଟି :

Options :

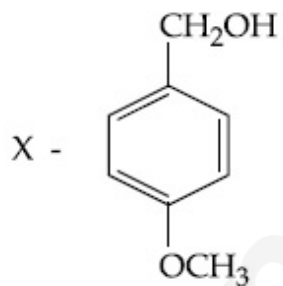

86435120131.

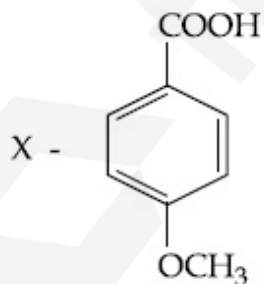

86435120132.

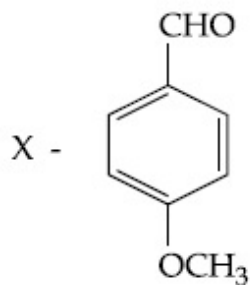

86435120133.

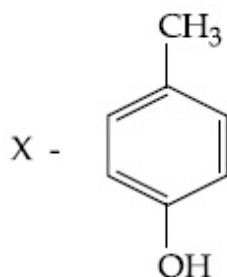

86435120134.

Question Number : 47 Question Id : 8643516707 Question Type : MCQ Option Shuffling : Yes Is Question Mandatory : No Correct Marks : 4 Wrong Marks : 1

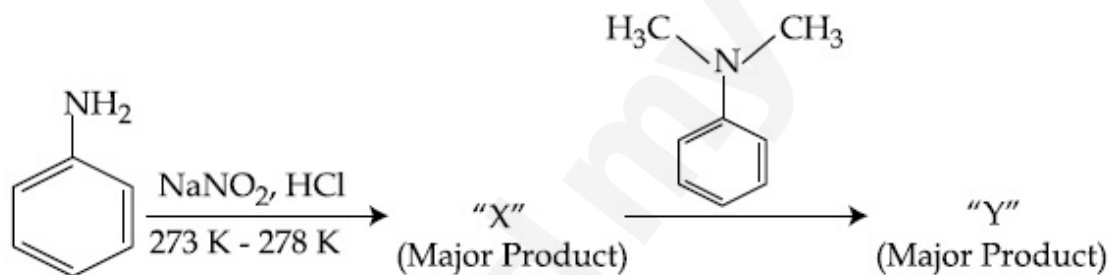

Considering the above reaction, X and Y respectively are :

Options :

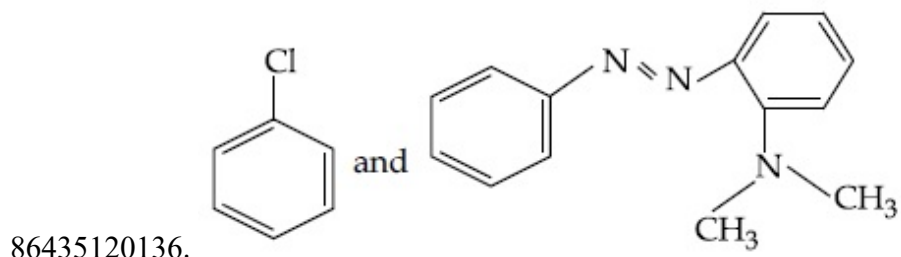
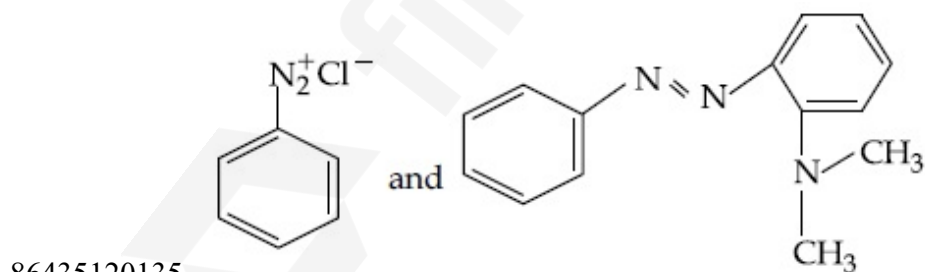

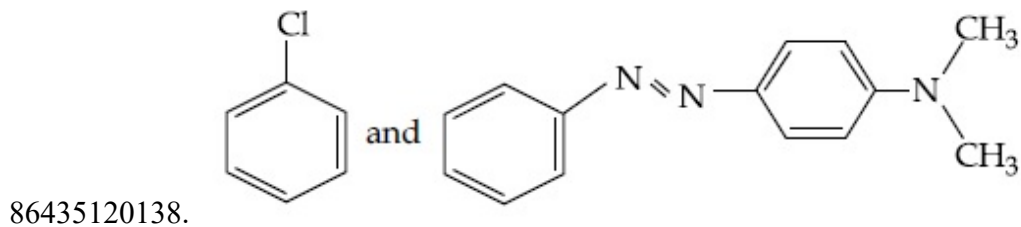
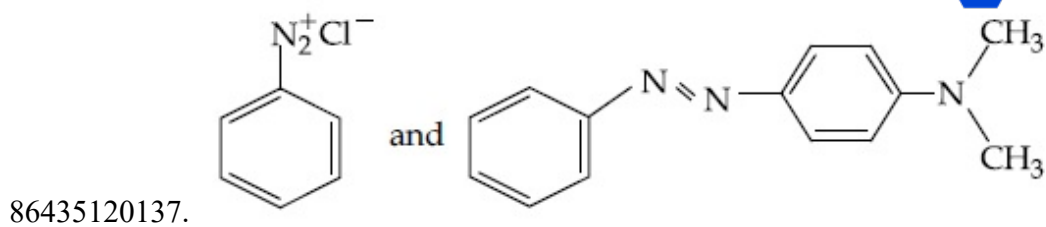

Question Number : 47 Question Id : 8643516707 Question Type : MCQ Option Shuffling : Yes Is Question Mandatory : No Correct Marks : 4 Wrong Marks : 1

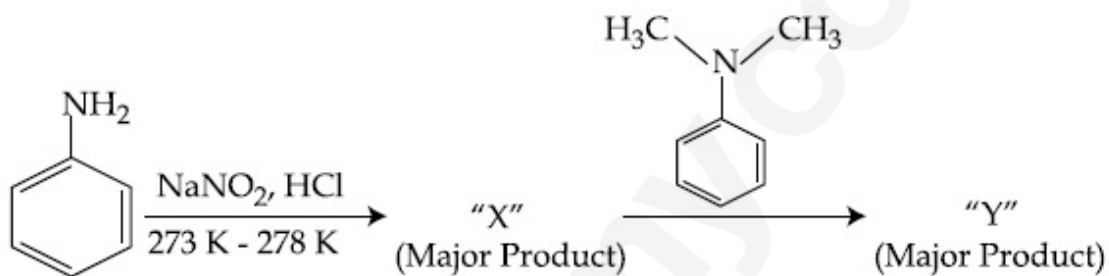

ଉପରଲିଖିତ ପ୍ରତିକ୍ରିୟାକୁ ବିଚାର କରି, X ଏବଂ Y ଯଥାକ୍ରମେ ହେଉଛନ୍ତି :

Options :

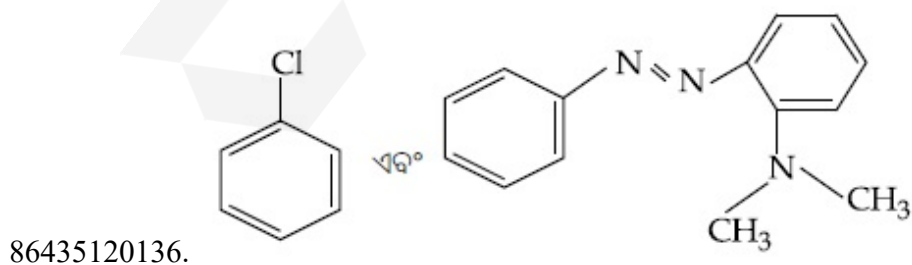
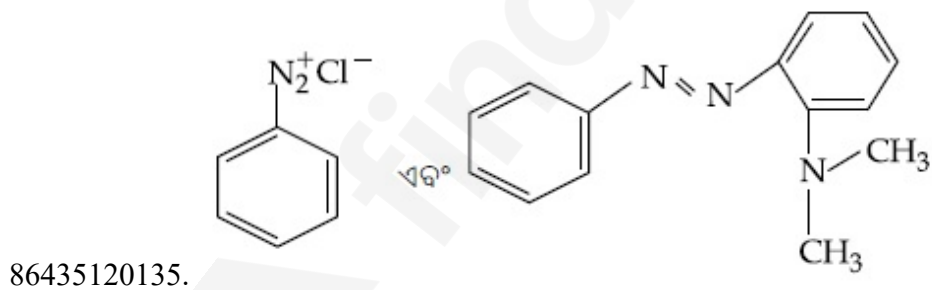

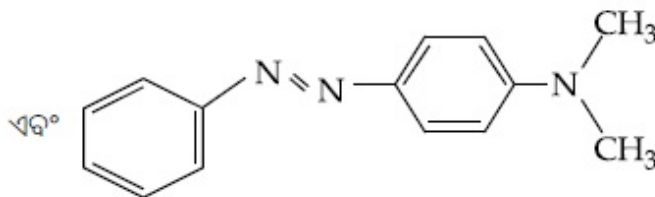
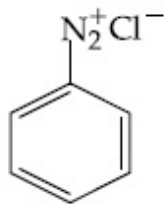

86435120137.

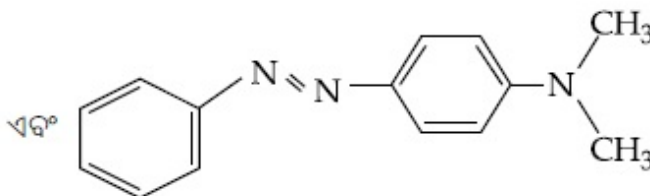
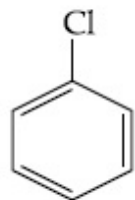

86435120138.

Question Number : 48 Question Id : 8643516708 Question Type : MCQ Option Shuffling : Yes Is Question Mandatory : No

Correct Marks : 4 Wrong Marks : 1

Match List - I with List - II :

List - I	List - II
(Class of Drug)	(Example)
(a) Antacid	(i) Novestrol
(b) Artificial Sweetener	(ii) Cimetidine
(c) Antifertility	(iii) Valium
(d) Tranquilizers	(iv) Alitame

Choose the most appropriate match :

Options :

86435120139. (a)-(ii), (b)-(iv), (c)-(iii), (d)-(i)

86435120140. (a)-(ii), (b)-(iv), (c)-(i), (d)-(iii)

86435120141. (a)-(iv), (b)-(i), (c)-(ii), (d)-(iii)

86435120142. (a)-(iv), (b)-(iii), (c)-(i), (d)-(ii)

Question Number : 48 Question Id : 8643516708 Question Type : MCQ Option Shuffling : Yes Is Question Mandatory : No

Correct Marks : 4 Wrong Marks : 1

ତାଲିକା - I ସହିତ ତାଲିକା- II କୁ ମିଳାଅ :

ତାଲିକା - I (ଔଷଧ ଶ୍ରେଣୀ)	ତାଲିକା - II (ଦୃଷ୍ଟାନ୍ତ)
(a) ପ୍ରତିଅମ୍ଳ	(i) ନୋଭେଷ୍ଟୁଲ୍
(b) କୃତ୍ରିମ ମଧୁରକ	(ii) ସିମେଟିଡିନ
(c) ଅନୁର୍ବରତା	(iii) ଭାଲିଅମ୍
(d) ନିସ୍ତତ୍ତ୍ୱକାରକ	(iv) ଆଲିଚେମ

ସର୍ବାଧିକ ଉପଯୁକ୍ତ ମେଳକଟି ବାଛି :

Options :

86435120139. (a)-(ii), (b)-(iv), (c)-(iii), (d)-(i)

86435120140. (a)-(ii), (b)-(iv), (c)-(i), (d)-(iii)

86435120141. (a)-(iv), (b)-(i), (c)-(ii), (d)-(iii)

86435120142. (a)-(iv), (b)-(iii), (c)-(i), (d)-(ii)

Question Number : 49 Question Id : 8643516709 Question Type : MCQ Option Shuffling : Yes Is Question Mandatory : No

Correct Marks : 4 Wrong Marks : 1

A non-reducing sugar "A" hydrolyses to give two reducing mono saccharides. Sugar A is :

Options :

86435120143. Glucose

86435120144. Fructose

86435120145. Galactose

86435120146. Sucrose

Question Number : 49 Question Id : 8643516709 Question Type : MCQ Option Shuffling : Yes Is Question Mandatory : No

Correct Marks : 4 Wrong Marks : 1

ଏକ ଅଣବିଜାରକ ଚିନି "A" ଜଳ ବିଘଟନ ଦ୍ୱାରା ଦୁଇଟି ମନସାକାରୀରୁ ଉତ୍ପନ୍ନ କରେ । ଚିନି "A" ହେଉଛି :

Options :

86435120143. ଗୁଣ୍ଡୋଇ

86435120144. ପୁଣ୍ଡୋଇ

86435120145. ଗାଲୋକ୍ସୋଇ

86435120146. ସୁକ୍ସୋଇ

Question Number : 50 Question Id : 8643516710 Question Type : MCQ Option Shuffling : Yes Is Question Mandatory : No Correct Marks : 4 Wrong Marks : 1

Reagent, 1-naphthylamine and sulphanilic acid in acetic acid is used for the detection of :

Options :

86435120147. NO_2^-

86435120148. NO_3^-

86435120149. NO

86435120150. N_2O

Question Number : 50 Question Id : 8643516710 Question Type : MCQ Option Shuffling : Yes Is Question Mandatory : No Correct Marks : 4 Wrong Marks : 1

ଏସିଟିକ୍ ଅମ୍ଳରେ ସଲ୍‌ଫାନିଲିକ୍ ଅମ୍ଳ ଏବଂ 1-ନାଫଥାଇଲଆମିନ୍ ଅଭିକର୍ଷକ ନିମ୍ନଲିଖିତ କେଉଁଟିକୁ ଖୋଜି ବାହାର କରିବା ପାଇଁ ବ୍ୟବହୃତ ହୁଏ :

Options :

86435120147. NO_2^-

86435120148. NO_3^-

86435120149. NO

86435120150. N_2O

Chemistry Section B

Section Id :	864351448
Section Number :	4
Section type :	Online
Mandatory or Optional :	Mandatory
Number of Questions :	10
Number of Questions to be attempted :	5
Section Marks :	20
Mark As Answered Required? :	Yes
Sub-Section Number :	1
Sub-Section Id :	864351448
Question Shuffling Allowed :	Yes

Question Number : 51 Question Id : 8643516711 Question Type : SA

Correct Marks : 4 Wrong Marks : 0

Complete combustion of 3 g of ethane gives $x \times 10^{22}$ molecules of water. The value of x is _____ . (Round off to the Nearest Integer).

[Use : $N_A = 6.023 \times 10^{23}$; Atomic masses in u : C : 12.0 ; O : 16.0 ; H : 1.0]

Response Type : Numeric

Evaluation Required For SA : Yes

Show Word Count : Yes

Answers Type : Equal

Text Areas : PlainText

Possible Answers :

100

Question Number : 51 Question Id : 8643516711 Question Type : SA

Correct Marks : 4 Wrong Marks : 0

3 g ଇଥେନ୍‌ର ସମ୍ପୂର୍ଣ୍ଣ ଦହନରେ ଉତ୍ପନ୍ନ ହୁଏ $x \times 10^{22}$ ଜଳ ଅଣୁ । x ର ମୂଲ୍ୟ ହେଉଛି _____ । (ନିକଟତମ ପୂର୍ଣ୍ଣସଂଖ୍ୟାରେ ଉତ୍ତର)

[ବ୍ୟବହାର କର : $N_A = 6.023 \times 10^{23}$; ପାରମାଣବିକ ବସ୍ତୁତ୍ୱ u ରେ : C : 12.0 ; O : 16.0 ; H : 1.0]

Response Type : Numeric

Evaluation Required For SA : Yes

Show Word Count : Yes

Answers Type : Equal

Text Areas : PlainText

Possible Answers :

100

Question Number : 52 Question Id : 8643516712 Question Type : SA

Correct Marks : 4 Wrong Marks : 0

AX is a covalent diatomic molecule where A and X are second row elements of periodic table. Based on Molecular orbital theory, the bond order of AX is 2.5. The total number of electrons in AX is _____. (Round off to the Nearest Integer).

Response Type : Numeric

Evaluation Required For SA : Yes

Show Word Count : Yes

Answers Type : Equal

Text Areas : PlainText

Possible Answers :

100

Question Number : 52 Question Id : 8643516712 Question Type : SA

Correct Marks : 4 Wrong Marks : 0

AX ଗୋଟିଏ ସହସଂଯୋଜୀ ଦ୍ୱିପରମାଣବିକ ଅଣୁ ଯେଉଁଥିରେ A ଏବଂ X ହେଉଛନ୍ତି ପର୍ଯ୍ୟାୟ ସାରଣୀର ଦ୍ୱିତୀୟ ଧାଡ଼ିର ମୌଳିକ । ଅଣୁକକ୍ଷକ ତଥ୍ୟ ଅନୁସାରେ AX ର ବନ୍ଧକ୍ରମ ହେଉଛି 2.5 । AX ରେ ମୋଟ ଇଲେକ୍ଟ୍ରନ୍ ସଂଖ୍ୟା ହେଉଛି _____ । (ନିକଟତମ ପୂର୍ଣ୍ଣସଂଖ୍ୟାରେ ପରିଣତ କର)

Response Type : Numeric

Evaluation Required For SA : Yes

Show Word Count : Yes

Answers Type : Equal

Text Areas : PlainText

Possible Answers :

100

Question Number : 53 Question Id : 8643516713 Question Type : SA

Correct Marks : 4 Wrong Marks : 0

For the reaction

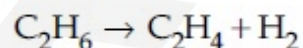

the reaction enthalpy $\Delta_r H =$ _____ kJ mol^{-1} . (Round off to the Nearest Integer).

[Given : Bond enthalpies in kJ mol^{-1} : C–C : 347, C=C : 611;

C–H : 414, H–H : 436]

Response Type : Numeric

Evaluation Required For SA : Yes

Show Word Count : Yes

Answers Type : Equal

Text Areas : PlainText

Possible Answers :

100

Question Number : 53 Question Id : 8643516713 Question Type : SA

Correct Marks : 4 Wrong Marks : 0

ପ୍ରତିକ୍ରିୟା $C_2H_6 \rightarrow C_2H_4 + H_2$ ର ପ୍ରତିକ୍ରିୟାପୂର୍ଣ୍ଣତା $\Delta_r H = \text{_____ kJ mol}^{-1}$ ।

(ନିକଟତମ ପୂର୍ଣ୍ଣସଂଖ୍ୟାରେ ପରିଣତ କର)

[ଦତ୍ତ : ବନ୍ଧ ପୂର୍ଣ୍ଣତାପ ଗୁଡ଼ିକ kJ mol^{-1} ରେ : C-C : 347, C=C : 611;

C-H : 414, H-H : 436]

Response Type : Numeric

Evaluation Required For SA : Yes

Show Word Count : Yes

Answers Type : Equal

Text Areas : PlainText

Possible Answers :

100

Question Number : 54 Question Id : 8643516714 Question Type : SA

Correct Marks : 4 Wrong Marks : 0

2 molal solution of a weak acid HA has a freezing point of 3.885°C . The degree of dissociation of this acid is $\text{_____} \times 10^{-3}$. (Round off to the Nearest Integer).

[Given : Molal depression constant of water = $1.85 \text{ K kg mol}^{-1}$

Freezing point of pure water = 0°C]

Response Type : Numeric

Evaluation Required For SA : Yes

Show Word Count : Yes

Answers Type : Equal

Text Areas : PlainText

Possible Answers :

100

Question Number : 54 Question Id : 8643516714 Question Type : SA

Correct Marks : 4 Wrong Marks : 0

2 molal ଦୁର୍ବଳ ଅମ୍ଳ HA ର ହିମାଙ୍କ 3.885°C । ଏହି ଅମ୍ଳର ଅଣୁ ପୃଥକୀକରଣ ମାତ୍ରା ହେଉଛି $\text{_____} \times 10^{-3}$ ।

(ନିକଟତମ ପୂର୍ଣ୍ଣସଂଖ୍ୟାରେ ପରିଣତ କର)

[ଦତ୍ତ : ଜଳର ମୋଲାଲ ଲଘୁତାପ ସ୍ଥିରାଙ୍କ = $1.85 \text{ K kg mol}^{-1}$

ବିଶୁଦ୍ଧ ଜଳର ହିମାଙ୍କ = 0°C]

Response Type : Numeric

Evaluation Required For SA : Yes

Show Word Count : Yes

Answers Type : Equal

Text Areas : PlainText

Possible Answers :

100

Question Number : 55 Question Id : 8643516715 Question Type : SA

Correct Marks : 4 Wrong Marks : 0

In order to prepare a buffer solution of pH 5.74, sodium acetate is added to acetic acid. If the concentration of acetic acid in the buffer is 1.0 M, the concentration of sodium acetate in the buffer is _____ M. (Round off to the Nearest Integer).

[Given : pKa (acetic acid) = 4.74]

Response Type : Numeric

Evaluation Required For SA : Yes

Show Word Count : Yes

Answers Type : Equal

Text Areas : PlainText

Possible Answers :

100

Question Number : 55 Question Id : 8643516715 Question Type : SA

Correct Marks : 4 Wrong Marks : 0

ଏସିଡିକ୍ ଅମ୍ଳ ସହିତ ସୋଡ଼ିୟମ୍ ଏସିଟେଟ୍ ମିଶାଯାଇ ପ୍ରସ୍ତୁତ ହୋଇଥିବା ବଦର ଦ୍ରବଣର pH 5.74 । ଯଦି ବଦର ଦ୍ରବଣରେ ଏସିଡିକ୍ ଅମ୍ଳର ଗାଢତା 1.0 M ହୁଏ, ବଦରରେ ସୋଡ଼ିୟମ୍ ଏସିଟେଟ୍ ଗାଢତା ହେଉଛି _____ M ।

(ନିକଟତମ ପୂର୍ଣ୍ଣସଂଖ୍ୟାରେ ପରିଣତ କର)

[ଦତ୍ତ pKa (ଏସିଡିକ୍ ଅମ୍ଳ) = 4.74]

Response Type : Numeric

Evaluation Required For SA : Yes

Show Word Count : Yes

Answers Type : Equal

Text Areas : PlainText

Possible Answers :

100

Question Number : 56 Question Id : 8643516716 Question Type : SA

Correct Marks : 4 Wrong Marks : 0

For the reaction

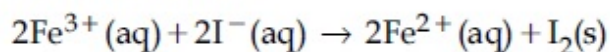

the magnitude of the standard molar free energy change,

$$\Delta_r G_m^\circ = - \text{_____ kJ (Round off to the Nearest Integer)}.$$

$$\left[\begin{array}{l} E^\circ_{\text{Fe}^{2+}/\text{Fe}(\text{s})} = -0.440 \text{ V}; E^\circ_{\text{Fe}^{3+}/\text{Fe}(\text{s})} = -0.036 \text{ V} \\ E^\circ_{\text{I}_2/2\text{I}^{-}} = 0.539 \text{ V}; \quad F = 96500 \text{ C} \end{array} \right]$$

Response Type : Numeric

Evaluation Required For SA : Yes

Show Word Count : Yes

Answers Type : Equal

Text Areas : PlainText

Possible Answers :

100

Question Number : 56 **Question Id :** 8643516716 **Question Type :** SA

Correct Marks : 4 **Wrong Marks :** 0

ପ୍ରତିକ୍ରିୟା $2\text{Fe}^{3+}(\text{aq}) + 2\text{I}^{-}(\text{aq}) \rightarrow 2\text{Fe}^{2+}(\text{aq}) + \text{I}_2(\text{s})$ ରେ ମାନକ ମୋଲାର ମୁକ୍ତ ଶକ୍ତି ପରିବର୍ତ୍ତନର ପରିମାଣ

ହେଉଛି : $\Delta_r G_m^\circ = - \text{_____ kJ}$

(ନିକଟତମ ପୂର୍ଣ୍ଣସଂଖ୍ୟାରେ ପରିଣତ କର)

$$\left[\begin{array}{l} E^\circ_{\text{Fe}^{2+}/\text{Fe}(\text{s})} = -0.440 \text{ V}; E^\circ_{\text{Fe}^{3+}/\text{Fe}(\text{s})} = -0.036 \text{ V} \\ E^\circ_{\text{I}_2/2\text{I}^{-}} = 0.539 \text{ V}; \quad F = 96500 \text{ C} \end{array} \right]$$

Response Type : Numeric

Evaluation Required For SA : Yes

Show Word Count : Yes

Answers Type : Equal

Text Areas : PlainText

Possible Answers :

100

Question Number : 57 **Question Id :** 8643516717 **Question Type :** SA

Correct Marks : 4 **Wrong Marks :** 0

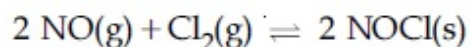

This reaction was studied at -10°C and the following data was obtained

run	$[\text{NO}]_0$	$[\text{Cl}_2]_0$	r_0
1	0.10	0.10	0.18
2	0.10	0.20	0.35
3	0.20	0.20	1.40

$[\text{NO}]_0$ and $[\text{Cl}_2]_0$ are the initial concentrations and r_0 is the initial reaction rate.

The overall order of the reaction is _____. (Round off to the Nearest Integer).

Response Type : Numeric

Evaluation Required For SA : Yes

Show Word Count : Yes

Answers Type : Equal

Text Areas : PlainText

Possible Answers :

100

Question Number : 57 **Question Id :** 8643516717 **Question Type :** SA

Correct Marks : 4 **Wrong Marks :** 0

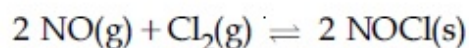

-10°C ତାପମାତ୍ରାରେ ଏହି ପ୍ରତିକ୍ରିୟାଟିକୁ ଅଧ୍ୟୟନ କଲେ ନିମ୍ନଲିଖିତ ତଥ୍ୟ ମିଳିଲା :

run	$[\text{NO}]_0$	$[\text{Cl}_2]_0$	r_0
1	0.10	0.10	0.18
2	0.10	0.20	0.35
3	0.20	0.20	1.40

$[\text{NO}]_0$ ଏବଂ $[\text{Cl}_2]_0$ ହେଉଛି ପ୍ରାରମ୍ଭିକ ଗାତତା ଏବଂ r_0 ହେଉଛି ପ୍ରାରମ୍ଭିକ ପ୍ରତିକ୍ରିୟା ହାର ।

ପ୍ରତିକ୍ରିୟାର ସମୂହ ହାର ହେଉଛି _____ । (ନିକଟତମ ପୂର୍ଣ୍ଣସଂଖ୍ୟାରେ ପରିଣତ କର)

Response Type : Numeric

Evaluation Required For SA : Yes

Show Word Count : Yes

Answers Type : Equal

Text Areas : PlainText

Possible Answers :

100

Question Number : 58 **Question Id :** 8643516718 **Question Type :** SA

Correct Marks : 4 **Wrong Marks :** 0

The total number of unpaired electrons present in the complex $\text{K}_3[\text{Cr}(\text{oxalate})_3]$ is _____.

Response Type : Numeric**Evaluation Required For SA :** Yes**Show Word Count :** Yes**Answers Type :** Equal**Text Areas :** PlainText**Possible Answers :**

100

Question Number : 58 **Question Id :** 8643516718 **Question Type :** SA**Correct Marks :** 4 **Wrong Marks :** 0

$K_3[Cr(oxalate)_3]$ କମ୍ପ୍ଲେକ୍ସରେ ଥିବା ଅଯୋଡ଼ା ଇଲେକ୍ଟ୍ରନ୍‌ଙ୍କ ସର୍ବମୋଟ ସଂଖ୍ୟା ହେଉଛି _____ ।

Response Type : Numeric**Evaluation Required For SA :** Yes**Show Word Count :** Yes**Answers Type :** Equal**Text Areas :** PlainText**Possible Answers :**

100

Question Number : 59 **Question Id :** 8643516719 **Question Type :** SA**Correct Marks :** 4 **Wrong Marks :** 0

_____ grams of 3-Hydroxy propanal (MW = 74) must be dehydrated to produce 7.8 g of acrolein (MW = 56) (C_3H_4O) if the percentage yield is 64. (Round off to the Nearest Integer).

[Given : Atomic masses : C : 12.0 u, H : 1.0 u, O : 16.0 u]

Response Type : Numeric**Evaluation Required For SA :** Yes**Show Word Count :** Yes**Answers Type :** Equal**Text Areas :** PlainText**Possible Answers :**

100

Question Number : 59 **Question Id :** 8643516719 **Question Type :** SA**Correct Marks :** 4 **Wrong Marks :** 0

7.8 g ଆକ୍ରୋଲିନ୍ (MW = 56) (C_3H_4O) ଉତ୍ପନ୍ନ କରିବା ପାଇଁ 3-ହାଇଡ୍ରକ୍ସି ପ୍ରୋପାନାଲ (MW = 74) ନିର୍ଜଳୀକରଣ ପ୍ରକ୍ରିୟାରେ ଆବଶ୍ୟକ ପରିମାଣ _____ g ଯଦି ଶତକଡ଼ା ଉତ୍ପାଦ 64 ହୁଏ ।

(ନିକଟତମ ପୂର୍ଣ୍ଣସଂଖ୍ୟାରେ ପରିଣତ କର)

[ଦତ୍ତ : ଆଣବିକ ସାନ୍ଦ୍ରତା : C : 12.0 u, H : 1.0 u, O : 16.0 u]

Response Type : Numeric

Evaluation Required For SA : Yes

Show Word Count : Yes

Answers Type : Equal

Text Areas : PlainText

Possible Answers :

100

Question Number : 60 **Question Id :** 8643516720 **Question Type :** SA

Correct Marks : 4 **Wrong Marks :** 0

A reaction of 0.1 mole of Benzylamine with bromomethane gave 23 g of Benzyl trimethyl ammonium bromide. The number of moles of bromomethane consumed in this reaction are $n \times 10^{-1}$, when $n = \underline{\hspace{2cm}}$. (Round off to the Nearest Integer).

[Given : Atomic masses : C : 12.0 u, H : 1.0 u, N : 14.0 u, Br : 80.0 u]

Response Type : Numeric

Evaluation Required For SA : Yes

Show Word Count : Yes

Answers Type : Equal

Text Areas : PlainText

Possible Answers :

100

Question Number : 60 **Question Id :** 8643516720 **Question Type :** SA

Correct Marks : 4 **Wrong Marks :** 0

ବ୍ରୋମୋମିଥେନ୍ ସହିତ 0.1 mole ବେଞ୍ଜାଇଲ୍ ଆମିନ ପ୍ରତିକ୍ରିୟା କରି ଦେଇଥାଏ 23 g ବେଞ୍ଜାଇଲ୍ ଟ୍ରାଇମିଥାଇଲ୍ ଆମୋନିୟମ୍ ବ୍ରୋମାଇଡ୍ । ଉକ୍ତ ପ୍ରତିକ୍ରିୟାରେ ବ୍ୟବହୃତ ବ୍ରୋମୋମିଥେନ୍ ମୋଲ ସଂଖ୍ୟା $n \times 10^{-1}$, ଯେତେବେଳେ $n = \underline{\hspace{2cm}}$ । (ନିକଟତମ ପୂର୍ଣ୍ଣସଂଖ୍ୟାରେ ପରିଣତ କର)

[ଦତ୍ତ : ପାରମାଣବିକ ବସ୍ତୁତ୍ୱ C : 12.0 u, H : 1.0 u, N : 14.0 u, Br : 80.0 u]

Response Type : Numeric

Evaluation Required For SA : Yes

Show Word Count : Yes

Answers Type : Equal

Text Areas : PlainText

Possible Answers :

100

Mathematics Section A

Section Id :	864351449
Section Number :	5
Section type :	Online
Mandatory or Optional :	Mandatory

Number of Questions :	20
Number of Questions to be attempted :	20
Section Marks :	80
Mark As Answered Required? :	Yes
Sub-Section Number :	1
Sub-Section Id :	864351449
Question Shuffling Allowed :	Yes

Question Number : 61 Question Id : 8643516721 Question Type : MCQ Option Shuffling : Yes Is Question Mandatory : No

Correct Marks : 4 Wrong Marks : 1

If the functions are defined as $f(x) = \sqrt{x}$ and $g(x) = \sqrt{1-x}$, then what is the common domain of the following functions : $f+g$, $f-g$, f/g , g/f , $g-f$ where

$$(f \pm g)(x) = f(x) \pm g(x), (f/g)(x) = \frac{f(x)}{g(x)}$$

Options :

86435120161. $0 \leq x < 1$

86435120162. $0 < x < 1$

86435120163. $0 \leq x \leq 1$

86435120164. $0 < x \leq 1$

Question Number : 61 Question Id : 8643516721 Question Type : MCQ Option Shuffling : Yes Is Question Mandatory : No

Correct Marks : 4 Wrong Marks : 1

ଯଦି ଫଳନଗୁଡ଼ିକୁ $f(x) = \sqrt{x}$ ଏବଂ $g(x) = \sqrt{1-x}$ ରୂପେ ପ୍ରକାଶ କରାଯାଏ, ତେବେ, ଫଳନଗୁଡ଼ିକ $f+g$, $f-g$, f/g , g/f , $g-f$ ର ସାଧାରଣ ପରିସର କ୍ଷେତ୍ର (ତୋମେନ୍) ଚି ଅଟେ :

$$(f \pm g)(x) = f(x) \pm g(x), (f/g)(x) = \frac{f(x)}{g(x)}$$

Options :

86435120161. $0 \leq x < 1$

86435120162. $0 < x < 1$

86435120163. $0 \leq x \leq 1$

86435120164. $0 < x \leq 1$

Question Number : 62 Question Id : 8643516722 Question Type : MCQ Option Shuffling : Yes Is Question Mandatory : No

Correct Marks : 4 Wrong Marks : 1

If the equation $a|z|^2 + \overline{\alpha z} + \alpha \bar{z} + d = 0$ represents a circle where a, d are real constants, then which of the following condition is correct ?

Options :

86435120165. $|\alpha|^2 - ad \geq 0$ and $a \in \mathbb{R}$

86435120166. $|\alpha|^2 - ad > 0$ and $a \in \mathbb{R} - \{0\}$

86435120167. $|\alpha|^2 - ad \neq 0$

86435120168. $\alpha = 0, a, d \in \mathbb{R}^+$

Question Number : 62 Question Id : 8643516722 Question Type : MCQ Option Shuffling : Yes Is Question Mandatory : No

Correct Marks : 4 Wrong Marks : 1

ଯଦି $a|z|^2 + \overline{\alpha z} + \alpha \bar{z} + d = 0$ ସମୀକରଣଟି ଏକ ବୃତ୍ତକୁ ସୂଚିତ କରେ, ଯେଉଁଠି a, d ବାସ୍ତବ ସ୍ଥିରାଙ୍କ, ତେବେ ନିମ୍ନ ସର୍ତ୍ତ ମଧ୍ୟରୁ କେଉଁଟି ଠିକ୍ ?

Options :

86435120165. $|\alpha|^2 - ad \geq 0$ ଏବଂ $a \in \mathbb{R}$

86435120166. $|\alpha|^2 - ad > 0$ ଏବଂ $a \in \mathbb{R} - \{0\}$

86435120167. $|\alpha|^2 - ad \neq 0$

86435120168. $\alpha = 0, a, d \in \mathbb{R}^+$

Question Number : 63 Question Id : 8643516723 Question Type : MCQ Option Shuffling : Yes Is Question Mandatory : No

Correct Marks : 4 Wrong Marks : 1

Let $A + 2B = \begin{bmatrix} 1 & 2 & 0 \\ 6 & -3 & 3 \\ -5 & 3 & 1 \end{bmatrix}$ and $2A - B = \begin{bmatrix} 2 & -1 & 5 \\ 2 & -1 & 6 \\ 0 & 1 & 2 \end{bmatrix}$. If $\text{Tr}(A)$ denotes the sum of all

diagonal elements of the matrix A , then $\text{Tr}(A) - \text{Tr}(B)$ has value equal to :

Options :

86435120169. 1

86435120170. 2

86435120171. 3

86435120172. 0

Question Number : 63 Question Id : 8643516723 Question Type : MCQ Option Shuffling : Yes Is Question Mandatory : No

Correct Marks : 4 Wrong Marks : 1

ମାନନିଅ $A + 2B = \begin{bmatrix} 1 & 2 & 0 \\ 6 & -3 & 3 \\ -5 & 3 & 1 \end{bmatrix}$ ଏବଂ $2A - B = \begin{bmatrix} 2 & -1 & 5 \\ 2 & -1 & 6 \\ 0 & 1 & 2 \end{bmatrix}$ । ଯଦି ମାଟ୍ରିକ୍ସ (ସାରଣୀ) A ର କର୍ଣ୍ଣର ସମସ୍ତ

ଉପାଦାନ ମାନକର ସମଷ୍ଟିକୁ $\text{Tr}(A)$ ରୂପେ ଚିହ୍ନିତ କରାଯାଏ, ତେବେ $\text{Tr}(A) - \text{Tr}(B)$ ର ମୂଲ୍ୟ ସମାନ :

Options :

86435120169. 1

86435120170. 2

86435120171. 3

86435120172. 0

Question Number : 64 Question Id : 8643516724 Question Type : MCQ Option Shuffling : Yes Is Question Mandatory : No

Correct Marks : 4 Wrong Marks : 1

Let α, β, γ be the real roots of the equation, $x^3 + ax^2 + bx + c = 0$, ($a, b, c \in \mathbf{R}$ and $a, b \neq 0$). If the system of equations (in u, v, w) given by $\alpha u + \beta v + \gamma w = 0$; $\beta u + \gamma v + \alpha w = 0$;

$\gamma u + \alpha v + \beta w = 0$ has non-trivial solution, then the value of $\frac{a^2}{b}$ is :

Options :

86435120173. 0

86435120174. 1

86435120175. 3

86435120176. 5

Question Number : 64 Question Id : 8643516724 Question Type : MCQ Option Shuffling : Yes Is Question Mandatory : No

Correct Marks : 4 Wrong Marks : 1

ମାନିନିଅ (ଧରାଯାଉ) α, β, γ , ସମୀକରଣ $x^3 + ax^2 + bx + c = 0$, ର ($a, b, c \in \mathbf{R}$, $a, b \neq 0$) ବାସ୍ତବ ମୂଳ (ବୀଜ) ଅଟନ୍ତି । ଯଦି (u, v, w ରେ) ସହ ସମୀକରଣ ସମୂହ $\alpha u + \beta v + \gamma w = 0$; $\beta u + \gamma v + \alpha w = 0$; $\gamma u + \alpha v + \beta w = 0$ ର

ଅସାଧାରଣ ସମାଧାନ ଥାଏ, ତେବେ $\frac{a^2}{b}$ ର ମୂଲ୍ୟ ଅଟେ :

Options :

86435120173. 0

86435120174. 1

86435120175. 3

86435120176. 5

Question Number : 65 Question Id : 8643516725 Question Type : MCQ Option Shuffling : Yes Is Question Mandatory : No

Correct Marks : 4 Wrong Marks : 1

The sum of all the 4-digit distinct numbers that can be formed with the digits 1, 2, 2 and 3 is :

Options :

86435120177. 22264

86435120178. 26664

86435120179. 122234

86435120180. 122664

Question Number : 65 Question Id : 8643516725 Question Type : MCQ Option Shuffling : Yes Is Question Mandatory : No

Correct Marks : 4 Wrong Marks : 1

ଅଙ୍କ 1, 2, 2 ଏବଂ 3 କୁ ବ୍ୟବହାର କରି ଗତାଯାଇପାରୁଥିବା ଭିନ୍ନ ଚାରିଅଙ୍କ ବିଶିଷ୍ଟ ସଂଖ୍ୟାମାନଙ୍କର ସମଷ୍ଟି ଅଟେ :

Options :

86435120177. 22264

86435120178. 26664

86435120179. 122234

86435120180. 122664

Question Number : 66 Question Id : 8643516726 Question Type : MCQ Option Shuffling : Yes Is Question Mandatory : No

Correct Marks : 4 Wrong Marks : 1

Let $(1 + x + 2x^2)^{20} = a_0 + a_1x + a_2x^2 + \dots + a_{40}x^{40}$. Then, $a_1 + a_3 + a_5 + \dots + a_{37}$ is equal to :

Options :

86435120181. $2^{19}(2^{20} + 21)$ 86435120182. $2^{20}(2^{20} + 21)$ 86435120183. $2^{19}(2^{20} - 21)$ 86435120184. $2^{20}(2^{20} - 21)$

Question Number : 66 Question Id : 8643516726 Question Type : MCQ Option Shuffling : Yes Is Question Mandatory : No

Correct Marks : 4 Wrong Marks : 1

ମାନିନିଅ $(1 + x + 2x^2)^{20} = a_0 + a_1x + a_2x^2 + \dots + a_{40}x^{40}$ । ଚେତେ $a_1 + a_3 + a_5 + \dots + a_{37}$ ସମାନ :

Options :

86435120181. $2^{19}(2^{20} + 21)$

86435120182. $2^{20}(2^{20} + 21)$

86435120183. $2^{19}(2^{20} - 21)$

86435120184. $2^{20}(2^{20} - 21)$

Question Number : 67 Question Id : 8643516727 Question Type : MCQ Option Shuffling : Yes Is Question Mandatory : No

Correct Marks : 4 Wrong Marks : 1

The value of $3 + \frac{1}{4 + \frac{1}{3 + \frac{1}{4 + \frac{1}{3 + \dots \infty}}}}$ is equal to :

Options :

86435120185. $1.5 + \sqrt{3}$

86435120186. $2 + \sqrt{3}$

86435120187. $3 + 2\sqrt{3}$

86435120188. $4 + \sqrt{3}$

Question Number : 67 Question Id : 8643516727 Question Type : MCQ Option Shuffling : Yes Is Question Mandatory : No

Correct Marks : 4 Wrong Marks : 1

$3 + \frac{1}{4 + \frac{1}{3 + \frac{1}{4 + \frac{1}{3 + \dots \infty}}}}$ ର ମୂଲ୍ୟ ସମ୍ପାଦନ :

Options :

86435120185. $1.5 + \sqrt{3}$

86435120186. $2 + \sqrt{3}$

86435120187. $3 + 2\sqrt{3}$

86435120188. $4 + \sqrt{3}$

Question Number : 68 Question Id : 8643516728 Question Type : MCQ Option Shuffling : Yes Is Question Mandatory : No

Correct Marks : 4 Wrong Marks : 1

$\frac{1}{3^2 - 1} + \frac{1}{5^2 - 1} + \frac{1}{7^2 - 1} + \dots + \frac{1}{(201)^2 - 1}$ is equal to :

Options :

86435120189. $\frac{25}{101}$

86435120190. $\frac{101}{408}$

86435120191. $\frac{99}{400}$

86435120192. $\frac{101}{404}$

Question Number : 68 Question Id : 8643516728 Question Type : MCQ Option Shuffling : Yes Is Question Mandatory : No

Correct Marks : 4 Wrong Marks : 1

$\frac{1}{3^2 - 1} + \frac{1}{5^2 - 1} + \frac{1}{7^2 - 1} + \dots + \frac{1}{(201)^2 - 1}$ ର ସମାନ :

Options :

86435120189. $\frac{25}{101}$

86435120190. $\frac{101}{408}$

$$86435120191. \frac{99}{400}$$

$$86435120192. \frac{101}{404}$$

Question Number : 69 Question Id : 8643516729 Question Type : MCQ Option Shuffling : Yes Is Question Mandatory : No

Correct Marks : 4 Wrong Marks : 1

If α, β are natural numbers such that $100^\alpha - 199^\beta = (100)(100) + (99)(101) + (98)(102) + \dots + (1)(199)$, then the slope of the line passing through (α, β) and origin is :

Options :

$$86435120193. 510$$

$$86435120194. 530$$

$$86435120195. 540$$

$$86435120196. 550$$

Question Number : 69 Question Id : 8643516729 Question Type : MCQ Option Shuffling : Yes Is Question Mandatory : No

Correct Marks : 4 Wrong Marks : 1

ଯଦି α, β ସ୍ୱାଭାବିକ ସଂଖ୍ୟା ଯାହାପାଇଁ $100^\alpha - 199^\beta = (100)(100) + (99)(101) + (98)(102) + \dots + (1)(199)$, ତେବେ (α, β) ଓ ମୂଳବିନ୍ଦୁ ମଧ୍ୟ ଦେଇ ଗଠି କରୁଥିବା ରେଖାର ସ୍ଲୋପ୍ ଅଟେ :

Options :

$$86435120193. 510$$

$$86435120194. 530$$

$$86435120195. 540$$

$$86435120196. 550$$

Question Number : 70 Question Id : 8643516730 Question Type : MCQ Option Shuffling : Yes Is Question Mandatory : No

Correct Marks : 4 Wrong Marks : 1

If $f(x) = \begin{cases} \frac{1}{|x|} & ; |x| \geq 1 \\ ax^2 + b & ; |x| < 1 \end{cases}$ is differentiable at every point of the domain, then the values of

a and b are respectively :

Options :

86435120197. $\frac{1}{2}, \frac{1}{2}$

86435120198. $-\frac{1}{2}, \frac{3}{2}$

86435120199. $\frac{5}{2}, -\frac{3}{2}$

86435120200. $\frac{1}{2}, -\frac{3}{2}$

Question Number : 70 Question Id : 8643516730 Question Type : MCQ Option Shuffling : Yes Is Question Mandatory : No

Correct Marks : 4 Wrong Marks : 1

ଯଦି ଫଳନ $f(x) = \begin{cases} \frac{1}{|x|} & ; |x| \geq 1 \\ ax^2 + b & ; |x| < 1 \end{cases}$ ଟି ଏହାର ପରିସର (ଡୋମେନ୍) ର ପ୍ରତ୍ୟେକ ବିନ୍ଦୁରେ ଅବିଚ୍ଛିନ୍ନ ଓ ଅବକଳନୀୟ,

ତେବେ a ଏବଂ b ର ମୂଲ୍ୟ ଯଥାକ୍ରମେ :

Options :

86435120197. $\frac{1}{2}, \frac{1}{2}$

86435120198. $-\frac{1}{2}, \frac{3}{2}$

86435120199. $\frac{5}{2}, -\frac{3}{2}$

86435120200. $\frac{1}{2}, -\frac{3}{2}$

Question Number : 71 Question Id : 8643516731 Question Type : MCQ Option Shuffling : Yes Is

Question Mandatory : No

Correct Marks : 4 Wrong Marks : 1

The real valued function $f(x) = \frac{\operatorname{cosec}^{-1}x}{\sqrt{x - [x]}}$, where $[x]$ denotes the greatest integer less than or

equal to x , is defined for all x belonging to :

Options :

86435120201. all reals except integers

86435120202. all reals except the interval $[-1, 1]$

86435120203. all non-integers except the interval $[-1, 1]$

86435120204. all integers except 0, $-1, 1$

Question Number : 71 Question Id : 8643516731 Question Type : MCQ Option Shuffling : Yes Is

Question Mandatory : No

Correct Marks : 4 Wrong Marks : 1

ବାସ୍ତବ ମୂଲ୍ୟ ଫଳନ $f(x) = \frac{\operatorname{cosec}^{-1}x}{\sqrt{x - [x]}}$, (ଯେଉଁଠାରେ $[x]$, x ଠାରୁ ସାନ ବା ସମାନ ପାଇଁ ସର୍ବାଧିକ ପୂର୍ଣ୍ଣସଂଖ୍ୟାକୁ ସୂଚିତ

କରେ) ଚିହ୍ନ ବର୍ଣ୍ଣନା କରାଯାଇଅଛି ସମସ୍ତ x ପାଇଁ, ଯେପରି x ରହିବ :

Options :

86435120201. ପୂର୍ଣ୍ଣସଂଖ୍ୟା ବ୍ୟତୀତ ସମସ୍ତ ବାସ୍ତବ ମୂଲ୍ୟ ମଧ୍ୟରେ

86435120202. $[-1, 1]$ ଅନ୍ତରାଳ ବ୍ୟତୀତ ସମସ୍ତ ବାସ୍ତବ ମୂଲ୍ୟ ମଧ୍ୟରେ

86435120203. $[-1, 1]$ ଅନ୍ତରାଳ ବ୍ୟତୀତ ସମସ୍ତ ଅଣ-ପୂର୍ଣ୍ଣସଂଖ୍ୟା ମଧ୍ୟରେ

86435120204. 0, $-1, 1$ ବ୍ୟତୀତ ସମସ୍ତ ପୂର୍ଣ୍ଣସଂଖ୍ୟା ମଧ୍ୟରେ

Question Number : 72 Question Id : 8643516732 Question Type : MCQ Option Shuffling : Yes Is

Question Mandatory : No

Correct Marks : 4 Wrong Marks : 1

If $\lim_{x \rightarrow 0} \frac{\sin^{-1} x - \tan^{-1} x}{3x^3}$ is equal to L, then the value of $(6L + 1)$ is :

Options :

86435120205. $\frac{1}{6}$

86435120206. 6

86435120207. 2

86435120208. $\frac{1}{2}$

Question Number : 72 Question Id : 8643516732 Question Type : MCQ Option Shuffling : Yes Is Question Mandatory : No

Correct Marks : 4 Wrong Marks : 1

ଯଦି $\lim_{x \rightarrow 0} \frac{\sin^{-1} x - \tan^{-1} x}{3x^3} = L$ ହୁଏ, ତେବେ $(6L + 1)$ ର ମୂଲ୍ୟ ଅଟେ :

Options :

86435120205. $\frac{1}{6}$

86435120206. 6

86435120207. 2

86435120208. $\frac{1}{2}$

Question Number : 73 Question Id : 8643516733 Question Type : MCQ Option Shuffling : Yes Is Question Mandatory : No

Correct Marks : 4 Wrong Marks : 1

The integral $\int \frac{(2x - 1) \cos \sqrt{(2x - 1)^2 + 5}}{\sqrt{4x^2 - 4x + 6}} dx$ is equal to :

(where c is a constant of integration)

Options :

86435120209. $\frac{1}{2} \sin \sqrt{(2x+1)^2 + 5} + c$

86435120210. $\frac{1}{2} \sin \sqrt{(2x-1)^2 + 5} + c$

86435120211. $\frac{1}{2} \cos \sqrt{(2x-1)^2 + 5} + c$

86435120212. $\frac{1}{2} \cos \sqrt{(2x+1)^2 + 5} + c$

Question Number : 73 Question Id : 8643516733 Question Type : MCQ Option Shuffling : Yes Is Question Mandatory : No

Correct Marks : 4 Wrong Marks : 1

ସମାକଳନ $\int \frac{(2x-1) \cos \sqrt{(2x-1)^2 + 5}}{\sqrt{4x^2 - 4x + 6}} dx$ ସମାନ ଅଟେ :

(ଯେଉଁଠାରେ c ଏକ ସମାକଳନ ସ୍ଥିରାଙ୍କ)

Options :

86435120209. $\frac{1}{2} \sin \sqrt{(2x+1)^2 + 5} + c$

86435120210. $\frac{1}{2} \sin \sqrt{(2x-1)^2 + 5} + c$

86435120211. $\frac{1}{2} \cos \sqrt{(2x-1)^2 + 5} + c$

86435120212. $\frac{1}{2} \cos \sqrt{(2x+1)^2 + 5} + c$

Question Number : 74 Question Id : 8643516734 Question Type : MCQ Option Shuffling : Yes Is Question Mandatory : No

Correct Marks : 4 Wrong Marks : 1

The differential equation satisfied by the system of parabolas $y^2 = 4a(x+a)$ is :

Options :

86435120213. $y\left(\frac{dy}{dx}\right)^2 + 2x\left(\frac{dy}{dx}\right) - y = 0$

86435120214. $y\left(\frac{dy}{dx}\right) + 2x\left(\frac{dy}{dx}\right) - y = 0$

86435120215. $y\left(\frac{dy}{dx}\right)^2 - 2x\left(\frac{dy}{dx}\right) + y = 0$

86435120216. $y\left(\frac{dy}{dx}\right)^2 - 2x\left(\frac{dy}{dx}\right) - y = 0$

Question Number : 74 Question Id : 8643516734 Question Type : MCQ Option Shuffling : Yes Is Question Mandatory : No

Correct Marks : 4 Wrong Marks : 1

ପରିବୃତ୍ତ ସମୂହ $y^2 = 4a(x + a)$ ଦ୍ୱାରା ଘିଷା ହେଉଥିବା ଅବକଳ ସମୀକରଣଟି ଅଟେ :

Options :

86435120213. $y\left(\frac{dy}{dx}\right)^2 + 2x\left(\frac{dy}{dx}\right) - y = 0$

86435120214. $y\left(\frac{dy}{dx}\right) + 2x\left(\frac{dy}{dx}\right) - y = 0$

86435120215. $y\left(\frac{dy}{dx}\right)^2 - 2x\left(\frac{dy}{dx}\right) + y = 0$

86435120216. $y\left(\frac{dy}{dx}\right)^2 - 2x\left(\frac{dy}{dx}\right) - y = 0$

Question Number : 75 Question Id : 8643516735 Question Type : MCQ Option Shuffling : Yes Is Question Mandatory : No

Correct Marks : 4 Wrong Marks : 1

Choose the correct statement about two circles whose equations are given below :

$$x^2 + y^2 - 10x - 10y + 41 = 0$$

$$x^2 + y^2 - 22x - 10y + 137 = 0$$

Options :

86435120217. circles have two meeting points
86435120218. circles have no meeting point
86435120219. circles have only one meeting point
86435120220. circles have same centre

Question Number : 75 Question Id : 8643516735 Question Type : MCQ Option Shuffling : Yes Is Question Mandatory : No

Correct Marks : 4 Wrong Marks : 1

ଦୁଇ ଦୁଇଟି ବିଷୟରେ ସତ କଥନଟିକୁ ଚୟନ କର (ବାଛ), ଯାହାର ସମୀକରଣ ନିମ୍ନରେ ଦିଆଯାଇଛି ।

$$x^2 + y^2 - 10x - 10y + 41 = 0$$

$$x^2 + y^2 - 22x - 10y + 137 = 0$$

Options :

86435120217. ବୃତ୍ତମାନଙ୍କର ଦୁଇଟି ମିଳନ ବିନ୍ଦୁ ଅଛି
86435120218. ବୃତ୍ତମାନଙ୍କର ମିଳନ ବିନ୍ଦୁ ନାହିଁ
86435120219. ବୃତ୍ତମାନଙ୍କର ମାତ୍ର ଗୋଟିଏ ମିଳନ ବିନ୍ଦୁ ଅଛି
86435120220. ବୃତ୍ତମାନଙ୍କର କେନ୍ଦ୍ର ବିନ୍ଦୁ ଏକା (ସମାନ)

Question Number : 76 Question Id : 8643516736 Question Type : MCQ Option Shuffling : Yes Is Question Mandatory : No

Correct Marks : 4 Wrong Marks : 1

For the four circles M, N, O and P, following four equations are given :

Circle M : $x^2 + y^2 = 1$

Circle N : $x^2 + y^2 - 2x = 0$

Circle O : $x^2 + y^2 - 2x - 2y + 1 = 0$

Circle P : $x^2 + y^2 - 2y = 0$

If the centre of circle M is joined with centre of the circle N, further centre of circle N is joined with centre of the circle O, centre of circle O is joined with the centre of circle P and lastly, centre of circle P is joined with centre of circle M, then these lines form the sides of a :

Options :

86435120221. Rectangle

86435120222. Rhombus

86435120223. Square

86435120224. Parallelogram

Question Number : 76 Question Id : 8643516736 Question Type : MCQ Option Shuffling : Yes Is Question Mandatory : No

Correct Marks : 4 Wrong Marks : 1

ଚାରି ବୃତ୍ତ M, N, O ଏବଂ P ପାଇଁ ନିମ୍ନ ସମୀକରଣ ଦିଆଯାଇଅଛି :

$$\text{ବୃତ୍ତ M : } x^2 + y^2 = 1$$

$$\text{ବୃତ୍ତ N : } x^2 + y^2 - 2x = 0$$

$$\text{ବୃତ୍ତ O : } x^2 + y^2 - 2x - 2y + 1 = 0$$

$$\text{ବୃତ୍ତ P : } x^2 + y^2 - 2y = 0$$

ଯଦି ବୃତ୍ତ M ର କେନ୍ଦ୍ରକୁ ବୃତ୍ତ N ର କେନ୍ଦ୍ର ସହ ଯୋଡ଼ାଯାଏ, ପୁନଶ୍ଚ ବୃତ୍ତ N ର କେନ୍ଦ୍ରକୁ ବୃତ୍ତ O ର କେନ୍ଦ୍ର ସହ, ବୃତ୍ତ O ର କେନ୍ଦ୍ରକୁ ବୃତ୍ତ P ର କେନ୍ଦ୍ର ସହ ଏବଂ ସର୍ବଶେଷରେ ବୃତ୍ତ P ର କେନ୍ଦ୍ରକୁ ବୃତ୍ତ M ର କେନ୍ଦ୍ର ସହ ଯୋଡ଼ାଯାଏ, ତେବେ ଏହି ରେଖାଗୁଡ଼ିକୁ ପାର୍ଶ୍ୱରୂପେ ଚିହ୍ନିତ କରି ଗଜାଯାଇଥିବା ଚିତ୍ରଟି ଗୋଟିଏ :

Options :

86435120221. ଆୟତକ୍ଷେତ୍ର

86435120222. ରମ୍ଭସ୍

86435120223. ବର୍ଗକ୍ଷେତ୍ର

86435120224. ସାମାନ୍ତରିକ କ୍ଷେତ୍ର

Question Number : 77 Question Id : 8643516737 Question Type : MCQ Option Shuffling : Yes Is Question Mandatory : No

Correct Marks : 4 Wrong Marks : 1

The number of integral values of m so that the abscissa of point of intersection of lines $3x + 4y = 9$ and $y = mx + 1$ is also an integer, is :

Options :

86435120225. 0

86435120226. 1

86435120227. 2

86435120228. 3

Question Number : 77 Question Id : 8643516737 Question Type : MCQ Option Shuffling : Yes Is Question Mandatory : No

Correct Marks : 4 Wrong Marks : 1

m ର କେତୋଟି ପୂର୍ଣ୍ଣସଂଖ୍ୟା ମୂଲ୍ୟ ପାଇଁ ରେଖାଦ୍ୱୟ $3x + 4y = 9$ ଏବଂ $y = mx + 1$ ର ଛେଦ ବିନ୍ଦୁର x -ସ୍ଥାନାଙ୍କ ଏକ ପୂର୍ଣ୍ଣସଂଖ୍ୟା ଅଟେ :

Options :

86435120225. 0

86435120226. 1

86435120227. 2

86435120228. 3

Question Number : 78 Question Id : 8643516738 Question Type : MCQ Option Shuffling : Yes Is Question Mandatory : No

Correct Marks : 4 Wrong Marks : 1

The equation of one of the straight lines which passes through the point $(1, 3)$ and makes an angle $\tan^{-1}(\sqrt{2})$ with the straight line, $y + 1 = 3\sqrt{2}x$ is :

Options :

86435120229. $4\sqrt{2}x + 5y - (15 + 4\sqrt{2}) = 0$ 86435120230. $4\sqrt{2}x - 5y - (5 + 4\sqrt{2}) = 0$ 86435120231. $5\sqrt{2}x + 4y - (15 + 4\sqrt{2}) = 0$ 86435120232. $4\sqrt{2}x + 5y - 4\sqrt{2} = 0$

Question Number : 78 Question Id : 8643516738 Question Type : MCQ Option Shuffling : Yes Is

Question Mandatory : No

Correct Marks : 4 Wrong Marks : 1

ବିନ୍ଦୁ $(1, 3)$ ମଧ୍ୟ ଦେଇ ଗଠି କରୁଥିବା ଏବଂ ସରଳରେଖା $y + 1 = 3\sqrt{2}x$ ସହ $\tan^{-1}(\sqrt{2})$ କୋଣ ଉତ୍ପନ୍ନ କରୁଥିବା ସରଳରେଖାଟିର ସମୀକରଣ ଅଟେ :

Options :

86435120229. $4\sqrt{2}x + 5y - (15 + 4\sqrt{2}) = 0$

86435120230. $4\sqrt{2}x - 5y - (5 + 4\sqrt{2}) = 0$

86435120231. $5\sqrt{2}x + 4y - (15 + 4\sqrt{2}) = 0$

86435120232. $4\sqrt{2}x + 5y - 4\sqrt{2} = 0$

Question Number : 79 Question Id : 8643516739 Question Type : MCQ Option Shuffling : Yes Is Question Mandatory : No

Correct Marks : 4 Wrong Marks : 1

The solutions of the equation

$$\begin{vmatrix} 1 + \sin^2 x & \sin^2 x & \sin^2 x \\ \cos^2 x & 1 + \cos^2 x & \cos^2 x \\ 4 \sin 2x & 4 \sin 2x & 1 + 4 \sin 2x \end{vmatrix} = 0, (0 < x < \pi), \text{ are :}$$

Options :

86435120233. $\frac{\pi}{6}, \frac{5\pi}{6}$

86435120234. $\frac{5\pi}{12}, \frac{7\pi}{12}$

86435120235. $\frac{7\pi}{12}, \frac{11\pi}{12}$

86435120236. $\frac{\pi}{12}, \frac{\pi}{6}$

Question Number : 79 Question Id : 8643516739 Question Type : MCQ Option Shuffling : Yes Is Question Mandatory : No

Correct Marks : 4 Wrong Marks : 1

$$\text{ସମୀକରଣ } \begin{vmatrix} 1 + \sin^2 x & \sin^2 x & \sin^2 x \\ \cos^2 x & 1 + \cos^2 x & \cos^2 x \\ 4 \sin 2x & 4 \sin 2x & 1 + 4 \sin 2x \end{vmatrix} = 0, (0 < x < \pi) \text{ ର ସମାଧାନଗୁଡ଼ିକ ଅଟନ୍ତି :}$$

Options :

86435120233. $\frac{\pi}{6}, \frac{5\pi}{6}$

86435120234. $\frac{5\pi}{12}, \frac{7\pi}{12}$

86435120235. $\frac{7\pi}{12}, \frac{11\pi}{12}$

86435120236. $\frac{\pi}{12}, \frac{\pi}{6}$

Question Number : 80 Question Id : 8643516740 Question Type : MCQ Option Shuffling : Yes Is Question Mandatory : No

Correct Marks : 4 Wrong Marks : 1

A vector \vec{a} has components $3p$ and 1 with respect to a rectangular cartesian system. This system is rotated through a certain angle about the origin in the counter clockwise sense. If, with respect to new system, \vec{a} has components $p+1$ and $\sqrt{10}$, then a value of p is equal to :

Options :

86435120237. 1

86435120238. -1

86435120239. $\frac{4}{5}$

86435120240. $-\frac{5}{4}$

Question Number : 80 Question Id : 8643516740 Question Type : MCQ Option Shuffling : Yes Is Question Mandatory : No Correct Marks : 4 Wrong Marks : 1

ଏକ ଆୟତାକାର ନିର୍ଦ୍ଦେଶାଙ୍କ ପ୍ରଣାଳୀ(କାର୍ଟେଜୀୟ ପ୍ରଣାଳୀ) ରେ ଗୋଟିଏ ଦିଗାଙ୍କ \vec{a} ର ଉପାଦାନ ଅଂଶଗୁଡ଼ିକ $3p$ ଏବଂ 11 ଏହି ପ୍ରଣାଳୀକୁ ମୂଳବିନ୍ଦୁଠାରେ ଘଣ୍ଟାର ବିପରୀତ ଦିଗରେ ଏକ ନିର୍ଦ୍ଦିଷ୍ଟ କୋଣମାପରେ ଘୂରାଇ ଦିଆଗଲା । ଯଦି ନୂତନ ପ୍ରଣାଳୀରେ \vec{a} ର ଉପାଦାନ ଅଂଶଗୁଡ଼ିକ $p+1$ ଏବଂ $\sqrt{10}$ ହୁଅନ୍ତି, ତେବେ p ର ମୂଲ୍ୟ ସମାନ :

Options :

86435120237. 1

86435120238. -1

86435120239. $\frac{4}{5}$

86435120240. $-\frac{5}{4}$

Mathematics Section B

Section Id :	864351450
Section Number :	6
Section type :	Online
Mandatory or Optional :	Mandatory
Number of Questions :	10
Number of Questions to be attempted :	5
Section Marks :	20
Mark As Answered Required? :	Yes
Sub-Section Number :	1
Sub-Section Id :	864351450
Question Shuffling Allowed :	Yes

Question Number : 81 Question Id : 8643516741 Question Type : SA Correct Marks : 4 Wrong Marks : 0

Let z_1, z_2 be the roots of the equation $z^2 + az + 12 = 0$ and z_1, z_2 form an equilateral triangle with origin. Then, the value of $|a|$ is _____.

Response Type : Numeric

Evaluation Required For SA : Yes

Show Word Count : Yes

Answers Type : Equal

Text Areas : PlainText

Possible Answers :

100

Question Number : 81 Question Id : 8643516741 Question Type : SA

Correct Marks : 4 Wrong Marks : 0

ମାନିନିଅ z_1, z_2 ସମୀକରଣ $z^2 + az + 12 = 0$ ର ବୀଜ ଅଟନ୍ତି ଏବଂ z_1, z_2 ମୂଳବିନ୍ଦୁ ସହ ଏକ ସମବାହୁ ତ୍ରିଭୁଜ ଚିତାରି କରନ୍ତି, ତେବେ $|a|$ ର ମୂଲ୍ୟ ଅଟେ _____ ।

Response Type : Numeric

Evaluation Required For SA : Yes

Show Word Count : Yes

Answers Type : Equal

Text Areas : PlainText

Possible Answers :

100

Question Number : 82 Question Id : 8643516742 Question Type : SA

Correct Marks : 4 Wrong Marks : 0

Let $f(x)$ and $g(x)$ be two functions satisfying $f(x^2) + g(4-x) = 4x^3$ and $g(4-x) + g(x) = 0$, then

the value of $\int_{-4}^4 f(x^2) dx$ is _____.

Response Type : Numeric

Evaluation Required For SA : Yes

Show Word Count : Yes

Answers Type : Equal

Text Areas : PlainText

Possible Answers :

100

Question Number : 82 Question Id : 8643516742 Question Type : SA

Correct Marks : 4 Wrong Marks : 0

ମାନିନିଅ $f(x)$ ଏବଂ $g(x)$ ଦୁଇଟି ଫଳନ ଯାହା $f(x^2) + g(4-x) = 4x^3$ ଓ $g(4-x) + g(x) = 0$ କୁ ସନ୍ତୁଷ୍ଟ (ସିଦ୍ଧ)

କରନ୍ତି, ତେବେ $\int_{-4}^4 f(x^2) dx$ ର ମୂଲ୍ୟ ଅଟେ _____ ।

Response Type : Numeric

Evaluation Required For SA : Yes

Show Word Count : Yes

Answers Type : Equal

Text Areas : PlainText

Possible Answers :

100

Question Number : 83 **Question Id :** 8643516743 **Question Type :** SA

Correct Marks : 4 **Wrong Marks :** 0

If $f(x) = \int \frac{5x^8 + 7x^6}{(x^2 + 1 + 2x^7)^2} dx$, ($x \geq 0$), $f(0) = 0$ and $f(1) = \frac{1}{K}$, then the value of K is

_____.

Response Type : Numeric

Evaluation Required For SA : Yes

Show Word Count : Yes

Answers Type : Equal

Text Areas : PlainText

Possible Answers :

100

Question Number : 83 **Question Id :** 8643516743 **Question Type :** SA

Correct Marks : 4 **Wrong Marks :** 0

ଯଦି $f(x) = \int \frac{5x^8 + 7x^6}{(x^2 + 1 + 2x^7)^2} dx$, ($x \geq 0$), $f(0) = 0$ ଏବଂ $f(1) = \frac{1}{K}$, ତେବେ K ର ମୂଲ୍ୟ ଅଟେ

_____ ।

Response Type : Numeric

Evaluation Required For SA : Yes

Show Word Count : Yes

Answers Type : Equal

Text Areas : PlainText

Possible Answers :

100

Question Number : 84 **Question Id :** 8643516744 **Question Type :** SA

Correct Marks : 4 **Wrong Marks :** 0

A square ABCD has all its vertices on the curve $x^2y^2 = 1$. The midpoints of its sides also lie on the same curve. Then, the square of area of ABCD is _____.

Response Type : Numeric

Evaluation Required For SA : Yes

Show Word Count : Yes

Answers Type : Equal

Text Areas : PlainText

Possible Answers :

100

Question Number : 84 Question Id : 8643516744 Question Type : SA

Correct Marks : 4 Wrong Marks : 0

ଏକ ବର୍ଗକ୍ଷେତ୍ର ABCD ର ସମସ୍ତ ଶୀର୍ଷବିନ୍ଦୁ ବକ୍ରରେଖା $x^2 - y^2 = 1$ ଉପରେ ଅବସ୍ଥିତ । ଏହି ବର୍ଗକ୍ଷେତ୍ରର ପାର୍ଶ୍ଵମାନଙ୍କର ମଧ୍ୟବିନ୍ଦୁ ମଧ୍ୟ ସେହି ଏକା ବକ୍ରରେଖା ଉପରେ ଅବସ୍ଥିତ । ତେବେ ABCD ବର୍ଗକ୍ଷେତ୍ରର କ୍ଷେତ୍ରଫଳର ବର୍ଗ ଅଟେ _____ ।

Response Type : Numeric

Evaluation Required For SA : Yes

Show Word Count : Yes

Answers Type : Equal

Text Areas : PlainText

Possible Answers :

100

Question Number : 85 Question Id : 8643516745 Question Type : SA

Correct Marks : 4 Wrong Marks : 0

Let the plane $ax + by + cz + d = 0$ bisect the line joining the points $(4, -3, 1)$ and $(2, 3, -5)$ at the right angles. If a, b, c, d are integers, then the minimum value of $(a^2 + b^2 + c^2 + d^2)$ is _____.

Response Type : Numeric

Evaluation Required For SA : Yes

Show Word Count : Yes

Answers Type : Equal

Text Areas : PlainText

Possible Answers :

100

Question Number : 85 Question Id : 8643516745 Question Type : SA

Correct Marks : 4 Wrong Marks : 0

ମାନନିଅ ବିନ୍ଦୁ $(4, -3, 1)$ ଏବଂ $(2, 3, -5)$ କୁ ଯୋଗ କରୁଥିବା ରେଖାକୁ ସମତଳ $ax + by + cz + d = 0$ ସମକୋଣରେ ସମବିଖଣ୍ଡ କରେ । ଯଦି a, b, c, d ପୂର୍ଣ୍ଣସଂଖ୍ୟା ହୁଅନ୍ତି, ତେବେ $(a^2 + b^2 + c^2 + d^2)$ ର ନ୍ୟୁନତମ(ସର୍ବନିମ୍ନ) ମୂଲ୍ୟ ଅଟେ _____ ।

Response Type : Numeric

Evaluation Required For SA : Yes

Show Word Count : Yes

Answers Type : Equal

Text Areas : PlainText

Possible Answers :

100

Question Number : 86 Question Id : 8643516746 Question Type : SA

Correct Marks : 4 Wrong Marks : 0

The equation of the planes parallel to the plane $x - 2y + 2z - 3 = 0$ which are at unit distance from the point $(1, 2, 3)$ is $ax + by + cz + d = 0$. If $(b - d) = K(c - a)$, then the positive value of K is _____.

Response Type : Numeric

Evaluation Required For SA : Yes

Show Word Count : Yes

Answers Type : Equal

Text Areas : PlainText

Possible Answers :

100

Question Number : 86 Question Id : 8643516746 Question Type : SA

Correct Marks : 4 Wrong Marks : 0

ସମତଳ $x - 2y + 2z - 3 = 0$ ସହ ସମାନ୍ତର ତଥା ବିନ୍ଦୁ $(1, 2, 3)$ ଠାରୁ ଏକ ଏକକ ଦୂରତ୍ୱରେ ଥିବା ସମତଳର ସମୀକରଣ $ax + by + cz + d = 0$ । ଯଦି $(b - d) = K(c - a)$, ତେବେ K ର ଧନାତ୍ମକ ମୂଲ୍ୟ ଅଟେ _____ ।

Response Type : Numeric

Evaluation Required For SA : Yes

Show Word Count : Yes

Answers Type : Equal

Text Areas : PlainText

Possible Answers :

100

Question Number : 87 Question Id : 8643516747 Question Type : SA

Correct Marks : 4 Wrong Marks : 0

The mean age of 25 teachers in a school is 40 years. A teacher retires at the age of 60 years and a new teacher is appointed in his place. If the mean age of the teachers in this school now is 39 years, then the age (in years) of the newly appointed teacher is _____.

Response Type : Numeric

Evaluation Required For SA : Yes

Show Word Count : Yes

Answers Type : Equal

Text Areas : PlainText

Possible Answers :

100

Question Number : 87 Question Id : 8643516747 Question Type : SA

Correct Marks : 4 Wrong Marks : 0

ଏକ ସ୍କୁଲରେ 25 ଜଣ ଶିକ୍ଷକଙ୍କର ମଧ୍ୟ ଆୟୁ (ମିନି ଏଜ) 40 ବର୍ଷ ଅଟେ । ଜଣେ ଶିକ୍ଷକ 60 ବର୍ଷରେ ଅବସର ନିଏ ଓ ତା ଛାନରେ ଏକ ନୂଆ ଶିକ୍ଷକଙ୍କୁ ନିଯୁକ୍ତି ଦିଆଯାଏ । ଯଦି ବର୍ତ୍ତମାନ ଶିକ୍ଷକମାନଙ୍କର ମଧ୍ୟ ଆୟୁ 39 ବର୍ଷ ହୁଏ, ତେବେ ନୂତନ ନିଯୁକ୍ତି ପାଇଥିବା ଶିକ୍ଷକଙ୍କର ବୟସ (ବର୍ଷରେ) ଅଟେ _____ ।

Response Type : Numeric

Evaluation Required For SA : Yes

Show Word Count : Yes

Answers Type : Equal

Text Areas : PlainText

Possible Answers :

100

Question Number : 88 Question Id : 8643516748 Question Type : SA

Correct Marks : 4 Wrong Marks : 0

The number of times the digit 3 will be written when listing the integers from 1 to 1000 is

_____.

Response Type : Numeric

Evaluation Required For SA : Yes

Show Word Count : Yes

Answers Type : Equal

Text Areas : PlainText

Possible Answers :

100

Question Number : 88 Question Id : 8643516748 Question Type : SA

Correct Marks : 4 Wrong Marks : 0

ଏକ ଠାରୁ 1000 ପର୍ଯ୍ୟନ୍ତ ପୂର୍ଣ୍ଣସଂଖ୍ୟାକୁ ଗୁଣିବା ସମୟରେ, ଅଙ୍କ 3 କୁ ଲେଖିଥିବା ଥର (କେତେଥର) ସଂଖ୍ୟା ଅଟେ

_____ ।

Response Type : Numeric

Evaluation Required For SA : Yes

Show Word Count : Yes

Answers Type : Equal

Text Areas : PlainText

Possible Answers :

100

Question Number : 89 Question Id : 8643516749 Question Type : SA

Correct Marks : 4 Wrong Marks : 0

The missing value in the following figure is _____.

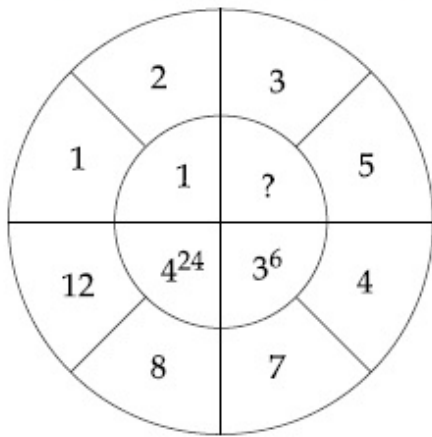

Response Type : Numeric

Evaluation Required For SA : Yes

Show Word Count : Yes

Answers Type : Equal

Text Areas : PlainText

Possible Answers :

100

Question Number : 89 **Question Id :** 8643516749 **Question Type :** SA

Correct Marks : 4 **Wrong Marks :** 0

ନିମ୍ନ ଚିତ୍ରରେ ଅନୁପସ୍ଥିତ (ଲେଖା ହୋଇନଥିବା) ମୂଲ୍ୟ ଅଟେ _____ ।

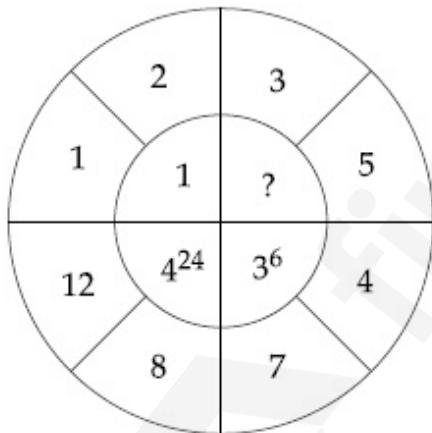

Response Type : Numeric

Evaluation Required For SA : Yes

Show Word Count : Yes

Answers Type : Equal

Text Areas : PlainText

Possible Answers :

100

Question Number : 90 **Question Id :** 8643516750 **Question Type :** SA

Correct Marks : 4 **Wrong Marks :** 0

The number of solutions of the equation $|\cot x| = \cot x + \frac{1}{\sin x}$ in the interval $[0, 2\pi]$ is

_____.

Response Type : Numeric

Evaluation Required For SA : Yes

Show Word Count : Yes

Answers Type : Equal

Text Areas : PlainText

Possible Answers :

100

Question Number : 90 **Question Id :** 8643516750 **Question Type :** SA

Correct Marks : 4 **Wrong Marks :** 0

ଅନ୍ତରାଳ $[0, 2\pi]$ ରେ ସମୀକରଣ $|\cot x| = \cot x + \frac{1}{\sin x}$ ର ସମାଧାନ ସଂଖ୍ୟା ଅଟେ _____।

Response Type : Numeric

Evaluation Required For SA : Yes

Show Word Count : Yes

Answers Type : Equal

Text Areas : PlainText

Possible Answers :

100