

National Testing Agency

Question Paper Name :	B TECH EU 18th March 2021 Shift 1
Subject Name :	B TECH EU
Creation Date :	2021-03-18 14:10:30
Duration :	180
Number of Questions :	90
Total Marks :	300
Display Marks:	Yes

B TECH EU

Group Number :	1
Group Id :	86435176
Group Maximum Duration :	0
Group Minimum Duration :	180
Show Attended Group? :	No
Edit Attended Group? :	No
Break time :	0
Group Marks :	300
Is this Group for Examiner? :	No

Physics Section A

Section Id :	864351451
Section Number :	1
Section type :	Online
Mandatory or Optional :	Mandatory
Number of Questions :	20
Number of Questions to be attempted :	20
Section Marks :	80
Mark As Answered Required? :	Yes
Sub-Section Number :	1
Sub-Section Id :	864351451
Question Shuffling Allowed :	Yes

Question Number : 1 Question Id : 8643516751 Question Type : MCQ Option Shuffling : Yes Is Question Mandatory : No Correct Marks : 4 Wrong Marks : 1

An oil drop of radius 2 mm with a density 3 g cm^{-3} is held stationary under a constant electric field $3.55 \times 10^5 \text{ V m}^{-1}$ in the Millikan's oil drop experiment. What is the number of excess electrons that the oil drop will possess ?

Consider $g = 9.81 \text{ m/s}^2$

Options :

86435120251. 17.3×10^{10}

86435120252. 1.73×10^{10}

86435120253. 1.73×10^{12}

86435120254. 48.8×10^{11}

Question Number : 1 Question Id : 8643516751 Question Type : MCQ Option Shuffling : Yes Is

Question Mandatory : No

Correct Marks : 4 Wrong Marks : 1

ملیکن کے تیل کی بوند کے تجربہ میں ایک 2 mm نصف قطر اور 3 g cm^{-3} کثافت کی ایک تیل کی بوند کو ایک برقی میدان $3.55 \times 10^5 \text{ V m}^{-1}$ کے اثر میں غیر محرک کیا گیا ہے۔ تیل کی بوند میں کتنے اضافی الیکٹران ہیں ؟

(لیجئے : $g = 9.81 \text{ m/s}^2$)

Options :

86435120251. 17.3×10^{10}

86435120252. 1.73×10^{10}

86435120253. 1.73×10^{12}

86435120254. 48.8×10^{11}

Question Number : 2 Question Id : 8643516752 Question Type : MCQ Option Shuffling : Yes Is

Question Mandatory : No

Correct Marks : 4 Wrong Marks : 1

A constant power delivering machine has towed a box, which was initially at rest, along a horizontal straight line. The distance moved by the box in time 't' is proportional to :

Options :

86435120255. $t^{3/2}$ 86435120256. $t^{1/2}$ 86435120257. $t^{2/3}$ 86435120258. t **Question Number : 2 Question Id : 8643516752 Question Type : MCQ Option Shuffling : Yes Is****Question Mandatory : No****Correct Marks : 4 Wrong Marks : 1**

ایک مستقل طاقت دینے والی ایک مشین نے ایک ڈبہ کو ایک خط مستقیم کے ہمراہ جو کہ ابتدا میں حالت سکون میں تھا، اٹھایا ہے۔ ڈبہ کے ذریعہ وقفہ t میں چلی گئی دوری مندرجہ ذیل میں سے کس کے تناسب ہوگی ؟

Options :86435120255. $t^{3/2}$ 86435120256. $t^{1/2}$ 86435120257. $t^{2/3}$ 86435120258. t **Question Number : 3 Question Id : 8643516753 Question Type : MCQ Option Shuffling : Yes Is****Question Mandatory : No****Correct Marks : 4 Wrong Marks : 1**

Four identical long solenoids A, B, C and D are connected to each other as shown in the figure. If the magnetic field at the center of A is 3 T, the field at the center of C would be : (Assume that the magnetic field is confined within the volume of respective solenoid).

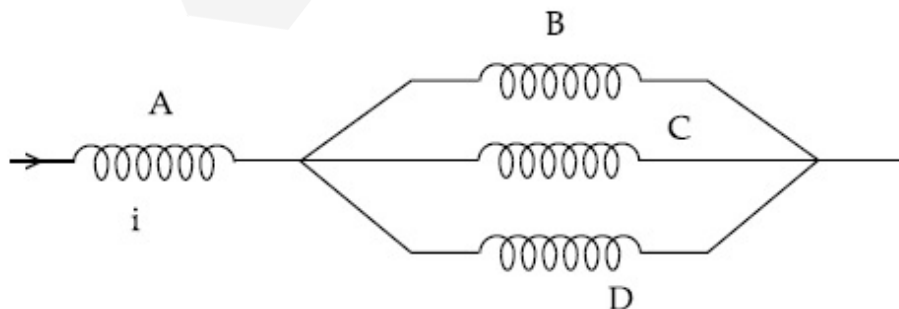
**Options :**

86435120259. 1 T

86435120260. 9 T

86435120261. 6 T

86435120262. 12 T

Question Number : 3 Question Id : 8643516753 Question Type : MCQ Option Shuffling : Yes Is Question Mandatory : No

Correct Marks : 4 Wrong Marks : 1

شکل میں دیئے گئے طرز پر چار یکساں سولی نائیڈ A, B, C اور D جوڑے گئے ہیں۔ اگر A کے مرکز پر مقناطیسی میدان 3 T ہے تو C کے مرکز پر مقناطیسی میدان کی قدر ہوگی :
(فرض کریں کہ مقناطیسی میدان ہر سولی نائیڈ کے حجم میں محدود ہے)

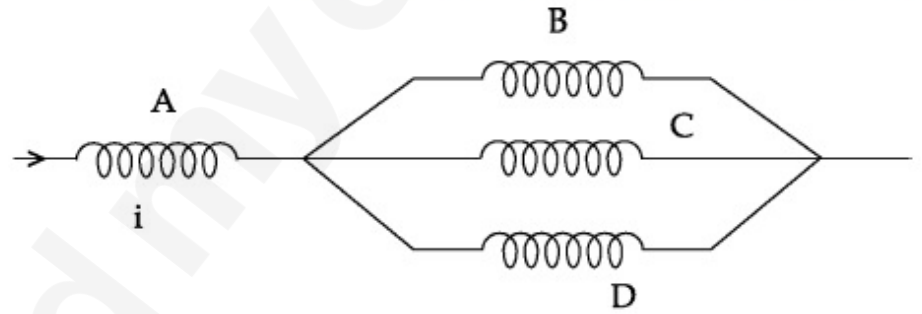

Options :

86435120259. 1 T

86435120260. 9 T

86435120261. 6 T

86435120262. 12 T

Question Number : 4 Question Id : 8643516754 Question Type : MCQ Option Shuffling : Yes Is Question Mandatory : No

Correct Marks : 4 Wrong Marks : 1

The P-V diagram of a diatomic ideal gas system going under cyclic process as shown in figure. The work done during an adiabatic process CD is (use $\gamma = 1.4$) :

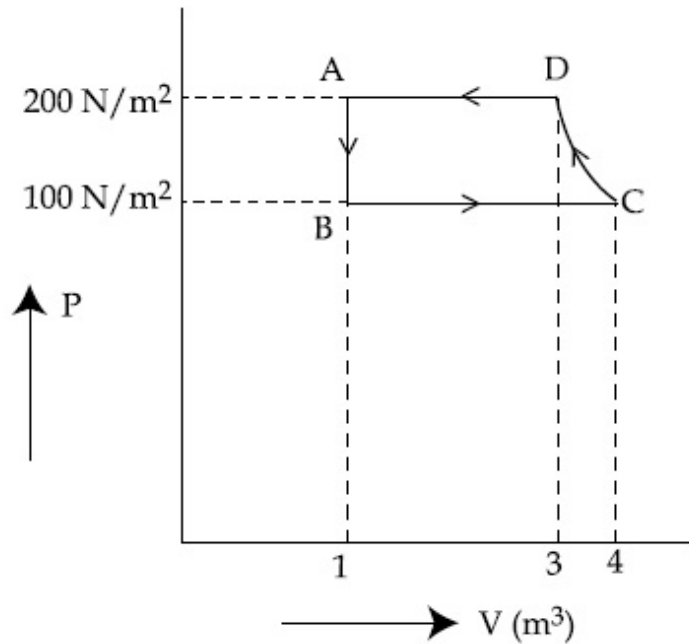

Options :

86435120263. 400 J
86435120264. -500 J
86435120265. 200 J
86435120266. -400 J

Question Number : 4 Question Id : 8643516754 Question Type : MCQ Option Shuffling : Yes Is

Question Mandatory : No

Correct Marks : 4 Wrong Marks : 1

دیے گئے P-V شکل کی طرز پر ایک دو جوہری مثالی گیس کو ایک دائروی عمل سے گزارا گیا ہے۔ حرانگزار عمل CD کے دوران کیا گیا کام ہوگا :

(استعمال کیجیے : $\gamma = 1.4$)

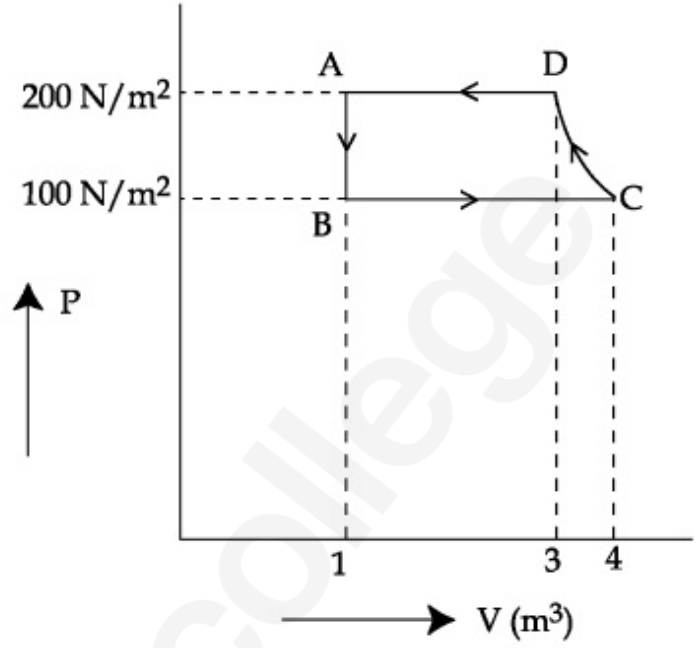

Options :

86435120263. 400 J

86435120264. -500 J

86435120265. 200 J

86435120266. -400 J

Question Number : 5 Question Id : 8643516755 Question Type : MCQ Option Shuffling : Yes Is

Question Mandatory : No

Correct Marks : 4 Wrong Marks : 1

The position, velocity and acceleration of a particle moving with a constant acceleration can be represented by :

Options :

86435120267.

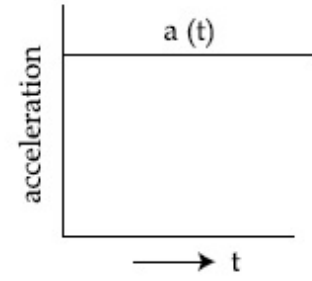
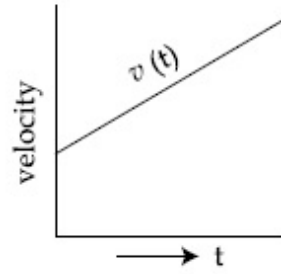
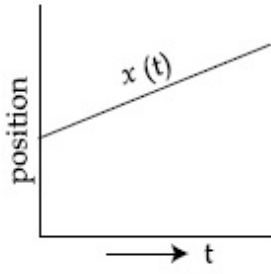

86435120268.

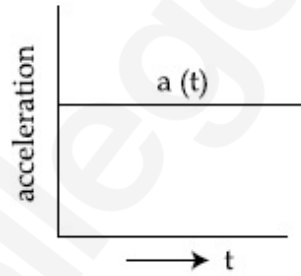
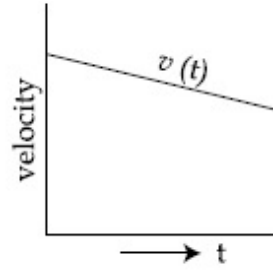
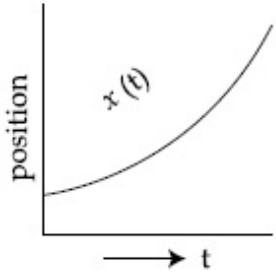

86435120269.

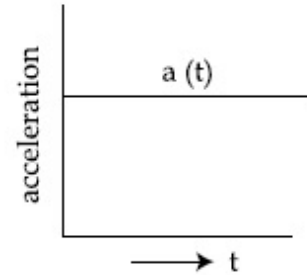
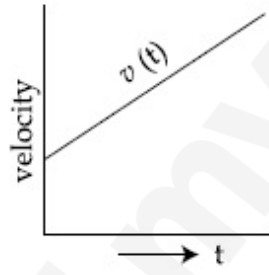
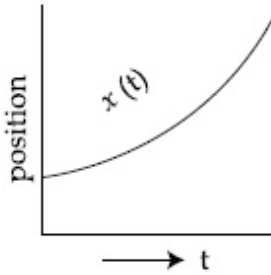

86435120270.

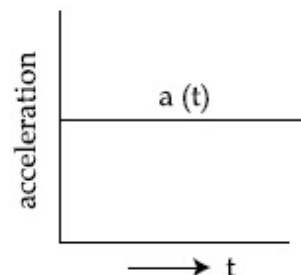
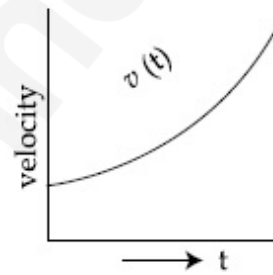
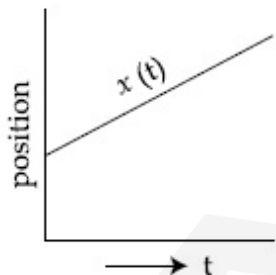

Question Number : 5 Question Id : 8643516755 Question Type : MCQ Option Shuffling : Yes Is Question Mandatory : No

Correct Marks : 4 Wrong Marks : 1

ایک مستقل اسراع کے ساتھ چلتے ہوئے جسم کے مقام، رفتار اور اسراع کو مندرجہ ذیل میں سے کس طرح ظاہر کیا جاسکتا ہے :

Options :

86435120267.

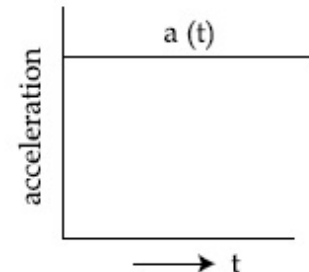
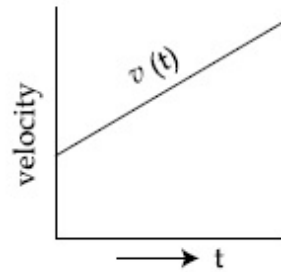
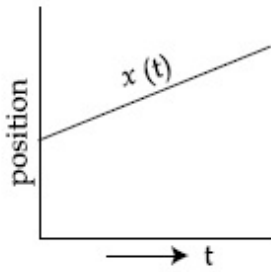

86435120268.

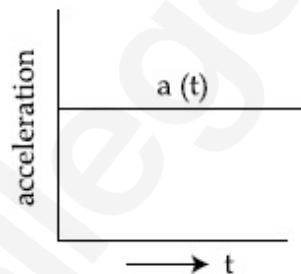
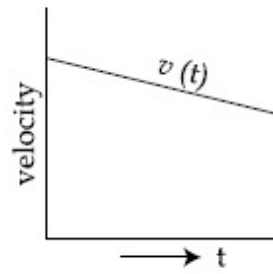
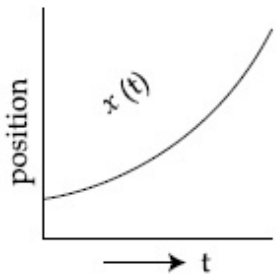

86435120269.

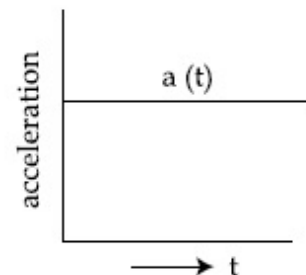
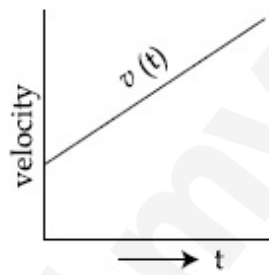
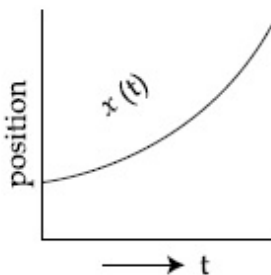

86435120270.

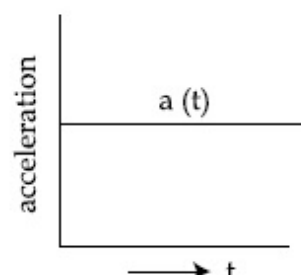
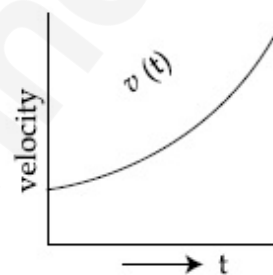
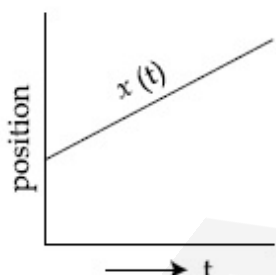

Question Number : 6 Question Id : 8643516756 Question Type : MCQ Option Shuffling : Yes Is Question Mandatory : No

Correct Marks : 4 Wrong Marks : 1

An AC source rated 220 V, 50 Hz is connected to a resistor. The time taken by the current to change from its maximum to the rms value is :

Options :

86435120271. 2.5 ms

86435120272. 25 ms

86435120273. 0.25 ms

86435120274. 2.5 s

Question Number : 6 Question Id : 8643516756 Question Type : MCQ Option Shuffling : Yes Is

Question Mandatory : No

Correct Marks : 4 Wrong Marks : 1

AC کے ایک 220 V, 50 Hz منبع کو ایک مزاحمت کے ساتھ جوڑا جاتا ہے۔ برقی رو کے ذریعہ اعظم قدر سے rms قدر تک تبدیل ہونے میں لگنے والا وقت ہوگا :

Options :

86435120271. 2.5 ms

86435120272. 25 ms

86435120273. 0.25 ms

86435120274. 2.5 s

Question Number : 7 Question Id : 8643516757 Question Type : MCQ Option Shuffling : Yes Is

Question Mandatory : No

Correct Marks : 4 Wrong Marks : 1

In Young's double slit arrangement, slits are separated by a gap of 0.5 mm, and the screen is placed at a distance of 0.5 m from them. The distance between the first and the third bright fringe formed when the slits are illuminated by a monochromatic light of 5890 Å is :

Options :

86435120275. 1178×10^{-12} m

86435120276. 5890×10^{-7} m

86435120277. 1178×10^{-9} m

86435120278. 1178×10^{-6} m

Question Number : 7 Question Id : 8643516757 Question Type : MCQ Option Shuffling : Yes Is

Question Mandatory : No

Correct Marks : 4 Wrong Marks : 1

ینگ کی دوہری جھری کی ترتیب میں، جھریاں ایک دوسرے سے 0.5 mm کے فاصلہ پر ہیں اور پردہ کو ان سے 0.5 m کی دوری پر رکھا گیا ہے۔ جب جھریوں کو 5890 \AA کی نور سے روشن کیا جاتا ہے تو پہلی اور تیسری روشن پٹی کے بیچ کا فاصلہ ہوگا:

Options :

86435120275. $1178 \times 10^{-12} \text{ m}$

86435120276. $5890 \times 10^{-7} \text{ m}$

86435120277. $1178 \times 10^{-9} \text{ m}$

86435120278. $1178 \times 10^{-6} \text{ m}$

Question Number : 8 Question Id : 8643516758 Question Type : MCQ Option Shuffling : Yes Is

Question Mandatory : No

Correct Marks : 4 Wrong Marks : 1

A particle is travelling 4 times as fast as an electron. Assuming the ratio of de-Broglie wavelength of a particle to that of electron is 2 : 1, the mass of the particle is :

Options :

86435120279. 8 times the mass of e^{-}

86435120280. $\frac{1}{16}$ times the mass of e^{-}

86435120281. 16 times the mass of e^{-}

86435120282. $\frac{1}{8}$ times the mass of e^{-}

Question Number : 8 Question Id : 8643516758 Question Type : MCQ Option Shuffling : Yes Is

Question Mandatory : No

Correct Marks : 4 Wrong Marks : 1

ایک جسم الیکٹران سے 4 گنا رفتار سے چلتا ہے۔ اگر اجسام کے ڈی بروگلی طول موج کی نسبت 2 : 1 ہو تو جسم کی کمیت :

Options :

86435120279. e^{-} کی قیمت کا 8 گنا

86435120280. e^{-} کی قیمت کا $\frac{1}{16}$ گنا

86435120281. e^{-} کی قیمت کا 16 گنا

86435120282. e^{-} کی قیمت کا $\frac{1}{8}$ گنا

Question Number : 9 Question Id : 8643516759 Question Type : MCQ Option Shuffling : Yes Is Question Mandatory : No

Correct Marks : 4 Wrong Marks : 1

The time period of a simple pendulum is given by $T = 2\pi\sqrt{\frac{l}{g}}$. The measured value of the

length of pendulum is 10 cm known to a 1 mm accuracy. The time for 200 oscillations of the pendulum is found to be 100 second using a clock of 1 s resolution. The percentage accuracy in the determination of 'g' using this pendulum is 'x'. The value of 'x' to the nearest integer is,

Options :

86435120283. 2%

86435120284. 3%

86435120285. 4%

86435120286. 5%

Question Number : 9 Question Id : 8643516759 Question Type : MCQ Option Shuffling : Yes Is Question Mandatory : No

Correct Marks : 4 Wrong Marks : 1

سادہ رقاص کا دور $T = 2\pi\sqrt{\frac{l}{g}}$ سے دیا جاتا ہے۔ دیے گئے رقاص کی لمبائی 1 mm صحت کے ساتھ 10 cm ہے اور 200 ابتراز کا وقت ایک 1 s تحلیل کی گھڑی سے 100 sec ناپا گیا۔ اس رقاص کے ذریعہ 'g' کے تعین کی فی صد صحت (accuracy) 'x' ہے تب قریب ترین مکمل عدد میں x کی قدر ہے :

Options :

86435120283. 2 %

86435120284. 3 %

86435120285. 4 %

86435120286. 5 %

Question Number : 10 Question Id : 8643516760 Question Type : MCQ Option Shuffling : Yes Is Question Mandatory : No

Correct Marks : 4 Wrong Marks : 1

Imagine that the electron in a hydrogen atom is replaced by a muon (μ). The mass of muon particle is 207 times that of an electron and charge is equal to the charge of an electron. The ionization potential of this hydrogen atom will be :

Options :

86435120287. 13.6 eV

86435120288. 27.2 eV

86435120289. 331.2 eV

86435120290. 2815.2 eV

Question Number : 10 Question Id : 8643516760 Question Type : MCQ Option Shuffling : Yes Is Question Mandatory : No

Correct Marks : 4 Wrong Marks : 1

تصور کیجیے کہ ہائیڈروجن جو ہر میں ایک الیکٹران کو ایک میوآن (μ) سے بدلا گیا ہے۔ میوآن کی کمیت الیکٹران کی کمیت کا 207 گنا اور میوآن کا برقی بار الیکٹران کے برقی بار کے مساوی ہے۔ اس ہائیڈروجن جو ہر آئن کاری مضمحل ہوگا :

Options :

86435120287. 13.6 eV

86435120288. 27.2 eV

86435120289. 331.2 eV

86435120290. 2815.2 eV

Question Number : 11 Question Id : 8643516761 Question Type : MCQ Option Shuffling : Yes Is

Question Mandatory : No

Correct Marks : 4 Wrong Marks : 1

A radioactive sample disintegrates via two independent decay processes having half lives

$T_{1/2}^{(1)}$ and $T_{1/2}^{(2)}$ respectively. The effective half-life, $T_{1/2}$ of the nuclei is :

Options :

$$T_{1/2} = \frac{T_{1/2}^{(1)} T_{1/2}^{(2)}}{T_{1/2}^{(1)} + T_{1/2}^{(2)}}$$

86435120291.

$$T_{1/2} = T_{1/2}^{(1)} + T_{1/2}^{(2)}$$

86435120292.

$$T_{1/2} = \frac{T_{1/2}^{(1)} + T_{1/2}^{(2)}}{T_{1/2}^{(1)} - T_{1/2}^{(2)}}$$

86435120293.

86435120294. None of the above

Question Number : 11 Question Id : 8643516761 Question Type : MCQ Option Shuffling : Yes Is

Question Mandatory : No

Correct Marks : 4 Wrong Marks : 1

ایک تابکار نمونہ دو غیر پابند تنزلی عمل کے ذریعہ ذوال پذیر ہوتا ہے جن کی نصف زندگی بالترتیب $T_{1/2}^{(1)}$ اور $T_{1/2}^{(2)}$ ہیں۔ جب نمونہ کی پراثر نصف زندگی

ہوگی : $T_{1/2}$

Options :

$$T_{1/2} = \frac{T_{1/2}^{(1)} T_{1/2}^{(2)}}{T_{1/2}^{(1)} + T_{1/2}^{(2)}}$$

86435120291.

$$T_{1/2} = T_{1/2}^{(1)} + T_{1/2}^{(2)}$$

86435120292.

$$T_{1/2} = \frac{T_{1/2}^{(1)} + T_{1/2}^{(2)}}{T_{1/2}^{(1)} - T_{1/2}^{(2)}}$$

86435120293.

86435120294. اوپر میں سے کوئی نہیں

Question Number : 12 Question Id : 8643516762 Question Type : MCQ Option Shuffling : Yes Is Question Mandatory : No

Correct Marks : 4 Wrong Marks : 1

A loop of flexible wire of irregular shape carrying current is placed in an external magnetic field. Identify the effect of the field on the wire.

Options :

86435120295. shape of the loop remains unchanged

86435120296. loop assumes circular shape with its plane normal to the field

86435120297. loop assumes circular shape with its plane parallel to the field

86435120298. wire gets stretched to become straight

Question Number : 12 Question Id : 8643516762 Question Type : MCQ Option Shuffling : Yes Is Question Mandatory : No

Correct Marks : 4 Wrong Marks : 1

غیر مرتب جسامت کے برقی روشدہ لچیلے تار کے ایک چھلے کو ایک باہری مقناطیسی میدان میں رکھا گیا ہے۔ مقناطیسی میدان کے ذریعہ تار پر ہونے والے اثر کی شناخت کیجیے :

Options :

86435120295. چھلے کی جسامت تبدیل نہیں ہوگی۔

86435120296. چھلہ ایک دائری شکل لیتا ہے جس کا مستوی میدان کے عمودی ہو۔

86435120297. چھلہ ایک دائری شکل لیتا ہے جس کا مستوی میدان کے متوازی ہو۔

86435120298. تار کھینچ کر سیدھا ہو جاتا ہے۔

Question Number : 13 Question Id : 8643516763 Question Type : MCQ Option Shuffling : Yes Is Question Mandatory : No

Correct Marks : 4 Wrong Marks : 1

In the experiment of Ohm's law, a potential difference of 5.0 V is applied across the end of a conductor of length 10.0 cm and diameter of 5.00 mm. The measured current in the conductor is 2.00 A. The maximum permissible percentage error in the resistivity of the conductor is :

Options :

86435120299. 3.9

86435120300. 7.5

86435120301. 8.4

86435120302. 3.0

Question Number : 13 Question Id : 8643516763 Question Type : MCQ Option Shuffling : Yes Is Question Mandatory : No

Correct Marks : 4 Wrong Marks : 1

اوم کے قانون کے تجربے میں ایک 10.0 cm لمبائی اور 5.00 mm قطر کے ایک موصل کے کناروں کے بیچ ایک مضمر فرق 5.0 V لگایا گیا ہے۔ موصل میں ناپا گیا برقی رو 2.00 A ہے۔ موصل کی مزاحمت میں اعظم جائز فی صد سہو ہوگی :

Options :

86435120299. 3.9

86435120300. 7.5

86435120301. 8.4

86435120302. 3.0

Question Number : 14 Question Id : 8643516764 Question Type : MCQ Option Shuffling : Yes Is

Question Mandatory : No

Correct Marks : 4 Wrong Marks : 1

The time period of a satellite in a circular orbit of radius R is T . The period of another satellite in a circular orbit of radius $9R$ is :

Options :

86435120303. 3 T

86435120304. 9 T

86435120305. 27 T

86435120306. 12 T

Question Number : 14 Question Id : 8643516764 Question Type : MCQ Option Shuffling : Yes Is

Question Mandatory : No

Correct Marks : 4 Wrong Marks : 1

ایک سیارہ جو کہ R نصف قطر کے ایک دائروی مدار میں گردش کر رہا ہے، کا دور T ہے۔ ایک دوسرے سیارہ کے دائروی مدار کا نصف قطر $9R$ ہے۔ اس کا دور کیا ہوگا ؟

Options :

86435120303. 3 T

86435120304. 9 T

86435120305. 27 T

86435120306. 12 T

Question Number : 15 Question Id : 8643516765 Question Type : MCQ Option Shuffling : Yes Is

Question Mandatory : No

Correct Marks : 4 Wrong Marks : 1

In a series LCR resonance circuit, if we change the resistance only, from a lower to higher value :

Options :

86435120307. The resonance frequency will increase
86435120308. The bandwidth of resonance circuit will increase
86435120309. The quality factor will increase
86435120310. The quality factor and the resonance frequency will remain constant

Question Number : 15 Question Id : 8643516765 Question Type : MCQ Option Shuffling : Yes Is Question Mandatory : No

Correct Marks : 4 Wrong Marks : 1

ایک سلسلہ وار LCR گمگ سرکٹ میں اگر ہم صرف مزاحمت کو ایک نچلی قدر سے اونچی قدر میں تبدیل کرتے ہیں تو :

Options :

86435120307. گمگ رعدد بڑھے گا۔
86435120308. گمگ سرکٹ کی تعدد کی پٹی کی چوڑائی بڑھے گی۔
86435120309. کیفیت جڑ ضربی بڑھے گا۔
86435120310. کیفیت جڑ ضربی اور گمگ رعدد دونوں مستقل رہیں گے۔

Question Number : 16 Question Id : 8643516766 Question Type : MCQ Option Shuffling : Yes Is Question Mandatory : No

Correct Marks : 4 Wrong Marks : 1

Your friend is having eye sight problem. She is not able to see clearly a distant uniform window mesh and it appears to her as non-uniform and distorted. The doctor diagnosed the problem as :

Options :

86435120311. Myopia and hypermetropia
86435120312. Presbyopia with Astigmatism

86435120313. Astigmatism

86435120314. Myopia with Astigmatism

Question Number : 16 Question Id : 8643516766 Question Type : MCQ Option Shuffling : Yes Is Question Mandatory : No

Correct Marks : 4 Wrong Marks : 1

آپ کے دوست کو آنکھوں کی نظر کا مسئلہ ہے۔ وہ یکساں کھڑکی کی جالی کو نہ صرف صاف دیکھنے سے قاصر ہے بلکہ اس کو جالی غیر یکساں اور غیر سالم دکھائی دیتی ہے۔ ڈاکٹر نے اس مسئلہ کو کیا تجویز کیا :

Options :

86435120311. (Myopia and hypermetropia) مایو پیا اور ہائپر میٹروپیا

86435120312. (Presbyopia with Astigmatism) ایسٹگمیٹزم کے ساتھ پریسبایو پیا

86435120313. (Astigmatism) ایسٹگمیٹزم

86435120314. (Myopia with Astigmatism) مایو پیا کے ساتھ ایسٹگمیٹزم

Question Number : 17 Question Id : 8643516767 Question Type : MCQ Option Shuffling : Yes Is Question Mandatory : No

Correct Marks : 4 Wrong Marks : 1

What will be the average value of energy along one degree of freedom for an ideal gas in thermal equilibrium at a temperature T ? (k_B is Boltzmann constant)

Options :

86435120315. $k_B T$

86435120316. $\frac{1}{2} k_B T$

86435120317. $\frac{3}{2} k_B T$

$$\frac{2}{3} k_B T$$

86435120318.

Question Number : 17 Question Id : 8643516767 Question Type : MCQ Option Shuffling : Yes Is Question Mandatory : No

Correct Marks : 4 Wrong Marks : 1

درجہ حرارت T پر حرارتی توازن میں ایک مثالی گیس کی ایک ڈگری آف فریڈیم کے ہمراہ اوسط توانائی کیا ہوگی ؟
(k_B بولٹز مین مستقلہ ہے)

Options :

$$k_B T$$

86435120315.

$$\frac{1}{2} k_B T$$

86435120316.

$$\frac{3}{2} k_B T$$

86435120317.

$$\frac{2}{3} k_B T$$

86435120318.

Question Number : 18 Question Id : 8643516768 Question Type : MCQ Option Shuffling : Yes Is Question Mandatory : No

Correct Marks : 4 Wrong Marks : 1

Match List - I with List - II.

List - I

- (a) 10 km height over earth's surface
- (b) 70 km height over earth's surface
- (c) 180 km height over earth's surface
- (d) 270 km height over earth's surface

List - II

- (i) Thermosphere
- (ii) Mesosphere
- (iii) Stratosphere
- (iv) Troposphere

Options :

$$(a)-(iv), (b)-(iii), (c)-(ii), (d)-(i)$$

86435120319.

$$(a)-(iii), (b)-(ii), (c)-(i), (d)-(iv)$$

86435120320.

86435120321. (a)-(ii), (b)-(i), (c)-(iv), (d)-(iii)

86435120322. (a)-(i), (b)-(iv), (c)-(iii), (d)-(ii)

Question Number : 18 Question Id : 8643516768 Question Type : MCQ Option Shuffling : Yes Is Question Mandatory : No

Correct Marks : 4 Wrong Marks : 1

فہرست - I کو فہرست - II سے ملائیے :

فہرست - II		فہرست - I	
حرارتی کرہ	(i)	زمین کی سطح سے 10 km اوپر	(a)
درمیانی کرہ	(ii)	زمین کی سطح سے 70 km اوپر	(b)
قائمی کرہ	(iii)	زمین کی سطح سے 180 km اوپر	(c)
متغیرہ کرہ	(iv)	زمین کی سطح سے 270 km اوپر	(d)

Options :

86435120319. (a)-(iv), (b)-(iii), (c)-(ii), (d)-(i)

86435120320. (a)-(iii), (b)-(ii), (c)-(i), (d)-(iv)

86435120321. (a)-(ii), (b)-(i), (c)-(iv), (d)-(iii)

86435120322. (a)-(i), (b)-(iv), (c)-(iii), (d)-(ii)

Question Number : 19 Question Id : 8643516769 Question Type : MCQ Option Shuffling : Yes Is Question Mandatory : No

Correct Marks : 4 Wrong Marks : 1

A plane electromagnetic wave of frequency 100 MHz is travelling in vacuum along the x-direction. At a particular point in space and time, $\vec{B} = 2.0 \times 10^{-8} \hat{k}$ T. (where, \hat{k} is unit vector along z-direction) What is \vec{E} at this point ?

(speed of light $c = 3 \times 10^8$ m/s)

Options :

86435120323. $0.6 \hat{j}$ V/m

86435120324. $6.0 \hat{j} \text{ V/m}$

86435120325. $6.0 \hat{k} \text{ V/m}$

86435120326. $0.6 \hat{k} \text{ V/m}$

Question Number : 19 Question Id : 8643516769 Question Type : MCQ Option Shuffling : Yes Is Question Mandatory : No

Correct Marks : 4 Wrong Marks : 1

ایک مستوی برقی مقناطیسی لہر جس کی تعدد 100 MHz ہے، خلا میں x محور میں سفر کر رہی ہے۔ مکان وزماں کے ایک خاص نقطہ پر $\vec{B} = 2.0 \times 10^{-8} \hat{k} \text{ T}$ ہے۔ (جہاں \hat{k} z سمت میں اکائی سمتیہ ہے) اس نقطہ پر \vec{E} کیا ہوگی ؟
(نور کی چال : $c = 3 \times 10^8 \text{ m/s}$)

Options :

86435120323. $0.6 \hat{j} \text{ V/m}$

86435120324. $6.0 \hat{j} \text{ V/m}$

86435120325. $6.0 \hat{k} \text{ V/m}$

86435120326. $0.6 \hat{k} \text{ V/m}$

Question Number : 20 Question Id : 8643516770 Question Type : MCQ Option Shuffling : Yes Is Question Mandatory : No

Correct Marks : 4 Wrong Marks : 1

A thin circular ring of mass M and radius r is rotating about its axis with an angular speed ω . Two particles having mass m each are now attached at diametrically opposite points. The angular speed of the ring will become :

Options :

86435120327. $\omega \frac{M}{M + m}$

86435120328. $\omega \frac{M}{M + 2m}$

86435120329. $\omega \frac{M - 2m}{M + 2m}$

86435120330. $\omega \frac{M + 2m}{M}$

Question Number : 20 Question Id : 8643516770 Question Type : MCQ Option Shuffling : Yes Is
Question Mandatory : No
Correct Marks : 4 Wrong Marks : 1

کیت m اور نصف قطر r کا ایک مہین دائروی چھلہ اپنے محور کے اطراف زاویائی چال ω کے ساتھ حالت گردش میں ہے۔ دو جسم جن میں سے ہر ایک کی کیت m ہے، قطری طور پر مخالف نقاط پر جوڑ دیے جاتے ہیں۔ چھلہ کی زاویائی چال اب ہوگی :

Options :

86435120327. $\omega \frac{M}{M + m}$

86435120328. $\omega \frac{M}{M + 2m}$

86435120329. $\omega \frac{M - 2m}{M + 2m}$

86435120330. $\omega \frac{M + 2m}{M}$

Physics Section B

Section Id :	864351452
Section Number :	2
Section type :	Online
Mandatory or Optional :	Mandatory
Number of Questions :	10
Number of Questions to be attempted :	5
Section Marks :	20
Mark As Answered Required? :	Yes

Sub-Section Number : 1
Sub-Section Id : 864351452
Question Shuffling Allowed : Yes

Question Number : 21 Question Id : 8643516771 Question Type : SA
Correct Marks : 4 Wrong Marks : 0

An npn transistor operates as a common emitter amplifier with a power gain of 10^6 . The input circuit resistance is 100Ω and the output load resistance is $10 \text{ k}\Omega$. The common emitter current gain ' β ' will be _____. (Round off to the Nearest Integer)

Response Type : Numeric
Evaluation Required For SA : Yes
Show Word Count : Yes
Answers Type : Equal
Text Areas : PlainText
Possible Answers :
 100

Question Number : 21 Question Id : 8643516771 Question Type : SA
Correct Marks : 4 Wrong Marks : 0

ایک npn ٹرانسسٹر 10^6 طاقت کے اضافہ والے مشترکہ مخرج افزائش کار کے طور پر کام کرتا ہے۔ ان پٹ سرکٹ مزاحمت 100Ω اور آؤٹ پٹ سرکٹ مزاحمت $10 \text{ k}\Omega$ ہے۔ مشترکہ مخرج برقی رو کا اضافہ ' β ' _____ ہوگا۔ (قریب ترین مکمل عدد میں جواب دیں)

Response Type : Numeric
Evaluation Required For SA : Yes
Show Word Count : Yes
Answers Type : Equal
Text Areas : PlainText
Possible Answers :
 100

Question Number : 22 Question Id : 8643516772 Question Type : SA
Correct Marks : 4 Wrong Marks : 0

A ball of mass 10 kg moving with a velocity $10\sqrt{3}$ m/s along the x -axis, hits another ball of mass 20 kg which is at rest. After the collision, first ball comes to rest while the second ball disintegrates into two equal pieces. One piece starts moving along y -axis with a speed of 10 m/s. The second piece starts moving at an angle of 30° with respect to the x -axis.

The velocity of the ball moving at 30° with x -axis is x m/s.

The configuration of pieces after collision is shown in the figure below.

The value of x to the nearest integer is _____.

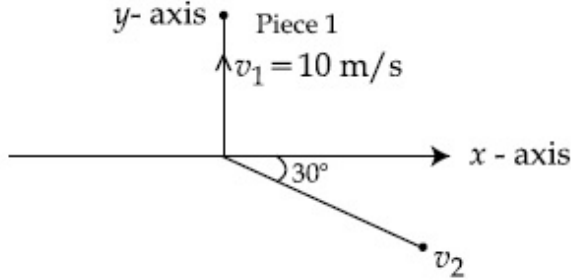

Response Type : Numeric

Evaluation Required For SA : Yes

Show Word Count : Yes

Answers Type : Equal

Text Areas : PlainText

Possible Answers :

100

Question Number : 22 **Question Id :** 8643516772 **Question Type :** SA

Correct Marks : 4 **Wrong Marks :** 0

10 kg کمیت کی ایک بال جو کہ $10\sqrt{3}$ m/s کی رفتار سے x -محور کے ہمراہ حرکت کر رہی ہے۔ 20 kg کمیت کی ایک دوسری بال کو جو کہ حالت سکون میں ہے، سے ٹکراتی ہے۔ تصادم کے بعد پہلی بال حالت سکون میں آتی ہے جبکہ دوسری بال دو ٹکڑوں میں ٹوٹ جاتی ہے۔ ایک ٹکڑا y -محور کے ہمراہ 10 m/s کی چال سے حرکت کرتا ہے جبکہ دوسرا ٹکڑا x -محور سے 30° کے زاویہ پر x m/s کی رفتار سے حرکت کرتا ہے۔ تب x کی قدر قریب ترین مکمل عدد میں ہوگی۔

ٹکڑوں کی ترتیب دی گئی شکل میں دکھائی گئی ہے۔

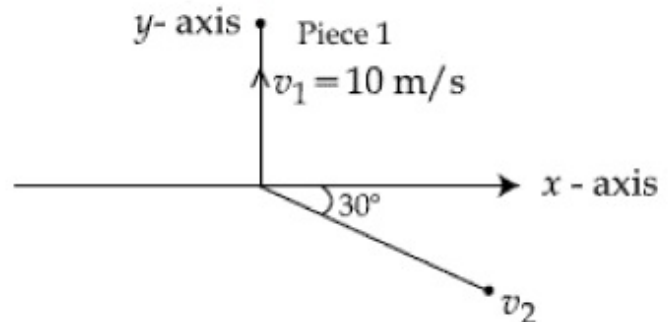

Response Type : Numeric

Evaluation Required For SA : Yes

Show Word Count : Yes

Answers Type : Equal

Text Areas : PlainText

Possible Answers :

100

Question Number : 23 Question Id : 8643516773 Question Type : SA

Correct Marks : 4 Wrong Marks : 0

The voltage across the $10\ \Omega$ resistor in the given circuit is x volt.

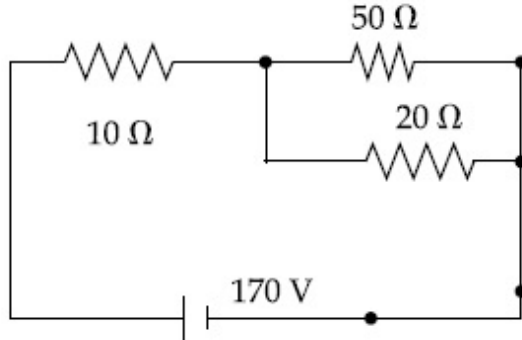

The value of ' x ' to the nearest integer is _____.

Response Type : Numeric

Evaluation Required For SA : Yes

Show Word Count : Yes

Answers Type : Equal

Text Areas : PlainText

Possible Answers :

100

Question Number : 23 Question Id : 8643516773 Question Type : SA

Correct Marks : 4 Wrong Marks : 0

دیے گئے سرکٹ میں مزاحمت $10\ \Omega$ کے سروں کے بیچ میں دو لٹیج $x\ V$ ہے۔

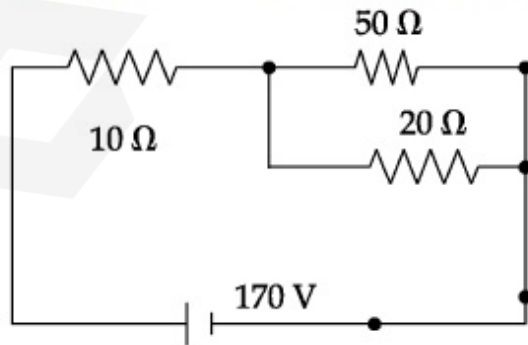

قریب ترین مکمل عدد میں ' x ' کی قدر _____ ہے۔

Response Type : Numeric

Evaluation Required For SA : Yes

Show Word Count : Yes

Answers Type : Equal

Text Areas : PlainText

Possible Answers :

100

Question Number : 24 Question Id : 8643516774 Question Type : SA

Correct Marks : 4 Wrong Marks : 0

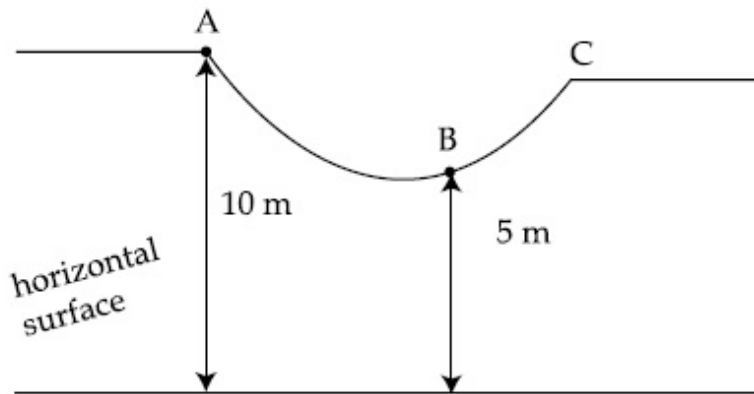

As shown in the figure, a particle of mass 10 kg is placed at a point A. When the particle is slightly displaced to its right, it starts moving and reaches the point B. The speed of the particle at B is x m/s.

(Take $g = 10 \text{ m/s}^2$)

The value of ' x ' to the nearest integer is _____.

Response Type : Numeric

Evaluation Required For SA : Yes

Show Word Count : Yes

Answers Type : Equal

Text Areas : PlainText

Possible Answers :

100

Question Number : 24 Question Id : 8643516774 Question Type : SA

Correct Marks : 4 Wrong Marks : 0

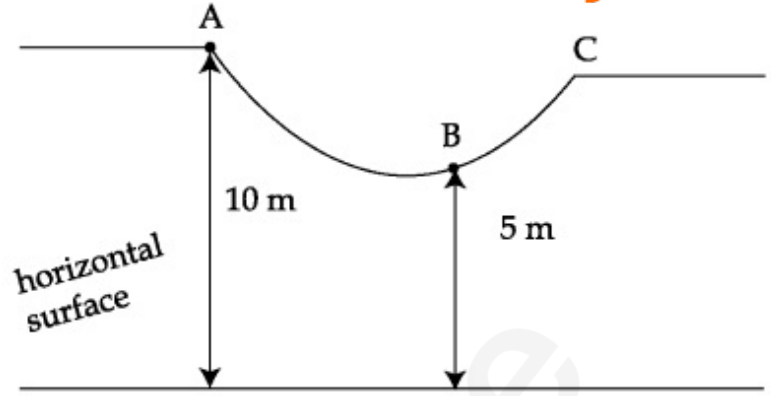

شکل کے حساب سے ایک 10 kg کمیت کا جسم نقطہ A پر رکھا ہے۔ جب جسم کو اس کے دائیں جانب ہلکا سا ہٹایا جاتا ہے تو وہ حرکت کرنا شروع کرتا ہے اور نقطہ B پر پہنچ جاتا ہے۔ جسم کی نقطہ B پر رفتار x m/s ہے۔
(لیجیے : $g = 10 \text{ m/s}^2$)
قریب ترین مکمل عدد میں x کی قدر _____ ہوگی۔

Response Type : Numeric

Evaluation Required For SA : Yes

Show Word Count : Yes

Answers Type : Equal

Text Areas : PlainText

Possible Answers :

100

Question Number : 25 **Question Id :** 8643516775 **Question Type :** SA

Correct Marks : 4 **Wrong Marks :** 0

A particle performs simple harmonic motion with a period of 2 second. The time taken by the particle to cover a displacement equal to half of its amplitude from the mean position is

$$\frac{1}{a} \text{ s.}$$

The value of 'a' to the nearest integer is _____.

Response Type : Numeric

Evaluation Required For SA : Yes

Show Word Count : Yes

Answers Type : Equal

Text Areas : PlainText

Possible Answers :

100

Question Number : 25 **Question Id :** 8643516775 **Question Type :** SA

Correct Marks : 4 **Wrong Marks :** 0

ایک جسم 2 sec کے دور کے ساتھ سادہ ہارمونی حرکت کرتا ہے۔ اس جسم کے ذریعہ اپنی وسعت سے آدھی دوری پر اپنی درمیانہ مقام سے پہنچنے میں $\frac{1}{a}$ s کا وقت لگتا ہے۔ قریب ترین مکمل عدد میں 'a' کی قدر _____ ہوگی۔

Response Type : Numeric

Evaluation Required For SA : Yes

Show Word Count : Yes

Answers Type : Equal

Text Areas : PlainText

Possible Answers :

100

Question Number : 26 **Question Id :** 8643516776 **Question Type :** SA

Correct Marks : 4 **Wrong Marks :** 0

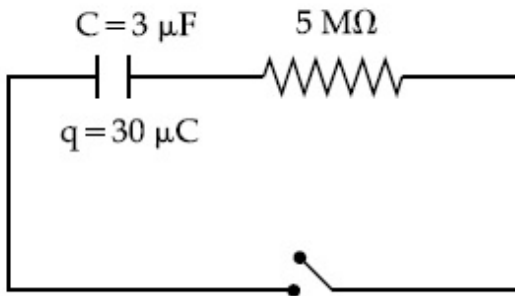

The circuit shown in the figure consists of a charged capacitor of capacity $3 \mu\text{F}$ and a charge of $30 \mu\text{C}$. At time $t=0$, when the key is closed, the value of current flowing through the $5 \text{ M}\Omega$ resistor is ' x ' μA .

The value of ' x ' to the nearest integer is _____.

Response Type : Numeric

Evaluation Required For SA : Yes

Show Word Count : Yes

Answers Type : Equal

Text Areas : PlainText

Possible Answers :

100

Question Number : 26 **Question Id :** 8643516776 **Question Type :** SA

Correct Marks : 4 **Wrong Marks :** 0

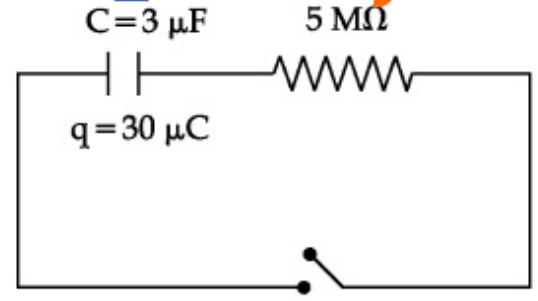

شکل میں دیے گئے سرکٹ میں صلاحیت $3\mu\text{F}$ کا ایک برقی ہوا ملٹھ جس پر برقی بار $30\mu\text{C}$ ہے، لگا ہے۔ وقفہ $t=0$ پر جب کنجی کو بند کیا جاتا ہے تو مزاحمت $5\text{M}\Omega$ میں بہنے والی برقی رو کی قدر $x\mu\text{A}$ ہوتی ہے۔
تب قریب ترین مکمل عدد میں x کی قدر _____ ہوگی۔

Response Type : Numeric

Evaluation Required For SA : Yes

Show Word Count : Yes

Answers Type : Equal

Text Areas : PlainText

Possible Answers :

100

Question Number : 27 **Question Id :** 8643516777 **Question Type :** SA

Correct Marks : 4 **Wrong Marks :** 0

A person is swimming with a speed of 10 m/s at an angle of 120° with the flow and reaches to a point directly opposite on the other side of the river. The speed of the flow is ' x ' m/s .

The value of ' x ' to the nearest integer is _____.

Response Type : Numeric

Evaluation Required For SA : Yes

Show Word Count : Yes

Answers Type : Equal

Text Areas : PlainText

Possible Answers :

100

Question Number : 27 **Question Id :** 8643516777 **Question Type :** SA

Correct Marks : 4 **Wrong Marks :** 0

ایک شخص بہاؤ کی سمت سے 120° کے زاویہ پر 10 m/s کی چال سے تیر رہا ہے۔ وہ دریا کے دوسرے کنارے پر ٹھیک سامنے والے نقطہ پر پہنچتا ہے۔ بہاؤ کی چال $x\text{ m/s}$ ہے۔ تب قریب ترین مکمل عدد میں x کی قدر _____ ہوگی۔

Response Type : Numeric

Evaluation Required For SA : Yes

Show Word Count : Yes

Answers Type : Equal

Text Areas : PlainText

Possible Answers :

100

Question Number : 28 Question Id : 8643516778 Question Type : SA

Correct Marks : 4 Wrong Marks : 0

Two separate wires A and B are stretched by 2 mm and 4 mm respectively, when they are subjected to a force of 2 N. Assume that both the wires are made up of same material and the radius of wire B is 4 times that of the radius of wire A. The length of the wires A and B

are in the ratio of a : b. Then $\frac{a}{b}$ can be expressed as $\frac{1}{x}$ where x is _____.

Response Type : Numeric

Evaluation Required For SA : Yes

Show Word Count : Yes

Answers Type : Equal

Text Areas : PlainText

Possible Answers :

100

Question Number : 28 Question Id : 8643516778 Question Type : SA

Correct Marks : 4 Wrong Marks : 0

دو الگ الگ تار A اور B ایک قوت 2N لگانے پر بالترتیب 2 mm اور 4 mm تک کھینچتے ہیں۔ فرض کیجیے کہ دونوں تار مساوی مادہ کے بنے ہوں اور تار B کی نصف قطر تار A کے نصف قطر سے 4 گنی ہو تب تار A اور B کے لمبائیوں کی نسبت a : b ہوتی ہے۔ تب $\frac{a}{b}$ کو $\frac{1}{x}$ سے ظاہر کیا جاتا ہے جہاں x کی قدر _____ ہے۔

Response Type : Numeric

Evaluation Required For SA : Yes

Show Word Count : Yes

Answers Type : Equal

Text Areas : PlainText

Possible Answers :

100

Question Number : 29 Question Id : 8643516779 Question Type : SA

Correct Marks : 4 Wrong Marks : 0

A parallel plate capacitor has plate area 100 m^2 and plate separation of 10 m . The space between the plates is filled up to a thickness 5 m with a material of dielectric constant of 10 . The resultant capacitance of the system is ' x ' pF.

The value of $\epsilon_0 = 8.85 \times 10^{-12} \text{ F.m}^{-1}$

The value of ' x ' to the nearest integer is _____.

Response Type : Numeric

Evaluation Required For SA : Yes

Show Word Count : Yes

Answers Type : Equal

Text Areas : PlainText

Possible Answers :

100

Question Number : 29 **Question Id :** 8643516779 **Question Type :** SA

Correct Marks : 4 **Wrong Marks :** 0

ایک متوازی چادر مکثہ کی چادر کا رقبہ 100 m^2 اور چادروں کے بیچ کا فاصلہ 10 m ہے۔ چادروں کے بیچ کی جگہ کو 5 m موٹائی کے 10 حرنا گزار مستقلہ والے ایک برق ناگزار سے بھرا جاتا ہے۔ تب نظام کی محاصل مزاحمت ' x ' pF ہے۔
 x کی قریب ترین مکمل عدد میں قدر _____ ہوگی جبکہ $\epsilon_0 = 8.85 \times 10^{-12} \text{ F. m}^{-1}$

Response Type : Numeric

Evaluation Required For SA : Yes

Show Word Count : Yes

Answers Type : Equal

Text Areas : PlainText

Possible Answers :

100

Question Number : 30 **Question Id :** 8643516780 **Question Type :** SA

Correct Marks : 4 **Wrong Marks :** 0

A bullet of mass 0.1 kg is fired on a wooden block to pierce through it, but it stops after moving a distance of 50 cm into it. If the velocity of bullet before hitting the wood is 10 m/s and it slows down with uniform deceleration, then the magnitude of effective retarding force on the bullet is ' x ' N.

The value of ' x ' to the nearest integer is _____.

Response Type : Numeric

Evaluation Required For SA : Yes

Show Word Count : Yes

Answers Type : Equal

Text Areas : PlainText

Possible Answers :

100

Question Number : 30 Question Id : 8643516780 Question Type : SA

Correct Marks : 4 Wrong Marks : 0

ایک 0.1 kg کمیت کی ایک گولی کو ایک لکڑی کے کندے میں داغا جاتا ہے۔ تو وہ اس میں دھنسن جاتی ہے۔ اور 50 cm اندر جا کر رکتی ہے۔ اگر لکڑی کو ٹکرانے سے پہلے گولی کی رفتار 10 m/s ہو اور وہ یکساں اسراع کے ساتھ مندی ہوتی ہے تب مزاحمتی قوت 'x' N ہوتی ہے۔ تب x کی قریب ترین مکمل عدد میں قدر _____ ہوگی۔

Response Type : Numeric

Evaluation Required For SA : Yes

Show Word Count : Yes

Answers Type : Equal

Text Areas : PlainText

Possible Answers :

100

Chemistry Section A

Section Id :	864351453
Section Number :	3
Section type :	Online
Mandatory or Optional :	Mandatory
Number of Questions :	20
Number of Questions to be attempted :	20
Section Marks :	80
Mark As Answered Required? :	Yes
Sub-Section Number :	1
Sub-Section Id :	864351453
Question Shuffling Allowed :	Yes

Question Number : 31 Question Id : 8643516781 Question Type : MCQ Option Shuffling : Yes Is

Question Mandatory : No

Correct Marks : 4 Wrong Marks : 1

In a binary compound, atoms of element A form a hcp structure and those of element M occupy 2/3 of the tetrahedral voids of the hcp structure. The formula of the binary compound is :

Options :

86435120341. M_2A_3

86435120342. M_4A_3 86435120343. MA_3 86435120344. M_4A

Question Number : 31 Question Id : 8643516781 Question Type : MCQ Option Shuffling : Yes Is
Question Mandatory : No

Correct Marks : 4 Wrong Marks : 1

دو عنصری مرکب میں عنصر A کے جوہر hcp بناوٹ میں ہیں جبکہ عنصر M کے جوہر hcp بناوٹ کے ”ٹیٹراہیڈرل وائڈ“ کے $2/3$ حصہ میں
میں سکونت کرتے ہیں۔ تو دو عنصری مرکب کا ضابطہ کیا ہوگا:

Options :

86435120341. M_2A_3 86435120342. M_4A_3 86435120343. MA_3 86435120344. M_4A

Question Number : 32 Question Id : 8643516782 Question Type : MCQ Option Shuffling : Yes Is
Question Mandatory : No

Correct Marks : 4 Wrong Marks : 1

A certain orbital has no angular nodes and two radial nodes. The orbital is :

Options :

86435120345. $2s$ 86435120346. $2p$ 86435120347. $3s$ 86435120348. $3p$

Question Number : 32 Question Id : 8643516782 Question Type : MCQ Option Shuffling : Yes Is
Question Mandatory : No

Correct Marks : 4 Wrong Marks : 1

ایک آرٹھل میں کوئی ”اینگولرنوڈ“ نہیں ہے۔ لیکن دو ”ریڈیل نوڈ“ ہے۔ آرٹھل کیا ہوگا۔

Options :

86435120345. 2s

86435120346. 2p

86435120347. 3s

86435120348. 3p

Question Number : 33 Question Id : 8643516783 Question Type : MCQ Option Shuffling : Yes Is Question Mandatory : No

Correct Marks : 4 Wrong Marks : 1

Match List - I with List - II :

List - I (Process)	List - II (Catalyst)
(a) Deacon's process	(i) ZSM-5
(b) Contact process	(ii) CuCl_2
(c) Cracking of hydrocarbons	(iii) Particles 'Ni'
(d) Hydrogenation of vegetable oils	(iv) V_2O_5

Choose the most appropriate answer from the options given below :

Options :

86435120349. (a)-(i), (b)-(iii), (c)-(ii), (d)-(iv)

86435120350. (a)-(iv), (b)-(ii), (c)-(i), (d)-(iii)

86435120351. (a)-(iii), (b)-(i), (c)-(iv), (d)-(ii)

86435120352. (a)-(ii), (b)-(iv), (c)-(i), (d)-(iii)

Question Number : 33 Question Id : 8643516783 Question Type : MCQ Option Shuffling : Yes Is Question Mandatory : No

Correct Marks : 4 Wrong Marks : 1

فہرست-I کو فہرست-II سے ملائیں۔

فہرست-II	فہرست-I
کٹالسٹ	عمل
ZSM-5 (i)	ڈیکن عمل (a)
CuCl ₂ (ii)	کنڈیکٹ عمل (b)
'Ni' - پارٹیکلز (iii)	ہائیڈروکاربن کی کریکنگ (c)
V ₂ O ₅ (iv)	بنسپتی تیل کی ہائیڈروجنیشن (d)

سب سے صحیح جواب چنئے:

Options :

86435120349. (a)-(i), (b)-(iii), (c)-(ii), (d)-(iv)

86435120350. (a)-(iv), (b)-(ii), (c)-(i), (d)-(iii)

86435120351. (a)-(iii), (b)-(i), (c)-(iv), (d)-(ii)

86435120352. (a)-(ii), (b)-(iv), (c)-(i), (d)-(iii)

Question Number : 34 Question Id : 8643516784 Question Type : MCQ Option Shuffling : Yes Is Question Mandatory : No

Correct Marks : 4 Wrong Marks : 1

The ionic radius of Na⁺ ion is 1.02 Å. The ionic radii (in Å) of Mg²⁺ and Al³⁺, respectively, are :

Options :

86435120353. 0.85 and 0.99

86435120354. 0.72 and 0.54

86435120355. 0.68 and 0.72

86435120356. 1.05 and 0.99

Question Number : 34 Question Id : 8643516784 Question Type : MCQ Option Shuffling : Yes Is Question Mandatory : No

Correct Marks : 4 Wrong Marks : 1

: Na^+ آئن کی آئن نصف قطر 1.02 \AA ہے۔ تو Mg^{2+} اور Al^{3+} کے آئن نصف قطر با ترتیب ہونگے :

Options :

86435120353. 0.85 اور 0.99

86435120354. 0.72 اور 0.54

86435120355. 0.68 اور 0.72

86435120356. 1.05 اور 0.99

Question Number : 35 Question Id : 8643516785 Question Type : MCQ Option Shuffling : Yes Is Question Mandatory : No

Correct Marks : 4 Wrong Marks : 1

The chemical that is added to reduce the melting point of the reaction mixture during the extraction of aluminium is :

Options :

86435120357. Bauxite

86435120358. Kaolite

86435120359. Calamine

86435120360. Cryolite

Question Number : 35 Question Id : 8643516785 Question Type : MCQ Option Shuffling : Yes Is Question Mandatory : No

Correct Marks : 4 Wrong Marks : 1

: المونیم کو نکالنے کے عمل میں کون سے کیمیا کو تعامل آمیزہ کے نقطہ پگلاؤ کو کم کرنے کے لئے ملایا جاتا ہے :

Options :

86435120357. بوکسائیٹ

86435120358. کیلونائیٹ

86435120359. کیلامین

86435120360. کریولائٹ

Question Number : 36 Question Id : 8643516786 Question Type : MCQ Option Shuffling : Yes Is Question Mandatory : No Correct Marks : 4 Wrong Marks : 1

Given below are two Statements : One is labelled as Assertion A and the other is labelled as Reason R :

Assertion A : During the boiling of water having temporary hardness, $Mg(HCO_3)_2$ is converted to $MgCO_3$.

Reason R : The solubility product of $Mg(OH)_2$ is greater than that of $MgCO_3$.

In the light of the above statements, choose the most appropriate answer from the options given below :

Options :

86435120361. Both A and R are true and R is the correct explanation of A

86435120362. Both A and R are true but R is NOT the correct explanation of A

86435120363. A is true but R is false

86435120364. A is false but R is true

Question Number : 36 Question Id : 8643516786 Question Type : MCQ Option Shuffling : Yes Is Question Mandatory : No Correct Marks : 4 Wrong Marks : 1

نیچے دو جملے دیئے گئے ہیں: ایک دعویٰ "A" ہے اور دوسرا اسکی دلیل "R"

دعویٰ A : عارضی طور پر سخت پانی کو ابالنے سے $MgCO_3$, $Mg(HCO_3)_2$ میں تبدیل ہوتا ہے۔

دلیل R : $Mg(OH)_2$ کا حل پذیری حاصل $MgCO_3$ سے زیادہ ہے۔

سب سے مناسب جواب چنئے۔

Options :

86435120361. دونوں A اور R صحیح ہے اور R، A کی صحیح دلیل ہے۔

86435120362. دونوں A اور R صحیح ہے اور R، A کی صحیح دلیل نہیں ہے۔

86435120363. A صحیح ہے اور R غلط ہے۔

86435120364. A غلط ہے اور R صحیح ہے۔

Question Number : 37 Question Id : 8643516787 Question Type : MCQ Option Shuffling : Yes Is Question Mandatory : No

Correct Marks : 4 Wrong Marks : 1

Match List - I with List - II :

List - I	List - II
(a) $\text{Ca}(\text{OCl})_2$	(i) Antacid
(b) $\text{CaSO}_4 \cdot \frac{1}{2}\text{H}_2\text{O}$	(ii) Cement
(c) CaO	(iii) Bleach
(d) CaCO_3	(iv) Plaster of Paris

Choose the most appropriate answer from the options given below :

Options :

86435120365. (a)-(i), (b)-(iv), (c)-(iii), (d)-(ii)

86435120366. (a)-(iii), (b)-(ii), (c)-(i), (d)-(iv)

86435120367. (a)-(iii), (b)-(ii), (c)-(iv), (d)-(i)

86435120368. (a)-(iii), (b)-(iv), (c)-(ii), (d)-(i)

Question Number : 37 Question Id : 8643516787 Question Type : MCQ Option Shuffling : Yes Is Question Mandatory : No

Correct Marks : 4 Wrong Marks : 1

فہرست I کو فہرست II سے ملائیں۔

فہرست II	فہرست I
(i) ضد تیزاب	Ca(OCl) ₂ (a)
(ii) سینٹ	CaSO ₄ · $\frac{1}{2}$ H ₂ O (b)
(iii) پٹیج	CaO (c)
(iv) پلاسٹر آف پیرس	CaCO ₃ (d)

سب سے مناسب جواب چنئے:

Options :

86435120365. (a)-(i), (b)-(iv), (c)-(iii), (d)-(ii)

86435120366. (a)-(iii), (b)-(ii), (c)-(i), (d)-(iv)

86435120367. (a)-(iii), (b)-(ii), (c)-(iv), (d)-(i)

86435120368. (a)-(iii), (b)-(iv), (c)-(ii), (d)-(i)

Question Number : 38 Question Id : 8643516788 Question Type : MCQ Option Shuffling : Yes Is Question Mandatory : No

Correct Marks : 4 Wrong Marks : 1

The number of ionisable hydrogens present in the product obtained from a reaction of phosphorus trichloride and phosphonic acid is :

Options :

86435120369. 1

86435120370. 2

86435120371. 0

86435120372. 3

Question Number : 38 Question Id : 8643516788 Question Type : MCQ Option Shuffling : Yes Is Question Mandatory : No

Correct Marks : 4 Wrong Marks : 1

فاسفورس ٹرانکلورائیڈ اور فاسٹونک تیزاب کے تعامل سے بننے والے مرکب میں کتنے "آینائز یہیل" (ionisable) ہائیڈروجنس ہونگے:

Options :

86435120369. 1

86435120370. 2

86435120371. 0

86435120372. 3

Question Number : 39 Question Id : 8643516789 Question Type : MCQ Option Shuffling : Yes Is Question Mandatory : No

Correct Marks : 4 Wrong Marks : 1

Match List - I with List - II :

List - I	List - II
(a) Chlorophyll	(i) Ruthenium
(b) Vitamin - B ₁₂	(ii) Platinum
(c) Anticancer drug	(iii) Cobalt
(d) Grubbs catalyst	(iv) Magnesium

Choose the most appropriate answer from the options given below :

Options :

86435120373. (a)-(iii), (b)-(ii), (c)-(iv), (d)-(i)

86435120374. (a)-(iv), (b)-(iii), (c)-(ii), (d)-(i)

86435120375. (a)-(iv), (b)-(ii), (c)-(iii), (d)-(i)

86435120376. (a)-(iv), (b)-(iii), (c)-(i), (d)-(ii)

Question Number : 39 Question Id : 8643516789 Question Type : MCQ Option Shuffling : Yes Is Question Mandatory : No

Correct Marks : 4 Wrong Marks : 1

فہرست I اور فہرست II کو ملائیں :

فہرست II		فہرست I
روٹینیم	(i)	کلوروفل (a)
پلیٹنم	(ii)	وائٹمن-B ₁₂ (b)
کوبالٹ	(iii)	اینٹی کینسر وائی (c)
میگنیشیم	(iv)	گرہس کیٹالسٹ (d)

دیئے گئے جوابات میں سے صحیح چنئے :

Options :

86435120373. (a)-(iii), (b)-(ii), (c)-(iv), (d)-(i)

86435120374. (a)-(iv), (b)-(iii), (c)-(ii), (d)-(i)

86435120375. (a)-(iv), (b)-(ii), (c)-(iii), (d)-(i)

86435120376. (a)-(iv), (b)-(iii), (c)-(i), (d)-(ii)

Question Number : 40 Question Id : 8643516790 Question Type : MCQ Option Shuffling : Yes Is Question Mandatory : No

Correct Marks : 4 Wrong Marks : 1

The correct structures of trans-[NiBr₂(PPh₃)₂] and meridional-[Co(NH₃)₃(NO₂)₃], respectively, are :

Options :

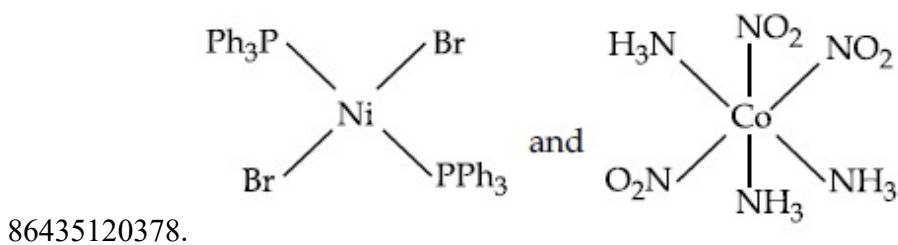
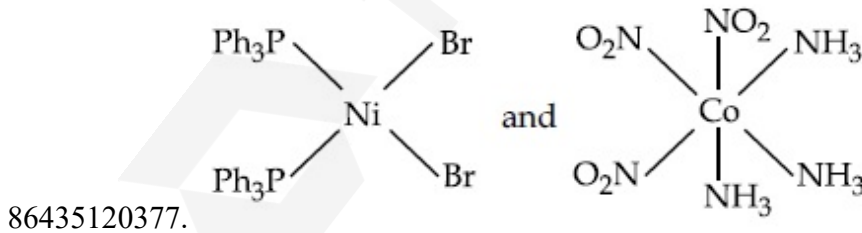

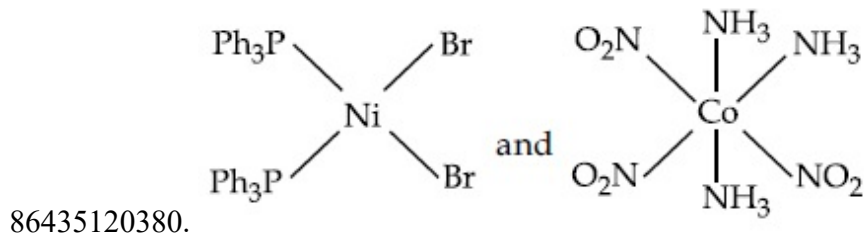
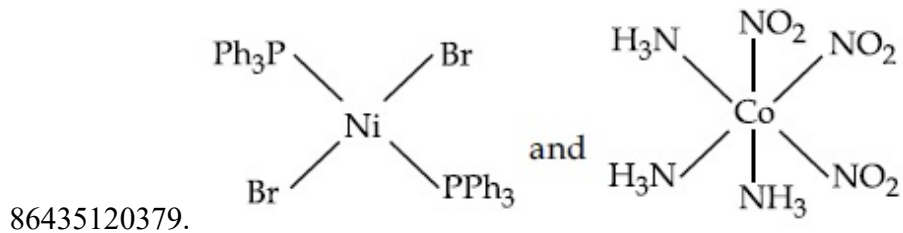

Question Number : 40 Question Id : 8643516790 Question Type : MCQ Option Shuffling : Yes Is Question Mandatory : No

Correct Marks : 4 Wrong Marks : 1

meridional- $[\text{Co}(\text{NH}_3)_3(\text{NO}_2)_3]$ اور $[\text{NiBr}_2(\text{PPh}_3)_2]$ کی بالترتیب بناوٹ کیا ہوگی :

Options :

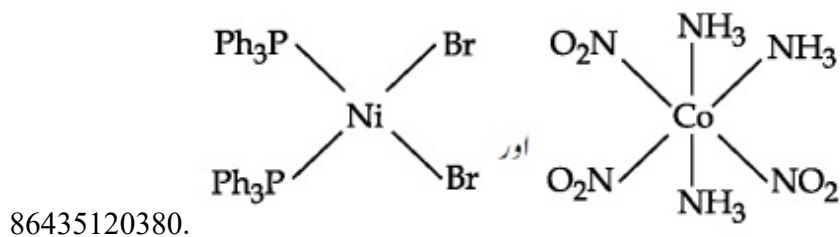
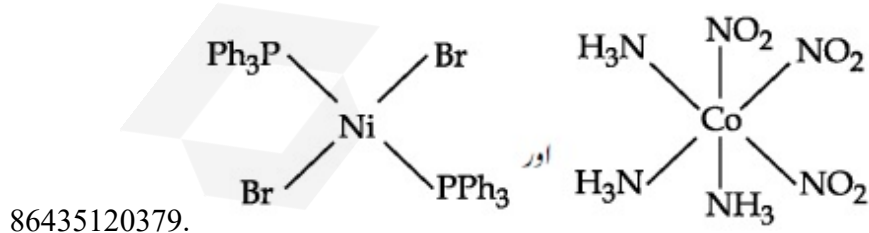
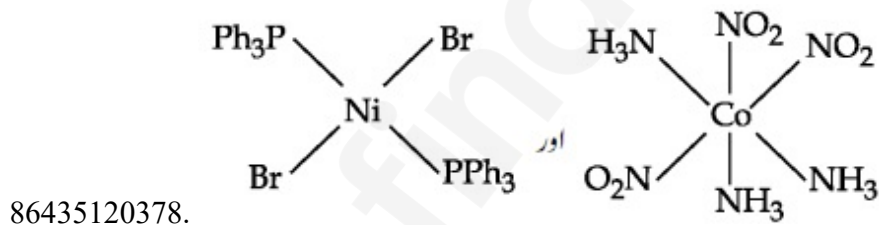
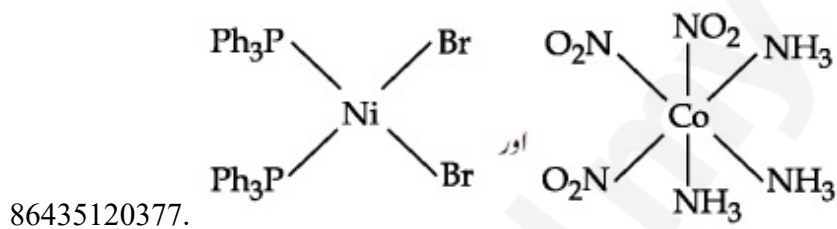

Question Number : 41 Question Id : 8643516791 Question Type : MCQ Option Shuffling : Yes Is

Question Mandatory : No

Correct Marks : 4 Wrong Marks : 1

The statements that are TRUE :

- (A) methane leads to both global warming and photochemical smog
- (B) methane is generated from paddy fields
- (C) methane is a stronger global warming gas than CO₂
- (D) methane is a part of reducing smog.

Choose the most appropriate answer from the options given below :

Options :

86435120381. (A) and (B) only

86435120382. (A), (B), (C) only

86435120383. (B), (C), (D) only

86435120384. (A), (B), (D) only

Question Number : 41 Question Id : 8643516791 Question Type : MCQ Option Shuffling : Yes Is

Question Mandatory : No

Correct Marks : 4 Wrong Marks : 1

صحیح جملے کون سے ہیں:

- (A) میتھین کی وجہ سے عالمی گرمی ہوتی ہے اور فوٹو کیمیکل سماگ بنتا ہے۔
- (B) میتھین دھان کے کھیت سے نکلتی ہے۔
- (C) میتھین کاربن ڈائی آکسائیڈ سے زیادہ اثر دار عالمی گرمی کرنے والا گیس ہے۔
- (D) میتھین تھوہلی سماگ کا حصہ ہے۔

صحیح جواب چنئے:

Options :

86435120381. صرف (A) اور (B)

86435120382. (A), (B), اور (C)

86435120383. (D) اور ,(C) ,(B)

86435120384. (D) اور ,(B) ,(A)

Question Number : 42 Question Id : 8643516792 Question Type : MCQ Option Shuffling : Yes Is Question Mandatory : No

Correct Marks : 4 Wrong Marks : 1

Compound with molecular formula C_3H_6O can show :

Options :

86435120385. Positional isomerism

86435120386. Functional group isomerism

86435120387. Metamerism

86435120388. Both positional isomerism and metamerism

Question Number : 42 Question Id : 8643516792 Question Type : MCQ Option Shuffling : Yes Is Question Mandatory : No

Correct Marks : 4 Wrong Marks : 1

مرکب جس کا سالمی ضابطہ C_3H_6O ہے کیا دکھا سکتا ہے :

Options :

86435120385. پوزیشنل ایسومریزم

86435120386. فنکشنل گروپ ایسومریزم

86435120387. میٹامریزم

86435120388. دونوں پوزیشنل ایسومریزم اور میٹامریزم

Question Number : 43 Question Id : 8643516793 Question Type : MCQ Option Shuffling : Yes Is Question Mandatory : No

Correct Marks : 4 Wrong Marks : 1

Match List - I with List - II :

List - I

(Chemicals)

- (a) Alcoholic potassium hydroxide
 (b) Pd/BaSO₄
 (c) BHC (Benzene hexachloride)
 (d) Polyacetylene

List - II

(Use/Preparation/Constituent)

- (i) electrodes in batteries
 (ii) obtained by addition reaction
 (iii) used for β-elimination reaction
 (iv) Lindlar's Catalyst

Choose the most appropriate match :

Options :

86435120389. (a)-(ii), (b)-(i), (c)-(iv), (d)-(iii)

86435120390. (a)-(iii), (b)-(i), (c)-(iv), (d)-(ii)

86435120391. (a)-(ii), (b)-(iv), (c)-(i), (d)-(iii)

86435120392. (a)-(iii), (b)-(iv), (c)-(ii), (d)-(i)

Question Number : 43 Question Id : 8643516793 Question Type : MCQ Option Shuffling : Yes Is Question Mandatory : No

Correct Marks : 4 Wrong Marks : 1

فہرست I اور فہرست II کو ملائیں:

فہرست II

استعمال / ترکیب / اجزائے ترکیبی

- (i) بیٹری الیکٹروڈس
 (ii) ایڈیشن تعامل سے حاصل شدہ
 (iii) β-لیہیمینیشن تعامل کے لئے استعمال
 (iv) لینڈلارس کیٹالسٹ

فہرست I

(کیمیا)

- (a) آلکوہولک پوٹاشیم ہائیڈروآکسائیڈ
 (b) Pd/BaSO₄
 (c) BHC (ہینڈین ہیکساکلورائیڈ)
 (d) پولی اسیٹیلین

صحیح جواب چنئے:

Options :

86435120389. (a)-(ii), (b)-(i), (c)-(iv), (d)-(iii)

86435120390. (a)-(iii), (b)-(i), (c)-(iv), (d)-(ii)

86435120391. (a)-(ii), (b)-(iv), (c)-(i), (d)-(iii)

86435120392. (a)-(iii), (b)-(iv), (c)-(ii), (d)-(i)

Question Number : 44 Question Id : 8643516794 Question Type : MCQ Option Shuffling : Yes Is Question Mandatory : No

Correct Marks : 4 Wrong Marks : 1

Reaction of Grignard reagent, C_2H_5MgBr with C_8H_8O followed by hydrolysis gives compound "A" which reacts instantly with Lucas reagent to give compound B, $C_{10}H_{13}Cl$.

The Compound B is :

Options :

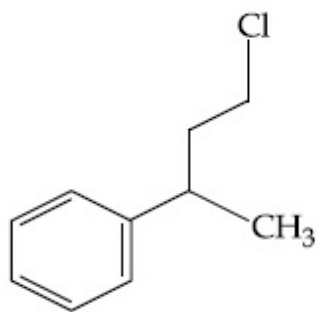

86435120393.

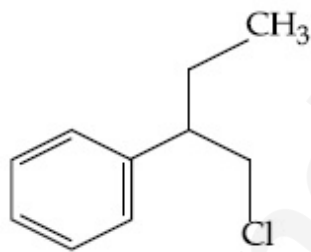

86435120394.

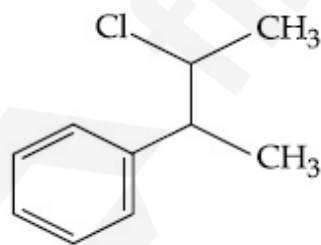

86435120395.

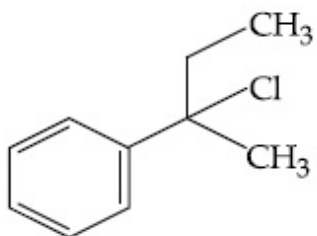

86435120396.

Question Number : 44 Question Id : 8643516794 Question Type : MCQ Option Shuffling : Yes Is
 Question Mandatory : No
 Correct Marks : 4 Wrong Marks : 1

گرگنا لڈ عامل C_2H_5MgBr ، C_8H_8O کے ساتھ تعامل کر کے "A" بناتا ہے۔
 "A" فوری طور پر "لیکاس" عامل سے ملکر B ($C_{10}H_{13}Cl$) بناتا ہے۔
 مرکب B کون سا ہے۔

Options :

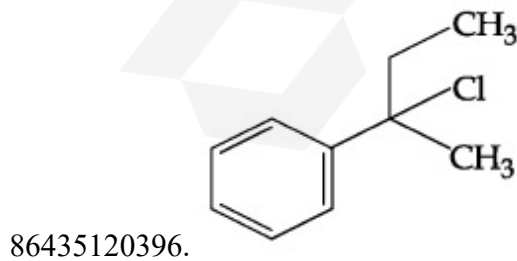
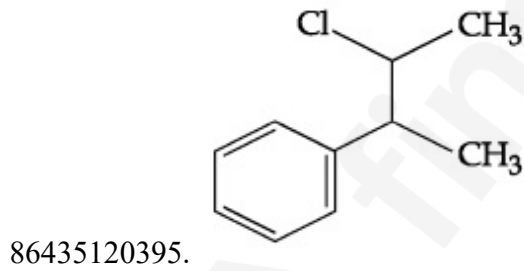
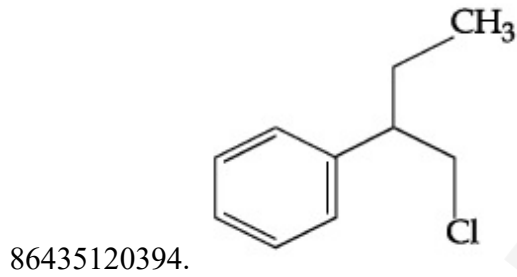
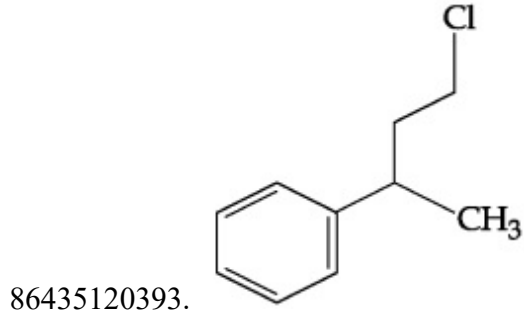

Question Number : 45 Question Id : 8643516795 Question Type : MCQ Option Shuffling : Yes Is
 Question Mandatory : No
 Correct Marks : 4 Wrong Marks : 1

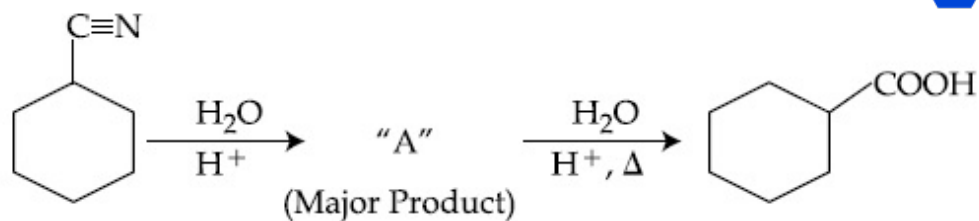

Consider the above chemical reaction and identify product "A" :

Options :

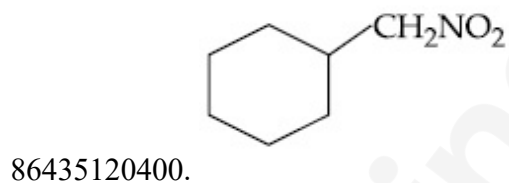
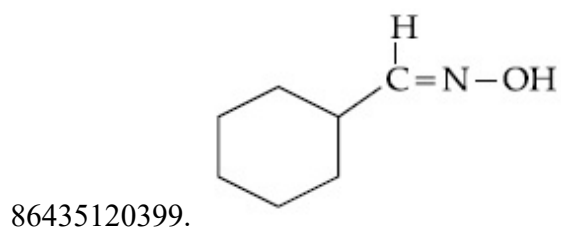
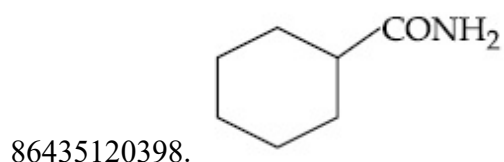
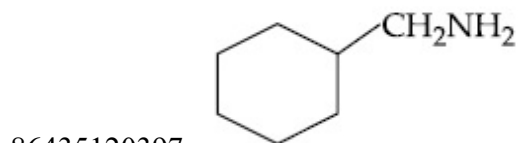

Question Number : 45 Question Id : 8643516795 Question Type : MCQ Option Shuffling : Yes Is

Question Mandatory : No

Correct Marks : 4 Wrong Marks : 1

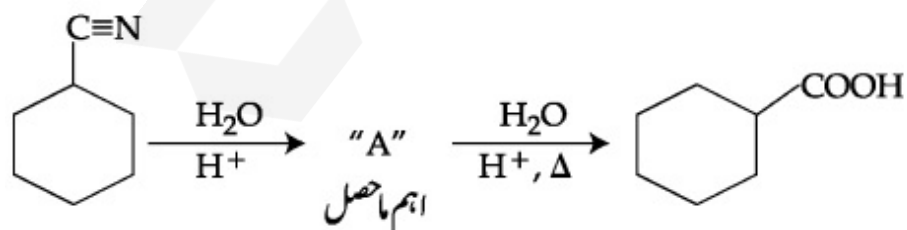

اوپر دی گئی تعامل پر غور کریں اور "A" کو پہچانیں :

Options :

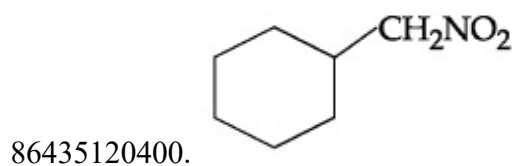
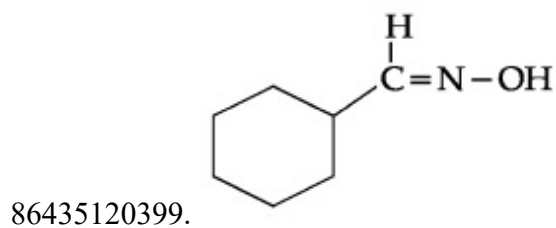
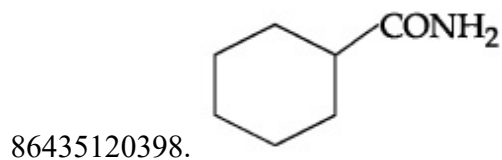
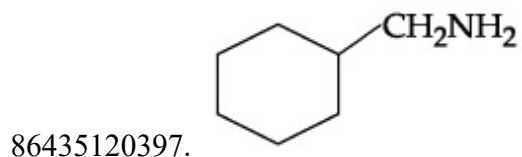

Question Number : 46 Question Id : 8643516796 Question Type : MCQ Option Shuffling : Yes Is Question Mandatory : No Correct Marks : 4 Wrong Marks : 1

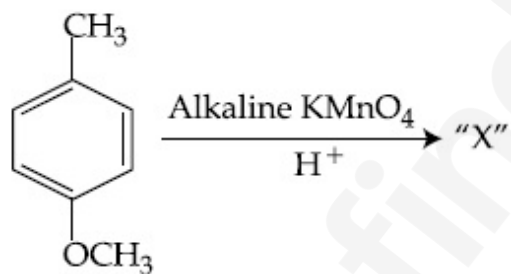

Considering the above chemical reaction, identify the product "X" :

Options :

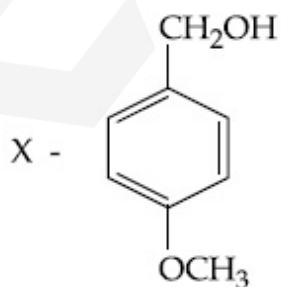

86435120401.

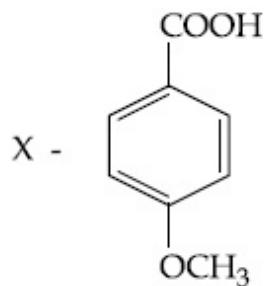

86435120402.

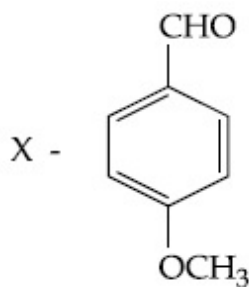

86435120403.

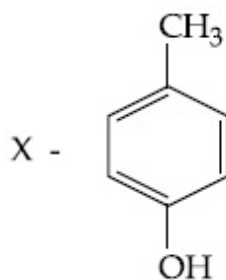

86435120404.

Question Number : 46 Question Id : 8643516796 Question Type : MCQ Option Shuffling : Yes Is Question Mandatory : No

Correct Marks : 4 Wrong Marks : 1

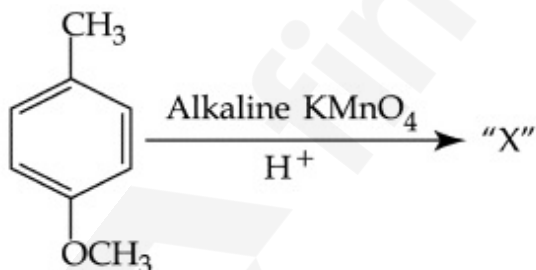

اوپر دی گئی تعامل پر غور کریں اور ما حاصل مرکب "X" کو پہچانیں :

Options :

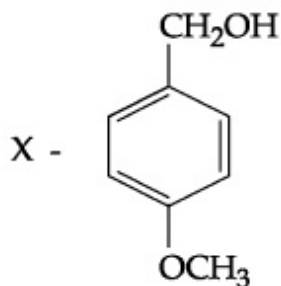

86435120401.

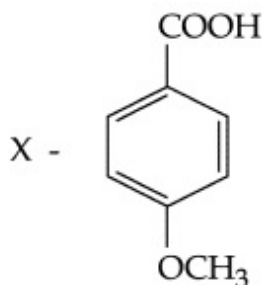

86435120402.

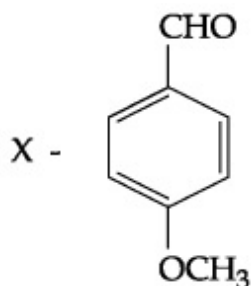

86435120403.

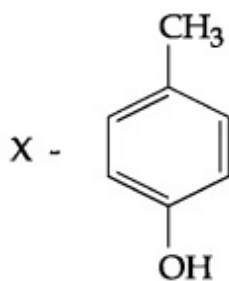

86435120404.

Question Number : 47 Question Id : 8643516797 Question Type : MCQ Option Shuffling : Yes Is Question Mandatory : No Correct Marks : 4 Wrong Marks : 1

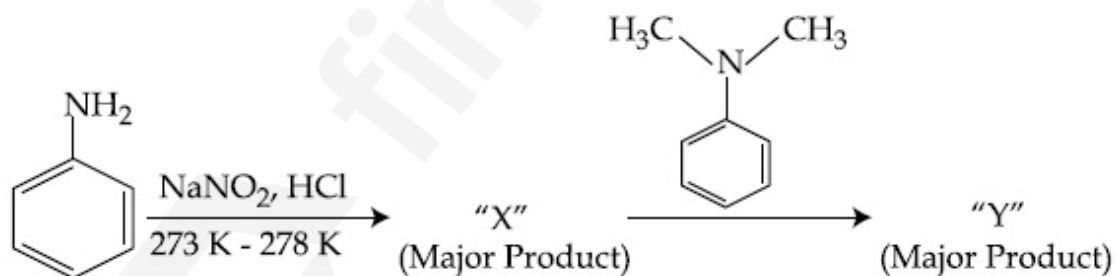

Considering the above reaction, X and Y respectively are :

Options :

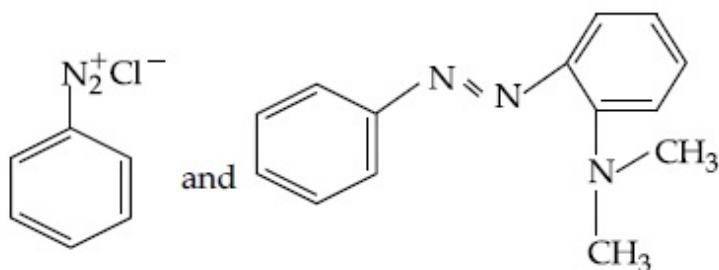

86435120405.

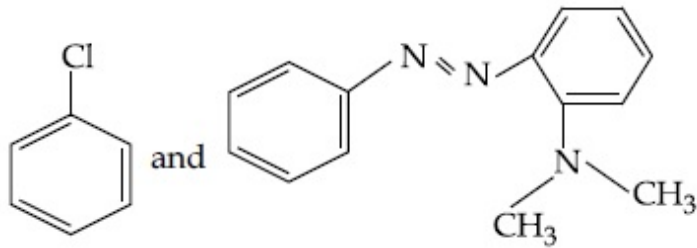

86435120406.

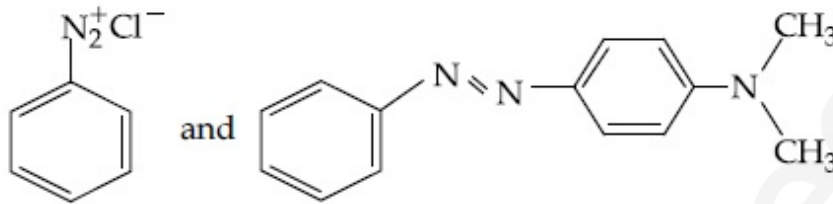

86435120407.

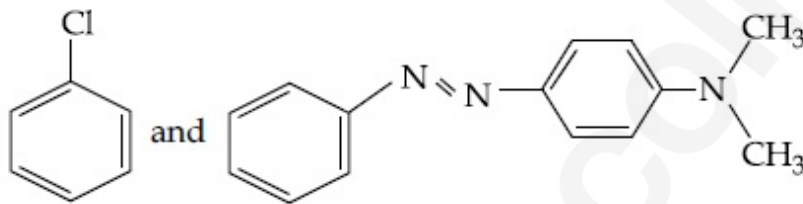

86435120408.

Question Number : 47 Question Id : 8643516797 Question Type : MCQ Option Shuffling : Yes Is Question Mandatory : No Correct Marks : 4 Wrong Marks : 1

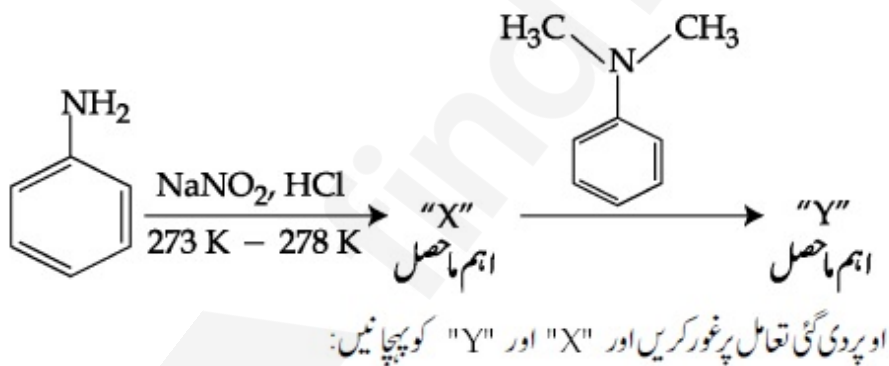

Options :

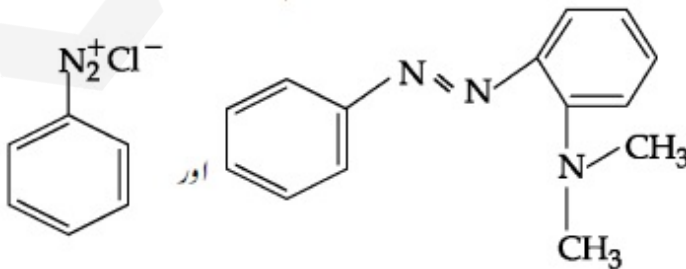

86435120405.

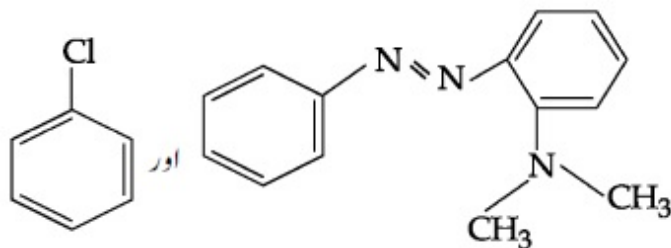

86435120406.

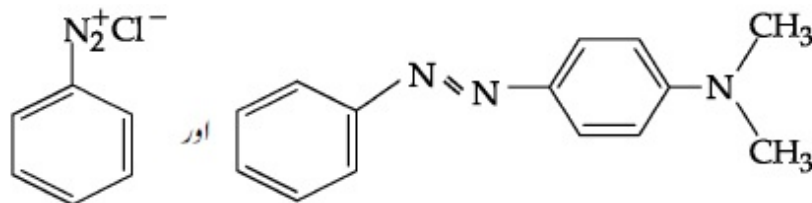

86435120407.

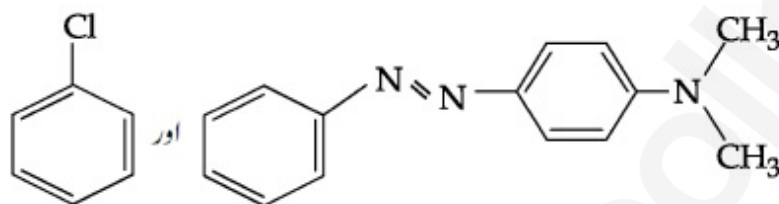

86435120408.

Question Number : 48 Question Id : 8643516798 Question Type : MCQ Option Shuffling : Yes Is Question Mandatory : No

Correct Marks : 4 Wrong Marks : 1

Match List - I with List - II :

List - I	List - II
(Class of Drug)	(Example)
(a) Antacid	(i) Novestrol
(b) Artificial Sweetener	(ii) Cimetidine
(c) Antifertility	(iii) Valium
(d) Tranquilizers	(iv) Alitame

Choose the most appropriate match :

Options :

86435120409. (a)-(ii), (b)-(iv), (c)-(iii), (d)-(i)

86435120410. (a)-(ii), (b)-(iv), (c)-(i), (d)-(iii)

86435120411. (a)-(iv), (b)-(i), (c)-(ii), (d)-(iii)

86435120412. (a)-(iv), (b)-(iii), (c)-(i), (d)-(ii)

Question Number : 48 Question Id : 8643516798 Question Type : MCQ Option Shuffling : Yes Is

Question Mandatory : No

Correct Marks : 4 Wrong Marks : 1

فہرست-I اور فہرست-II کو ملائیں:

فہرست-II		فہرست-I	
(مثال)		(دوائی کی قسم)	
نوویسٹرال	(i)	ضدتیزابی	(a)
سمیٹائیزین	(ii)	بناوٹی مٹھاس	(b)
ولیم	(iii)	اینٹی فرٹیلیٹی	(c)
علیٹیم	(iv)	تسکین کے لئے	(d)

صحیح جواب چنئے:

Options :

86435120409. (a)-(ii), (b)-(iv), (c)-(iii), (d)-(i)

86435120410. (a)-(ii), (b)-(iv), (c)-(i), (d)-(iii)

86435120411. (a)-(iv), (b)-(i), (c)-(ii), (d)-(iii)

86435120412. (a)-(iv), (b)-(iii), (c)-(i), (d)-(ii)

Question Number : 49 Question Id : 8643516799 Question Type : MCQ Option Shuffling : Yes Is

Question Mandatory : No

Correct Marks : 4 Wrong Marks : 1

A non-reducing sugar "A" hydrolyses to give two reducing mono saccharides. Sugar A is :

Options :

86435120413. Glucose

86435120414. Fructose

86435120415. Galactose

86435120416. Sucrose

Question Number : 49 Question Id : 8643516799 Question Type : MCQ Option Shuffling : Yes Is

Question Mandatory : No

Correct Marks : 4 Wrong Marks : 1

ایک غیر تھوہلی شوگر "A" آب پاش ہو کر دو تھوہلی "مانوسیکرائڈ" بناتا ہے۔ شوگر A کیا ہے:

Options :

86435120413. گلوکوز

86435120414. فرائٹوز

86435120415. گلیکولوز

86435120416. سکروز

Question Number : 50 Question Id : 8643516800 Question Type : MCQ Option Shuffling : Yes Is

Question Mandatory : No

Correct Marks : 4 Wrong Marks : 1

Reagent, 1-naphthylamine and sulphanilic acid in acetic acid is used for the detection of :

Options :

86435120417. NO_2^-

86435120418. NO_3^-

86435120419. NO

86435120420. N_2O

Question Number : 50 Question Id : 8643516800 Question Type : MCQ Option Shuffling : Yes Is

Question Mandatory : No

Correct Marks : 4 Wrong Marks : 1

متعامل، اسینک تیزاب میں 1-سپھٹائیل آمین اور سلفانیلک تیزاب، کس کی شناخت کے لئے استعمال ہوتا ہے:

Options :

86435120417. NO_2^-

86435120418. NO_3^-

86435120419. NO

86435120420. N_2O

Chemistry Section B

Section Id :	864351454
Section Number :	4
Section type :	Online
Mandatory or Optional :	Mandatory
Number of Questions :	10
Number of Questions to be attempted :	5
Section Marks :	20
Mark As Answered Required? :	Yes
Sub-Section Number :	1
Sub-Section Id :	864351454
Question Shuffling Allowed :	Yes

Question Number : 51 Question Id : 8643516801 Question Type : SA

Correct Marks : 4 Wrong Marks : 0

Complete combustion of 3 g of ethane gives $x \times 10^{22}$ molecules of water. The value of x is _____ . (Round off to the Nearest Integer).

[Use : $N_A = 6.023 \times 10^{23}$; Atomic masses in u : C : 12.0 ; O : 16.0 ; H : 1.0]

Response Type : Numeric

Evaluation Required For SA : Yes

Show Word Count : Yes

Answers Type : Equal

Text Areas : PlainText

Possible Answers :

100

Question Number : 51 Question Id : 8643516801 Question Type : SA

Correct Marks : 4 Wrong Marks : 0

انتھین کی 3 g پوری طرح سے جلنے کے بعد $x \times 10^{22}$ پانی کے سالمے دیتا ہے۔ x کی قدر _____ ہے۔ (قریب تکمیل عدد)

[استعمال کریں : $N_A = 6.023 \times 10^{23}$ ؛ u میں جوہری وزن : C : 12.0 ، O : 16.0 ، H : 1.0 اور]

Response Type : Numeric

Evaluation Required For SA : Yes

Show Word Count : Yes

Answers Type : Equal

Text Areas : PlainText

Possible Answers :

100

Question Number : 52 **Question Id :** 8643516802 **Question Type :** SA

Correct Marks : 4 **Wrong Marks :** 0

AX is a covalent diatomic molecule where A and X are second row elements of periodic table. Based on Molecular orbital theory, the bond order of AX is 2.5. The total number of electrons in AX is _____. (Round off to the Nearest Integer).

Response Type : Numeric

Evaluation Required For SA : Yes

Show Word Count : Yes

Answers Type : Equal

Text Areas : PlainText

Possible Answers :

100

Question Number : 52 **Question Id :** 8643516802 **Question Type :** SA

Correct Marks : 4 **Wrong Marks :** 0

AX دو جوہری سالمہ ہے اور "A" اور "X" دونوں کییمیائی دوری جدول دوسری قطار کے عنصر ہیں۔ بمطابق "مائیکرو لائرڈیٹیل تھیوری" کا AX کا بانڈ آرڈر 2.5 ہے۔

AX میں کل _____ الیکٹرانس ہونگے۔ (قریب تکمیل عدد)

Response Type : Numeric

Evaluation Required For SA : Yes

Show Word Count : Yes

Answers Type : Equal

Text Areas : PlainText

Possible Answers :

100

Question Number : 53 **Question Id :** 8643516803 **Question Type :** SA

Correct Marks : 4 **Wrong Marks :** 0

For the reaction

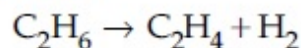

the reaction enthalpy $\Delta_r H = \text{_____}$ kJ mol⁻¹. (Round off to the Nearest Integer).

[Given : Bond enthalpies in kJ mol⁻¹ : C-C : 347, C=C : 611;

C-H : 414, H-H : 436]

Response Type : Numeric

Evaluation Required For SA : Yes

Show Word Count : Yes

Answers Type : Equal

Text Areas : PlainText

Possible Answers :

100

Question Number : 53 **Question Id :** 8643516803 **Question Type :** SA

Correct Marks : 4 **Wrong Marks :** 0

دی گئی تعامل کے لئے

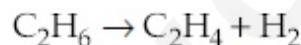

تفاعل اینتھالپی $\Delta_r H = \text{_____}$ kJ mol⁻¹ ہوگی۔ (قریب تکمیل عدد)

[دیا گیا ہے : بانڈ اینتھالپی kJ mol⁻¹ میں :

C=C : 611 ، C-C : 347

[H-H : 436 ، C-H : 414

Response Type : Numeric

Evaluation Required For SA : Yes

Show Word Count : Yes

Answers Type : Equal

Text Areas : PlainText

Possible Answers :

100

Question Number : 54 **Question Id :** 8643516804 **Question Type :** SA

Correct Marks : 4 **Wrong Marks :** 0

2 molal solution of a weak acid HA has a freezing point of 3.885°C. The degree of dissociation of this acid is $\text{_____} \times 10^{-3}$. (Round off to the Nearest Integer).

[Given : Molal depression constant of water = 1.85 K kg mol⁻¹

Freezing point of pure water = 0°C]

Response Type : Numeric

Evaluation Required For SA : Yes

Show Word Count : Yes

Answers Type : Equal

Text Areas : PlainText

Possible Answers :

100

Question Number : 54 **Question Id :** 8643516804 **Question Type :** SA

Correct Marks : 4 **Wrong Marks :** 0

ایک کمزور تیزاب کے 2 مول مل محلول کا نقطہ جمائو 3.885°C ہے۔ اس تیزاب کا علیحدگی کا نقطہ $10^{-3} \times \text{_____}$ ہوگا۔
(قریب تکمیل عدد)

(دیا گیا: 'مولل ڈیپریشن'، مستقلہ پانی کے لئے $= 1.85 \text{ K kg mol}^{-1}$ ، پانی کا نقطہ جمائو 0°C)

Response Type : Numeric

Evaluation Required For SA : Yes

Show Word Count : Yes

Answers Type : Equal

Text Areas : PlainText

Possible Answers :

100

Question Number : 55 **Question Id :** 8643516805 **Question Type :** SA

Correct Marks : 4 **Wrong Marks :** 0

In order to prepare a buffer solution of pH 5.74, sodium acetate is added to acetic acid. If the concentration of acetic acid in the buffer is 1.0 M, the concentration of sodium acetate in the buffer is _____ M. (Round off to the Nearest Integer).

[Given : pKa (acetic acid) = 4.74]

Response Type : Numeric

Evaluation Required For SA : Yes

Show Word Count : Yes

Answers Type : Equal

Text Areas : PlainText

Possible Answers :

100

Question Number : 55 **Question Id :** 8643516805 **Question Type :** SA

Correct Marks : 4 **Wrong Marks :** 0

pH 5.74 کے "بفر" (buffer) محلول کو بنانے کے لئے سوڈیم اسپیٹ کو اسپیٹک تیزاب سے ملایا جاتا ہے۔ اگر اسپیٹک تیزاب کی مقدار بفر محلول میں 1.0 M ہے تو سوڈیم اسپیٹک کی مقدار _____ M ہوگی۔ (قریب تکمیل عدد) دیا گیا (pKa (اسپیٹک تیزاب) = 4.74)

Response Type : Numeric

Evaluation Required For SA : Yes

Show Word Count : Yes

Answers Type : Equal

Text Areas : PlainText

Possible Answers :

100

Question Number : 56 **Question Id :** 8643516806 **Question Type :** SA

Correct Marks : 4 **Wrong Marks :** 0

For the reaction

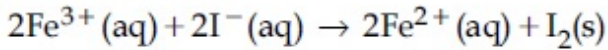

the magnitude of the standard molar free energy change,

$\Delta_r G_m^\circ = -$ _____ kJ (Round off to the Nearest Integer).

$$\left[\begin{array}{l} E^\circ_{\text{Fe}^{2+}/\text{Fe}(\text{s})} = -0.440 \text{ V} ; E^\circ_{\text{Fe}^{3+}/\text{Fe}(\text{s})} = -0.036 \text{ V} \\ E^\circ_{\text{I}_2/2\text{I}^{-}} = 0.539 \text{ V} ; F = 96500 \text{ C} \end{array} \right]$$

Response Type : Numeric

Evaluation Required For SA : Yes

Show Word Count : Yes

Answers Type : Equal

Text Areas : PlainText

Possible Answers :

100

Question Number : 56 **Question Id :** 8643516806 **Question Type :** SA

Correct Marks : 4 **Wrong Marks :** 0

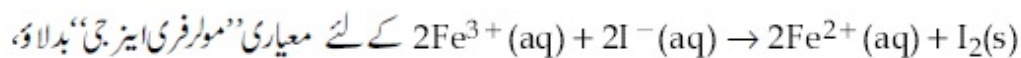

$$- \Delta_r G_m^\circ = - \text{_____ kJ} \quad (\text{قریب تکمیل عدد})$$

$$\left[\begin{array}{l} E^\circ_{\text{Fe}^{2+}/\text{Fe}(\text{s})} = -0.440 \text{ V}; E^\circ_{\text{Fe}^{3+}/\text{Fe}(\text{s})} = -0.036 \text{ V} \\ E^\circ_{\text{I}_2/2\text{I}^{-}} = 0.539 \text{ V}; \quad F = 96500 \text{ C} \end{array} \right]$$

Response Type : Numeric

Evaluation Required For SA : Yes

Show Word Count : Yes

Answers Type : Equal

Text Areas : PlainText

Possible Answers :

100

Question Number : 57 **Question Id :** 8643516807 **Question Type :** SA

Correct Marks : 4 **Wrong Marks :** 0

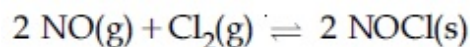

This reaction was studied at -10°C and the following data was obtained

run	$[\text{NO}]_0$	$[\text{Cl}_2]_0$	r_0
1	0.10	0.10	0.18
2	0.10	0.20	0.35
3	0.20	0.20	1.40

$[\text{NO}]_0$ and $[\text{Cl}_2]_0$ are the initial concentrations and r_0 is the initial reaction rate.

The overall order of the reaction is _____. (Round off to the Nearest Integer).

Response Type : Numeric

Evaluation Required For SA : Yes

Show Word Count : Yes

Answers Type : Equal

Text Areas : PlainText

Possible Answers :

100

Question Number : 57 **Question Id :** 8643516807 **Question Type :** SA

Correct Marks : 4 **Wrong Marks :** 0

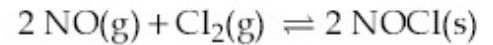

اس تعامل کا 10°C پر مطالعہ کیا گیا تو مندرجہ ذیل ڈاٹا ملا :

r_0	$[\text{Cl}_2]_0$	$[\text{NO}]_0$	run
0.18	0.10	0.10	1
0.35	0.20	0.10	2
1.40	0.20	0.20	3

اگر $[\text{NO}]_0$ اور $[\text{Cl}_2]_0$ ابتدائی مقدار ہیں اور r_0 ابتدائی تعامل وقفہ ہے تو مجموعی تعامل آرڈر _____ ہوگا۔ (قریباً تکمیل عدد)

Response Type : Numeric

Evaluation Required For SA : Yes

Show Word Count : Yes

Answers Type : Equal

Text Areas : PlainText

Possible Answers :

100

Question Number : 58 **Question Id :** 8643516808 **Question Type :** SA

Correct Marks : 4 **Wrong Marks :** 0

The total number of unpaired electrons present in the complex $\text{K}_3[\text{Cr}(\text{oxalate})_3]$ is _____.

Response Type : Numeric

Evaluation Required For SA : Yes

Show Word Count : Yes

Answers Type : Equal

Text Areas : PlainText

Possible Answers :

100

Question Number : 58 **Question Id :** 8643516808 **Question Type :** SA

Correct Marks : 4 **Wrong Marks :** 0

$\text{K}_3[\text{Cr}(\text{oxalate})_3]$ میں کل _____ بے جوڑے الیکٹرانس ہونگے۔

Response Type : Numeric

Evaluation Required For SA : Yes

Show Word Count : Yes

Answers Type : Equal

Text Areas : PlainText

Possible Answers :

100

Question Number : 59 Question Id : 8643516809 Question Type : SA

Correct Marks : 4 Wrong Marks : 0

_____ grams of 3-Hydroxy propanal (MW = 74) must be dehydrated to produce 7.8 g of acrolein (MW = 56) (C_3H_4O) if the percentage yield is 64. (Round off to the Nearest Integer).

[Given : Atomic masses : C : 12.0 u, H : 1.0 u, O : 16.0 u]

Response Type : Numeric

Evaluation Required For SA : Yes

Show Word Count : Yes

Answers Type : Equal

Text Areas : PlainText

Possible Answers :

100

Question Number : 59 Question Id : 8643516809 Question Type : SA

Correct Marks : 4 Wrong Marks : 0

3-ہیڈروکزی پروپینل کے _____ گرام کو اکریلین کے 7.8 g بنانے کے لئے ناپائید کرنا ضروری ہے، اگر فیصد پیداوار 64 ہے۔
(قریب تکمیل عدد)

[C : 12.0 u, H : 1.0 u, O : 16.0 u = دیئے گئے جوہری کمیتیں]

Response Type : Numeric

Evaluation Required For SA : Yes

Show Word Count : Yes

Answers Type : Equal

Text Areas : PlainText

Possible Answers :

100

Question Number : 60 Question Id : 8643516810 Question Type : SA

Correct Marks : 4 Wrong Marks : 0

A reaction of 0.1 mole of Benzylamine with bromomethane gave 23 g of Benzyl trimethyl ammonium bromide. The number of moles of bromomethane consumed in this reaction are $n \times 10^{-1}$, when $n =$ _____. (Round off to the Nearest Integer).

[Given : Atomic masses : C : 12.0 u, H : 1.0 u, N : 14.0 u, Br : 80.0 u]

Response Type : Numeric

Evaluation Required For SA : Yes

Show Word Count : Yes

Answers Type : Equal

Text Areas : PlainText

Possible Answers :

100

Question Number : 60 Question Id : 8643516810 Question Type : SA

Correct Marks : 4 Wrong Marks : 0

ہینڈل آئین کے 0.1 mole کا تعامل ”برومو میتھین“ کے ساتھ 23 g ”ہینڈل ٹرائی میتھائل امونیم برومائڈ“ دیتا ہے۔ اس تعامل میں ”برومو میتھین“ کے $n \times 10^{-1}$ (moles) خرچ ہوتے ہیں، تو n کی قدر _____ ہوگی۔ (قریب تکمیل عدد)

[C : 12.0 u, H : 1.0 u, N : 14.0 u, Br : 80.0 u = دیئے گئے جوہری کمیتیں]

Response Type : Numeric

Evaluation Required For SA : Yes

Show Word Count : Yes

Answers Type : Equal

Text Areas : PlainText

Possible Answers :

100

Mathematics Section A

Section Id :	864351455
Section Number :	5
Section type :	Online
Mandatory or Optional :	Mandatory
Number of Questions :	20
Number of Questions to be attempted :	20
Section Marks :	80
Mark As Answered Required? :	Yes
Sub-Section Number :	1
Sub-Section Id :	864351455
Question Shuffling Allowed :	Yes

Question Number : 61 Question Id : 8643516811 Question Type : MCQ Option Shuffling : Yes Is

Question Mandatory : No

Correct Marks : 4 Wrong Marks : 1

If the functions are defined as $f(x) = \sqrt{x}$ and $g(x) = \sqrt{1-x}$, then what is the common domain of the following functions : $f+g$, $f-g$, f/g , g/f , $g-f$ where

$$(f \pm g)(x) = f(x) \pm g(x), (f/g)(x) = \frac{f(x)}{g(x)}$$

Options :

86435120431. $0 \leq x < 1$

86435120432. $0 < x < 1$

86435120433. $0 \leq x \leq 1$

86435120434. $0 < x \leq 1$

Question Number : 61 Question Id : 8643516811 Question Type : MCQ Option Shuffling : Yes Is

Question Mandatory : No

Correct Marks : 4 Wrong Marks : 1

اگر تقاضات اس طرح بیان (define) کئے گئے ہیں کہ $f(x) = \sqrt{x}$ اور $g(x) = \sqrt{1-x}$ ، تب مندرجہ ذیل تقاضات کا کیسا ڈومین

(domain) کیا ہوگا۔ $f+g, f-g, f/g, g/f, g-f$

جہاں $(f \pm g)(x) = f(x) \pm g(x), (f/g)(x) = \frac{f(x)}{g(x)}$

Options :

86435120431. $0 \leq x < 1$

86435120432. $0 < x < 1$

86435120433. $0 \leq x \leq 1$

86435120434. $0 < x \leq 1$

Question Number : 62 Question Id : 8643516812 Question Type : MCQ Option Shuffling : Yes Is

Question Mandatory : No

Correct Marks : 4 Wrong Marks : 1

If the equation $a|z|^2 + \overline{\alpha z} + \alpha \overline{z} + d = 0$ represents a circle where a, d are real constants, then which of the following condition is correct ?

Options :

86435120435. $|\alpha|^2 - ad \geq 0$ and $a \in \mathbb{R}$

86435120436. $|\alpha|^2 - ad > 0$ and $a \in \mathbb{R} - \{0\}$

86435120437. $|\alpha|^2 - ad \neq 0$

86435120438. $\alpha = 0, a, d \in \mathbb{R}^+$

Question Number : 62 Question Id : 8643516812 Question Type : MCQ Option Shuffling : Yes Is

Question Mandatory : No

Correct Marks : 4 Wrong Marks : 1

مساوات $a|z|^2 + \bar{\alpha}z + \alpha\bar{z} + d = 0$ ایک دائرہ کی نمائندگی کرتا ہے۔ جہاں a, d حقیقی مستقلات (Constants) ہیں، تب مندرجہ ذیل میں سے کون سی شرط صحیح ہے۔

Options :

86435120435. $a \in \mathbb{R}$ اور $|\alpha|^2 - ad \geq 0$

86435120436. $a \in \mathbb{R} - \{0\}$ اور $|\alpha|^2 - ad > 0$

86435120437. $|\alpha|^2 - ad \neq 0$

86435120438. $\alpha = 0, a, d \in \mathbb{R}^+$

Question Number : 63 Question Id : 8643516813 Question Type : MCQ Option Shuffling : Yes Is

Question Mandatory : No

Correct Marks : 4 Wrong Marks : 1

Let $A + 2B = \begin{bmatrix} 1 & 2 & 0 \\ 6 & -3 & 3 \\ -5 & 3 & 1 \end{bmatrix}$ and $2A - B = \begin{bmatrix} 2 & -1 & 5 \\ 2 & -1 & 6 \\ 0 & 1 & 2 \end{bmatrix}$. If $\text{Tr}(A)$ denotes the sum of all

diagonal elements of the matrix A , then $\text{Tr}(A) - \text{Tr}(B)$ has value equal to :

Options :

86435120439. 1

86435120440. 2

86435120441. 3

86435120442. 0

Question Number : 63 Question Id : 8643516813 Question Type : MCQ Option Shuffling : Yes Is

Question Mandatory : No

Correct Marks : 4 Wrong Marks : 1

$$2A - B = \begin{bmatrix} 2 & -1 & 5 \\ 2 & -1 & 6 \\ 0 & 1 & 2 \end{bmatrix} \text{ اور } A + 2B = \begin{bmatrix} 1 & 2 & 0 \\ 6 & -3 & 3 \\ -5 & 3 & 1 \end{bmatrix} \text{ فرض کیجئے}$$

اگر $\text{Tr}(A) - \text{Tr}(B)$ کی قیمت ہوگی۔

Options :

86435120439. 1

86435120440. 2

86435120441. 3

86435120442. 0

Question Number : 64 Question Id : 8643516814 Question Type : MCQ Option Shuffling : Yes Is Question Mandatory : No

Correct Marks : 4 Wrong Marks : 1

Let α, β, γ be the real roots of the equation, $x^3 + ax^2 + bx + c = 0$, ($a, b, c \in \mathbb{R}$ and $a, b \neq 0$). If the system of equations (in u, v, w) given by $\alpha u + \beta v + \gamma w = 0$; $\beta u + \gamma v + \alpha w = 0$;

$\gamma u + \alpha v + \beta w = 0$ has non-trivial solution, then the value of $\frac{a^2}{b}$ is :

Options :

86435120443. 0

86435120444. 1

86435120445. 3

86435120446. 5

Question Number : 64 Question Id : 8643516814 Question Type : MCQ Option Shuffling : Yes Is Question Mandatory : No

Correct Marks : 4 Wrong Marks : 1

فرض کیجئے مساوات $x^3 + ax^2 + bx + c = 0$, ($a, b \neq 0$ اور $a, b, c \in \mathbb{R}$) کے حقیقی جذر α, β, γ ہیں۔ اگر مساواتوں
 (u, v, w) میں (non-trivial) کا غیر ادنیٰ حل ہوگا۔ جبکہ مساواتوں کا نظام اس طرح ہے۔
 $\alpha u + \beta v + \gamma w = 0$; $\beta u + \gamma v + \alpha w = 0$; $\gamma u + \alpha v + \beta w = 0$ تب $\frac{a^2}{b}$ کی قیمت ہوگی۔

Options :

86435120443. 0

86435120444. 1

86435120445. 3

86435120446. 5

Question Number : 65 Question Id : 8643516815 Question Type : MCQ Option Shuffling : Yes Is Question Mandatory : No

Correct Marks : 4 Wrong Marks : 1

The sum of all the 4-digit distinct numbers that can be formed with the digits 1, 2, 2 and 3 is :

Options :

86435120447. 22264

86435120448. 26664

86435120449. 122234

86435120450. 122664

Question Number : 65 Question Id : 8643516815 Question Type : MCQ Option Shuffling : Yes Is Question Mandatory : No

Correct Marks : 4 Wrong Marks : 1

ہندسوں 1، 2، 2 اور 3 سے بنائے جانے والے 4 ہندسوں کے علیحدہ اعداد کا جوڑ ہوگا۔

Options :

86435120447. 22264

86435120448. 26664

86435120449. 122234

86435120450. 122664

Question Number : 66 Question Id : 8643516816 Question Type : MCQ Option Shuffling : Yes Is Question Mandatory : No

Correct Marks : 4 Wrong Marks : 1

Let $(1 + x + 2x^2)^{20} = a_0 + a_1x + a_2x^2 + \dots + a_{40}x^{40}$. Then, $a_1 + a_3 + a_5 + \dots + a_{37}$ is equal to :

Options :

86435120451. $2^{19}(2^{20} + 21)$

86435120452. $2^{20}(2^{20} + 21)$

86435120453. $2^{19}(2^{20} - 21)$

86435120454. $2^{20}(2^{20} - 21)$

Question Number : 66 Question Id : 8643516816 Question Type : MCQ Option Shuffling : Yes Is Question Mandatory : No

Correct Marks : 4 Wrong Marks : 1

: فرض کیجئے $(1 + x + 2x^2)^{20} = a_0 + a_1x + a_2x^2 + \dots + a_{40}x^{40}$ تب $a_1 + a_3 + a_5 + \dots + a_{37}$ برابر ہوگا :

Options :

86435120451. $2^{19}(2^{20} + 21)$

86435120452. $2^{20}(2^{20} + 21)$

86435120453. $2^{19}(2^{20} - 21)$

86435120454. $2^{20}(2^{20} - 21)$

Question Number : 67 Question Id : 8643516817 Question Type : MCQ Option Shuffling : Yes Is Question Mandatory : No

Correct Marks : 4 Wrong Marks : 1

The value of $3 + \frac{1}{4 + \frac{1}{3 + \frac{1}{4 + \frac{1}{3 + \dots \infty}}}}$ is equal to :

Options :

86435120455. $1.5 + \sqrt{3}$

86435120456. $2 + \sqrt{3}$

86435120457. $3 + 2\sqrt{3}$

86435120458. $4 + \sqrt{3}$

Question Number : 67 Question Id : 8643516817 Question Type : MCQ Option Shuffling : Yes Is Question Mandatory : No

Correct Marks : 4 Wrong Marks : 1

کی قیمت کیا ہوگی۔

$$3 + \frac{1}{4 + \frac{1}{3 + \frac{1}{4 + \frac{1}{3 + \dots \infty}}}}$$

Options :

86435120455. $1.5 + \sqrt{3}$

86435120456. $2 + \sqrt{3}$

86435120457. $3 + 2\sqrt{3}$

86435120458. $4 + \sqrt{3}$

Question Number : 68 Question Id : 8643516818 Question Type : MCQ Option Shuffling : Yes Is Question Mandatory : No

Correct Marks : 4 Wrong Marks : 1

$\frac{1}{3^2 - 1} + \frac{1}{5^2 - 1} + \frac{1}{7^2 - 1} + \dots + \frac{1}{(201)^2 - 1}$ is equal to :

Options :

$$86435120459. \frac{25}{101}$$

$$86435120460. \frac{101}{408}$$

$$86435120461. \frac{99}{400}$$

$$86435120462. \frac{101}{404}$$

Question Number : 68 Question Id : 8643516818 Question Type : MCQ Option Shuffling : Yes Is Question Mandatory : No

Correct Marks : 4 Wrong Marks : 1

$$\frac{1}{3^2 - 1} + \frac{1}{5^2 - 1} + \frac{1}{7^2 - 1} + \dots + \frac{1}{(201)^2 - 1}$$

Options :

$$86435120459. \frac{25}{101}$$

$$86435120460. \frac{101}{408}$$

$$86435120461. \frac{99}{400}$$

$$86435120462. \frac{101}{404}$$

Question Number : 69 Question Id : 8643516819 Question Type : MCQ Option Shuffling : Yes Is Question Mandatory : No

Correct Marks : 4 Wrong Marks : 1

If α, β are natural numbers such that $100^\alpha - 199^\beta = (100)(100) + (99)(101) + (98)(102) + \dots + (1)(199)$, then the slope of the line passing through (α, β) and origin is :

Options :

$$86435120463. 510$$

86435120464. 530

86435120465. 540

86435120466. 550

Question Number : 69 Question Id : 8643516819 Question Type : MCQ Option Shuffling : Yes Is Question Mandatory : No Correct Marks : 4 Wrong Marks : 1

اگر α, β قدرتی اعداد اس طرح کہ $100^\alpha - 199^\beta = (100)(100) + (99)(101) + (98)(102) + \dots + (1)(199)$ تب (α, β) اور مبداء سے گزرنے والے خط کی ڈھلان ہوگی۔

Options :

86435120463. 510

86435120464. 530

86435120465. 540

86435120466. 550

Question Number : 70 Question Id : 8643516820 Question Type : MCQ Option Shuffling : Yes Is Question Mandatory : No Correct Marks : 4 Wrong Marks : 1

If $f(x) = \begin{cases} \frac{1}{|x|} & ; |x| \geq 1 \\ ax^2 + b & ; |x| < 1 \end{cases}$ is differentiable at every point of the domain, then the values of

a and b are respectively :

Options :86435120467. $\frac{1}{2}, \frac{1}{2}$ 86435120468. $-\frac{1}{2}, \frac{3}{2}$

86435120469. $\frac{5}{2}, -\frac{3}{2}$

86435120470. $\frac{1}{2}, -\frac{3}{2}$

Question Number : 70 Question Id : 8643516820 Question Type : MCQ Option Shuffling : Yes Is Question Mandatory : No Correct Marks : 4 Wrong Marks : 1

$$f(x) = \begin{cases} \frac{1}{|x|} & ; |x| \geq 1 \\ ax^2 + b & ; |x| < 1 \end{cases} \text{ اگر}$$

حلقہ (Domain) کے ہر نقطہ پر تفریق پزیر اور مسلسل ہے تب a اور b کی قیمت ہوگی۔

Options :

86435120467. $\frac{1}{2}, \frac{1}{2}$

86435120468. $-\frac{1}{2}, \frac{3}{2}$

86435120469. $\frac{5}{2}, -\frac{3}{2}$

86435120470. $\frac{1}{2}, -\frac{3}{2}$

Question Number : 71 Question Id : 8643516821 Question Type : MCQ Option Shuffling : Yes Is Question Mandatory : No Correct Marks : 4 Wrong Marks : 1

The real valued function $f(x) = \frac{\operatorname{cosec}^{-1}x}{\sqrt{x - [x]}}$, where $[x]$ denotes the greatest integer less than or

equal to x , is defined for all x belonging to :

Options :

86435120471. all reals except integers

86435120472. all reals except the interval $[-1, 1]$

86435120473. all non-integers except the interval $[-1, 1]$

86435120474. all integers except 0, -1, 1

Question Number : 71 Question Id : 8643516821 Question Type : MCQ Option Shuffling : Yes Is Question Mandatory : No

Correct Marks : 4 Wrong Marks : 1

$$\text{حقیقی عدد } x \text{ تعلق } f(x) = \frac{\operatorname{cosec}^{-1} x}{\sqrt{x - [x]}} \text{ فرض کیجئے۔}$$

(Define) جہاں $[x]$ سب سے بڑا صحیح عدد (Integer) جو x سے چھوٹا ہے اس کے برابر ہے، یہ تعلق x کی ساری قیمتوں کے لئے معرف (Define) ہے، جہاں پر x متعلق (belong) ہے۔

Options :

86435120471. سارے حقیقی اعداد سوائے صحیح اعداد سے

86435120472. سارے حقیقی اعداد سے سوائے وقفہ $[-1, 1]$ میں۔

86435120473. سارے غیر صحیح اعداد سے سوائے وقفہ $[-1, 1]$ میں۔

86435120474. سارے صحیح اعداد سے سوائے 0, -1, 1 کے

Question Number : 72 Question Id : 8643516822 Question Type : MCQ Option Shuffling : Yes Is Question Mandatory : No

Correct Marks : 4 Wrong Marks : 1

If $\lim_{x \rightarrow 0} \frac{\sin^{-1} x - \tan^{-1} x}{3x^3}$ is equal to L, then the value of $(6L + 1)$ is :

Options :

86435120475. $\frac{1}{6}$

86435120476. 6

86435120477. 2

86435120478. $\frac{1}{2}$

Question Number : 72 Question Id : 8643516822 Question Type : MCQ Option Shuffling : Yes Is Question Mandatory : No

Correct Marks : 4 Wrong Marks : 1

اگر $\lim_{x \rightarrow 0} \frac{\sin^{-1} x - \tan^{-1} x}{3x^3} = L$ ، کہ برابر ہے۔ تب $(6L + 1)$ کی قیمت ہوگی۔

Options :

86435120475. $\frac{1}{6}$

86435120476. 6

86435120477. 2

86435120478. $\frac{1}{2}$

Question Number : 73 Question Id : 8643516823 Question Type : MCQ Option Shuffling : Yes Is Question Mandatory : No

Correct Marks : 4 Wrong Marks : 1

The integral $\int \frac{(2x - 1) \cos \sqrt{(2x - 1)^2 + 5}}{\sqrt{4x^2 - 4x + 6}} dx$ is equal to :

(where c is a constant of integration)

Options :

86435120479. $\frac{1}{2} \sin \sqrt{(2x + 1)^2 + 5} + c$

86435120480. $\frac{1}{2} \sin \sqrt{(2x - 1)^2 + 5} + c$

86435120481. $\frac{1}{2} \cos \sqrt{(2x - 1)^2 + 5} + c$

86435120482. $\frac{1}{2} \cos \sqrt{(2x+1)^2 + 5} + c$

Question Number : 73 Question Id : 8643516823 Question Type : MCQ Option Shuffling : Yes Is Question Mandatory : No

Correct Marks : 4 Wrong Marks : 1

مندرجہ ذیل میں کس کے برابر ہے ؟ $\int \frac{(2x-1) \cos \sqrt{(2x-1)^2 + 5}}{\sqrt{4x^2 - 4x + 6}} dx$ تکملہ
(جہاں پر c تکمیل کا مستقلہ ہے۔)

Options :

86435120479. $\frac{1}{2} \sin \sqrt{(2x+1)^2 + 5} + c$

86435120480. $\frac{1}{2} \sin \sqrt{(2x-1)^2 + 5} + c$

86435120481. $\frac{1}{2} \cos \sqrt{(2x-1)^2 + 5} + c$

86435120482. $\frac{1}{2} \cos \sqrt{(2x+1)^2 + 5} + c$

Question Number : 74 Question Id : 8643516824 Question Type : MCQ Option Shuffling : Yes Is Question Mandatory : No

Correct Marks : 4 Wrong Marks : 1

The differential equation satisfied by the system of parabolas $y^2 = 4a(x+a)$ is :

Options :

86435120483. $y \left(\frac{dy}{dx} \right)^2 + 2x \left(\frac{dy}{dx} \right) - y = 0$

86435120484. $y \left(\frac{dy}{dx} \right) + 2x \left(\frac{dy}{dx} \right) - y = 0$

86435120485. $y \left(\frac{dy}{dx} \right)^2 - 2x \left(\frac{dy}{dx} \right) + y = 0$

86435120486. $y\left(\frac{dy}{dx}\right)^2 - 2x\left(\frac{dy}{dx}\right) - y = 0$

Question Number : 74 Question Id : 8643516824 Question Type : MCQ Option Shuffling : Yes Is Question Mandatory : No

Correct Marks : 4 Wrong Marks : 1

تفرقی مساوات جس کو مکافیوں کا نظام $y^2 = 4a(x + a)$ مطمئن کرتا ہے، ہوگی

Options :

86435120483. $y\left(\frac{dy}{dx}\right)^2 + 2x\left(\frac{dy}{dx}\right) - y = 0$

86435120484. $y\left(\frac{dy}{dx}\right) + 2x\left(\frac{dy}{dx}\right) - y = 0$

86435120485. $y\left(\frac{dy}{dx}\right)^2 - 2x\left(\frac{dy}{dx}\right) + y = 0$

86435120486. $y\left(\frac{dy}{dx}\right)^2 - 2x\left(\frac{dy}{dx}\right) - y = 0$

Question Number : 75 Question Id : 8643516825 Question Type : MCQ Option Shuffling : Yes Is Question Mandatory : No

Correct Marks : 4 Wrong Marks : 1

Choose the correct statement about two circles whose equations are given below :

$$x^2 + y^2 - 10x - 10y + 41 = 0$$

$$x^2 + y^2 - 22x - 10y + 137 = 0$$

Options :

86435120487. circles have two meeting points

86435120488. circles have no meeting point

86435120489. circles have only one meeting point

86435120490. circles have same centre

Question Number : 75 Question Id : 8643516825 Question Type : MCQ Option Shuffling : Yes Is

Question Mandatory : No

Correct Marks : 4 Wrong Marks : 1

دو دائروں، کے بارے میں صحیح بیان کا انتخاب کیجئے، جن کی مساواتیں اس طرح ہیں۔

$$x^2 + y^2 - 10x - 10y + 41 = 0$$

$$x^2 + y^2 - 22x - 10y + 137 = 0$$

Options :

86435120487. دائرے دو نقاط پر ملتے ہیں۔

86435120488. دائرے بھی ایک دوسرے سے نہیں ملتے ہیں۔

86435120489. دائرے صرف ایک نقطہ پر ملتے ہیں۔

86435120490. دائروں کا مرکز ایک ہی ہے۔

Question Number : 76 Question Id : 8643516826 Question Type : MCQ Option Shuffling : Yes Is

Question Mandatory : No

Correct Marks : 4 Wrong Marks : 1

For the four circles M, N, O and P, following four equations are given :

Circle M : $x^2 + y^2 = 1$

Circle N : $x^2 + y^2 - 2x = 0$

Circle O : $x^2 + y^2 - 2x - 2y + 1 = 0$

Circle P : $x^2 + y^2 - 2y = 0$

If the centre of circle M is joined with centre of the circle N, further centre of circle N is joined with centre of the circle O, centre of circle O is joined with the centre of circle P and lastly, centre of circle P is joined with centre of circle M, then these lines form the sides of a :

Options :

86435120491. Rectangle

86435120492. Rhombus

86435120493. Square

86435120494. Parallelogram

Question Number : 76 Question Id : 8643516826 Question Type : MCQ Option Shuffling : Yes Is

Question Mandatory : No

Correct Marks : 4 Wrong Marks : 1

چار دائروں M، N، O اور P کے لئے چار مساواتیں دی گئی ہیں۔

$$x^2 + y^2 = 1 \quad : \text{ M دائرہ}$$

$$x^2 + y^2 - 2x = 0 \quad : \text{ N دائرہ}$$

$$x^2 + y^2 - 2x - 2y + 1 = 0 \quad : \text{ O دائرہ}$$

$$x^2 + y^2 - 2y = 0 \quad : \text{ P دائرہ}$$

اگر دائرہ M کا مرکز، دائرہ N سے جڑا ہوا ہے، اور دائرہ N کا مرکز دائرہ O سے جڑا ہوا ہے، دائرہ O کا مرکز دائرہ P سے جڑا ہوا ہے اور آخر میں دائرہ P کا مرکز دائرہ M سے جڑا ہوا ہے۔ تب یہ خطوط (Lines) کس کے اضلاع (Sides) ہیں۔

Options :

86435120491. (Rectangle) مستطیل

86435120492. (Rhombus) تشکل معین

86435120493. (Square) مربع

86435120494. (Parallelogram) متوازی الاضلاع

Question Number : 77 Question Id : 8643516827 Question Type : MCQ Option Shuffling : Yes Is

Question Mandatory : No

Correct Marks : 4 Wrong Marks : 1

The number of integral values of m so that the abscissa of point of intersection of lines $3x + 4y = 9$ and $y = mx + 1$ is also an integer, is :

Options :

86435120495. 0

86435120496. 1

86435120497. 2

86435120498. 3

Question Number : 77 Question Id : 8643516827 Question Type : MCQ Option Shuffling : Yes Is
Question Mandatory : No
Correct Marks : 4 Wrong Marks : 1

M کی صحیح عددی قیمتوں کی تعداد کتنی ہوگی جبکہ خطوط $y = mx + 1$ اور $3x + 4y = 9$ (lines) کے تقاطع کا فاصلہ (abscissa) بھی ایک صحیح عدد (integer) ہے۔

Options :

86435120495. 0

86435120496. 1

86435120497. 2

86435120498. 3

Question Number : 78 Question Id : 8643516828 Question Type : MCQ Option Shuffling : Yes Is
Question Mandatory : No
Correct Marks : 4 Wrong Marks : 1

The equation of one of the straight lines which passes through the point (1, 3) and makes an angle $\tan^{-1}(\sqrt{2})$ with the straight line, $y + 1 = 3\sqrt{2}x$ is :

Options :86435120499. $4\sqrt{2}x + 5y - (15 + 4\sqrt{2}) = 0$ 86435120500. $4\sqrt{2}x - 5y - (5 + 4\sqrt{2}) = 0$ 86435120501. $5\sqrt{2}x + 4y - (15 + 4\sqrt{2}) = 0$ 86435120502. $4\sqrt{2}x + 5y - 4\sqrt{2} = 0$

Question Number : 78 Question Id : 8643516828 Question Type : MCQ Option Shuffling : Yes Is
Question Mandatory : No
Correct Marks : 4 Wrong Marks : 1

اس سیدھی خط کی مساوات بتائیں، جو نقطہ (1, 3) گزرتی ہے اور سیدھی خط $y + 1 = 3\sqrt{2}x$ کے ساتھ $\tan^{-1}(\sqrt{2})$ کا زاویہ بناتی ہے۔

- ہے

Options :

86435120499. $4\sqrt{2}x + 5y - (15 + 4\sqrt{2}) = 0$

86435120500. $4\sqrt{2}x - 5y - (5 + 4\sqrt{2}) = 0$

86435120501. $5\sqrt{2}x + 4y - (15 + 4\sqrt{2}) = 0$

86435120502. $4\sqrt{2}x + 5y - 4\sqrt{2} = 0$

Question Number : 79 Question Id : 8643516829 Question Type : MCQ Option Shuffling : Yes Is Question Mandatory : No

Correct Marks : 4 Wrong Marks : 1

The solutions of the equation

$$\begin{vmatrix} 1 + \sin^2 x & \sin^2 x & \sin^2 x \\ \cos^2 x & 1 + \cos^2 x & \cos^2 x \\ 4 \sin 2x & 4 \sin 2x & 1 + 4 \sin 2x \end{vmatrix} = 0, (0 < x < \pi), \text{ are :}$$

Options :

86435120503. $\frac{\pi}{6}, \frac{5\pi}{6}$

86435120504. $\frac{5\pi}{12}, \frac{7\pi}{12}$

86435120505. $\frac{7\pi}{12}, \frac{11\pi}{12}$

86435120506. $\frac{\pi}{12}, \frac{\pi}{6}$

Question Number : 79 Question Id : 8643516829 Question Type : MCQ Option Shuffling : Yes Is Question Mandatory : No

Correct Marks : 4 Wrong Marks : 1

$$\begin{vmatrix} 1 + \sin^2 x & \sin^2 x & \sin^2 x \\ \cos^2 x & 1 + \cos^2 x & \cos^2 x \\ 4 \sin 2x & 4 \sin 2x & 1 + 4 \sin 2x \end{vmatrix} = 0, (0 < x < \pi) \text{ مساوات}$$

کے حل (solution) ہونگے

Options :

86435120503. $\frac{\pi}{6}, \frac{5\pi}{6}$

86435120504. $\frac{5\pi}{12}, \frac{7\pi}{12}$

86435120505. $\frac{7\pi}{12}, \frac{11\pi}{12}$

86435120506. $\frac{\pi}{12}, \frac{\pi}{6}$

Question Number : 80 Question Id : 8643516830 Question Type : MCQ Option Shuffling : Yes Is Question Mandatory : No

Correct Marks : 4 Wrong Marks : 1

A vector \vec{a} has components $3p$ and 1 with respect to a rectangular cartesian system. This system is rotated through a certain angle about the origin in the counter clockwise sense. If, with respect to new system, \vec{a} has components $p + 1$ and $\sqrt{10}$, then a value of p is equal to :

Options :

86435120507. 1

86435120508. -1

86435120509. $\frac{4}{5}$

86435120510. $-\frac{5}{4}$

Question Number : 80 Question Id : 8643516830 Question Type : MCQ Option Shuffling : Yes Is

Question Mandatory : No

Correct Marks : 4 Wrong Marks : 1

اگر سمتیہ \vec{a} کے مستطیلی کارٹیسین نظام (rectangular cartesian system) کی نسبت سے عناصر $3p$ (components) اور 1 ہیں۔

اس نظام کو گھڑی کی مخالف سمت (counter clockwise) میں ایک خاص زاویہ سے گھمایا جاتا ہے۔ اگر نئے نظام کی نسبت سے \vec{a} کے عناصر $p+1$ اور $\sqrt{10}$ ہیں، تب p کس کے برابر ہوگا۔

Options :

86435120507. 1

86435120508. -1

86435120509. $\frac{4}{5}$

86435120510. $-\frac{5}{4}$

Mathematics Section B

Section Id :	864351456
Section Number :	6
Section type :	Online
Mandatory or Optional :	Mandatory
Number of Questions :	10
Number of Questions to be attempted :	5
Section Marks :	20
Mark As Answered Required? :	Yes
Sub-Section Number :	1
Sub-Section Id :	864351456
Question Shuffling Allowed :	Yes

Question Number : 81 Question Id : 8643516831 Question Type : SA

Correct Marks : 4 Wrong Marks : 0

Let z_1, z_2 be the roots of the equation $z^2 + az + 12 = 0$ and z_1, z_2 form an equilateral triangle with origin. Then, the value of $|a|$ is _____.

Response Type : Numeric

Evaluation Required For SA : Yes

Show Word Count : Yes

Answers Type : Equal

Text Areas : PlainText

Possible Answers :

100

Question Number : 81 Question Id : 8643516831 Question Type : SA

Correct Marks : 4 Wrong Marks : 0

فرض کیجئے کہ مساوات $z^2 + az + 12 = 0$ کے جذر z_1, z_2 ہیں۔ اور z_2, z_1 مبداء کے ساتھ مساوی الاضلاع (Equilateral triangle) مثلث بناتے ہیں۔ تب $|a|$ کی قیمت ہوگی _____۔

Response Type : Numeric

Evaluation Required For SA : Yes

Show Word Count : Yes

Answers Type : Equal

Text Areas : PlainText

Possible Answers :

100

Question Number : 82 Question Id : 8643516832 Question Type : SA

Correct Marks : 4 Wrong Marks : 0

Let $f(x)$ and $g(x)$ be two functions satisfying $f(x^2) + g(4-x) = 4x^3$ and $g(4-x) + g(x) = 0$, then

the value of $\int_{-4}^4 f(x^2) dx$ is _____.

Response Type : Numeric

Evaluation Required For SA : Yes

Show Word Count : Yes

Answers Type : Equal

Text Areas : PlainText

Possible Answers :

100

Question Number : 82 Question Id : 8643516832 Question Type : SA

Correct Marks : 4 Wrong Marks : 0

فرض کیجئے کہ $f(x)$ اور $g(x)$ دو تفاعلات ہیں جو $f(x^2) + g(4-x) = 4x^3$ اور $g(4-x) + g(x) = 0$ کو مطمئن کرتے ہیں، تب $\int_{-4}^4 f(x^2) dx$ کی قیمت ہوگی _____۔

Response Type : Numeric

Evaluation Required For SA : Yes

Show Word Count : Yes

Answers Type : Equal

Text Areas : PlainText

Possible Answers :

100

Question Number : 83 Question Id : 8643516833 Question Type : SA

Correct Marks : 4 Wrong Marks : 0

If $f(x) = \int \frac{5x^8 + 7x^6}{(x^2 + 1 + 2x^7)^2} dx$, ($x \geq 0$), $f(0) = 0$ and $f(1) = \frac{1}{K}$, then the value of K is

_____.

Response Type : Numeric

Evaluation Required For SA : Yes

Show Word Count : Yes

Answers Type : Equal

Text Areas : PlainText

Possible Answers :

100

Question Number : 83 Question Id : 8643516833 Question Type : SA

Correct Marks : 4 Wrong Marks : 0

اگر $f(0) = 0$, ($x \geq 0$) اور $f(x) = \int \frac{5x^8 + 7x^6}{(x^2 + 1 + 2x^7)^2} dx$ اور $f(1) = \frac{1}{K}$ ہے تب K کی قیمت _____ ہوگی۔

Response Type : Numeric

Evaluation Required For SA : Yes

Show Word Count : Yes

Answers Type : Equal

Text Areas : PlainText

Possible Answers :

100

Question Number : 84 Question Id : 8643516834 Question Type : SA

Correct Marks : 4 Wrong Marks : 0

A square ABCD has all its vertices on the curve $x^2y^2 = 1$. The midpoints of its sides also lie on the same curve. Then, the square of area of ABCD is _____.

Response Type : Numeric

Evaluation Required For SA : Yes

Show Word Count : Yes

Answers Type : Equal

Text Areas : PlainText

Possible Answers :

100

Question Number : 84 Question Id : 8643516834 Question Type : SA

Correct Marks : 4 Wrong Marks : 0

ایک مربع ABCD کی چاروں راسیں منحنی $x^2 + y^2 = 1$ پر ہیں۔ اس کے اضلاع کے درمیانی نقاط بھی اس منحنی پر واقعہ ہیں۔ تب ABCD کے رقبہ کا مربع ہوگا _____۔

Response Type : Numeric

Evaluation Required For SA : Yes

Show Word Count : Yes

Answers Type : Equal

Text Areas : PlainText

Possible Answers :

100

Question Number : 85 Question Id : 8643516835 Question Type : SA

Correct Marks : 4 Wrong Marks : 0

Let the plane $ax + by + cz + d = 0$ bisect the line joining the points $(4, -3, 1)$ and $(2, 3, -5)$ at the right angles. If a, b, c, d are integers, then the minimum value of $(a^2 + b^2 + c^2 + d^2)$ is _____.

Response Type : Numeric

Evaluation Required For SA : Yes

Show Word Count : Yes

Answers Type : Equal

Text Areas : PlainText

Possible Answers :

100

Question Number : 85 Question Id : 8643516835 Question Type : SA

Correct Marks : 4 Wrong Marks : 0

اگر مستوی $ax + by + cz + d = 0$ ، نقاط $(4, -3, 1)$ اور $(2, 3, -5)$ کو ملا کر بننے والی خط کو عمود زاویہ پر تنصیف کرتا ہے۔ تب $(a^2 + b^2 + c^2 + d^2)$ کی سب سے کم قیمت کیا ہوگی۔ اگر a, b, c, d صحیح عدد ہیں _____۔

Response Type : Numeric

Evaluation Required For SA : Yes

Show Word Count : Yes

Answers Type : Equal

Text Areas : PlainText

Possible Answers :

100

Question Number : 86 Question Id : 8643516836 Question Type : SA

Correct Marks : 4 Wrong Marks : 0

The equation of the planes parallel to the plane $x - 2y + 2z - 3 = 0$ which are at unit distance from the point $(1, 2, 3)$ is $ax + by + cz + d = 0$. If $(b - d) = K(c - a)$, then the positive value of K is _____.

Response Type : Numeric

Evaluation Required For SA : Yes

Show Word Count : Yes

Answers Type : Equal

Text Areas : PlainText

Possible Answers :

100

Question Number : 86 Question Id : 8643516836 Question Type : SA

Correct Marks : 4 Wrong Marks : 0

ایک ایسے مستوی (plane) کی مساوات ہے، جو مستوی $x - 2y + 2z - 3 = 0$ کے متوازی ہے، اور نقطہ $(1, 2, 3)$ سے اکائی دوری پر ہے۔ اگر $(b - d) = K(c - a)$ تب K کی مثبت قیمت ہوگی _____۔

Response Type : Numeric

Evaluation Required For SA : Yes

Show Word Count : Yes

Answers Type : Equal

Text Areas : PlainText

Possible Answers :

100

Question Number : 87 Question Id : 8643516837 Question Type : SA

Correct Marks : 4 Wrong Marks : 0

The mean age of 25 teachers in a school is 40 years. A teacher retires at the age of 60 years and a new teacher is appointed in his place. If the mean age of the teachers in this school now is 39 years, then the age (in years) of the newly appointed teacher is _____.

Response Type : Numeric

Evaluation Required For SA : Yes

Show Word Count : Yes

Answers Type : Equal

Text Areas : PlainText

Possible Answers :

100

Question Number : 87 Question Id : 8643516837 Question Type : SA

Correct Marks : 4 Wrong Marks : 0

ایک اسکول میں 25 اساتذہ کی درمیانہ عمر 40 سال ہے اگر ایک استاد 60 سال کی عمر میں ریٹائر ہوتا ہے۔ اور اس کی جگہ ایک نیا استاد مقرر ہوتا ہے۔
اگر اب اسکول میں اساتذہ کی درمیانہ عمر 39 ہے۔ تب نئے آنے والے استاد کی عمر ہوگی _____۔

Response Type : Numeric

Evaluation Required For SA : Yes

Show Word Count : Yes

Answers Type : Equal

Text Areas : PlainText

Possible Answers :

100

Question Number : 88 Question Id : 8643516838 Question Type : SA

Correct Marks : 4 Wrong Marks : 0

The number of times the digit 3 will be written when listing the integers from 1 to 1000 is _____.

Response Type : Numeric

Evaluation Required For SA : Yes

Show Word Count : Yes

Answers Type : Equal

Text Areas : PlainText

Possible Answers :

100

Question Number : 88 Question Id : 8643516838 Question Type : SA

Correct Marks : 4 Wrong Marks : 0

1 سے 1000 تک صحیح عدد کو شمار کرتے ہوئے ہندسہ 3 کتنی مرتبہ لکھا جائے گا ؟ _____

Response Type : Numeric

Evaluation Required For SA : Yes

Show Word Count : Yes

Answers Type : Equal

Text Areas : PlainText

Possible Answers :

100

Question Number : 89 Question Id : 8643516839 Question Type : SA

Correct Marks : 4 Wrong Marks : 0

The missing value in the following figure is _____.

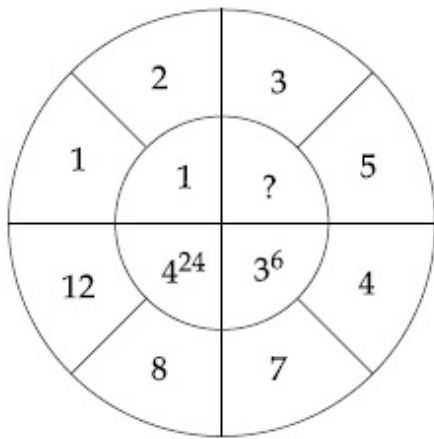

Response Type : Numeric

Evaluation Required For SA : Yes

Show Word Count : Yes

Answers Type : Equal

Text Areas : PlainText

Possible Answers :

100

Question Number : 89 **Question Id :** 8643516839 **Question Type :** SA

Correct Marks : 4 **Wrong Marks :** 0

_____ نیچے دی گئی شکل میں غائب قیمت ہوگی

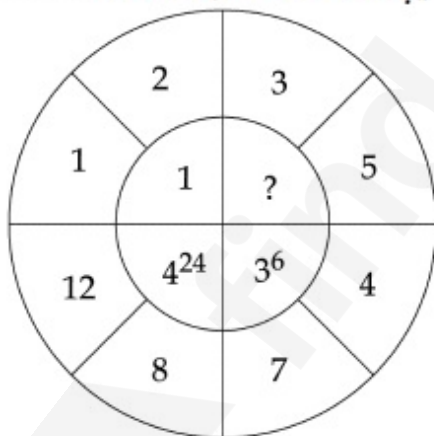

Response Type : Numeric

Evaluation Required For SA : Yes

Show Word Count : Yes

Answers Type : Equal

Text Areas : PlainText

Possible Answers :

100

Question Number : 90 **Question Id :** 8643516840 **Question Type :** SA

Correct Marks : 4 **Wrong Marks :** 0

The number of solutions of the equation $|\cot x| = \cot x + \frac{1}{\sin x}$ in the interval $[0, 2\pi]$ is

_____.

Response Type : Numeric

Evaluation Required For SA : Yes

Show Word Count : Yes

Answers Type : Equal

Text Areas : PlainText

Possible Answers :

100

Question Number : 90 **Question Id :** 8643516840 **Question Type :** SA

Correct Marks : 4 **Wrong Marks :** 0

_____ مساوات $|\cot x| = \cot x + \frac{1}{\sin x}$ کے وقفہ $[0, 2\pi]$ میں حلوں (solution) کی تعداد ہوگی۔

Response Type : Numeric

Evaluation Required For SA : Yes

Show Word Count : Yes

Answers Type : Equal

Text Areas : PlainText

Possible Answers :

100