

<b>Question Paper Name :</b>	B TECH EO 25th Feb 2021 Shift 1
<b>Subject Name :</b>	B TECH EO
<b>Creation Date :</b>	2021-02-24 14:14:27
<b>Duration :</b>	180
<b>Number of Questions :</b>	90
<b>Total Marks :</b>	300
<b>Display Marks:</b>	Yes

## B TECH EO

<b>Group Number :</b>	1
<b>Group Id :</b>	708191197
<b>Group Maximum Duration :</b>	0
<b>Group Minimum Duration :</b>	180
<b>Show Attended Group? :</b>	No
<b>Edit Attended Group? :</b>	No
<b>Break time :</b>	0
<b>Group Marks :</b>	300
<b>Is this Group for Examiner? :</b>	No

## Physics Section A

<b>Section Id :</b>	708191760
<b>Section Number :</b>	1
<b>Section type :</b>	Online

Mandatory or Optional :	Mandatory
Number of Questions :	20
Number of Questions to be attempted :	20
Section Marks :	80
Mark As Answered Required? :	Yes
Sub-Section Number :	1
Sub-Section Id :	7081911040
Question Shuffling Allowed :	Yes

Question Number : 1 Question Id : 70819118304 Question Type : MCQ Option Shuffling : Yes Is

Question Mandatory : No

Correct Marks : 4 Wrong Marks : 1

Given below are two statements : one is labelled as Assertion A and the other is labelled as Reason R.

Assertion A : The escape velocities of planet A and B are same. But A and B are of unequal mass.

Reason R : The product of their mass and radius must be same.  $M_1R_1 = M_2R_2$

In the light of the above statements, choose the most appropriate answer from the options given below :

Options :

70819160061. Both A and R are correct and R is the correct explanation of A

70819160062. Both A and R are correct but R is NOT the correct explanation of A

70819160063. A is correct but R is not correct

70819160064. A is not correct but R is correct

Question Number : 1 Question Id : 70819118304 Question Type : MCQ Option Shuffling : Yes Is

Question Mandatory : No

Correct Marks : 4 Wrong Marks : 1

ନିମ୍ନରେ ଦୁଇଟି ଉକ୍ତି ଦିଆଯାଇଛି । ଗୋଟିଏ ଘୋଷଣା A ଓ ଅନ୍ୟଟି କାରଣ ଆକାରରେ ଚିହ୍ନିତ ହୋଇଛି ।  
 ଘୋଷଣା A : ଗ୍ରହ A ଏବଂ B ର ପରିନିର୍ଗମନ ପରିବେଶ ସମାନ ଅଟେ । କିନ୍ତୁ A ଓ R ର ଅସମାନ ବସ୍ତୁତ୍ତ୍ୱ ରହିଛି ।

କାରଣ R : ସେମାନଙ୍କର ବସ୍ତୁତ୍ତ୍ୱ ଏବଂ ବ୍ୟାସାର୍ଦ୍ଧର ଗୁଣଫଳ ନିଶ୍ଚିତ ସମାନ

$$M_1 R_1 = M_2 R_2$$

ଉପରୋକ୍ତ ଉକ୍ତି ଅନୁସାରେ, ନିମ୍ନରେ ଦତ୍ତ ବିକଳ୍ପ ଗୁଡ଼ିକରୁ ସର୍ବୋତ୍ତମ ଉତ୍ତର ଚୟନ କର :

**Options :**

70819160061. ଉଭୟ A ଏବଂ R ଠିକ୍ ଏବଂ R ହେଉଛି A ର ଠିକ୍ ବ୍ୟାଖ୍ୟା ।

70819160062. ଉଭୟ A ଏବଂ R ଠିକ୍ କିନ୍ତୁ R, A ର ଠିକ୍ ବ୍ୟାଖ୍ୟା ନୁହେଁ ।

70819160063. A ଠିକ୍ ଅଟେ କିନ୍ତୁ R ଠିକ୍ ନୁହେଁ ।

70819160064. A ଠିକ୍ ନୁହେଁ କିନ୍ତୁ R ଠିକ୍ ଅଟେ ।

**Question Number : 2 Question Id : 70819118305 Question Type : MCQ Option Shuffling : Yes Is Question Mandatory : No**

**Correct Marks : 4 Wrong Marks : 1**

Match List - I with List - II :

**List - I**

**List - II**

- |                            |                              |
|----------------------------|------------------------------|
| (a) h (Planck's constant)  | (i) $[M L T^{-1}]$           |
| (b) E (kinetic energy)     | (ii) $[M L^2 T^{-1}]$        |
| (c) V (electric potential) | (iii) $[M L^2 T^{-2}]$       |
| (d) P (linear momentum)    | (iv) $[M L^2 I^{-1} T^{-3}]$ |

Choose the correct answer from the options given below :

**Options :**

70819160065. (a) → (i), (b) → (ii), (c) → (iv), (d) → (iii)

70819160066. (a) → (iii), (b) → (iv), (c) → (ii), (d) → (i)

70819160067. (a) → (ii), (b) → (iii), (c) → (iv), (d) → (i)

70819160068. (a) → (iii), (b) → (ii), (c) → (iv), (d) → (i)

Question Number : 2 Question Id : 70819118305 Question Type : MCQ Option Shuffling : Yes Is Question Mandatory : No

Correct Marks : 4 Wrong Marks : 1

ତାଲିକା I ସହ ତାଲିକା II କୁ ମିଳାଅ :

ତାଲିକା - I	ତାଲିକା - II
(a) h (ପ୍ଲାଙ୍କ ଧ୍ରୁବାଙ୍କ)	(i) $[M L T^{-1}]$
(b) E (ଗତିଜ ଶକ୍ତି)	(ii) $[M L^2 T^{-1}]$
(c) V (ବୈଦ୍ୟୁତିକ ବିଭବ)	(iii) $[M L^2 T^{-2}]$
(d) P (ରେଖିତ୍ୱ ସଂବେଗ)	(iv) $[M L^2 I^{-1} T^{-3}]$

ତଳେ ଦିଆଯାଇଥିବା ବିକଳ୍ପ ଗୁଡ଼ିକରୁ ଠିକ୍ ଉତ୍ତର ବାଛି :

Options :

70819160065. (a)  $\rightarrow$  (i), (b)  $\rightarrow$  (ii), (c)  $\rightarrow$  (iv), (d)  $\rightarrow$  (iii)

70819160066. (a)  $\rightarrow$  (iii), (b)  $\rightarrow$  (iv), (c)  $\rightarrow$  (ii), (d)  $\rightarrow$  (i)

70819160067. (a)  $\rightarrow$  (ii), (b)  $\rightarrow$  (iii), (c)  $\rightarrow$  (iv), (d)  $\rightarrow$  (i)

70819160068. (a)  $\rightarrow$  (iii), (b)  $\rightarrow$  (ii), (c)  $\rightarrow$  (iv), (d)  $\rightarrow$  (i)

Question Number : 3 Question Id : 70819118306 Question Type : MCQ Option Shuffling : Yes Is Question Mandatory : No

Correct Marks : 4 Wrong Marks : 1

If the time period of a two meter long simple pendulum is 2 s, the acceleration due to gravity at the place where pendulum is executing S.H.M. is :

Options :

70819160069.  $16 \text{ m/s}^2$

70819160070.  $\pi^2 \text{ ms}^{-2}$

70819160071.  $9.8 \text{ ms}^{-2}$

70819160072.  $2\pi^2 \text{ ms}^{-2}$

**Question Number : 3 Question Id : 70819118306 Question Type : MCQ Option Shuffling : Yes Is**

**Question Mandatory : No**

**Correct Marks : 4 Wrong Marks : 1**

ଯଦି ଦୁଇ ମିଟର ଲମ୍ବର ସରଳ ପେଣ୍ଡୁଲମ୍ ଥିବା ବାଦ୍ୟକାଳ 2 s, ଯେଉଁଠାରେ ପେଣ୍ଡୁଲମ୍ ସରଳ ହାରମୋନିକ୍ ଗତି ସମ୍ପାଦନ କରୁଅଛି, ସେଠାରେ ମାଧ୍ୟକର୍ଷଣଜନିତ ତ୍ୱରଣ \_\_\_\_\_ ଅଟେ ।

**Options :**

70819160069.  $16 \text{ m/s}^2$

70819160070.  $\pi^2 \text{ ms}^{-2}$

70819160071.  $9.8 \text{ ms}^{-2}$

70819160072.  $2\pi^2 \text{ ms}^{-2}$

**Question Number : 4 Question Id : 70819118307 Question Type : MCQ Option Shuffling : Yes Is**

**Question Mandatory : No**

**Correct Marks : 4 Wrong Marks : 1**

A student is performing the experiment of resonance column. The diameter of the column tube is 6 cm. The frequency of the tuning fork is 504 Hz. Speed of the sound at the given temperature is 336 m/s. The zero of the metre scale coincides with the top end of the resonance column tube. The reading of the water level in the column when the first resonance occurs is:

**Options :**

70819160073. 16.6 cm

70819160074. 18.4 cm

70819160075. 14.8 cm

70819160076. 13 cm

**Question Number : 4 Question Id : 70819118307 Question Type : MCQ Option Shuffling : Yes Is Question Mandatory : No**

**Correct Marks : 4 Wrong Marks : 1**

ଜଣେ ଛାତ୍ର ଅନୁନାଦ ସ୍ତମ୍ଭ ସମ୍ବନ୍ଧରେ ପରୀକ୍ଷା କରୁଛନ୍ତି । ସ୍ତମ୍ଭ ଚିତ୍ତୁର ବ୍ୟାସ 6 cm ଅଟେ । ଚିତ୍ତୁରିକ୍ ପ୍ରକର ଆବୃତ୍ତି 504 Hz ଅଟେ । ଦୂର ତାପମାତ୍ରାରେ ଶବ୍ଦର ବେଗ 336 m/s ଅଟେ । ଅନୁନାଦ ସ୍ତମ୍ଭ ଚିତ୍ତୁର ଉପର ମୁଣ୍ଡକୁ ମିଶର ଷ୍ଟେଲର ଶୂନ(କିରୋ) ମିଶିଛି । ପ୍ରଥମ ଅନୁନାଦ ହେଉଥିବା ସମୟରେ ସ୍ତମ୍ଭରେ ଥିବା ଜଳ ସ୍ତରର ପଠନ(ରିଡିଙ୍ଗ୍) ହେଉଛି \_\_\_\_\_ ।

**Options :**

70819160073. 16.6 cm

70819160074. 18.4 cm

70819160075. 14.8 cm

70819160076. 13 cm

**Question Number : 5 Question Id : 70819118308 Question Type : MCQ Option Shuffling : Yes Is Question Mandatory : No**

**Correct Marks : 4 Wrong Marks : 1**

In an octagon ABCDEFGH of equal side, what is the sum of

$$\vec{AB} + \vec{AC} + \vec{AD} + \vec{AE} + \vec{AF} + \vec{AG} + \vec{AH},$$

if,  $\vec{AO} = 2\hat{i} + 3\hat{j} - 4\hat{k}$

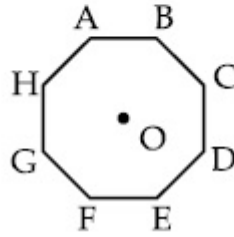

Options :

70819160077.  $16\hat{i} + 24\hat{j} + 32\hat{k}$

70819160078.  $-16\hat{i} - 24\hat{j} + 32\hat{k}$

70819160079.  $16\hat{i} - 24\hat{j} + 32\hat{k}$

70819160080.  $16\hat{i} + 24\hat{j} - 32\hat{k}$

Question Number : 5 Question Id : 70819118308 Question Type : MCQ Option Shuffling : Yes Is

Question Mandatory : No

Correct Marks : 4 Wrong Marks : 1

ABCDEFHG ଗୋଟିଏ ସମାନ ବାହୁ ଯୁକ୍ତ ସମ ଅଷ୍ଟଭୁଜରେ ଯଦି  $\vec{AO} = 2\hat{i} + 3\hat{j} - 4\hat{k}$  ଅଟେ, ତେବେ

$\vec{AB} + \vec{AC} + \vec{AD} + \vec{AE} + \vec{AF} + \vec{AG} + \vec{AH}$  ର ସମଷ୍ଟି କେତେ ହେବ ?

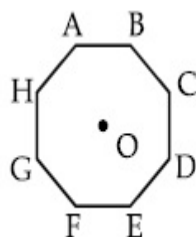

Options :

70819160077.

$$16\hat{i} + 24\hat{j} + 32\hat{k}$$

70819160078.  $-16\hat{i} - 24\hat{j} + 32\hat{k}$

70819160079.  $16\hat{i} - 24\hat{j} + 32\hat{k}$

70819160080.  $16\hat{i} + 24\hat{j} - 32\hat{k}$

**Question Number : 6 Question Id : 70819118309 Question Type : MCQ Option Shuffling : Yes Is**

**Question Mandatory : No**

**Correct Marks : 4 Wrong Marks : 1**

Two satellites A and B of masses 200 kg and 400 kg are revolving round the earth at height of 600 km and 1600 km respectively.

If  $T_A$  and  $T_B$  are the time periods of A and B respectively then the value of  $T_B - T_A$  :

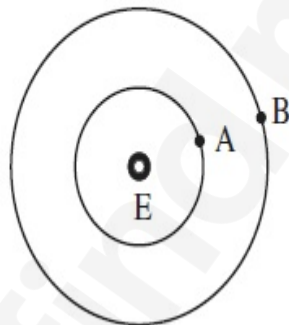

[ Given : radius of earth = 6400 km, mass of earth =  $6 \times 10^{24}$  kg ]

**Options :**

70819160081.  $1.33 \times 10^3$  s

70819160082.  $4.24 \times 10^3$  s

70819160083.  $4.24 \times 10^2$  s

70819160084.  $3.33 \times 10^2$  s

Question Number : 6 Question Id : 70819118309 Question Type : MCQ Option Shuffling : Yes Is Question Mandatory : No

Correct Marks : 4 Wrong Marks : 1

200 kg ଏବଂ 400 kg ବସ୍ତୁ ବିଶିଷ୍ଟ A ଓ B ଦୁଇଟି ଉପଗ୍ରହ ଯଥାକ୍ରମେ 600 km ଏବଂ 1600 km ଉଚ୍ଚତାରେ ପୃଥିବୀ ଚାରିପଟେ ପରିକ୍ରମଣ କରୁଛନ୍ତି । ଯଦି  $T_A$  ଏବଂ  $T_B$  ଯଥାକ୍ରମେ A ଓ B ର ଆବର୍ତ୍ତକାଳ, ତେବେ  $T_B - T_A$  ର ମୂଲ୍ୟ ଅଟେ :  
 [ ବୃତ୍ତ: ପୃଥିବୀର ବ୍ୟାସାର୍ଦ୍ଧ = 6400 km ପୃଥିବୀର ବସ୍ତୁତ୍ଵ =  $6 \times 10^{24}$  kg ]

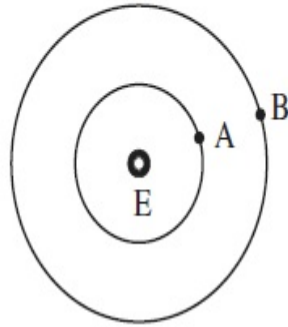

Options :

70819160081.  $1.33 \times 10^3$  s

70819160082.  $4.24 \times 10^3$  s

70819160083.  $4.24 \times 10^2$  s

70819160084.  $3.33 \times 10^2$  s

Question Number : 7 Question Id : 70819118310 Question Type : MCQ Option Shuffling : Yes Is Question Mandatory : No

Correct Marks : 4 Wrong Marks : 1

A 5 V battery is connected across the points X and Y. Assume  $D_1$  and  $D_2$  to be ideal diodes. Find the current supplied by the battery if the +ve terminal of the battery is connected to point X.

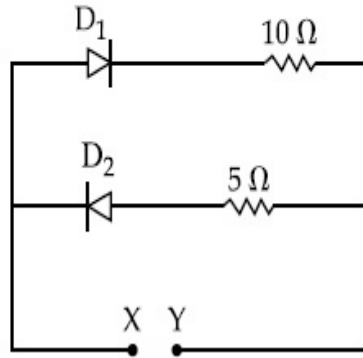

Options :

70819160085.  $\sim 0.5 \text{ A}$

70819160086.  $\sim 0.43 \text{ A}$

70819160087.  $\sim 0.86 \text{ A}$

70819160088.  $\sim 1.5 \text{ A}$

Question Number : 7 Question Id : 70819118310 Question Type : MCQ Option Shuffling : Yes Is

Question Mandatory : No

Correct Marks : 4 Wrong Marks : 1

X ଏବଂ Y ବିନ୍ଦୁ ମଧ୍ୟରେ ଗୋଟିଏ 5 V ବ୍ୟାଟେରୀକୁ ସଂଯୋଗ କରାଯାଇଛି । ଧର  $D_1$  ଏବଂ  $D_2$  ଦୁଇଟି ସାଧାରଣ ସିଲିକନ୍ ଡାଇଓଡ୍ । ଯଦି ବ୍ୟାଟେରୀର +ve ମୁଣ୍ଡଟି X କୁ ସଂଯୋଗ ହୋଇଥାଏ, ତେବେ ବ୍ୟାଟେରୀ ଯୋଗାଇଥିବା ବିଦ୍ୟୁତ୍ ସ୍ରୋତ ନିର୍ଣ୍ଣୟ କର ।

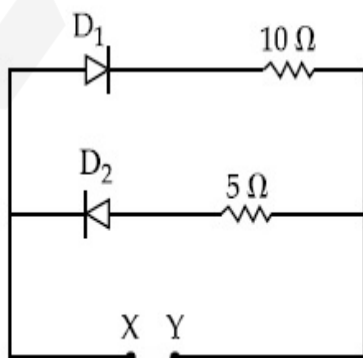

Options :

70819160085. ~0.5 A

70819160086. ~0.43 A

70819160087. ~0.86 A

70819160088. ~1.5 A

**Question Number : 8 Question Id : 70819118311 Question Type : MCQ Option Shuffling : Yes Is**

**Question Mandatory : No**

**Correct Marks : 4 Wrong Marks : 1**

Given below are two statements :

Statement I : A speech signal of 2 kHz is used to modulate a carrier signal of 1 MHz. The bandwidth requirement for the signal is 4 kHz.

Statement II : The side band frequencies are 1002 kHz and 998 kHz.

In the light of the above statements, choose the correct answer from the options given below :

**Options :**

70819160089. Both Statement I and Statement II are true

70819160090. Both Statement I and Statement II are false

70819160091. Statement I is true but Statement II is false

70819160092. Statement I is false but Statement II is true

**Question Number : 8 Question Id : 70819118311 Question Type : MCQ Option Shuffling : Yes Is**

**Question Mandatory : No**

**Correct Marks : 4 Wrong Marks : 1**

ନିମ୍ନରେ ଦୁଇଟି ଉକ୍ତି ଦିଆଯାଇଛି :

ଉକ୍ତି I : 1 MHz ବିଶିଷ୍ଟ ଗୋଟିଏ ବାହକ ସଂକେତକୁ ମଡୁଲନ୍ କରିବା ପାଇଁ ଏକ 2 kHz ବିଶିଷ୍ଟ ଶବ୍ଦ ସଂକେତ (ସିଗ୍ନାଲ୍) ବ୍ୟବହାର କରାଯାଏ । ସଂକେତଟି ପାଇଁ ଆବଶ୍ୟକ ପଡୁଥିବା ବ୍ୟାଣ୍ଡ ଚଉଡ଼ା 4 kHz ଅଟେ ।

ଉକ୍ତି II : ପାର୍ଶ୍ୱ ବ୍ୟାଣ୍ଡ ଆବୃତ୍ତି ଗୁଡ଼ିକ ହେଲା 1002 kHz ଏବଂ 998 kHz ।

ଉପରୋକ୍ତ ଉକ୍ତିଗୁଡ଼ିକ ଅନୁସାରେ, ନିମ୍ନରେ ଦତ୍ତ ବିକଳ୍ପ ଗୁଡ଼ିକ ମଧ୍ୟରୁ ଠିକ୍ ଉତ୍ତରଟି ଚୟନ କର :

**Options :**

70819160089. ଉଭୟ ଉକ୍ତି I ଏବଂ ଉକ୍ତି II ସତ୍ୟ ଅଟେ ।

70819160090. ଉଭୟ ଉକ୍ତି I ଏବଂ ଉକ୍ତି II ମିଥ୍ୟା ଅଟେ ।

70819160091. ଉକ୍ତି I ଠିକ୍ ଅଟେ କିନ୍ତୁ ଉକ୍ତି II ଠିକ୍ ମିଥ୍ୟା ଅଟେ ।

70819160092. ଉକ୍ତି I ଠିକ୍ କିନ୍ତୁ ଉକ୍ତି II ଠିକ୍ ସତ୍ୟ ଅଟେ ।

**Question Number : 9 Question Id : 70819118312 Question Type : MCQ Option Shuffling : Yes Is**

**Question Mandatory : No**

**Correct Marks : 4 Wrong Marks : 1**

Given below are two statements : one is labelled as Assertion A and the other is labelled as Reason R.

Assertion A : When a rod lying freely is heated, no thermal stress is developed in it.

Reason R : On heating, the length of the rod increases.

In the light of the above statements, choose the correct answer from the options given below :

**Options :**

70819160093. Both A and R are true and R is the correct explanation of A

70819160094. Both A and R are true but R is NOT the correct explanation of A

70819160095. A is true but R is false

70819160096. A is false but R is true

Question Number : 9 Question Id : 70819118312 Question Type : MCQ Option Shuffling : Yes Is Question Mandatory : No

Correct Marks : 4 Wrong Marks : 1

ନିମ୍ନରେ ଦୁଇଟି ଉକ୍ତି ଦିଆଯାଇଛି । ଗୋଟିଏ ଘୋଷଣା **A** ଓ ଅନ୍ୟଟି କାରଣ **R** ଆକାରରେ ଚିହ୍ନିତ ହୋଇଛନ୍ତି ।

ଘୋଷଣା **A** : ଯେତେବେଳେ ମୁକ୍ତ ଭାବରେ ଥିବା ଏକ ଦଣ୍ଡଟିକୁ ଗରମ କରାଯାଏ, କୌଣସି ତାପୀୟ ଷ୍ଟ୍ରେସ୍ ଏଥିରେ ସୃଷ୍ଟି ହୁଏ ନାହିଁ ।

କାରଣ **R** : ଗରମ ଯୋଗୁଁ, ରତ୍ନର ଦୈର୍ଘ୍ୟ ବୃଦ୍ଧି ପାଇଥାଏ ।

ଉପରୋକ୍ତ ଉକ୍ତି ଅନୁସାରେ, ନିମ୍ନରେ ଦତ୍ତ ବିକଳ୍ପ ଗୁଡ଼ିକରୁ ସର୍ବୋତ୍ତମ ଉତ୍ତରଟି ଚୟନ କର :

Options :

70819160093. ଉଭୟ **A** ଏବଂ **R** ଠିକ୍ ଏବଂ **R** ହେଉଛି **A**ର ଠିକ୍ ବ୍ୟାଖ୍ୟା ।

70819160094. ଉଭୟ **A** ଏବଂ **R** ଠିକ୍ କିନ୍ତୁ **R**, **A**ର ଠିକ୍ ବ୍ୟାଖ୍ୟା ନୁହେଁ ।

70819160095. **A** ସତ୍ୟ ଅଟେ କିନ୍ତୁ **R** ମିଥ୍ୟା ଅଟେ ।

70819160096. **A** ମିଥ୍ୟା ଅଟେ କିନ୍ତୁ **R** ସତ୍ୟ ଅଟେ ।

Question Number : 10 Question Id : 70819118313 Question Type : MCQ Option Shuffling : Yes Is Question Mandatory : No

Correct Marks : 4 Wrong Marks : 1

The current ( $i$ ) at time  $t=0$  and  $t=\infty$  respectively for the given circuit is :

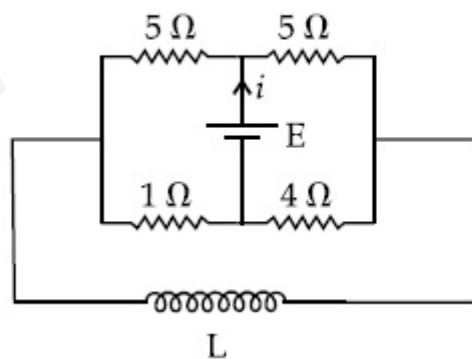

Options :

70819160097.  $\frac{18E}{55}$ ,  $\frac{5E}{18}$

70819160098.  $\frac{5E}{18}, \frac{18E}{55}$

70819160099.  $\frac{10E}{33}, \frac{5E}{18}$

70819160100.  $\frac{5E}{18}, \frac{10E}{33}$

**Question Number : 10 Question Id : 70819118313 Question Type : MCQ Option Shuffling : Yes Is Question Mandatory : No**

**Correct Marks : 4 Wrong Marks : 1**

ଦିଆଯାଇଥିବା ବିଦ୍ୟୁତ୍ ପରିପଥ ପାଇଁ  $t=0$  ଏବଂ  $t=\infty$  ସମୟରେ ବିଦ୍ୟୁତ୍ ସ୍ରୋତ ( $i$ ) ବାହାର କର ।

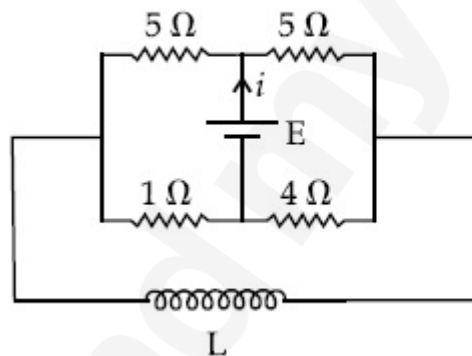

**Options :**

70819160097.  $\frac{18E}{55}, \frac{5E}{18}$

70819160098.  $\frac{5E}{18}, \frac{18E}{55}$

70819160099.  $\frac{10E}{33}, \frac{5E}{18}$

70819160100.  $\frac{5E}{18}, \frac{10E}{33}$

**Question Number : 11 Question Id : 70819118314 Question Type : MCQ Option Shuffling : Yes**  
**Is Question Mandatory : No**

**Correct Marks : 4 Wrong Marks : 1**

The pitch of the screw gauge is 1 mm and there are 100 divisions on the circular scale. When nothing is put in between the jaws, the zero of the circular scale lies 8 divisions below the reference line. When a wire is placed between the jaws, the first linear scale division is clearly visible while 72<sup>nd</sup> division on circular scale coincides with the reference line. The radius of the wire is :

**Options :**

70819160101. 1.64 mm

70819160102. 0.90 mm

70819160103. 0.82 mm

70819160104. 1.80 mm

**Question Number : 11 Question Id : 70819118314 Question Type : MCQ Option Shuffling : Yes**  
**Is Question Mandatory : No**

**Correct Marks : 4 Wrong Marks : 1**

ଗୋଟିଏ ସ୍କ୍ରୋ ଗଜର ପିଚ୍ 1 mm ଅଟେ ଏବଂ ଏହାର ବୃତ୍ତାକାର ସ୍କେଲରେ 100 ଭାଗ ରହିଛି । ଯେତେବେଳେ ଦାନ୍ତି ଦୁଇଟି ମଧ୍ୟରେ କିଛି ରଖାଯାଇ ନଥାଏ, ବୃତ୍ତାକାର ସ୍କେଲର ଶୂନ୍ୟ (ଜିରୋ) ନିର୍ଦ୍ଦେଶ ରେଖା (ରେଫରେନ୍ସ ଲାଇନ୍) ରୁ 8 ଭାଗ ତଳକୁ ରହିଥାଏ । ଯେତେବେଳେ ଗୋଟିଏ ତାର ଦାନ୍ତି ଦୁଇଟି ମଧ୍ୟରେ ରଖାଯାଏ, ଗୋଟିଏ ସଲଖ ସ୍କେଲର ପ୍ରଥମ ଭାଗଟି ପରିଷ୍କାର ଦେଖାଯାଏ । ଯେତେବେଳେ ବୃତ୍ତାକାର ସ୍କେଲର 72 ଚମ ଭାଗଟି ନିର୍ଦ୍ଦେଶ ରେଖା ସହ ମିଳିତ ହୋଇ ରହିଥାଏ । ତାରଟିର ବ୍ୟାସାର୍ଦ୍ଧ ହେଉଛି \_\_\_\_\_ ।

**Options :**

70819160101. 1.64 mm

70819160102. 0.90 mm

70819160103. 0.82 mm

70819160104. 1.80 mm

**Question Number : 12 Question Id : 70819118315 Question Type : MCQ Option Shuffling : Yes  
Is Question Mandatory : No**

**Correct Marks : 4 Wrong Marks : 1**

An  $\alpha$  particle and a proton are accelerated from rest by a potential difference of 200 V. After

this, their de Broglie wavelengths are  $\lambda_\alpha$  and  $\lambda_p$  respectively. The ratio  $\frac{\lambda_p}{\lambda_\alpha}$  is :

**Options :**

70819160105. 2.8

70819160106. 8

70819160107. 7.8

70819160108. 3.8

**Question Number : 12 Question Id : 70819118315 Question Type : MCQ Option Shuffling : Yes  
Is Question Mandatory : No**

**Correct Marks : 4 Wrong Marks : 1**

ଏକ 200 V ବିଶିଷ୍ଟ ବିଭବ ପାର୍ଥକ୍ୟ ଦ୍ୱାରା ଗୋଟିଏ  $\alpha$ -କଣିକା ଓ ଗୋଟିଏ ପ୍ରୋଟନ୍ ସ୍ଥିର ଅବସ୍ଥାରୁ ତ୍ୱରିତ ହେଲେ ।

ଏହାପରେ, ସେମାନଙ୍କର ତି- ବ୍ରୋଗଲି ତରଙ୍ଗ ଦୈର୍ଘ୍ୟ ଗୁଡ଼ିକ ଯଥାକ୍ରମେ  $\lambda_\alpha$  ଏବଂ  $\lambda_p$  ଅଟେ । ଅନୁପାତ  $\frac{\lambda_p}{\lambda_\alpha}$  ର ନିକଟତମ

ମୂଲ୍ୟ ହେଉଛି \_\_\_\_\_ ।

**Options :**

70819160105. 2.8

70819160106. 8

70819160107. 7.8

70819160108. 3.8

**Question Number : 13 Question Id : 70819118316 Question Type : MCQ Option Shuffling : Yes**

**Is Question Mandatory : No**

**Correct Marks : 4 Wrong Marks : 1**

Two coherent light sources having intensity in the ratio  $2x$  produce an interference pattern.

The ratio  $\frac{I_{\max} - I_{\min}}{I_{\max} + I_{\min}}$  will be :

**Options :**

70819160109.  $\frac{\sqrt{2x}}{2x+1}$

70819160110.  $\frac{2\sqrt{2x}}{2x+1}$

70819160111.  $\frac{\sqrt{2x}}{x+1}$

70819160112.  $\frac{2\sqrt{2x}}{x+1}$

**Question Number : 13 Question Id : 70819118316 Question Type : MCQ Option Shuffling : Yes**

**Is Question Mandatory : No**

**Correct Marks : 4 Wrong Marks : 1**

$\frac{I_{\max} - I_{\min}}{I_{\max} + I_{\min}}$  ଅନୁପାତ ହେବ \_\_\_\_\_ ।

**Options :**

70819160109.  $\frac{\sqrt{2x}}{2x+1}$

70819160110.  $\frac{2\sqrt{2x}}{2x+1}$

70819160111.  $\frac{\sqrt{2x}}{x+1}$

70819160112.  $\frac{2\sqrt{2x}}{x+1}$

**Question Number : 14 Question Id : 70819118317 Question Type : MCQ Option Shuffling : Yes**

**Is Question Mandatory : No**

**Correct Marks : 4 Wrong Marks : 1**

An engine of a train, moving with uniform acceleration, passes the signal-post with velocity  $u$  and the last compartment with velocity  $v$  . The velocity with which middle point of the train passes the signal post is :

**Options :**

70819160113.  $\frac{u+v}{2}$

70819160114.  $\frac{v-u}{2}$

70819160115.  $\sqrt{\frac{v^2 + u^2}{2}}$

70819160116.  $\sqrt{\frac{v^2 - u^2}{2}}$

**Question Number : 14 Question Id : 70819118317 Question Type : MCQ Option Shuffling : Yes**

**Is Question Mandatory : No**

**Correct Marks : 4 Wrong Marks : 1**

ସମାନ ଭୂରଣରେ ଗତି କରୁଥିବା ଗୋଟିଏ ଟ୍ରେନ୍‌ର ଇଞ୍ଜିନ୍ ଗୋଟିଏ ସିଗ୍ନାଲ୍ - ପୋଷ୍ଟକୁ  $u$  ପରିବେଗରେ ଏବଂ ଶେଷ ବଗି(କମ୍ପାର୍ଟମେଣ୍ଟ)  $v$  ପରିବେଗରେ ଅତିକ୍ରମ କରିଥାଏ । ଟ୍ରେନ୍‌ଟିର ମଧ୍ୟବର୍ତ୍ତୀ ବିନ୍ଦୁ ସିଗ୍ନାଲ୍ ପୋଷ୍ଟକୁ ଅତିକ୍ରମ କରୁଥିବା ପରିବେଗ ହେଉଛି \_\_\_\_\_ ।

**Options :**

70819160113.  $\frac{u+v}{2}$

70819160114.  $\frac{v-u}{2}$

70819160115.  $\sqrt{\frac{v^2 + u^2}{2}}$

70819160116.  $\sqrt{\frac{v^2 - u^2}{2}}$

**Question Number : 15 Question Id : 70819118318 Question Type : MCQ Option Shuffling : Yes**

**Is Question Mandatory : No**

**Correct Marks : 4 Wrong Marks : 1**

A proton, a deuteron and an  $\alpha$  particle are moving with same momentum in a uniform magnetic field. The ratio of magnetic forces acting on them is \_\_\_\_\_ and their speed is \_\_\_\_\_, in the ratio.

**Options :**

70819160117. 4 : 2 : 1 and 2 : 1 : 1

70819160118. 2 : 1 : 1 and 4 : 2 : 1

70819160119. 1 : 2 : 4 and 1 : 1 : 2

70819160120. 1 : 2 : 4 and 2 : 1 : 1

**Question Number : 15 Question Id : 70819118318 Question Type : MCQ Option Shuffling : Yes**

**Is Question Mandatory : No**

**Correct Marks : 4 Wrong Marks : 1**

ଏକା ସଂବେଗ ସହ ଗୋଟିଏ ପ୍ରୋଟନ୍, ଗୋଟିଏ ଡିୟୁଟେରନ୍ ଏବଂ ଗୋଟିଏ  $\alpha$  - କଣିକା ଏକ ସମ ତୁମ୍ଭକାୟ କ୍ଷେତ୍ରରେ ଗତି କରୁଛନ୍ତି । ସେମାନଙ୍କ ଉପରେ କାର୍ଯ୍ୟ କରୁଥିବା ତୁମ୍ଭକାୟ ବଳ ଓ ସେମାନଙ୍କର ବେଗର ଅନୁପାତ, ଦିଆଯାଇଥିବା କ୍ରମରେ \_\_\_\_\_ ଏବଂ \_\_\_\_\_ ହେବ ।

**Options :**

70819160117. 4 : 2 : 1 ଏବଂ 2 : 1 : 1

70819160118. 2 : 1 : 1 ଏବଂ 4 : 2 : 1

70819160119. 1 : 2 : 4 ଏବଂ 1 : 1 : 2

70819160120. 1 : 2 : 4 ଏବଂ 2 : 1 : 1

**Question Number : 16 Question Id : 70819118319 Question Type : MCQ Option Shuffling : Yes**

**Is Question Mandatory : No**

**Correct Marks : 4 Wrong Marks : 1**

Magnetic fields at two points on the axis of a circular coil at a distance of 0.05 m and 0.2 m from the centre are in the ratio 8 : 1. The radius of coil is \_\_\_\_\_.

**Options :**

70819160121. 0.1 m

70819160122. 0.15 m

70819160123. 0.2 m

70819160124. 1.0 m

**Question Number : 16 Question Id : 70819118319 Question Type : MCQ Option Shuffling : Yes**

**Is Question Mandatory : No**

**Correct Marks : 4 Wrong Marks : 1**

ଗୋଟିଏ ବୃତ୍ତାକାର କୁଣ୍ଡଳୀର ଅକ୍ଷ ଉପରେ ଏହାର କେନ୍ଦ୍ର ଠାରୁ 0.05 m ଏବଂ 0.2 m ଦୂରତାରେ ଥିବା ଦୁଇଟି ବିନ୍ଦୁରେ ସ୍ୱଳ୍ପ ବୃତ୍ତାକାର କ୍ଷେତ୍ରର ଅନୁପାତ 8 : 1 ଅଟେ । କୁଣ୍ଡଳୀଟିର ବ୍ୟାସାର୍ଦ୍ଧ ହେଉଛି \_\_\_\_\_ ।

**Options :**

70819160121. 0.1 m

70819160122. 0.15 m

70819160123. 0.2 m

70819160124. 1.0 m

**Question Number : 17 Question Id : 70819118320 Question Type : MCQ Option Shuffling : Yes**

**Is Question Mandatory : No**

**Correct Marks : 4 Wrong Marks : 1**

The angular frequency of alternating current in a L-C-R circuit is 100 rad/s. The components connected are shown in the figure. Find the value of inductance of the coil and capacity of condenser.

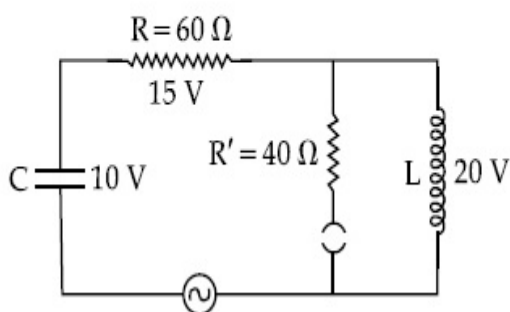

Options :

70819160125. 1.33 H and 250  $\mu$ F

70819160126. 1.33 H and 150  $\mu$ F

70819160127. 0.8 H and 150  $\mu$ F

70819160128. 0.8 H and 250  $\mu$ F

Question Number : 17 Question Id : 70819118320 Question Type : MCQ Option Shuffling : Yes

Is Question Mandatory : No

Correct Marks : 4 Wrong Marks : 1

ଗୋଟିଏ L-C-R ପରିପଥରେ ପ୍ରତ୍ୟାବର୍ତ୍ତୀ ବିଦ୍ୟୁତ୍ ସ୍ରୋତର କୌଣସି ଆବୃତ୍ତି 100 rad/s. ଅଟେ । ଚିତ୍ରରେ ଦର୍ଶାଯାଇଥିବା ଅନୁସାରେ ଉପାଦାନ ଗୁଡ଼ିକୁ ସଂଯୋଗ କରାଯାଇଛି । କଏଲର ପ୍ରଶୋଦକତା ଏବଂ ଧାରତ୍ତ୍ୱର ଧାରିତ୍ରା ବାହାର କର ।

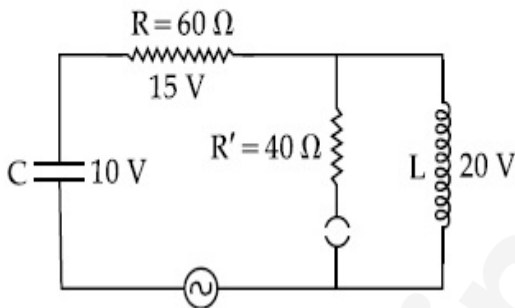

Options :

70819160125. 1.33 H ଏବଂ 250  $\mu$ F

70819160126. 1.33 H ଏବଂ 150  $\mu$ F

70819160127. 0.8 H ଏବଂ 150  $\mu$ F

70819160128. 0.8 H ଏବଂ 250  $\mu$ F

Question Number : 18 Question Id : 70819118321 Question Type : MCQ Option Shuffling : Yes

Is Question Mandatory : No

Correct Marks : 4 Wrong Marks : 1

A diatomic gas, having  $C_p = \frac{7}{2}R$  and  $C_v = \frac{5}{2}R$ , is heated at constant pressure. The ratio  $dU : dQ : dW$ :

Options :

70819160129. 5 : 7 : 2

70819160130. 3 : 7 : 2

70819160131. 3 : 5 : 2

70819160132. 5 : 7 : 3

Question Number : 18 Question Id : 70819118321 Question Type : MCQ Option Shuffling : Yes

Is Question Mandatory : No

Correct Marks : 4 Wrong Marks : 1

$C_p = \frac{7}{2}R$  ଏବଂ  $C_v = \frac{5}{2}R$  ଥିବା ଗୋଟିଏ ଦ୍ୱି-ପରମାଣୁକ ଗ୍ୟାସକୁ ସ୍ଥିର ଚାପରେ ଗରମ କରାଗଲା ।  $dU : dQ : dW$  ର ଅନୁପାତ ହେଉଛି :

Options :

70819160129. 5 : 7 : 2

70819160130. 3 : 7 : 2

70819160131. 3 : 5 : 2

70819160132. 5 : 7 : 3

Question Number : 19 Question Id : 70819118322 Question Type : MCQ Option Shuffling : Yes

Is Question Mandatory : No

Correct Marks : 4 Wrong Marks : 1

Two radioactive substances X and Y originally have  $N_1$  and  $N_2$  nuclei respectively. Half life of X is half of the half life of Y. After three half lives of Y, number of nuclei of both are equal.

The ratio  $\frac{N_1}{N_2}$  will be equal to :

Options :

70819160133.  $\frac{3}{1}$

70819160134.  $\frac{1}{3}$

70819160135.  $\frac{8}{1}$

70819160136.  $\frac{1}{8}$

Question Number : 19 Question Id : 70819118322 Question Type : MCQ Option Shuffling : Yes

Is Question Mandatory : No

Correct Marks : 4 Wrong Marks : 1

ଆରମ୍ଭରୁ ଦୁଇଟି ତେଜସ୍ବିୟ ପଦାର୍ଥ X ଏବଂ Y ର ନ୍ୟୁକ୍ଲୀୟ ସଂଖ୍ୟା ଯଥାକ୍ରମେ  $N_1$  ଓ  $N_2$  ଅଛି । X ର ଅର୍ଦ୍ଧ ଆୟୁ Y ର

ଅର୍ଦ୍ଧ ଆୟୁର ଅଧା ଅଟେ । Y ର ତିନି ଅର୍ଦ୍ଧ ଆୟୁ ସମୟ ପରେ, ଦୁଇଟି ଯାକର ନ୍ୟୁକ୍ଲୀୟ ସଂଖ୍ୟା ସମାନ ହେଉଛି ।  $\frac{N_1}{N_2}$  ର

ଅନୁପାତ ସମାନ ହେବ \_\_\_\_\_ ।

Options :

70819160133.  $\frac{3}{1}$

70819160134.  $\frac{1}{3}$

70819160135.  $\frac{8}{1}$

70819160136.  $\frac{1}{8}$

**Question Number : 20 Question Id : 70819118323 Question Type : MCQ Option Shuffling : Yes**

**Is Question Mandatory : No**

**Correct Marks : 4 Wrong Marks : 1**

A solid sphere of radius  $R$  gravitationally attracts a particle placed at  $3R$  from its centre with a force  $F_1$ . Now a spherical cavity of radius  $\left(\frac{R}{2}\right)$  is made in the sphere (as shown in figure) and the force becomes  $F_2$ . The value of  $F_1 : F_2$  is :

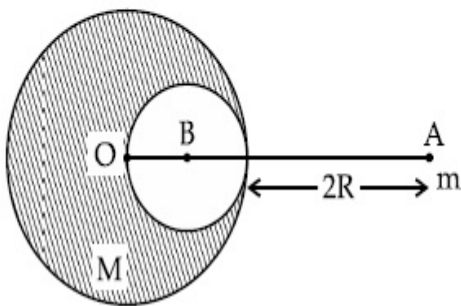

**Options :**

70819160137. 41 : 50

70819160138. 50 : 41

70819160139. 36 : 25

70819160140. 25 : 36

**Question Number : 20 Question Id : 70819118323 Question Type : MCQ Option Shuffling : Yes**

**Is Question Mandatory : No**

Correct Marks : 4 Wrong Marks : 1

R ବ୍ୟାସାର୍ଦ୍ଧ ବିଶିଷ୍ଟ ଏକ ନିଦା ଗୋଲକ ଏହାର କେନ୍ଦ୍ର O ରୁ  $3R$  ଦୂରତାରେ ଥିବା ଏକ କଣିକାକୁ  $F_1$  ବଳରେ ମାଧ୍ୟାକର୍ଷଣୀୟ ଆକର୍ଷଣ କରୁଅଛି । ବର୍ତ୍ତମାନ ଗୋଲକଟି ମଧ୍ୟରେ  $\left(\frac{R}{2}\right)$  ବ୍ୟାସାର୍ଦ୍ଧ ବିଶିଷ୍ଟ ଏକ ଗୋଲାକାର ଗହ୍ୱର (କ୍ୟାଭିଟି) ତିଆରି କରାଗଲା (ଚିତ୍ରରେ ଦର୍ଶାଯାଇଥିବା ଅନୁସାରେ) ଏବଂ ବଳଟି  $F_2$  ହୋଇଗଲା ।  $F_1/F_2$  ର ମୂଲ୍ୟ ହେଉଛି \_\_\_\_\_ ।

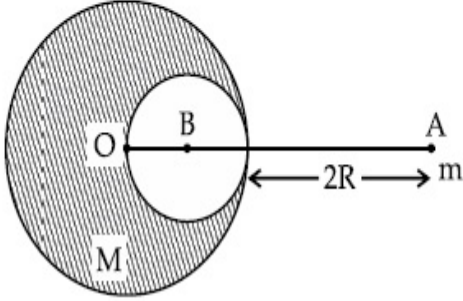

Options :

70819160137. 41 : 50

70819160138. 50 : 41

70819160139. 36 : 25

70819160140. 25 : 36

## Physics Section B

Section Id :	708191761
Section Number :	2
Section type :	Online
Mandatory or Optional :	Mandatory
Number of Questions :	10
Number of Questions to be attempted :	5
Section Marks :	20
Mark As Answered Required? :	Yes

Sub-Section Number :

1

Sub-Section Id :

7081911041

Question Shuffling Allowed :

Yes

Question Number : 21 Question Id : 70819118324 Question Type : SA

Correct Marks : 4 Wrong Marks : 0

A monoatomic gas of mass  $4.0 \text{ u}$  is kept in an insulated container. Container is moving with velocity  $30 \text{ m/s}$ . If container is suddenly stopped then change in temperature of the gas

( $R =$  gas constant) is  $\frac{x}{3R}$ . Value of  $x$  is \_\_\_\_\_.

Response Type : Numeric

Evaluation Required For SA : Yes

Show Word Count : Yes

Answers Type : Range

Text Areas : PlainText

Possible Answers :

5 to 5.001

Question Number : 21 Question Id : 70819118324 Question Type : SA

Correct Marks : 4 Wrong Marks : 0

ଏକ ତାପରୋଧୀ ଧାରକରେ  $4.0 \text{ u}$  ବସ୍ତୁତ୍ଵର ଗୋଟିଏ ଏକ ପରମାଣବୀୟ ଗ୍ୟାସ୍ ରଖାଯାଇଛି । ଧାରକଟି  $30 \text{ m/s}$  ପରିବେଗରେ ଗତି କରୁଅଛି । ଯଦି ଧାରକଟିର ଗତି ହଠାତ୍ ବନ୍ଦ ହୋଇଯାଏ ତେବେ ଗ୍ୟାସ୍ ( $R =$  ଗ୍ୟାସ୍ ସ୍ଥିରାଙ୍କ)ର

ତାପମାତ୍ରାରେ ପରିବର୍ତ୍ତନ  $\frac{x}{3R}$  ହେବ ।  $x$  ର ମୂଲ୍ୟ ଅଟେ \_\_\_\_\_ ।

Response Type : Numeric

Evaluation Required For SA : Yes

Show Word Count : Yes

Answers Type : Range

Text Areas : PlainText

Possible Answers :

5 to 5.001

Question Number : 22 Question Id : 70819118325 Question Type : SA

Correct Marks : 4 Wrong Marks : 0

512 identical drops of mercury are charged to a potential of 2 V each. The drops are joined to form a single drop. The potential of this drop is \_\_\_\_\_ V.

Response Type : Numeric

Evaluation Required For SA : Yes

Show Word Count : Yes

Answers Type : Range

Text Areas : PlainText

Possible Answers :

5 to 5.001

Question Number : 22 Question Id : 70819118325 Question Type : SA

Correct Marks : 4 Wrong Marks : 0

ଏକା ଭଳି 512 ଟି ପାରଦ ଗୋପାକୁ ପ୍ରତ୍ୟେକ 2 V ବିଭବକୁ ଚାର୍ଜିତ କରାଗଲା । ଗୋପାଗୁଡ଼ିକୁ ମିଶାଇ ଗୋଟିଏ ଗୋପା କରାଗଲା । ଏହି ଗୋପାଟିର ବିଭବ \_\_\_\_\_ ଭୋଲ୍ଟ ଅଟେ ।

Response Type : Numeric

Evaluation Required For SA : Yes

Show Word Count : Yes

Answers Type : Range

Text Areas : PlainText

Possible Answers :

5 to 5.001

Question Number : 23 Question Id : 70819118326 Question Type : SA

Correct Marks : 4 Wrong Marks : 0

A coil of inductance 2 H having negligible resistance is connected to a source of supply whose voltage is given by  $V = 3t$  volt. (where  $t$  is in second). If the voltage is applied when  $t = 0$ , then the energy stored in the coil after 4 s is \_\_\_\_\_ J.

Response Type : Numeric

Evaluation Required For SA : Yes

Show Word Count : Yes

Answers Type : Range

Text Areas : PlainText

Possible Answers :

5 to 5.001

Question Number : 23 Question Id : 70819118326 Question Type : SA

Correct Marks : 4 Wrong Marks : 0

ନଗଣ୍ୟ ପ୍ରତିରୋଧ ଥାଇ ଏକ  $2\text{ H}$  ପ୍ରଶୋଦକତା ଥିବା ତାର କୁଣ୍ଡଳକୁ ଗୋଟିଏ ଯୋଗାଣକାରୀ ଉତ୍ତ ସହ ସଂଯୋଗ କରାଯାଇଛି ଯାହାର ଭୋଲଟେଜ୍  $V=3t$  ଭୋଲଟ୍ (ଯେଉଁଠି 't' ସେକେଣ୍ଡରେ ଅଛି) ଦ୍ୱାରା ଦର୍ଶାଯାଇଛି । ଯଦି  $t=0$  ଥିବା ସମୟରେ ଭୋଲଟେଜ୍‌ଟି ପ୍ରୟୋଗ କରାଯାଏ, ତେବେ 4 ସେକେଣ୍ଡ ପରେ ତାର କୁଣ୍ଡଳରେ ଗଠିତ ହେଉଥିବା ଶକ୍ତି ହେଉଛି \_\_\_\_\_ J ।

Response Type : Numeric

Evaluation Required For SA : Yes

Show Word Count : Yes

Answers Type : Range

Text Areas : PlainText

Possible Answers :

5 to 5.001

Question Number : 24 Question Id : 70819118327 Question Type : SA

Correct Marks : 4 Wrong Marks : 0

A small bob tied at one end of a thin string of length 1 m is describing a vertical circle so that the maximum and minimum tension in the string are in the ratio 5 : 1. The velocity of the bob at the highest position is \_\_\_\_\_ m/s. (Take  $g=10\text{ m/s}^2$ )

Response Type : Numeric

Evaluation Required For SA : Yes

Show Word Count : Yes

Answers Type : Range

Text Areas : PlainText

Possible Answers :

**Question Number : 24 Question Id : 70819118327 Question Type : SA**

**Correct Marks : 4 Wrong Marks : 0**

1 m ଦୈର୍ଘ୍ୟ ବିଶିଷ୍ଟ ଏକ ପତଳା ସୂତାର ଗୋଟିଏ ମୁଣ୍ଡରେ ବନ୍ଧା ହୋଇଥିବା ଗୋଟିଏ କ୍ଷୁଦ୍ର ବସ୍ ଏକ ଭୂଲମ୍ବ ବୃତ୍ତରେ ଗତି କରୁଛି ଯେମିତିକି ଦଉଡ଼ିତିରେ ହେଉଥିବା ସର୍ବୋଚ୍ଚ ଏବଂ ସର୍ବନିମ୍ନ ଚେନ୍ଦ୍ରଣର ଅନୁପାତ 5 : 1 ଅଟେ । ଉଚ୍ଚତମ ସ୍ଥାନରେ ବସ୍‌ଟିର ପରିବେଗ ହେଉଛି \_\_\_\_\_ m/s । (ଧର  $g=10 \text{ m/s}^2$ )

**Response Type : Numeric**

**Evaluation Required For SA : Yes**

**Show Word Count : Yes**

**Answers Type : Range**

**Text Areas : PlainText**

**Possible Answers :**

5 to 5.001

**Question Number : 25 Question Id : 70819118328 Question Type : SA**

**Correct Marks : 4 Wrong Marks : 0**

The potential energy (U) of a diatomic molecule is a function dependent on r (interatomic distance) as

$$U = \frac{\alpha}{r^{10}} - \frac{\beta}{r^5} - 3$$

where,  $\alpha$  and  $\beta$  are positive constants. The equilibrium distance between two atoms will be

$$\left( \frac{2\alpha}{\beta} \right)^{\frac{a}{b}}, \text{ where } a = \underline{\hspace{2cm}} .$$

**Response Type : Numeric**

**Evaluation Required For SA : Yes**

**Show Word Count : Yes**

**Answers Type : Range**

**Text Areas : PlainText**

**Possible Answers :**

5 to 5.001

Question Number : 25 Question Id : 70819118328 Question Type : SA

Correct Marks : 4 Wrong Marks : 0

ଗୋଟିଏ ଦ୍ୱି-ପରମାଣୁ ଅଣୁର ଛିଡିକ ଶକ୍ତି (U),  $U = \frac{\alpha}{r^{10}} - \frac{\beta}{r^5} - 3$  ଆକାରରେ r (ଆନ୍ତଃପରମାଣବିକ ଦୂରତା) ଉପରେ

ନିର୍ଭର କରୁଥିବା ଏକ ଫଳନ, ଯେଉଁଠାରେ  $\alpha$  ଏବଂ  $\beta$  ଦୁଇଟି ଧନାତ୍ମକ ଧ୍ରୁବଙ୍କ ।

ସନ୍ତୁଳନ ଅବସ୍ଥାରେ ପରମାଣୁ ଦୁଇଟି ମଧ୍ୟରେ ଦୂରତା ହେବ  $\left(\frac{2\alpha}{\beta}\right)^{\frac{a}{b}}$  ଯେତେବେଳେ  $a = \underline{\hspace{2cm}}$  ।

Response Type : Numeric

Evaluation Required For SA : Yes

Show Word Count : Yes

Answers Type : Range

Text Areas : PlainText

Possible Answers :

5 to 5.001

Question Number : 26 Question Id : 70819118329 Question Type : SA

Correct Marks : 4 Wrong Marks : 0

The electric field in a region is given by  $\vec{E} = \left(\frac{3}{5}E_0 \hat{i} + \frac{4}{5}E_0 \hat{j}\right) \frac{N}{C}$ . The ratio of flux of reported

field through the rectangular surface of area  $0.2 \text{ m}^2$  (parallel to  $y-z$  plane) to that of the surface of area  $0.3 \text{ m}^2$  (parallel to  $x-z$  plane) is  $a : b$ , where  $a = \underline{\hspace{2cm}}$  .

[Here  $\hat{i}$ ,  $\hat{j}$  and  $\hat{k}$  are unit vectors along  $x$ ,  $y$  and  $z$ -axes respectively]

Response Type : Numeric

Evaluation Required For SA : Yes

Show Word Count : Yes

Answers Type : Range

Text Areas : PlainText

Possible Answers :

5 to 5.001

Question Number : 26 Question Id : 70819118329 Question Type : SA

Correct Marks : 4 Wrong Marks : 0

ଗୋଟିଏ ଅକ୍ଷରରେ ବିଦ୍ୟୁତ୍ କ୍ଷେତ୍ର  $\vec{E} = \left( \frac{3}{5} E_0 \hat{i} + \frac{4}{5} E_0 \hat{j} \right) \frac{N}{C}$  ଦ୍ୱାରା ଦିଆଯାଇଛି ।  $0.2 \text{ m}^2$  ପୃଷ୍ଠତଳ ବିଶିଷ୍ଟ ଆୟତକାର

ପୃଷ୍ଠଭୂମି ( $y-z$  ସମତଳକୁ ସମାନ୍ତର ଥିବା) ଏବଂ  $0.3 \text{ m}^2$  ପୃଷ୍ଠତଳ ବିଶିଷ୍ଟ ପୃଷ୍ଠଭୂମି ( $x-z$  ସମତଳକୁ ସମାନ୍ତର ଥିବା) ମଧ୍ୟ ଦେଇ ଯାଇଥିବା ବର୍ଣ୍ଣିତ କ୍ଷେତ୍ରର ଅବିବାହ (ଫ୍ଲକ୍ସ)ର ଅନୁପାତ  $a : b$  ଅଟେ, ଯେଉଁଠି  $a = \underline{\hspace{2cm}}$  ଅଟେ ।

(ଏଠାରେ  $\hat{i}$ ,  $\hat{j}$  ଏବଂ  $\hat{k}$  ଯଥାକ୍ରମେ  $x$ ,  $y$  ଏବଂ  $z$ - ଅକ୍ଷ ଦିଗରେ ଥିବା ଏକକ ସଦିଶ)

Response Type : Numeric

Evaluation Required For SA : Yes

Show Word Count : Yes

Answers Type : Range

Text Areas : PlainText

Possible Answers :

5 to 5.001

Question Number : 27 Question Id : 70819118330 Question Type : SA

Correct Marks : 4 Wrong Marks : 0

A transmitting station releases waves of wavelength 960 m. A capacitor of  $2.56 \mu\text{F}$  is used in the resonant circuit. The self inductance of coil necessary for resonance is  $\underline{\hspace{2cm}} \times 10^{-8} \text{ H}$ .

Response Type : Numeric

Evaluation Required For SA : Yes

Show Word Count : Yes

Answers Type : Range

Text Areas : PlainText

Possible Answers :

5 to 5.001

Question Number : 27 Question Id : 70819118330 Question Type : SA

Correct Marks : 4 Wrong Marks : 0

ଗୋଟିଏ ସଂଚାର କେନ୍ଦ୍ର 960 m ଚରଙ୍ଗ ଦୈର୍ଘ୍ୟ ବିଶିଷ୍ଟ ଚରଙ୍ଗ ଛାଡ଼ୁଛି । ଅନୁନାଦ ପରିପଥରେ 2.56  $\mu\text{F}$  ଗୋଟିଏ ପାରସ୍ପରିକ ବ୍ୟବହାର କରାଯାଇଛି । ଅନୁନାଦ (ରିଜୋନାନ୍ସ) ପାଇଁ ଆବଶ୍ୟକ ପଡୁଥିବା କୁଣ୍ଡଳୀର ସ୍ୱପ୍ରଣୋଦକତା ହେଉଛି \_\_\_\_\_  $\times 10^{-8}$  H ।

**Response Type :** Numeric

**Evaluation Required For SA :** Yes

**Show Word Count :** Yes

**Answers Type :** Range

**Text Areas :** PlainText

**Possible Answers :**

5 to 5.001

**Question Number :** 28 **Question Id :** 70819118331 **Question Type :** SA

**Correct Marks :** 4 **Wrong Marks :** 0

The same size images are formed by a convex lens when the object is placed at 20 cm or at 10 cm from the lens. The focal length of convex lens is \_\_\_\_\_ cm.

**Response Type :** Numeric

**Evaluation Required For SA :** Yes

**Show Word Count :** Yes

**Answers Type :** Range

**Text Areas :** PlainText

**Possible Answers :**

5 to 5.001

**Question Number :** 28 **Question Id :** 70819118331 **Question Type :** SA

**Correct Marks :** 4 **Wrong Marks :** 0

ଯେତେବେଳେ ଗୋଟିଏ ବସ୍ତୁକୁ ଏକ ଉତ୍ତଳ ଯବକାଚ ଠାରୁ 20 cm କିମ୍ବା 10 cm ଦୂରତାରେ ରଖାଯାଏ, ସମାନ ଆକାରର ପ୍ରତିବିମ୍ବ ସୃଷ୍ଟି ହୋଇଥାଏ । ଉତ୍ତଳ ଯବକାଚଟିର ଫୋକସ୍ ଦୈର୍ଘ୍ୟ ହେଉଛି \_\_\_\_\_ cm ।

**Response Type :** Numeric

**Evaluation Required For SA :** Yes

**Show Word Count :** Yes

**Answers Type :** Range

**Text Areas :** PlainText

**Possible Answers :**

5 to 5.001

**Question Number : 29 Question Id : 70819118332 Question Type : SA**

**Correct Marks : 4 Wrong Marks : 0**

In a certain thermodynamical process, the pressure of a gas depends on its volume as  $kV^3$ . The work done when the temperature changes from  $100^\circ\text{C}$  to  $300^\circ\text{C}$  will be \_\_\_\_\_  $nR$ , where  $n$  denotes number of moles of a gas.

**Response Type :** Numeric

**Evaluation Required For SA :** Yes

**Show Word Count :** Yes

**Answers Type :** Range

**Text Areas :** PlainText

**Possible Answers :**

5 to 5.001

**Question Number : 29 Question Id : 70819118332 Question Type : SA**

**Correct Marks : 4 Wrong Marks : 0**

ଗୋଟିଏ ନିର୍ଦ୍ଦିଷ୍ଟ ତାପଗତିକ ପ୍ରକ୍ରିୟାରେ, ଗ୍ୟାସର ତାପ ଏହାର ଆୟତନ ଉପରେ  $kV^3$  ଆକାରରେ ନିର୍ଭର କରୁଛି । ଯେତେବେଳେ ତାପମାତ୍ରା  $100^\circ\text{C}$  ରୁ  $300^\circ\text{C}$  କୁ ପରିବର୍ତ୍ତନ ହେବ, କାର୍ଯ୍ୟ ସମ୍ପାଦନ ହେବ \_\_\_\_\_  $nR$ , ଯେଉଁଠି 'n' ଗ୍ୟାସର ମୋଲ ସଂଖ୍ୟାକୁ ଦର୍ଶାଏ ।

**Response Type :** Numeric

**Evaluation Required For SA :** Yes

**Show Word Count :** Yes

**Answers Type :** Range

**Text Areas :** PlainText

**Possible Answers :**

5 to 5.001

**Question Number : 30 Question Id : 70819118333 Question Type : SA**

**Correct Marks : 4 Wrong Marks : 0**

In the given circuit of potentiometer, the potential difference  $E$  across  $AB$  (10 m length) is larger than  $E_1$  and  $E_2$  as well. For key  $K_1$  (closed), the jockey is adjusted to touch the wire at point  $J_1$  so that there is no deflection in the galvanometer. Now the first battery ( $E_1$ ) is replaced by second battery ( $E_2$ ) for working by making  $K_1$  open and  $K_2$  closed. The galvanometer gives then null deflection at  $J_2$ . The value of  $\frac{E_1}{E_2}$  is  $\frac{a}{b}$ , where  $a = \dots$ .

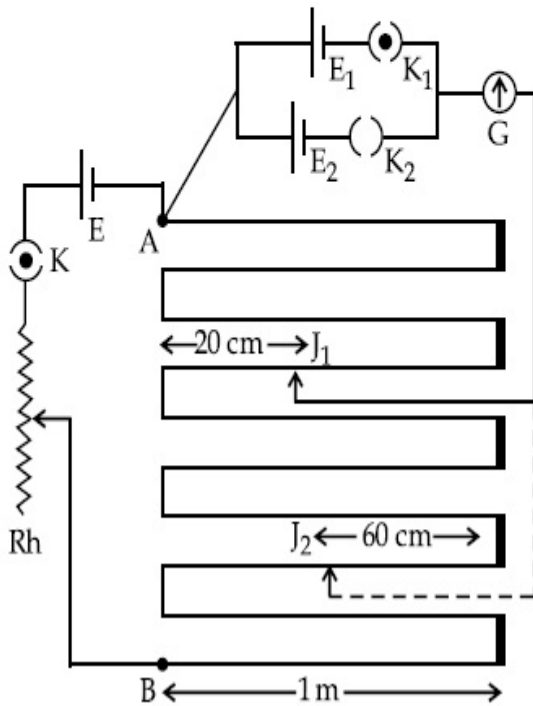

**Response Type :** Numeric

**Evaluation Required For SA :** Yes

**Show Word Count :** Yes

**Answers Type :** Range

**Text Areas :** PlainText

**Possible Answers :**

5 to 5.001

**Question Number :** 30 **Question Id :** 70819118333 **Question Type :** SA

**Correct Marks : 4 Wrong Marks : 0**

ଦତ୍ତ ପୋଟେନ୍ସିଓମିଟରର ପରିପଥରେ, AB (10 m ଦୈର୍ଘ୍ୟ) ର ଦୁଇ ମୁଣ୍ଡ ମଧ୍ୟରେ ଥିବା ବିଭବ ପାର୍ଥକ୍ୟ  $E_1$  ଓ  $E_2$  ଓ ଏବଂ ସେହିପରି  $E_2$  ଠାରୁ ଅଧିକ ଅଟେ । ଚାକି  $K_1$  (ବନ୍ଦ) ପାଇଁ, ଜକିଟିକୁ ଯଥୋପଯୁକ୍ତ ଭାବେ ଚାରର  $J_1$  ବିନ୍ଦୁରେ ସ୍ପର୍ଶ କରାଗଲା ଯଦ୍ୱାରା ଗାଲଭାନୋମିଟରରେ କୌଣସି ବିଚ୍ୟୁତି ହେବ ନାହିଁ । ବର୍ତ୍ତମାନ  $K_1$  କୁ ଖୋଲା ଏବଂ  $K_2$  କୁ ବନ୍ଦ ରଖି ତାକୁ କରିବା ପାଇଁ ପ୍ରଥମ ବ୍ୟାଟେରୀ ( $E_1$ ) କୁ ଦ୍ୱିତୀୟ ବ୍ୟାଟେରୀ ( $E_2$ ) ଦ୍ୱାରା ପ୍ରତିସ୍ଥାପନ କରାଯାଇଛି । ଗାଲଭାନୋମିଟରଟି  $J_2$

ବିନ୍ଦୁରେ ଶୂନ୍ୟ ବିଚ୍ୟୁତି (ନଲ୍ ଡିଫ୍ଲେକ୍ସନ୍) ଦେଖାଇଥାଏ ।  $\frac{E_1}{E_2}$  ର ମୂଲ୍ୟ ହେଉଛି  $\frac{a}{b}$ , ଯେଉଁଠି  $a = \dots$  ଅଟେ ।

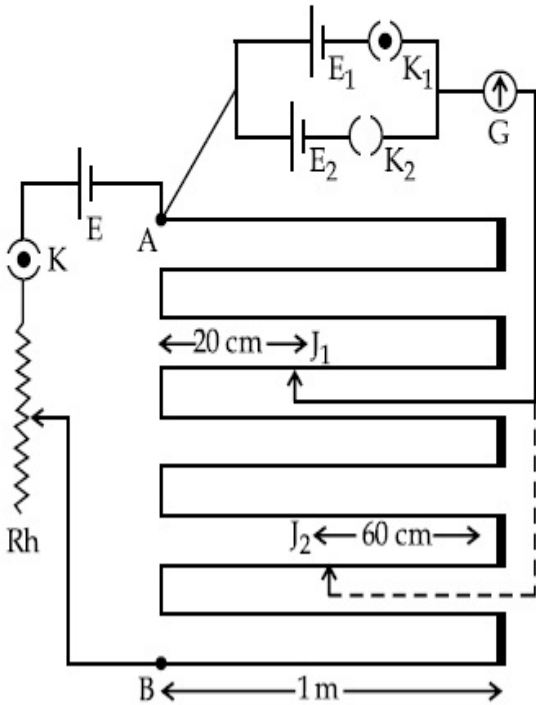

**Response Type :** Numeric

**Evaluation Required For SA :** Yes

**Show Word Count :** Yes

**Answers Type :** Range

**Text Areas :** PlainText

**Possible Answers :**

5 to 5.001

## Chemistry Section A

<b>Section Id :</b>	708191762
<b>Section Number :</b>	3
<b>Section type :</b>	Online
<b>Mandatory or Optional :</b>	Mandatory
<b>Number of Questions :</b>	20

**Number of Questions to be attempted :** 20

**Section Marks :** 80

**Mark As Answered Required? :** Yes

**Sub-Section Number :** 1

**Sub-Section Id :** 7081911042

**Question Shuffling Allowed :** Yes

**Question Number : 31 Question Id : 70819118334 Question Type : MCQ Option Shuffling : Yes**

**Is Question Mandatory : No**

**Correct Marks : 4 Wrong Marks : 1**

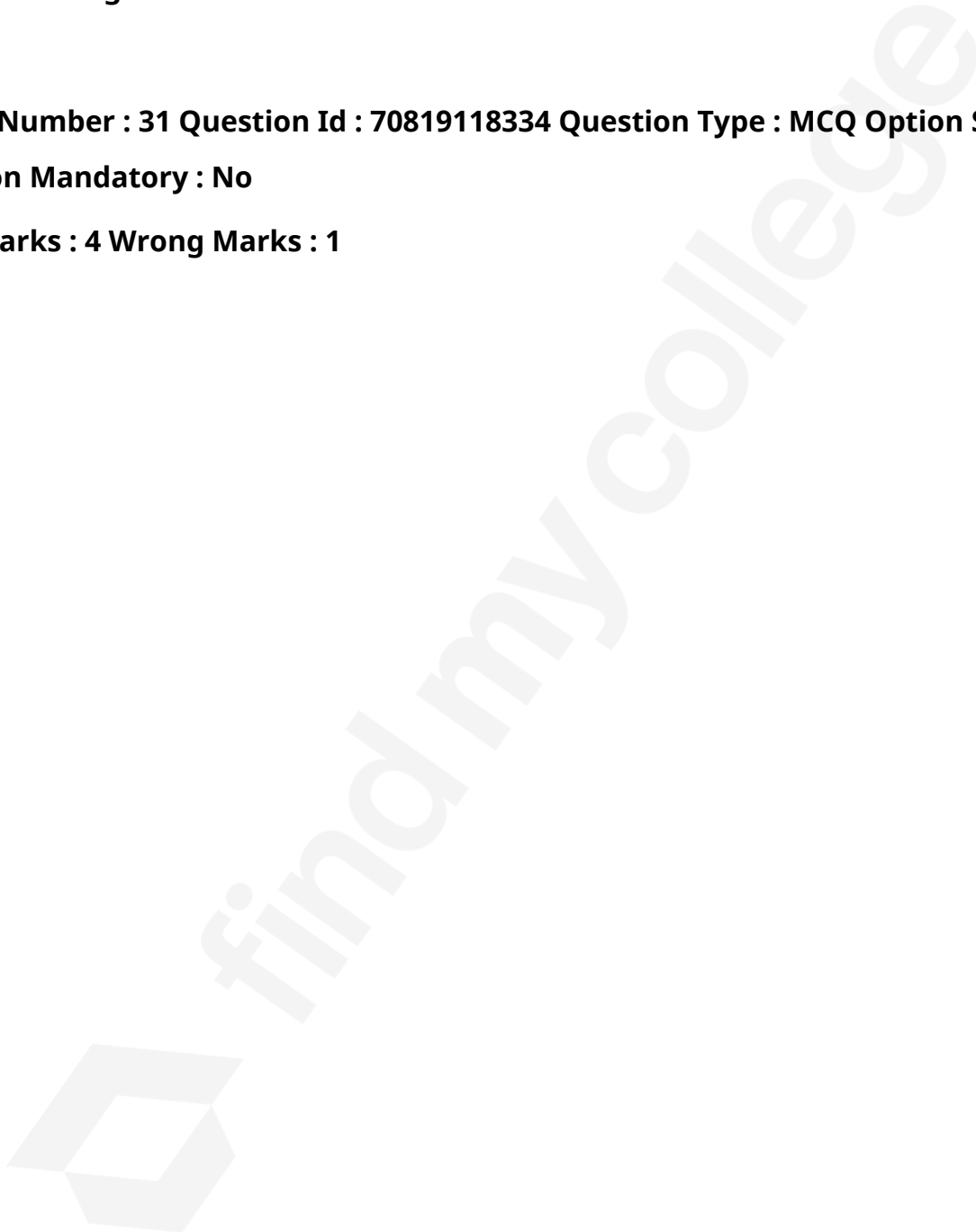

The plots of radial distribution functions for various orbitals of hydrogen atom are given below :

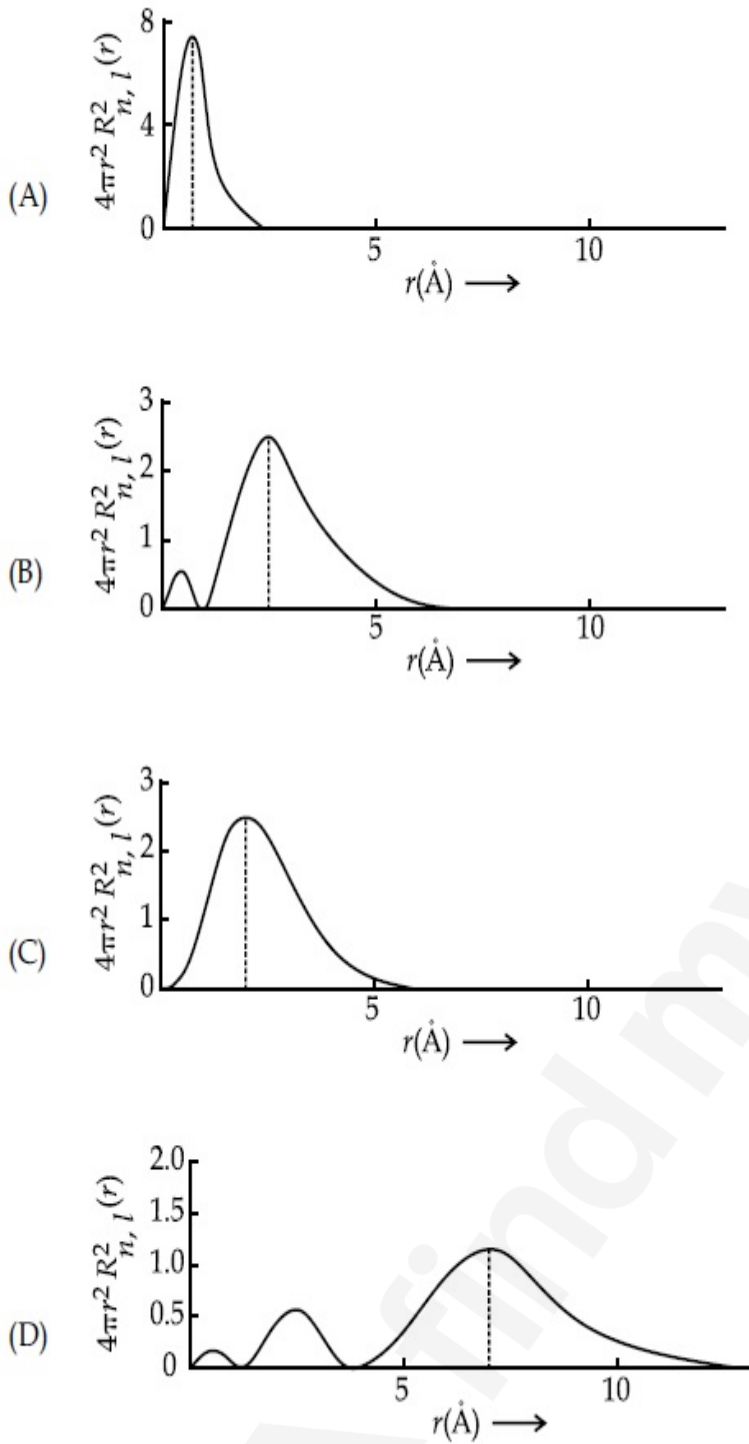

The correct plot for 3s orbital is :

**Options :**

70819160151. (A)

70819160152. (B)

70819160153. (C)

Question Number : 31 Question Id : 70819118334 Question Type : MCQ Option Shuffling : Yes  
Is Question Mandatory : No

Correct Marks : 4 Wrong Marks : 1

ହାଇଡ୍ରୋଜେନ୍ ପରମାଣୁର ବିଭିନ୍ନ କକ୍ଷୀୟ ପଥଗୁଡ଼ିକ ପାଇଁ ରେଡିୟଲ୍ ଡିସ୍ଟ୍ରିବ୍ୟୁସନ୍ ଫଳନ ଗୁଡ଼ିକର 'r' ବିପକ୍ଷରେ ଲେଖାଗିତ୍ତ ଚଳେ ଦିଆଯାଇଛି :

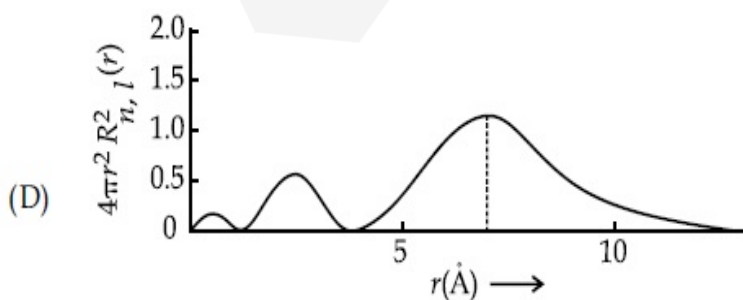
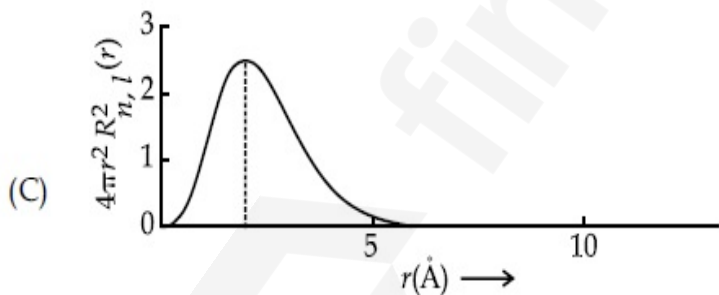
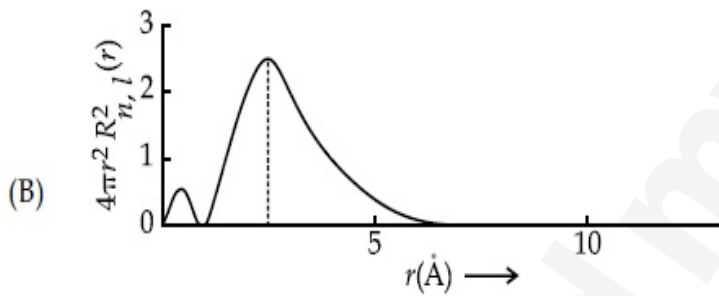
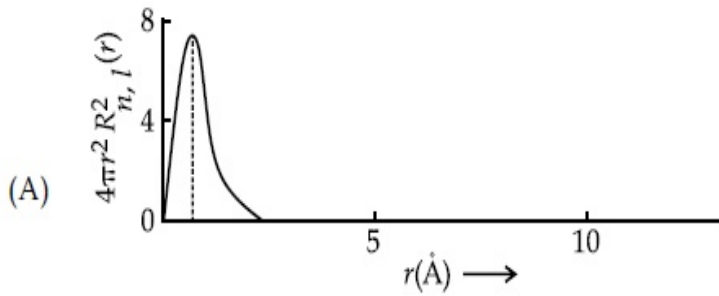

3s କକ୍ଷୀୟ ପାଇଁ ଲେଖାଗିତ୍ତ ଚିତ୍ରଟି ହେଉଛି :

Options :

70819160151. (A)

70819160152. (B)

70819160153. (C)

70819160154. (D)

Question Number : 32 Question Id : 70819118335 Question Type : MCQ Option Shuffling : Yes

Is Question Mandatory : No

Correct Marks : 4 Wrong Marks : 1

According to molecular orbital theory, the species among the following that does not exist is :

Options :

70819160155.  $O_2^{2-}$

70819160156.  $He_2^-$

70819160157.  $Be_2$

70819160158.  $He_2^+$

Question Number : 32 Question Id : 70819118335 Question Type : MCQ Option Shuffling : Yes

Is Question Mandatory : No

Correct Marks : 4 Wrong Marks : 1

ଅଣୁକକ୍ଷକ ତଥ୍ୟ (MOT) ଅନୁସାରେ ନିମ୍ନରୁ କେଉଁ ପ୍ରକାରିର ଅଣୁ ନାହିଁ, ହେଉଛି :

Options :

70819160155.

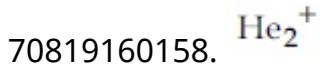
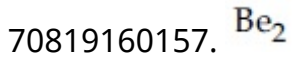
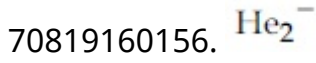

Question Number : 33 Question Id : 70819118336 Question Type : MCQ Option Shuffling : Yes

Is Question Mandatory : No

Correct Marks : 4 Wrong Marks : 1

The solubility of AgCN in a buffer solution of pH=3 is  $x$ . The value of  $x$  is :  
[Assume : No cyano complex is formed ;  $K_{sp}(AgCN) = 2.2 \times 10^{-16}$  and  $K_a(HCN) = 6.2 \times 10^{-10}$ ]

Options :

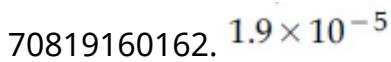
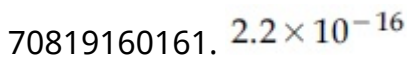
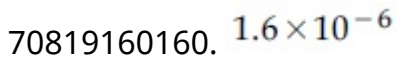
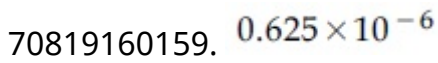

Question Number : 33 Question Id : 70819118336 Question Type : MCQ Option Shuffling : Yes

Is Question Mandatory : No

Correct Marks : 4 Wrong Marks : 1

pH=3 ଥିବା ଏକ ବଫର ଦ୍ରବଣରେ AgCN ର ଦ୍ରବଣୀୟତା ହେଉଛି  $x$  ।  $x$  ର ମୂଲ୍ୟ ହେଉଛି \_\_\_\_\_ । (ଧରାଯାଉ କୌଣସି ସିଆନୋ ସଂକ୍ଳୁକ ଚିଆରି ହୋଇନାହିଁ)

( $K_{sp}(AgCN) = 2.2 \times 10^{-16}$  ଏବଂ  $K_a(HCN) = 6.2 \times 10^{-10}$ )

Options :

70819160159.  $0.625 \times 10^{-6}$

70819160160.  $1.6 \times 10^{-6}$

70819160161.  $2.2 \times 10^{-16}$

70819160162.  $1.9 \times 10^{-5}$

Question Number : 34 Question Id : 70819118337 Question Type : MCQ Option Shuffling : Yes

Is Question Mandatory : No

Correct Marks : 4 Wrong Marks : 1

In Freundlich adsorption isotherm at moderate pressure, the extent of adsorption  $\left(\frac{x}{m}\right)$  is directly proportional to  $P^x$ . The value of  $x$  is :

Options :

70819160163. 1

70819160164. zero

70819160165.  $\infty$

70819160166.  $\frac{1}{n}$

Question Number : 34 Question Id : 70819118337 Question Type : MCQ Option Shuffling : Yes

Is Question Mandatory : No

Correct Marks : 4 Wrong Marks : 1

$x$  ର ମୂଲ୍ୟ ହେଉଛି :

**Options :**

70819160163. 1

70819160164. zero

70819160165.  $\infty$

70819160166.  $\frac{1}{n}$

**Question Number : 35 Question Id : 70819118338 Question Type : MCQ Option Shuffling : Yes**

**Is Question Mandatory : No**

**Correct Marks : 4 Wrong Marks : 1**

Ellingham diagram is a graphical representation of :

**Options :**

70819160167.  $\Delta G$  vs T

70819160168.  $\Delta H$  vs T

70819160169.  $\Delta G$  vs P

70819160170.  $(\Delta G - T\Delta S)$  vs T

**Question Number : 35 Question Id : 70819118338 Question Type : MCQ Option Shuffling : Yes**

**Is Question Mandatory : No**

**Correct Marks : 4 Wrong Marks : 1**

ଏଲିକ୍ଟ୍ରୋଲାଇଟ୍ ଚିତ୍ର ନିର୍ଦ୍ଦେଶନା କରେ :

**Options :**

70819160167.  $\Delta G$  vs T

70819160168.  $\Delta H$  vs T

70819160169.  $\Delta G$  vs P

70819160170.  $(\Delta G - T\Delta S)$  vs T

**Question Number : 36 Question Id : 70819118339 Question Type : MCQ Option Shuffling : Yes**

**Is Question Mandatory : No**

**Correct Marks : 4 Wrong Marks : 1**

Which of the following equation depicts the oxidizing nature of  $H_2O_2$  ?

**Options :**

70819160171.  $KIO_4 + H_2O_2 \rightarrow KIO_3 + H_2O + O_2$

70819160172.  $I_2 + H_2O_2 + 2OH^- \rightarrow 2I^- + 2H_2O + O_2$

70819160173.  $2I^- + H_2O_2 + 2H^+ \rightarrow I_2 + 2H_2O$

70819160174.  $Cl_2 + H_2O_2 \rightarrow 2HCl + O_2$

**Question Number : 36 Question Id : 70819118339 Question Type : MCQ Option Shuffling : Yes**

**Is Question Mandatory : No**

**Correct Marks : 4 Wrong Marks : 1**

ନିମ୍ନଲିଖିତ ସମୀକରଣ ମଧ୍ୟରୁ କେଉଁଟି  $H_2O_2$  ର ଜାରକାରୀ ଗୁଣକୁ ବର୍ଣ୍ଣନା କରେ ?

**Options :**

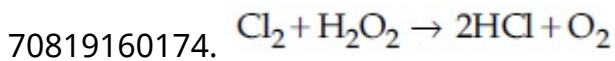
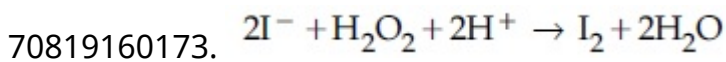
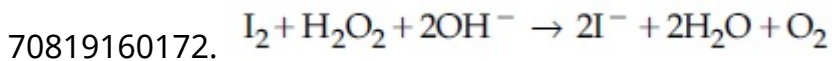
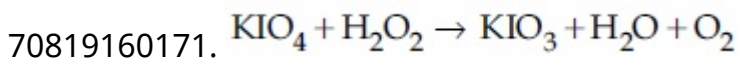

Question Number : 37 Question Id : 70819118340 Question Type : MCQ Option Shuffling : Yes

Is Question Mandatory : No

Correct Marks : 4 Wrong Marks : 1

The correct statement about  $\text{B}_2\text{H}_6$  is :

Options :

70819160175. All B–H–B angles are of  $120^\circ$ .

70819160176. The two B–H–B bonds are not of same length.

70819160177. Terminal B–H bonds have less  $p$ -character when compared to bridging bonds.

70819160178. Its fragment,  $\text{BH}_3$ , behaves as a Lewis base.

Question Number : 37 Question Id : 70819118340 Question Type : MCQ Option Shuffling : Yes

Is Question Mandatory : No

Correct Marks : 4 Wrong Marks : 1

$\text{B}_2\text{H}_6$  ପାଇଁ ସଠିକ୍ ଉକ୍ତିଟି ହେଉଛି :

Options :

70819160175. ସମସ୍ତ B–H–B କୋଣ  $120^\circ$  ।

70819160176. ଦୁଇଟି B—H—B ବନ୍ଧର ଲମ୍ବା ସମାନ ନୁହଁ ।

70819160177. ପ୍ରାକ୍ରିୟା(ଚେମିକାଲ) B—H ବନ୍ଧର *p*-ଗୁଣ ସେତୁ (ବ୍ରିଜିଙ୍ଗ) ବନ୍ଧଠାରୁ କମ୍ ।

70819160178. ଏହାର ଏକ ଅଂଶ  $BH_3$ , ଲୁଇସ୍ କ୍ଷାର ପରି ବ୍ୟବହାର ଦେଖାଏ ।

**Question Number : 38 Question Id : 70819118341 Question Type : MCQ Option Shuffling : Yes**

**Is Question Mandatory : No**

**Correct Marks : 4 Wrong Marks : 1**

Given below are two statements :

Statement I :  $CeO_2$  can be used for oxidation of aldehydes and ketones.

Statement II : Aqueous solution of  $EuSO_4$  is a strong reducing agent.

In the light of the above statements, choose the correct answer from the options given below :

**Options :**

70819160179. Both Statement I and Statement II are true

70819160180. Both Statement I and Statement II are false

70819160181. Statement I is true but Statement II is false

70819160182. Statement I is false but Statement II is true

**Question Number : 38 Question Id : 70819118341 Question Type : MCQ Option Shuffling : Yes**

**Is Question Mandatory : No**

**Correct Marks : 4 Wrong Marks : 1**

ନିମ୍ନରେ ଦୁଇଟି ଉକ୍ତି ଦିଆଯାଇଛି :

ଉକ୍ତି- I : ଏଲଡିହାଇଡସ୍ ଏବଂ କିଟୋନ୍ସ ମାନଙ୍କର ଜାରଣ ପାଇଁ  $CeO_2$  ବ୍ୟବହାର କରାଯାଇପାରିବ ।

ଉକ୍ତି- II :  $EuSO_4$  ର ଜଳୀୟ ଦ୍ରବଣ ଏକ ତୀବ୍ର (ସ୍ତ୍ରୋଙ୍ଗ) ବିଜାରକ ।

ଉପରୋକ୍ତ ଉକ୍ତି ଉଭିରେ ସବୁଠାରୁ ଉପଯୁକ୍ତ ଉତ୍ତରକୁ ନିମ୍ନ ବିକଳ୍ପରୁ ବାଛି :

**Options :**

70819160179. ଉଭୟ ଉଚ୍ଚ I ଏବଂ II ଠିକ୍ ।

70819160180. ଉଭୟ ଉଚ୍ଚ I ଏବଂ II ଭୁଲ୍ ।

70819160181. ଉଚ୍ଚ I ଠିକ୍ କିନ୍ତୁ ଉଚ୍ଚ II ଭୁଲ୍ ।

70819160182. ଉଚ୍ଚ I ଭୁଲ୍ କିନ୍ତୁ ଉଚ୍ଚ II ଠିକ୍ ।

**Question Number : 39 Question Id : 70819118342 Question Type : MCQ Option Shuffling : Yes**

**Is Question Mandatory : No**

**Correct Marks : 4 Wrong Marks : 1**

In which of the following pairs, the outer most electronic configuration will be the same ?

**Options :**

70819160183.  $V^{2+}$  and  $Cr^+$

70819160184.  $Cr^+$  and  $Mn^{2+}$

70819160185.  $Ni^{2+}$  and  $Cu^+$

70819160186.  $Fe^{2+}$  and  $Co^+$

**Question Number : 39 Question Id : 70819118342 Question Type : MCQ Option Shuffling : Yes**

**Is Question Mandatory : No**

**Correct Marks : 4 Wrong Marks : 1**

ନିମ୍ନଲିଖିତ ଯୋଡ଼ା ମଧ୍ୟରୁ କାହାର ବାହ୍ୟତମ ଇଲେକ୍ଟ୍ରନ୍‌ଗଣ ବିନ୍ୟାସ ସମାନ ହେବ ?

**Options :**

70819160183.  $V^{2+}$  and  $Cr^+$

70819160184.  $\text{Cr}^+$  and  $\text{Mn}^{2+}$

70819160185.  $\text{Ni}^{2+}$  and  $\text{Cu}^+$

70819160186.  $\text{Fe}^{2+}$  and  $\text{Co}^+$

Question Number : 40 Question Id : 70819118343 Question Type : MCQ Option Shuffling : Yes

Is Question Mandatory : No

Correct Marks : 4 Wrong Marks : 1

The hybridization and magnetic nature of  $[\text{Mn}(\text{CN})_6]^{4-}$  and  $[\text{Fe}(\text{CN})_6]^{3-}$ , respectively are :

Options :

70819160187.  $d^2sp^3$  and paramagnetic

70819160188.  $sp^3d^2$  and diamagnetic

70819160189.  $d^2sp^3$  and diamagnetic

70819160190.  $sp^3d^2$  and paramagnetic

Question Number : 40 Question Id : 70819118343 Question Type : MCQ Option Shuffling : Yes

Is Question Mandatory : No

Correct Marks : 4 Wrong Marks : 1

$[\text{Mn}(\text{CN})_6]^{4-}$  ଏବଂ  $[\text{Fe}(\text{CN})_6]^{3-}$  ର ସଂକରଣ ଏବଂ ରୁମ୍‌କାୟ ପ୍ରକୃତି ଯଥାକ୍ରମେ :

Options :

70819160187.  $d^2sp^3$  ଏବଂ ଅନୁରୁମ୍‌କାୟ

70819160188.  $sp^3d^2$  ଏବଂ ପ୍ରତିରୁମ୍‌କାୟ

70819160189.  $d^2sp^3$  ଏବଂ ପ୍ରତିରୁମକାୟ

70819160190.  $sp^3d^2$  ଏବଂ ଅନୁରୁମକାୟ

**Question Number : 41 Question Id : 70819118344 Question Type : MCQ Option Shuffling : Yes**  
**Is Question Mandatory : No**

**Correct Marks : 4 Wrong Marks : 1**

Given below are two statements :

**Statement I :** An allotrope of oxygen is an important intermediate in the formation of reducing smog.

**Statement II :** Gases such as oxides of nitrogen and sulphur present in troposphere contribute to the formation of photochemical smog.

In the light of the above statements, choose the correct answer from the options given below :

**Options :**

70819160191. Both Statement I and Statement II are true

70819160192. Both Statement I and Statement II are false

70819160193. Statement I is true but Statement II is false

70819160194. Statement I is false but Statement II is true

**Question Number : 41 Question Id : 70819118344 Question Type : MCQ Option Shuffling : Yes**  
**Is Question Mandatory : No**

**Correct Marks : 4 Wrong Marks : 1**

ତଳେ ଦୁଇଟି ଉକ୍ତି ଦିଆଯାଇଛି :

**ଉକ୍ତି - I :** ସ୍ମଗ୍ ବିଜାରଣା ପଦ୍ଧତି ବେଳେ ଅକ୍ସିଜେନ୍ ଅପରରୂପୀ ଏକ ଜରୁରୀ ମଧ୍ୟବର୍ତ୍ତୀ ପଦାର୍ଥ ଅଟେ ।

**ଉକ୍ତି - II :** ଟ୍ରୋପୋସ୍ଫିଅରରେ ଥିବା ନାଇଟ୍ରୋଜେନ୍ ଏବଂ ସଲ୍ଫରର ଅକ୍ସାଇଡ୍ ପରି ବାଷ୍ପ ଆଲୋକ ରାସାୟନିକ ସ୍ମଗ୍ ଚିଆରିରେ ସାହାଯ୍ୟ କରନ୍ତି ।

ଉପରୋକ୍ତ ଉକ୍ତି ଦିଗରେ ସବୁଠାରୁ ଉପଯୁକ୍ତ ଉତ୍ତରକୁ ନିମ୍ନ ବିକଳ୍ପ ମଧ୍ୟରୁ ବାଛି :

Options :

70819160191. ଉଭୟ ଉକ୍ତି I ଏବଂ II ଠିକ୍

70819160192. ଉଭୟ ଉକ୍ତି I ଏବଂ II ଭୁଲ୍

70819160193. ଉକ୍ତି I ଠିକ୍ କିନ୍ତୁ ଉକ୍ତି II ଭୁଲ୍

70819160194. ଉକ୍ତି I ଭୁଲ୍ କିନ୍ତୁ ଉକ୍ତି II ଠିକ୍

Question Number : 42 Question Id : 70819118345 Question Type : MCQ Option Shuffling : Yes

Is Question Mandatory : No

Correct Marks : 4 Wrong Marks : 1

Complete combustion of 1.80 g of an oxygen containing compound ( $C_xH_yO_z$ ) gave 2.64 g of  $CO_2$  and 1.08 g of  $H_2O$ . The percentage of oxygen in the organic compound is :

Options :

70819160195. 50.33

70819160196. 53.33

70819160197. 63.53

70819160198. 51.63

Question Number : 42 Question Id : 70819118345 Question Type : MCQ Option Shuffling : Yes

Is Question Mandatory : No

Correct Marks : 4 Wrong Marks : 1

ଅକ୍ସିଜେନ୍ ଧାରଣ କରିଥିବା 1.80 ଗ୍ରାମର ଯୌଗିକ ( $C_xH_yO_z$ ) ର ସମ୍ପୂର୍ଣ୍ଣ ଦହନରେ 2.64 ଗ୍ରାମ  $CO_2$  ଏବଂ 1.08 ଗ୍ରାମ  $H_2O$  ଦିଏ । ଜୈବ ଯୌଗିକରେ ଅକ୍ସିଜେନ୍ ର ଶତକଡ଼ା (%) ହେଉଛି :

Options :

70819160195. 50.33

70819160196. 53.33

70819160197. 63.53

70819160198. 51.63

Question Number : 43 Question Id : 70819118346 Question Type : MCQ Option Shuffling : Yes

Is Question Mandatory : No

Correct Marks : 4 Wrong Marks : 1

Identify A in the given chemical reaction.

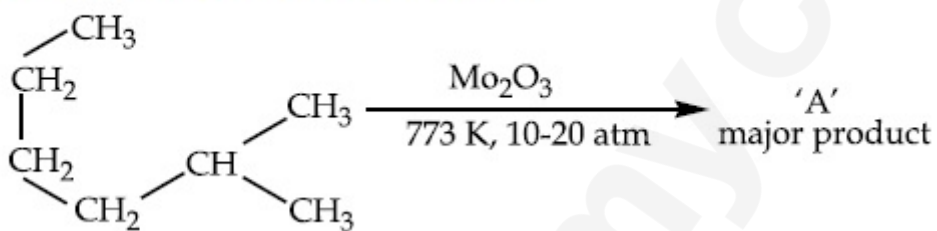

Options :

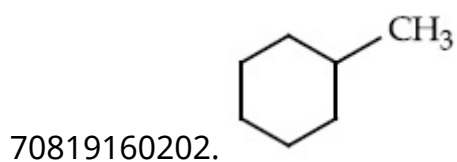
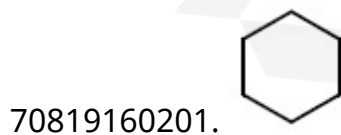
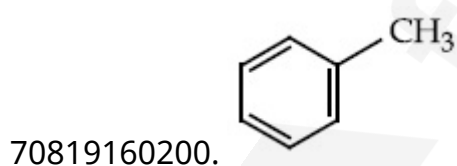
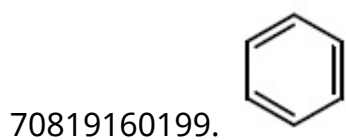

Question Number : 43 Question Id : 70819118346 Question Type : MCQ Option Shuffling : Yes

Is Question Mandatory : No

Correct Marks : 4 Wrong Marks : 1

ରାସାୟନିକ ପ୍ରତିକ୍ରିୟାଟିରେ A କୁ ଚିହ୍ନଟାଅ ।

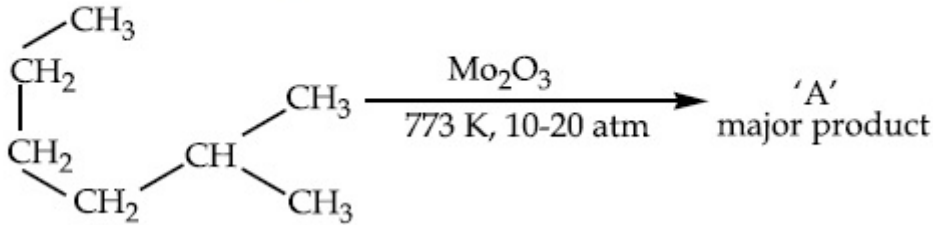

Options :

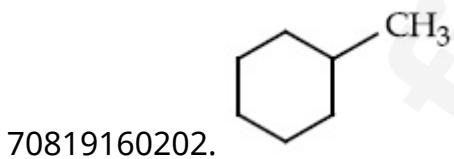
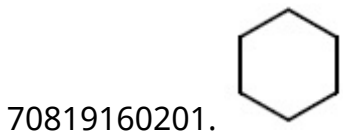
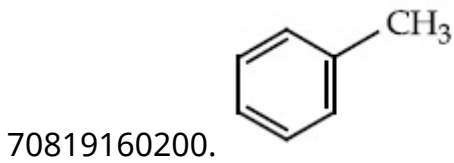
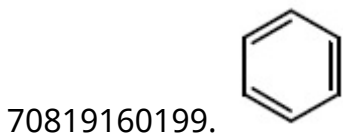

Question Number : 44 Question Id : 70819118347 Question Type : MCQ Option Shuffling : Yes

Is Question Mandatory : No

Correct Marks : 4 Wrong Marks : 1

Identify A and B in the chemical reaction.

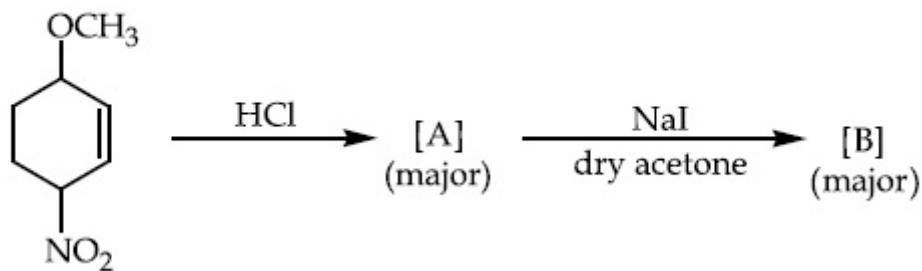

Options :

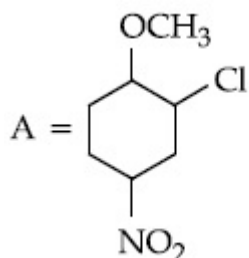

70819160203.

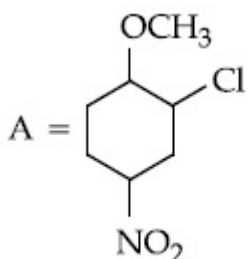
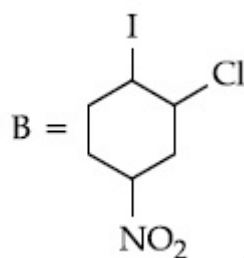

70819160204.

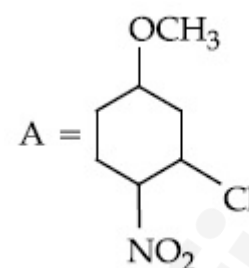
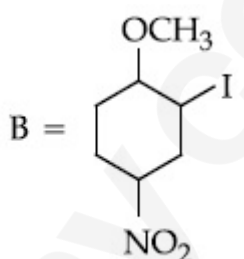

70819160205.

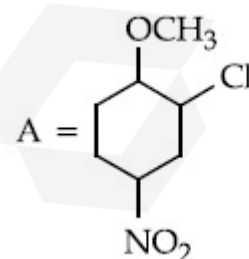
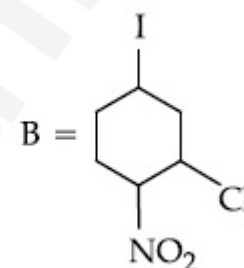

70819160206.

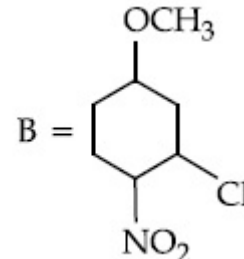

ରାସାୟନିକ ପ୍ରତିକ୍ରିୟାଟିରେ A ଏବଂ B କୁ ଚିହ୍ନଟାଅ ।

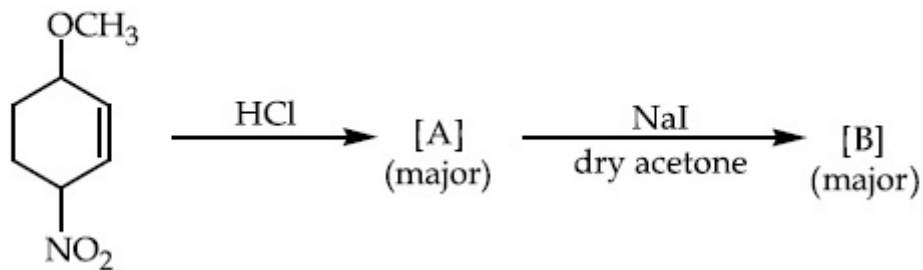

Options :

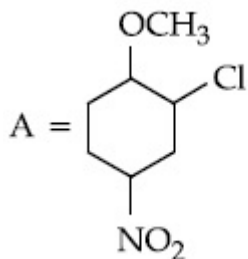

70819160203.

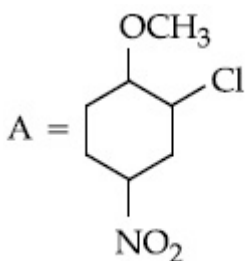
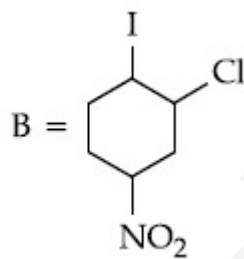

70819160204.

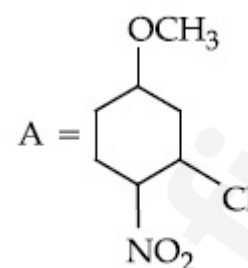
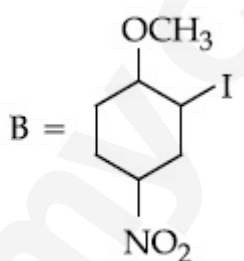

70819160205.

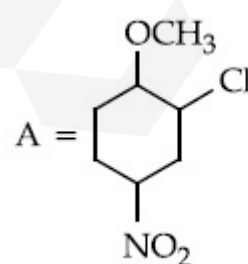
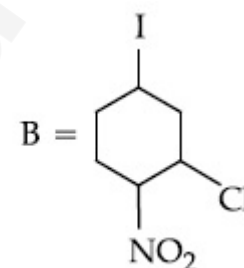

70819160206.

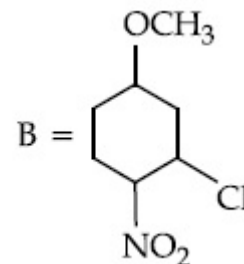

Is Question Mandatory : No

Correct Marks : 4 Wrong Marks : 1

The major product of the following chemical reaction is :

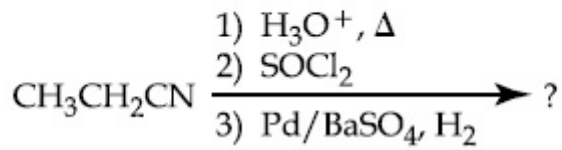

Options :

70819160207.  $\text{CH}_3\text{CH}_2\text{CH}_2\text{OH}$

70819160208.  $(\text{CH}_3\text{CH}_2\text{CO})_2\text{O}$

70819160209.  $\text{CH}_3\text{CH}_2\text{CH}_3$

70819160210.  $\text{CH}_3\text{CH}_2\text{CHO}$

Question Number : 45 Question Id : 70819118348 Question Type : MCQ Option Shuffling : Yes

Is Question Mandatory : No

Correct Marks : 4 Wrong Marks : 1

ନିମ୍ନ ରାସାୟନିକ ପ୍ରତିକ୍ରିୟାଟିର ମୁଖ୍ୟ ଉତ୍ପାଦଟି ହେଉଛି :

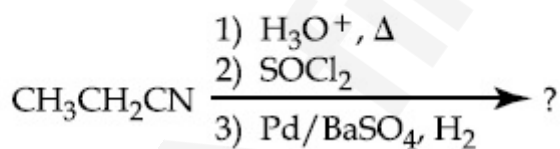

Options :

70819160207.  $\text{CH}_3\text{CH}_2\text{CH}_2\text{OH}$

70819160208.  $(\text{CH}_3\text{CH}_2\text{CO})_2\text{O}$

70819160209.  $\text{CH}_3\text{CH}_2\text{CH}_3$

70819160210.  $\text{CH}_3\text{CH}_2\text{CHO}$

**Question Number : 46 Question Id : 70819118349 Question Type : MCQ Option Shuffling : Yes Is Question Mandatory : No**

**Correct Marks : 4 Wrong Marks : 1**

Which one of the following reactions will not form acetaldehyde ?

**Options :**

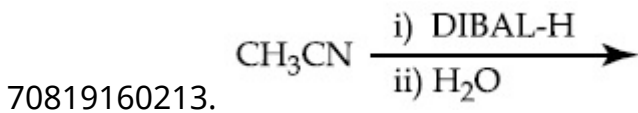
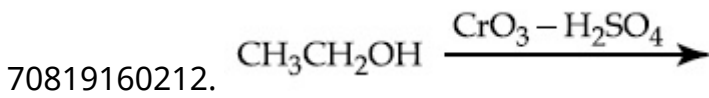
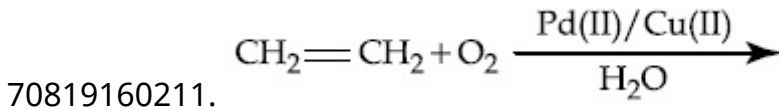

**Question Number : 46 Question Id : 70819118349 Question Type : MCQ Option Shuffling : Yes Is Question Mandatory : No**

**Correct Marks : 4 Wrong Marks : 1**

ନିମ୍ନ ପ୍ରତିକ୍ରିୟା ଗୁଡ଼ିକରୁ କେଉଁଟି ଏସିଟାଲଡିହାଇଡ୍ର ପ୍ରସ୍ତୁତ କରିବ ନାହିଁ ?

**Options :**

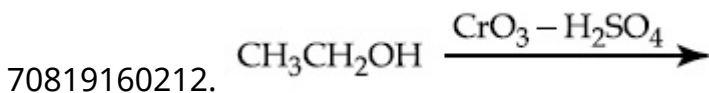
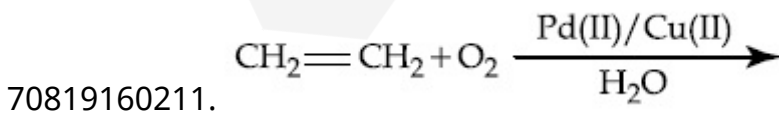

70819160213.

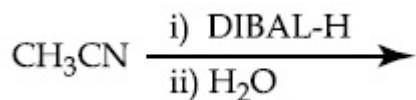

70819160214.

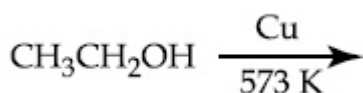

Question Number : 47 Question Id : 70819118350 Question Type : MCQ Option Shuffling : Yes

Is Question Mandatory : No

Correct Marks : 4 Wrong Marks : 1

Compound(s) which will liberate carbon dioxide with sodium bicarbonate solution is/are :

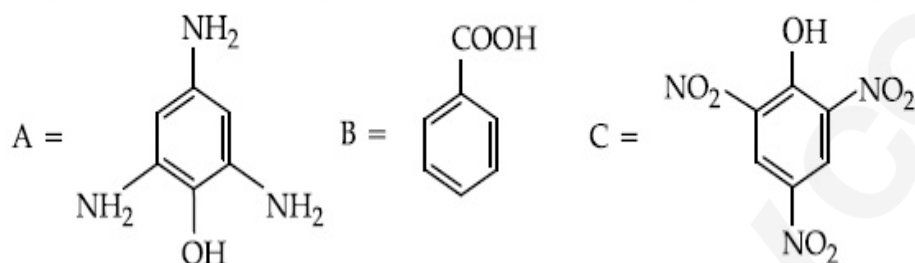

Options :

70819160215. A and B only

70819160216. C only

70819160217. B and C only

70819160218. B only

Question Number : 47 Question Id : 70819118350 Question Type : MCQ Option Shuffling : Yes

Is Question Mandatory : No

Correct Marks : 4 Wrong Marks : 1

ସୋଡ଼ିୟମ୍ ବାଇକାର୍ବୋନେଟ୍ ଦ୍ରବଣରୁ ଅଜ୍ଵାରକାୟ ନିର୍ଗତ କରୁଥିବା ଯୌଗିକ (ଗୁଡ଼ିକ) ହେଉଛି :

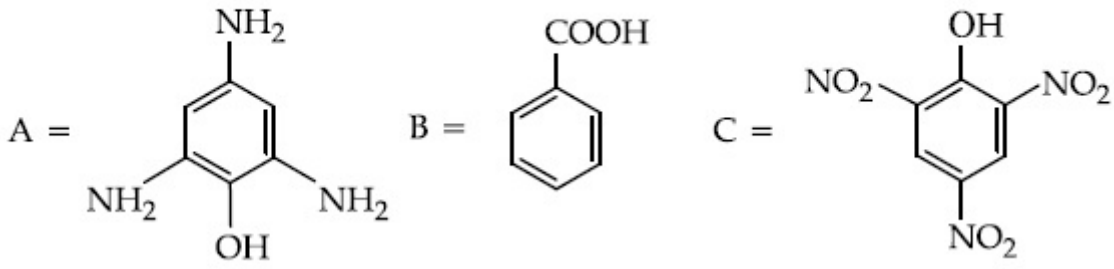

Options :

70819160215. A ଏବଂ B

70819160216. କେବଳ C

70819160217. B ଏବଂ C

70819160218. କେବଳ B

Question Number : 48 Question Id : 70819118351 Question Type : MCQ Option Shuffling : Yes

Is Question Mandatory : No

Correct Marks : 4 Wrong Marks : 1

Which of the following reaction/s will not give *p*-aminoazobenzene ?

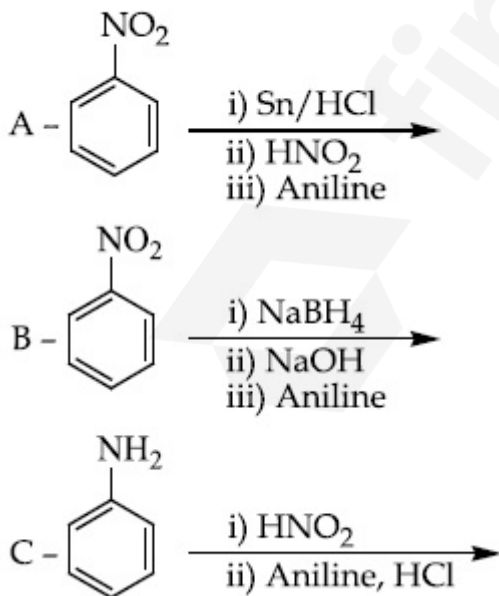

Options :

70819160219. A only

70819160220. C only

70819160221. B only

70819160222. A and B

Question Number : 48 Question Id : 70819118351 Question Type : MCQ Option Shuffling : Yes

Is Question Mandatory : No

Correct Marks : 4 Wrong Marks : 1

ନିମ୍ନଲିଖିତ କେଉଁ ପ୍ରତିକ୍ରିୟା (ଗୁଡ଼ିକ) *p*- ଏମିନୋ ଆଲୋ ବେଞ୍ଜିନ୍ ଦିଏ ନାହିଁ ?

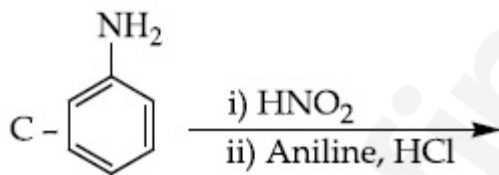
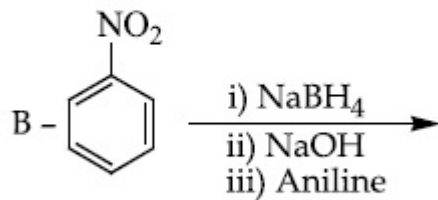
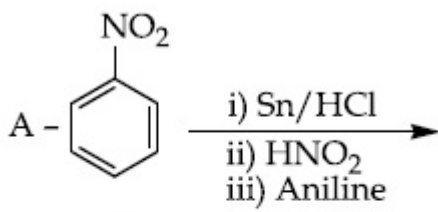

Options :

70819160219. କେବଳ A

70819160220. କେବଳ C

70819160221. କେବଳ B

70819160222. A ଏବଂ B

Question Number : 49 Question Id : 70819118352 Question Type : MCQ Option Shuffling : Yes

Is Question Mandatory : No

Correct Marks : 4 Wrong Marks : 1

Which statement is correct ?

Options :

70819160223. Buna-N is a natural polymer.

70819160224. Buna-S is a synthetic and linear thermosetting polymer.

70819160225. Neoprene is an addition copolymer used in plastic bucket manufacturing.

70819160226. Synthesis of Buna-S needs nascent oxygen.

Question Number : 49 Question Id : 70819118352 Question Type : MCQ Option Shuffling : Yes

Is Question Mandatory : No

Correct Marks : 4 Wrong Marks : 1

କେଉଁ ଗୋଟିକ ଠିକ୍ ?

Options :

70819160223. ବୁନା - N ଏକ ପ୍ରାକୃତିକ ବହୁଳକ ।

70819160224. ବୁନା - S ଏକ ସଂଶ୍ଳେଷିତ ଏବଂ ରୈଖିକ ଅର୍ମୋସେଟିଙ୍ଗ ବହୁଳକ ।

70819160225. ନିଓପ୍ରିନ୍ ଏକ ଯୋଗାତ୍ମକ ସହ ବହୁଳକ ଯାହା ପ୍ଲାଷ୍ଟିକ୍ ବାଲ୍ଟି ଉତ୍ପାଦନରେ ବ୍ୟବହୃତ ହୁଏ ।

70819160226. ବୁନା - S ସଂଶ୍ଳେଷଣରେ ନେସେଣ୍ଟ ଅକ୍ସିଜେନ୍ ଦରକାର ।

Question Number : 50 Question Id : 70819118353 Question Type : MCQ Option Shuffling : Yes

Is Question Mandatory : No

Correct Marks : 4 Wrong Marks : 1

Which of the glycosidic linkage between galactose and glucose is present in lactose ?

Options :

70819160227. C-1 of galactose and C-4 of glucose

70819160228. C-1 of galactose and C-6 of glucose

70819160229. C-1 of glucose and C-4 of galactose

70819160230. C-1 of glucose and C-6 of galactose

Question Number : 50 Question Id : 70819118353 Question Type : MCQ Option Shuffling : Yes

Is Question Mandatory : No

Correct Marks : 4 Wrong Marks : 1

ଲାଇଟୋଜରେ ଥିବା ଗାଲକ୍ଟୋଜ୍ ଏବଂ ଗ୍ଲୁକୋଜ୍ ମଧ୍ୟରେ କେଉଁ ଗ୍ଲାଇକୋସିଡିକ୍ ସଂଯୋଗଟି ଅଛି ?

Options :

70819160227. ଗାଲକ୍ଟୋଜ୍‌ର C-1 ଏବଂ ଗ୍ଲୁକୋଜ୍‌ର C-4

70819160228. ଗାଲକ୍ଟୋଜ୍‌ର C-1 ଏବଂ ଗ୍ଲୁକୋଜ୍‌ର C-6

70819160229. ଗ୍ଲୁକୋଜ୍‌ର C-1 ଏବଂ ଗାଲକ୍ଟୋଜ୍‌ର C-4

70819160230. ଗ୍ଲୁକୋଜ୍‌ର C-1 ଏବଂ ଗାଲକ୍ଟୋଜ୍‌ର C-6

Section Id : 708191763  
Section Number : 4  
Section type : Online  
Mandatory or Optional : Mandatory  
Number of Questions : 10  
Number of Questions to be attempted : 5  
Section Marks : 20  
Mark As Answered Required? : Yes  
Sub-Section Number : 1  
Sub-Section Id : 7081911043  
Question Shuffling Allowed : Yes

Question Number : 51 Question Id : 70819118354 Question Type : SA

Correct Marks : 4 Wrong Marks : 0

0.4 g mixture of NaOH, Na<sub>2</sub>CO<sub>3</sub> and some inert impurities was first titrated with  $\frac{N}{10}$  HCl using phenolphthalein as an indicator, 17.5 mL of HCl was required at the end point. After this methyl orange was added and titrated. 1.5 mL of same HCl was required for the next end point. The weight percentage of Na<sub>2</sub>CO<sub>3</sub> in the mixture is \_\_\_\_\_. (Rounded-off to the nearest integer)

Response Type : Numeric

Evaluation Required For SA : Yes

Show Word Count : Yes

Answers Type : Range

Text Areas : PlainText

Possible Answers :

5 to 5.001

Question Number : 51 Question Id : 70819118354 Question Type : SA

Correct Marks : 4 Wrong Marks : 0

NaOH ଏବଂ  $\text{Na}_2\text{CO}_3$  ଏବଂ କିଛି ନିଶ୍ଚିତ ଅଣୁକ ପଦାର୍ଥର 0.4 ଗ୍ରାମ ମିଶ୍ରଣ ପ୍ରଥମେ  $\frac{N}{10}$  HCl ଏବଂ ଫନଲପଥାଲିନ୍

ସହିତ ଚାଲିଯିବ କରାଗଲା । ଅନ୍ତ୍ୟକ୍ଷେତ୍ରରେ 17.5 mL HCl ଦରକାର କଲା । ତାପରେ ମିଥାଇଲ୍ ଅରେଜି ମିଶାଗଲା ଏବଂ ପରବର୍ତ୍ତୀ ଅନ୍ତ୍ୟକ୍ଷେତ୍ର ପାଇଁ 1.5 mL ସେହି ସମାନ HCl ଦରକାର ହେଲା ।  $\text{Na}_2\text{CO}_3$  ର ଶତକଡ଼ା ଓଜନ ମିଶ୍ରଣରେ ହେଉଛି \_\_\_\_\_ ।

(ନିକଟତମ ପୂର୍ଣ୍ଣସଂଖ୍ୟାରେ ପରିଣତ କର)

**Response Type :** Numeric

**Evaluation Required For SA :** Yes

**Show Word Count :** Yes

**Answers Type :** Range

**Text Areas :** PlainText

**Possible Answers :**

5 to 5.001

**Question Number :** 52 **Question Id :** 70819118355 **Question Type :** SA

**Correct Marks :** 4 **Wrong Marks :** 0

A car tyre is filled with nitrogen gas at 35 psi at 27°C. It will burst if pressure exceeds 40 psi. The temperature in °C at which the car tyre will burst is \_\_\_\_\_. (Rounded-off to the nearest integer)

**Response Type :** Numeric

**Evaluation Required For SA :** Yes

**Show Word Count :** Yes

**Answers Type :** Range

**Text Areas :** PlainText

**Possible Answers :**

5 to 5.001

**Question Number :** 52 **Question Id :** 70819118355 **Question Type :** SA

**Correct Marks :** 4 **Wrong Marks :** 0

ଏକ କାରର ଟାଇରରେ ନାଇଟ୍ରୋଜେନ୍ ଗ୍ୟାସ୍ 27°C ଏବଂ 35 psi ରେ ଭର୍ତ୍ତି କରାଗଲା । ଯଦି ତାପ 40 psi ଅତିକ୍ରମ କରିବ ଏହା ଫାଟିଯିବ । କାର ଟାଇର ଫାଟିବାର ତାପମାତ୍ରା °C ରେ ହେଉଛି \_\_\_\_\_ ।

**Response Type :** Numeric

**Evaluation Required For SA :** Yes

**Show Word Count :** Yes

**Answers Type :** Range

**Text Areas :** PlainText

**Possible Answers :**

5 to 5.001

**Question Number :** 53 **Question Id :** 70819118356 **Question Type :** SA

**Correct Marks :** 4 **Wrong Marks :** 0

The reaction of cyanamide,  $\text{NH}_2\text{CN}_{(s)}$  with oxygen was run in a bomb calorimeter and  $\Delta U$  was found to be  $-742.24 \text{ kJ mol}^{-1}$ . The magnitude of  $\Delta H_{298}$  for the reaction

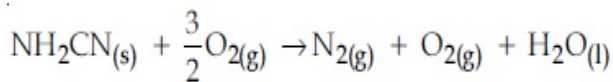

is \_\_\_\_\_ kJ. (Rounded off to the nearest integer)

[Assume ideal gases and  $R = 8.314 \text{ J mol}^{-1} \text{ K}^{-1}$ ]

**Response Type :** Numeric

**Evaluation Required For SA :** Yes

**Show Word Count :** Yes

**Answers Type :** Range

**Text Areas :** PlainText

**Possible Answers :**

5 to 5.001

**Question Number :** 53 **Question Id :** 70819118356 **Question Type :** SA

**Correct Marks :** 4 **Wrong Marks :** 0

ସ୍ୟାନାମାଇଡ୍,  $\text{NH}_2\text{CN}_{(s)}$  ସହିତ ଅକ୍ସିଜେନ୍ ପ୍ରତିକ୍ରିୟା ଗୋଟିଏ ବମ୍ବ କେଲୋରିମିଟରରେ କରାଗଲା ଏବଂ ଦେଖାଗଲା  $\Delta U$  ହେଉଛି  $-742.24 \text{ kJ mol}^{-1}$  ।

$\text{NH}_2\text{CN}_{(s)} + \frac{3}{2}\text{O}_{2(g)} \rightarrow \text{N}_{2(g)} + \text{O}_{2(g)} + \text{H}_2\text{O}_{(l)}$  ପ୍ରତିକ୍ରିୟା ପାଇଁ  $\Delta H_{298}$  ର ଦୈର୍ଘ୍ୟସୂଚକ ହେଉଛି

\_\_\_\_\_ kJ । (ନିକଟତମ ପୂର୍ଣ୍ଣସଂଖ୍ୟାରେ ପରିଣତ କର)

(ଆଦର୍ଶ ଗ୍ୟାସ୍ ବୋଲି ଗ୍ରହଣ କର ଏବଂ  $R = 8.314 \text{ J mol}^{-1} \text{ K}^{-1}$ )

**Response Type :** Numeric

**Evaluation Required For SA :** Yes

**Show Word Count :** Yes

**Answers Type :** Range

**Text Areas :** PlainText

**Possible Answers :**

5 to 5.001

**Question Number :** 54 **Question Id :** 70819118357 **Question Type :** SA

**Correct Marks :** 4 **Wrong Marks :** 0

1 molal aqueous solution of an electrolyte  $A_2B_3$  is 60% ionised. The boiling point of the solution at 1 atm is \_\_\_\_\_ K. (Rounded-off to the nearest integer)

[Given  $K_b$  for  $(H_2O) = 0.52 \text{ K kg mol}^{-1}$ ]

**Response Type :** Numeric

**Evaluation Required For SA :** Yes

**Show Word Count :** Yes

**Answers Type :** Range

**Text Areas :** PlainText

**Possible Answers :**

5 to 5.001

**Question Number :** 54 **Question Id :** 70819118357 **Question Type :** SA

**Correct Marks :** 4 **Wrong Marks :** 0

$A_2B_3$  ଇଲେକ୍ଟ୍ରୋଲାଇଟ୍‌ର 1 ମୋଲାର ଜଳୀୟ ଦ୍ରବଣ 60% ଆୟୋନୀକରଣ ହୁଏ । 1 atm ରେ ଦ୍ରବଣର ସ୍ତୁରଣାଙ୍କ ହେଉଛି \_\_\_\_\_ K । (ନିକଟତମ ପୂର୍ଣ୍ଣସଂଖ୍ୟାରେ ପରିଣତ କର)

(ପ୍ରଦତ୍ତ :  $K_b$  for  $(H_2O) = 0.52 \text{ K kg mol}^{-1}$ )

**Response Type :** Numeric

**Evaluation Required For SA :** Yes

**Show Word Count :** Yes

**Answers Type :** Range

**Text Areas :** PlainText

**Possible Answers :**

**Question Number : 55 Question Id : 70819118358 Question Type : SA**

**Correct Marks : 4 Wrong Marks : 0**

In basic medium  $\text{CrO}_4^{2-}$  oxidises  $\text{S}_2\text{O}_3^{2-}$  to form  $\text{SO}_4^{2-}$  and itself changes into  $\text{Cr}(\text{OH})_4^-$ .

The volume of 0.154 M  $\text{CrO}_4^{2-}$  required to react with 40 mL of 0.25 M  $\text{S}_2\text{O}_3^{2-}$  is \_\_\_\_\_ mL. (Rounded-off to the nearest integer)

**Response Type : Numeric**

**Evaluation Required For SA : Yes**

**Show Word Count : Yes**

**Answers Type : Range**

**Text Areas : PlainText**

**Possible Answers :**

5 to 5.001

**Question Number : 55 Question Id : 70819118358 Question Type : SA**

**Correct Marks : 4 Wrong Marks : 0**

କ୍ଷାରୀୟ ମାଧ୍ୟମରେ  $\text{CrO}_4^{2-}$ ,  $\text{S}_2\text{O}_3^{2-}$  କୁ ଜାରଣ କରି  $\text{SO}_4^{2-}$  ଗଠନ କରେ ଏବଂ ନିଜେ  $\text{Cr}(\text{OH})_4^-$  କୁ ପରିବର୍ତ୍ତିତ ହୁଏ । 40 mL 0.25 M  $\text{S}_2\text{O}_3^{2-}$ , 0.154 M  $\text{CrO}_4^{2-}$  ସହିତ ପ୍ରତିକ୍ରିୟା କରିବା ପାଇଁ ଦରକାର କରୁଥିବା ଆୟତନ ହେଉଛି \_\_\_\_\_ mL । (ନିକଟତମ ପୂର୍ଣ୍ଣ ସଂଖ୍ୟାରେ ପରିଣତ କର)

**Response Type : Numeric**

**Evaluation Required For SA : Yes**

**Show Word Count : Yes**

**Answers Type : Range**

**Text Areas : PlainText**

**Possible Answers :**

5 to 5.001

**Question Number : 56 Question Id : 70819118359 Question Type : SA**

Correct Marks : 4 Wrong Marks : 0

For the reaction,  $aA + bB \rightarrow cC + dD$ , the plot of  $\log k$  vs  $\frac{1}{T}$  is given below :

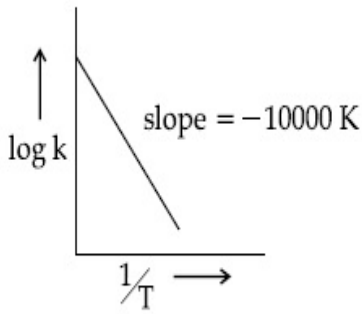

The temperature at which the rate constant of the reaction is  $10^{-4} \text{ s}^{-1}$  is \_\_\_\_\_ K.  
(Rounded-off to the nearest integer)

[Given : The rate constant of the reaction is  $10^{-5} \text{ s}^{-1}$  at 500 K.]

Response Type : Numeric

Evaluation Required For SA : Yes

Show Word Count : Yes

Answers Type : Range

Text Areas : PlainText

Possible Answers :

5 to 5.001

Question Number : 56 Question Id : 70819118359 Question Type : SA

Correct Marks : 4 Wrong Marks : 0

ପ୍ରତିକ୍ରିୟା  $aA + bB \rightarrow cC + dD$  ପାଇଁ  $\log k$  vs  $\frac{1}{T}$  ର ଲେଖାଚିତ୍ରଟି ତଳେ ଦିଆଯାଇଛି ।

ଯେଉଁ ତାପମାତ୍ରାରେ ଏହି ପ୍ରତିକ୍ରିୟାର ହାର ସ୍ଥିରାଙ୍କ  $10^{-4} \text{ s}^{-1}$ , ତାହା ହେଉଛି \_\_\_\_\_ K ।

(ନିକଟତମ ପୂର୍ଣ୍ଣ ସଂଖ୍ୟାରେ ପରିଣତ କର)

ପ୍ରଦତ୍ତ : ପ୍ରତିକ୍ରିୟାର ହାର ସ୍ଥିରାଙ୍କ 500 K ରେ ହେଉଛି  $10^{-5} \text{ s}^{-1}$  ।

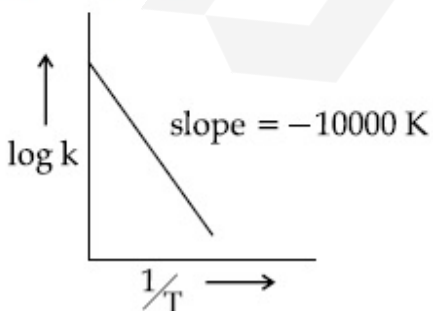

Response Type : Numeric

Evaluation Required For SA : Yes

Show Word Count : Yes

Answers Type : Range

Text Areas : PlainText

Possible Answers :

5 to 5.001

Question Number : 57 Question Id : 70819118360 Question Type : SA

Correct Marks : 4 Wrong Marks : 0

The ionization enthalpy of  $\text{Na}^+$  formation from  $\text{Na}_{(g)}$  is  $495.8 \text{ kJ mol}^{-1}$ , while the electron gain enthalpy of Br is  $-325.0 \text{ kJ mol}^{-1}$ . Given the lattice enthalpy of NaBr is  $-728.4 \text{ kJ mol}^{-1}$ . The energy for the formation of NaBr ionic solid is  $(-)\_\_\_\_\_\_ \times 10^{-1} \text{ kJ mol}^{-1}$ .

Response Type : Numeric

Evaluation Required For SA : Yes

Show Word Count : Yes

Answers Type : Range

Text Areas : PlainText

Possible Answers :

5 to 5.001

Question Number : 57 Question Id : 70819118360 Question Type : SA

Correct Marks : 4 Wrong Marks : 0

$\text{Na}_{(g)}$  ରୁ  $\text{Na}^+$  ଗଠନ ପାଇଁ ଆୟୋନାଇଜେସନ୍ ଏନ୍ଥାଲପି ହେଉଛି  $495.8 \text{ kJ mol}^{-1}$  । ଅପରପକ୍ଷରେ Br ର ଇଲେକ୍ଟ୍ରନ୍ ଗେନ୍ ଏନ୍ଥାଲପି ହେଉଛି  $-325.0 \text{ kJ mol}^{-1}$  । NaBrର ଲାଟିସ୍ ଏନ୍ଥାଲପି ଦିଆଯାଇଛି  $-728.4 \text{ kJ mol}^{-1}$  । NaBr ଆୟୋନିକ୍ କଠିନ ବସ୍ତୁ ଗଠନ ପାଇଁ ଶକ୍ତି ହେଉଛି  $(-)\_\_\_\_\_\_ \times 10^{-1} \text{ kJ mol}^{-1}$  ।

Response Type : Numeric

Evaluation Required For SA : Yes

Show Word Count : Yes

Answers Type : Range

Text Areas : PlainText

Possible Answers :

5 to 5.001

Question Number : 58 Question Id : 70819118361 Question Type : SA

Correct Marks : 4 Wrong Marks : 0

Among the following, the number of halide(s) which is/are inert to hydrolysis is \_\_\_\_\_.

(A)  $\text{BF}_3$  (B)  $\text{SiCl}_4$  (C)  $\text{PCl}_5$  (D)  $\text{SF}_6$

Response Type : Numeric

Evaluation Required For SA : Yes

Show Word Count : Yes

Answers Type : Range

Text Areas : PlainText

Possible Answers :

5 to 5.001

Question Number : 58 Question Id : 70819118361 Question Type : SA

Correct Marks : 4 Wrong Marks : 0

ନିମ୍ନଲିଖିତ ହାଲାଇଡ୍ (ମାନକ) ମଧ୍ୟରୁ ଯେଉଁ (ଗୁଡ଼ିକ) ଜଳ ଅପସରଣ ପ୍ରକ୍ରିୟା ପ୍ରତି ନିଷ୍ପ୍ରଭ ତାଙ୍କ ସଂଖ୍ୟା ହେଉଛି \_\_\_\_\_ ।

(A)  $\text{BF}_3$  (B)  $\text{SiCl}_4$  (C)  $\text{PCl}_5$  (D)  $\text{SF}_6$

Response Type : Numeric

Evaluation Required For SA : Yes

Show Word Count : Yes

Answers Type : Range

Text Areas : PlainText

Possible Answers :

5 to 5.001

Question Number : 59 Question Id : 70819118362 Question Type : SA

Correct Marks : 4 Wrong Marks : 0

Consider the following chemical reaction.

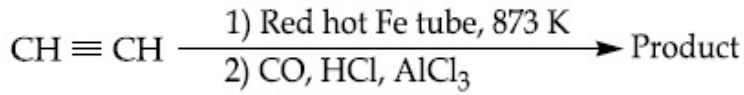

The number of  $sp^2$  hybridized carbon atom(s) present in the product is \_\_\_\_\_.

**Response Type :** Numeric

**Evaluation Required For SA :** Yes

**Show Word Count :** Yes

**Answers Type :** Range

**Text Areas :** PlainText

**Possible Answers :**

5 to 5.001

**Question Number :** 59 **Question Id :** 70819118362 **Question Type :** SA

**Correct Marks :** 4 **Wrong Marks :** 0

ନିମ୍ନ ରାସାୟନିକ ପ୍ରତିକ୍ରିୟାଟିକୁ ବିଚାରକୁ ନିଅ ।

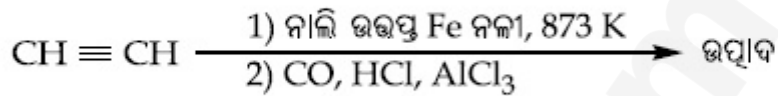

ଉତ୍ପାଦରେ ଥିବା  $sp^2$  ସଂକରିତ କାର୍ବନ୍ ପରମାଣୁ ଗୁଡ଼ିକର ସଂଖ୍ୟା ହେଉଛି \_\_\_\_\_ ।

**Response Type :** Numeric

**Evaluation Required For SA :** Yes

**Show Word Count :** Yes

**Answers Type :** Range

**Text Areas :** PlainText

**Possible Answers :**

5 to 5.001

**Question Number :** 60 **Question Id :** 70819118363 **Question Type :** SA

**Correct Marks :** 4 **Wrong Marks :** 0

Using the provided information in the following paper chromatogram:

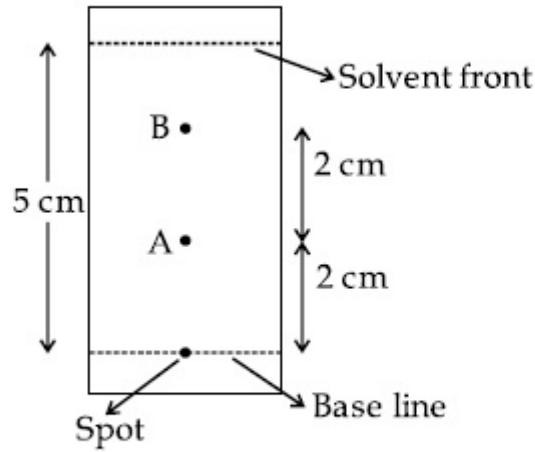

Fig : Paper chromatography for compounds A and B, the calculated  $R_f$  value of A \_\_\_\_\_  $\times 10^{-1}$ .

Response Type : Numeric

Evaluation Required For SA : Yes

Show Word Count : Yes

Answers Type : Range

Text Areas : PlainText

Possible Answers :

5 to 5.001

Question Number : 60 Question Id : 70819118363 Question Type : SA

Correct Marks : 4 Wrong Marks : 0

ନିମ୍ନରେ ଦିଆଯାଇଥିବା ଯେପରି କ୍ରୋମାଟୋଗ୍ରାଫ୍ ସୂଚନାକୁ ବ୍ୟବହାର କରି :

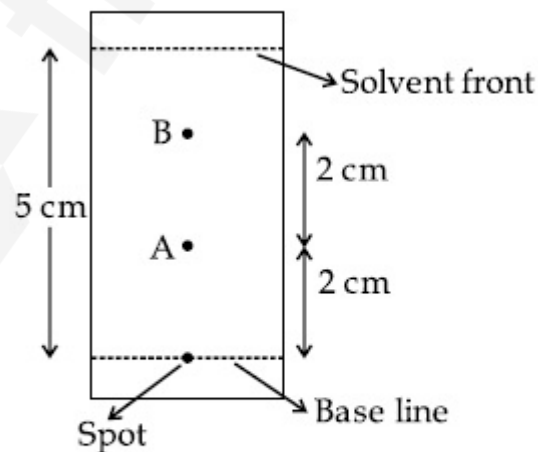

Fig : A ଏବଂ B ଯୌଗିକର ଯେପରି କ୍ରୋମାଟୋଗ୍ରାଫି

A ର ଗଣନାତ୍ମକ  $R_f$  ମୂଲ୍ୟ ହେଉଛି \_\_\_\_\_  $\times 10^{-1}$  ।

Response Type : Numeric

Evaluation Required For SA : Yes

Show Word Count : Yes

Answers Type : Range

Text Areas : PlainText

Possible Answers :

5 to 5.001

## Mathematics Section A

Section Id :	708191764
Section Number :	5
Section type :	Online
Mandatory or Optional :	Mandatory
Number of Questions :	20
Number of Questions to be attempted :	20
Section Marks :	80
Mark As Answered Required? :	Yes
Sub-Section Number :	1
Sub-Section Id :	7081911044
Question Shuffling Allowed :	Yes

Question Number : 61 Question Id : 70819118364 Question Type : MCQ Option Shuffling : Yes

Is Question Mandatory : No

Correct Marks : 4 Wrong Marks : 1

Let  $f, g : \mathbb{N} \rightarrow \mathbb{N}$  such that  $f(n+1) = f(n) + f(1) \forall n \in \mathbb{N}$  and  $g$  be any arbitrary function. Which of the following statements is NOT true ?

Options :

70819160241. If  $f$  is onto, then  $f(n) = n \forall n \in \mathbb{N}$

70819160242.  $f$  is one-one

70819160243. If  $g$  is onto, then  $f \circ g$  is one-one

70819160244. If  $f \circ g$  is one-one, then  $g$  is one-one

**Question Number : 61 Question Id : 70819118364 Question Type : MCQ Option Shuffling : Yes**

**Is Question Mandatory : No**

**Correct Marks : 4 Wrong Marks : 1**

ମନେକର  $f, g : \mathbb{N} \rightarrow \mathbb{N}$ , ଯେପରିକି  $f(n+1) = f(n) + f(1) \forall n \in \mathbb{N}$  ଦୁଇଟି ଫଳନ ଏବଂ  $g$  ଏକ ଇଞ୍ଜେକ୍ସନ୍ ଫଳନ ।

ନିମ୍ନରେ ଥିବା କେଉଁ ଉକ୍ତି (କଥନ)ଟି ସତ ନୁହେଁ ?

**Options :**

70819160241. ଯଦି  $f$  ଅନୁରୂପ, ତେବେ  $f(n) = n \forall n \in \mathbb{N}$

70819160242.  $f$  ଏକ-ଏକ ଅଟେ

70819160243. ଯଦି  $g$  ଅନୁରୂପ, ତେବେ  $f \circ g$  ଏକ-ଏକ

70819160244. ଯଦି  $f \circ g$  ଏକ-ଏକ, ତେବେ  $g$  ଏକ-ଏକ

**Question Number : 62 Question Id : 70819118365 Question Type : MCQ Option Shuffling : Yes**

**Is Question Mandatory : No**

**Correct Marks : 4 Wrong Marks : 1**

Let the lines  $(2 - i)z = (2 + i)\bar{z}$  and  $(2 + i)z + (i - 2)\bar{z} - 4i = 0$ , (here  $i^2 = -1$ ) be normal to a circle  $C$ . If the line  $iz + \bar{z} + 1 + i = 0$  is tangent to this circle  $C$ , then its radius is :

**Options :**

70819160245.  $3\sqrt{2}$

70819160246.  $\frac{1}{2\sqrt{2}}$

70819160247.  $\frac{3}{2\sqrt{2}}$

70819160248.  $\frac{3}{\sqrt{2}}$

**Question Number : 62 Question Id : 70819118365 Question Type : MCQ Option Shuffling : Yes**

**Is Question Mandatory : No**

**Correct Marks : 4 Wrong Marks : 1**

ମନେକର  $(2 - i)z = (2 + i)\bar{z}$  ଓ  $(2 + i)z + (i - 2)\bar{z} - 4i = 0$ , ( $i^2 = -1$ ) ରେଖାଦ୍ୱାରା ଏକ ବୃତ୍ତ C ପ୍ରତି  
ଲମ୍ବ । ଯଦି ରେଖା  $iz + \bar{z} + 1 + i = 0$  ଉକ୍ତ ବୃତ୍ତ C ର ସ୍ପର୍ଶକ, ତେବେ ଏହାର ବ୍ୟାସାର୍ଦ୍ଧ ଅଟେ :

**Options :**

70819160245.  $3\sqrt{2}$

70819160246.  $\frac{1}{2\sqrt{2}}$

70819160247.  $\frac{3}{2\sqrt{2}}$

70819160248.  $\frac{3}{\sqrt{2}}$

**Question Number : 63 Question Id : 70819118366 Question Type : MCQ Option Shuffling : Yes**

**Is Question Mandatory : No**

**Correct Marks : 4 Wrong Marks : 1**

The integer 'k', for which the inequality  $x^2 - 2(3k - 1)x + 8k^2 - 7 > 0$  is valid for every x in R,  
is :

Options :

70819160249. 2

70819160250. 3

70819160251. 4

70819160252. 0

Question Number : 63 Question Id : 70819118366 Question Type : MCQ Option Shuffling : Yes

Is Question Mandatory : No

Correct Marks : 4 Wrong Marks : 1

ପୂର୍ଣ୍ଣସଂଖ୍ୟା “k” ଯାହା ପାଇଁ  $x^2 - 2(3k - 1)x + 8k^2 - 7 > 0$  ଅସମୀକରଣଟି ବୈଧ (ସଙ୍ଗତ), (ପ୍ରତ୍ୟେକ ବାସ୍ତବ ସଂଖ୍ୟା x ପାଇଁ) ଚାହା ଅଟେ :

Options :

70819160249. 2

70819160250. 3

70819160251. 4

70819160252. 0

Question Number : 64 Question Id : 70819118367 Question Type : MCQ Option Shuffling : Yes

Is Question Mandatory : No

Correct Marks : 4 Wrong Marks : 1

If  $0 < \theta, \phi < \frac{\pi}{2}$ ,  $x = \sum_{n=0}^{\infty} \cos^{2n} \theta$ ,  $y = \sum_{n=0}^{\infty} \sin^{2n} \phi$  and  $z = \sum_{n=0}^{\infty} \cos^{2n} \theta \cdot \sin^{2n} \phi$  then :

Options :

70819160253.  $xy - z = (x + y)z$

70819160254.  $xy + z = (x + y)z$

70819160255.  $xy + yz + zx = z$

70819160256.  $xyz = 4$

Question Number : 64 Question Id : 70819118367 Question Type : MCQ Option Shuffling : Yes

Is Question Mandatory : No

Correct Marks : 4 Wrong Marks : 1

$$\text{Given } 0 < \theta, \phi < \frac{\pi}{2}, x = \sum_{n=0}^{\infty} \cos^{2n} \theta, y = \sum_{n=0}^{\infty} \sin^{2n} \phi \text{ and } z = \sum_{n=0}^{\infty} \cos^{2n} \theta \cdot \sin^{2n} \phi :$$

Options :

70819160253.  $xy - z = (x + y)z$

70819160254.  $xy + z = (x + y)z$

70819160255.  $xy + yz + zx = z$

70819160256.  $xyz = 4$

Question Number : 65 Question Id : 70819118368 Question Type : MCQ Option Shuffling : Yes

Is Question Mandatory : No

Correct Marks : 4 Wrong Marks : 1

If Rolle's theorem holds for the function  $f(x) = x^3 - ax^2 + bx - 4$ ,  $x \in [1, 2]$  with  $f' \left( \frac{4}{3} \right) = 0$ ,

then ordered pair (a, b) is equal to :

Options :

70819160257. (5, 8)

70819160258. (5, -8)

70819160259. (-5, 8)

70819160260. (-5, -8)

**Question Number : 65 Question Id : 70819118368 Question Type : MCQ Option Shuffling : Yes**

**Is Question Mandatory : No**

**Correct Marks : 4 Wrong Marks : 1**

ଯଦି ରୋଲ୍‌ଙ୍କ ଉପପାଦ୍ୟଟି, ଫଳନ  $f(x) = x^3 - ax^2 + bx - 4$ ,  $x \in [1, 2]$  ପାଇଁ  $(f'(\frac{4}{3}) = 0$  ସହିତ) ଉପଯୁକ୍ତ

ଅଟେ, ତେବେ ଶୁଣ୍ଠକ ଯୋଡ଼ି (a, b) ସମାନ୍ :

**Options :**

70819160257. (5, 8)

70819160258. (5, -8)

70819160259. (-5, 8)

70819160260. (-5, -8)

**Question Number : 66 Question Id : 70819118369 Question Type : MCQ Option Shuffling : Yes**

**Is Question Mandatory : No**

**Correct Marks : 4 Wrong Marks : 1**

$$\lim_{n \rightarrow \infty} \left( 1 + \frac{1 + \frac{1}{2} + \dots + \frac{1}{n}}{n^2} \right)^n \text{ is equal to :}$$

Options :

70819160261. 0

70819160262.  $\frac{1}{2}$

70819160263.  $\frac{1}{e}$

70819160264. 1

Question Number : 66 Question Id : 70819118369 Question Type : MCQ Option Shuffling : Yes

Is Question Mandatory : No

Correct Marks : 4 Wrong Marks : 1

$$\lim_{n \rightarrow \infty} \left( 1 + \frac{1 + \frac{1}{2} + \dots + \frac{1}{n}}{n^2} \right)^n \text{ ସମାନ :}$$

Options :

70819160261. 0

70819160262.  $\frac{1}{2}$

70819160263.  $\frac{1}{e}$

70819160264. 1

Question Number : 67 Question Id : 70819118370 Question Type : MCQ Option Shuffling : Yes

Is Question Mandatory : No

Correct Marks : 4 Wrong Marks : 1

The value of the integral

$$\int \frac{\sin\theta \cdot \sin 2\theta (\sin^6\theta + \sin^4\theta + \sin^2\theta) \sqrt{2\sin^4\theta + 3\sin^2\theta + 6}}{1 - \cos 2\theta} d\theta \text{ is :}$$

(where c is a constant of integration)

Options :

70819160265.  $\frac{1}{18} [9 - 2\sin^6\theta - 3\sin^4\theta - 6\sin^2\theta]^{\frac{3}{2}} + c$

70819160266.  $\frac{1}{18} [9 - 2\cos^6\theta - 3\cos^4\theta - 6\cos^2\theta]^{\frac{3}{2}} + c$

70819160267.  $\frac{1}{18} [11 - 18\sin^2\theta + 9\sin^4\theta - 2\sin^6\theta]^{\frac{3}{2}} + c$

70819160268.  $\frac{1}{18} [11 - 18\cos^2\theta + 9\cos^4\theta - 2\cos^6\theta]^{\frac{3}{2}} + c$

Question Number : 67 Question Id : 70819118370 Question Type : MCQ Option Shuffling : Yes

Is Question Mandatory : No

Correct Marks : 4 Wrong Marks : 1

ସମାକରଣ  $\int \frac{\sin\theta \cdot \sin 2\theta (\sin^6\theta + \sin^4\theta + \sin^2\theta) \sqrt{2\sin^4\theta + 3\sin^2\theta + 6}}{1 - \cos 2\theta} d\theta$  ର ମୂଲ୍ୟ ଅଟେ :

(c ସମାକରଣ ସ୍ଥିରାଙ୍କ)

Options :

70819160265.  $\frac{1}{18} [9 - 2\sin^6\theta - 3\sin^4\theta - 6\sin^2\theta]^{\frac{3}{2}} + c$

70819160266.

$$\frac{1}{18} \left[ 9 - 2\cos^6\theta - 3\cos^4\theta - 6\cos^2\theta \right]^{\frac{3}{2}} + c$$

70819160267.  $\frac{1}{18} \left[ 11 - 18\sin^2\theta + 9\sin^4\theta - 2\sin^6\theta \right]^{\frac{3}{2}} + c$

70819160268.  $\frac{1}{18} \left[ 11 - 18\cos^2\theta + 9\cos^4\theta - 2\cos^6\theta \right]^{\frac{3}{2}} + c$

**Question Number : 68 Question Id : 70819118371 Question Type : MCQ Option Shuffling : Yes**

**Is Question Mandatory : No**

**Correct Marks : 4 Wrong Marks : 1**

The value of  $\int_{-1}^1 x^2 e^{[x^3]} dx$ , where  $[t]$  denotes the greatest integer  $\leq t$ , is :

**Options :**

70819160269.  $\frac{e+1}{3}$

70819160270.  $\frac{1}{3e}$

70819160271.  $\frac{e-1}{3e}$

70819160272.  $\frac{e+1}{3e}$

**Question Number : 68 Question Id : 70819118371 Question Type : MCQ Option Shuffling : Yes**

**Is Question Mandatory : No**

**Correct Marks : 4 Wrong Marks : 1**

$\int_{-1}^1 x^2 e^{[x^3]} dx$ , ର ମୂଲ୍ୟ, ଯେଉଁଠି  $[t]$  ର ଅର୍ଥ,  $t$  ର ମୂଲ୍ୟ ଏକ ପୂର୍ଣ୍ଣ ସଂଖ୍ୟା  $\leq t$  (ଗ୍ରେଟେଷ୍ଟ ଇଣ୍ଟେଜର) ଅଟେ :

**Options :**

70819160269.  $\frac{e + 1}{3}$

70819160270.  $\frac{1}{3e}$

70819160271.  $\frac{e - 1}{3e}$

70819160272.  $\frac{e + 1}{3e}$

**Question Number : 69 Question Id : 70819118372 Question Type : MCQ Option Shuffling : Yes**

**Is Question Mandatory : No**

**Correct Marks : 4 Wrong Marks : 1**

If a curve passes through the origin and the slope of the tangent to it at any point  $(x, y)$  is

$\frac{x^2 - 4x + y + 8}{x - 2}$ , then this curve also passes through the point :

**Options :**

70819160273.  $(4, 5)$

70819160274.  $(5, 5)$

70819160275.  $(5, 4)$

70819160276.  $(4, 4)$

Question Number : 69 Question Id : 70819118372 Question Type : MCQ Option Shuffling : Yes

Is Question Mandatory : No

Correct Marks : 4 Wrong Marks : 1

ଯଦି ଗୋଟିଏ ବକ୍ରରେଖା ମୂଳବିନ୍ଦୁ ଦେଇ ଗତି କରେ ଏବଂ ବକ୍ରରେଖା ଉପରିସ୍ଥ ଯେକୌଣସି ବିନ୍ଦୁ  $(x, y)$  ଠାରେ ଅଙ୍କିତ

ସର୍ତ୍ତକର ସ୍ଳୋପ  $\frac{x^2 - 4x + y + 8}{x - 2}$  ଅଟେ, ତେବେ ଏହି ବକ୍ରରେଖା ମଧ୍ୟ ଗତି କରୁଥିବା ବିନ୍ଦୁଟି :

Options :

70819160273. (4, 5)

70819160274. (5, 5)

70819160275. (5, 4)

70819160276. (4, 4)

Question Number : 70 Question Id : 70819118373 Question Type : MCQ Option Shuffling : Yes

Is Question Mandatory : No

Correct Marks : 4 Wrong Marks : 1

The image of the point (3, 5) in the line  $x - y + 1 = 0$ , lies on :

Options :

70819160277.  $(x - 4)^2 + (y + 2)^2 = 16$

70819160278.  $(x - 2)^2 + (y - 4)^2 = 4$

70819160279.  $(x - 4)^2 + (y - 4)^2 = 8$

70819160280.  $(x - 2)^2 + (y - 2)^2 = 12$

Question Number : 70 Question Id : 70819118373 Question Type : MCQ Option Shuffling : Yes

Is Question Mandatory : No

Correct Marks : 4 Wrong Marks : 1

$x - y + 1 = 0$  ରେଖାରେ ବିନ୍ଦୁ  $(3, 5)$  ର ପ୍ରତିବିମ୍ବ ନିମ୍ନରେ ଥିବା କାହା ଉପରେ ଅବସ୍ଥିତ ହେବ :

Options :

70819160277.  $(x - 4)^2 + (y + 2)^2 = 16$

70819160278.  $(x - 2)^2 + (y - 4)^2 = 4$

70819160279.  $(x - 4)^2 + (y - 4)^2 = 8$

70819160280.  $(x - 2)^2 + (y - 2)^2 = 12$

Question Number : 71 Question Id : 70819118374 Question Type : MCQ Option Shuffling : Yes

Is Question Mandatory : No

Correct Marks : 4 Wrong Marks : 1

A tangent is drawn to the parabola  $y^2 = 6x$  which is perpendicular to the line  $2x + y = 1$ .  
Which of the following points does NOT lie on it ?

Options :

70819160281.  $(0, 3)$

70819160282.  $(-6, 0)$

70819160283.  $(5, 4)$

70819160284.  $(4, 5)$

Question Number : 71 Question Id : 70819118374 Question Type : MCQ Option Shuffling : Yes

Is Question Mandatory : No

Correct Marks : 4 Wrong Marks : 1

ପାରାବୋଲା  $y^2=6x$  ପ୍ରତି ଏକ ସ୍ପର୍ଶକ ଅଙ୍କିତ କରାଯାଇଛି, ଯାହା  $2x+y=1$  ରେଖା ପ୍ରତି ଲମ୍ବ । ନିମ୍ନଲିଖିତ କେଉଁ ବିନ୍ଦୁ ଏହା ଉପରେ ଅବସ୍ଥିତ ନୁହେଁ ?

**Options :**

70819160281. (0, 3)

70819160282. (-6, 0)

70819160283. (5, 4)

70819160284. (4, 5)

**Question Number : 72 Question Id : 70819118375 Question Type : MCQ Option Shuffling : Yes**

**Is Question Mandatory : No**

**Correct Marks : 4 Wrong Marks : 1**

If the curves,  $\frac{x^2}{a} + \frac{y^2}{b} = 1$  and  $\frac{x^2}{c} + \frac{y^2}{d} = 1$  intersect each other at an angle of  $90^\circ$ , then which of the following relations is TRUE ?

**Options :**

70819160285.  $a + b = c + d$

70819160286.  $a - b = c - d$

70819160287.  $ab = \frac{c + d}{a + b}$

70819160288.  $a - c = b + d$

**Question Number : 72 Question Id : 70819118375 Question Type : MCQ Option Shuffling : Yes**

**Is Question Mandatory : No**

Correct Marks : 4 Wrong Marks : 1

ଯଦି ବକ୍ରରେଖା ଦ୍ୱୟ  $\frac{x^2}{a} + \frac{y^2}{b} = 1$  ଓ  $\frac{x^2}{c} + \frac{y^2}{d} = 1$  ପରସ୍ପରକୁ  $90^\circ$  କୋଣରେ ଛେଦ କରନ୍ତି, ତେବେ ନିମ୍ନଲିଖିତ କେଉଁ ସମ୍ପର୍କଟି ସତ ?

Options :

70819160285.  $a + b = c + d$

70819160286.  $a - b = c - d$

70819160287.  $ab = \frac{c + d}{a + b}$

70819160288.  $a - c = b + d$

Question Number : 73 Question Id : 70819118376 Question Type : MCQ Option Shuffling : Yes

Is Question Mandatory : No

Correct Marks : 4 Wrong Marks : 1

Let  $\alpha$  be the angle between the lines whose direction cosines satisfy the equations  $l + m - n = 0$  and  $l^2 + m^2 - n^2 = 0$ . Then the value of  $\sin^4 \alpha + \cos^4 \alpha$  is :

Options :

70819160289.  $\frac{5}{8}$

70819160290.  $\frac{3}{8}$

70819160291.  $\frac{1}{2}$

70819160292.  $\frac{3}{4}$

Question Number : 73 Question Id : 70819118376 Question Type : MCQ Option Shuffling : Yes

Is Question Mandatory : No

Correct Marks : 4 Wrong Marks : 1

ମନେକର ରେଖା ଦୁଇ ଯାହାର ଦିଶାୟ କୋଣ୍ୟା (d.c.s.), ସମୀକରଣ  $l+m-n=0$  ଓ  $l^2+m^2-n^2=0$  କୁ ସିଦ୍ଧ କରେ ଓ ସେମାନଙ୍କର ଅନ୍ତର୍ଗତ କୋଣ  $\alpha$  । ତେବେ  $\sin^4\alpha + \cos^4\alpha$  ର ମୂଲ୍ୟ ଅଟେ :

Options :

70819160289.  $\frac{5}{8}$

70819160290.  $\frac{3}{8}$

70819160291.  $\frac{1}{2}$

70819160292.  $\frac{3}{4}$

Question Number : 74 Question Id : 70819118377 Question Type : MCQ Option Shuffling : Yes

Is Question Mandatory : No

Correct Marks : 4 Wrong Marks : 1

The equation of the line through the point  $(0, 1, 2)$  and perpendicular to the line

$$\frac{x-1}{2} = \frac{y+1}{3} = \frac{z-1}{-2} \text{ is:}$$

Options :

70819160293.  $\frac{x}{3} = \frac{y-1}{4} = \frac{z-2}{-3}$

70819160294.  $\frac{x}{-3} = \frac{y-1}{4} = \frac{z-2}{3}$

70819160295.  $\frac{x}{3} = \frac{y-1}{-4} = \frac{z-2}{3}$

70819160296.  $\frac{x}{3} = \frac{y-1}{4} = \frac{z-2}{3}$

**Question Number : 74 Question Id : 70819118377 Question Type : MCQ Option Shuffling : Yes**  
**Is Question Mandatory : No**

**Correct Marks : 4 Wrong Marks : 1**

ବିନ୍ଦୁ  $(0, 1, 2)$  ମଧ୍ୟ ଦେଇ ଗତି କରୁଥିବା ଏବଂ  $\frac{x-1}{2} = \frac{y+1}{3} = \frac{z-1}{-2}$  ରେଖା ପ୍ରତି ଲମ୍ବ ଥିବା ରେଖାଟିର ସମୀକରଣଟି ଅଟେ :

**Options :**

70819160293.  $\frac{x}{3} = \frac{y-1}{4} = \frac{z-2}{-3}$

70819160294.  $\frac{x}{-3} = \frac{y-1}{4} = \frac{z-2}{3}$

70819160295.  $\frac{x}{3} = \frac{y-1}{-4} = \frac{z-2}{3}$

70819160296.  $\frac{x}{3} = \frac{y-1}{4} = \frac{z-2}{3}$

**Question Number : 75 Question Id : 70819118378 Question Type : MCQ Option Shuffling : Yes**  
**Is Question Mandatory : No**

**Correct Marks : 4 Wrong Marks : 1**

When a missile is fired from a ship, the probability that it is intercepted is  $\frac{1}{3}$  and the probability that the missile hits the target, given that it is not intercepted, is  $\frac{3}{4}$ . If three missiles are fired independently from the ship, then the probability that all three hit the target, is :

**Options :**

70819160297.  $\frac{1}{27}$

70819160298.  $\frac{1}{8}$

70819160299.  $\frac{3}{8}$

70819160300.  $\frac{3}{4}$

Question Number : 75 Question Id : 70819118378 Question Type : MCQ Option Shuffling : Yes

Is Question Mandatory : No

Correct Marks : 4 Wrong Marks : 1

ଯେତେବେଳେ ଏକ ଜାହାଜରୁ ଏକ କ୍ଷେପଣାସ୍ତ୍ରକୁ ନିକ୍ଷେପ (ଉତ୍ତ୍ରେପ) କରାଯାଏ, ଏହାକୁ ନିଶ୍ଚିତ କରିଦେବାର ସମ୍ଭାବ୍ୟତା  $\frac{1}{3}$

ଅଟେ ଏବଂ ଏହି କ୍ଷେପଣାସ୍ତ୍ର ଲକ୍ଷ୍ୟଭେଦ କରିବାର ସମ୍ଭାବ୍ୟତା  $\frac{3}{4}$  (ଯେତେବେଳେ ନିଶ୍ଚିତ ନହୁଏ) ଅଟେ । ଯଦି ତିନିଗୋଟି

କ୍ଷେପଣାସ୍ତ୍ରକୁ ପୃଥକ୍ (ସ୍ୱାଧୀନ) ଭାବରେ ଜାହାଜରୁ ନିକ୍ଷେପ କରାହୁଏ, ତେବେ ସମସ୍ତ ତିନିଗୋଟି କ୍ଷେପଣାସ୍ତ୍ର ଲକ୍ଷ୍ୟଭେଦ କରିବାର ସମ୍ଭାବ୍ୟତା ଅଟେ :

Options :

70819160297.  $\frac{1}{27}$

70819160298.  $\frac{1}{8}$

70819160299.  $\frac{3}{8}$

70819160300.  $\frac{3}{4}$

Question Number : 76 Question Id : 70819118379 Question Type : MCQ Option Shuffling : Yes

Is Question Mandatory : No

Correct Marks : 4 Wrong Marks : 1

The coefficients  $a$ ,  $b$  and  $c$  of the quadratic equation,  $ax^2 + bx + c = 0$  are obtained by throwing a dice three times. The probability that this equation has equal roots is :

Options :

70819160301.  $\frac{1}{36}$

70819160302.  $\frac{1}{54}$

70819160303.  $\frac{1}{72}$

70819160304.  $\frac{5}{216}$

Question Number : 76 Question Id : 70819118379 Question Type : MCQ Option Shuffling : Yes

Is Question Mandatory : No

Correct Marks : 4 Wrong Marks : 1

ଏକ ପକ୍ଷାକାଠିକୁ 3 ଥର ଫୋପାଡ଼ିବା ଦ୍ୱାରା ଦ୍ୱିଘାତ ସମୀକରଣ  $ax^2 + bx + c = 0$  ର ସହଗ ଗୁଡ଼ିକ  $a$ ,  $b$  ଓ  $c$  ମିଳିଥାଏ ।  
ଏହି ସମୀକରଣର ବାଜ (ମୂଳ) ଦୁଇ ସମାନ ହେବାର ସମ୍ଭାବ୍ୟତା ଅଟେ :

Options :

70819160301.  $\frac{1}{36}$

70819160302.  $\frac{1}{54}$

70819160303.  $\frac{1}{72}$

70819160304.  $\frac{5}{216}$

**Question Number : 77 Question Id : 70819118380 Question Type : MCQ Option Shuffling : Yes Is Question Mandatory : No**

**Correct Marks : 4 Wrong Marks : 1**

All possible values of  $\theta \in [0, 2\pi]$  for which  $\sin 2\theta + \tan 2\theta > 0$  lie in :

**Options :**

70819160305.  $\left(0, \frac{\pi}{2}\right) \cup \left(\pi, \frac{3\pi}{2}\right)$

70819160306.  $\left(0, \frac{\pi}{4}\right) \cup \left(\frac{\pi}{2}, \frac{3\pi}{4}\right) \cup \left(\frac{3\pi}{2}, \frac{11\pi}{6}\right)$

70819160307.  $\left(0, \frac{\pi}{2}\right) \cup \left(\frac{\pi}{2}, \frac{3\pi}{4}\right) \cup \left(\pi, \frac{7\pi}{6}\right)$

70819160308.  $\left(0, \frac{\pi}{4}\right) \cup \left(\frac{\pi}{2}, \frac{3\pi}{4}\right) \cup \left(\pi, \frac{5\pi}{4}\right) \cup \left(\frac{3\pi}{2}, \frac{7\pi}{4}\right)$

**Question Number : 77 Question Id : 70819118380 Question Type : MCQ Option Shuffling : Yes Is Question Mandatory : No**

**Correct Marks : 4 Wrong Marks : 1**

$[0, 2\pi]$  ଅନ୍ତରାଳରେ  $\theta$  ର ସମସ୍ତ ସମ୍ଭବ ମୂଲ୍ୟ ପାଇଁ ଯଦି  $\sin 2\theta + \tan 2\theta > 0$  ହୁଏ ତେବେ  $\theta$  ରହିବା ଅନ୍ତରାଳ :

**Options :**

70819160305.  $\left(0, \frac{\pi}{2}\right) \cup \left(\pi, \frac{3\pi}{2}\right)$

70819160306.

$$\left(0, \frac{\pi}{4}\right) \cup \left(\frac{\pi}{2}, \frac{3\pi}{4}\right) \cup \left(\frac{3\pi}{2}, \frac{11\pi}{6}\right)$$

70819160307.  $\left(0, \frac{\pi}{2}\right) \cup \left(\frac{\pi}{2}, \frac{3\pi}{4}\right) \cup \left(\pi, \frac{7\pi}{6}\right)$

70819160308.  $\left(0, \frac{\pi}{4}\right) \cup \left(\frac{\pi}{2}, \frac{3\pi}{4}\right) \cup \left(\pi, \frac{5\pi}{4}\right) \cup \left(\frac{3\pi}{2}, \frac{7\pi}{4}\right)$

Question Number : 78 Question Id : 70819118381 Question Type : MCQ Option Shuffling : Yes

Is Question Mandatory : No

Correct Marks : 4 Wrong Marks : 1

The total number of positive integral solutions  $(x, y, z)$  such that  $xyz = 24$  is :

Options :

70819160309. 24

70819160310. 30

70819160311. 36

70819160312. 45

Question Number : 78 Question Id : 70819118381 Question Type : MCQ Option Shuffling : Yes

Is Question Mandatory : No

Correct Marks : 4 Wrong Marks : 1

$(x, y, z)$  ପାଇଁ ଧନାତ୍ମକ ପୂର୍ଣ୍ଣସଂଖ୍ୟା ମୂଲ୍ୟ ଥିବ, ଯେପରିକି  $xyz = 24$  ର ମୋଟ ସମାଧାନ ସଂଖ୍ୟା ଅଟେ :

Options :

70819160309. 24

70819160310. 30

70819160311. 36

70819160312. 45

**Question Number : 79 Question Id : 70819118382 Question Type : MCQ Option Shuffling : Yes**

**Is Question Mandatory : No**

**Correct Marks : 4 Wrong Marks : 1**

A man is observing, from the top of a tower, a boat speeding towards the tower from a certain point A, with uniform speed. At that point, angle of depression of the boat with the man's eye is  $30^\circ$  (Ignore man's height). After sailing for 20 seconds, towards the base of the tower (which is at the level of water), the boat has reached a point B, where the angle of depression is  $45^\circ$ . Then the time taken (in seconds) by the boat from B to reach the base of the tower is :

**Options :**

70819160313. 10

70819160314.  $10(\sqrt{3} + 1)$

70819160315.  $10\sqrt{3}$

70819160316.  $10(\sqrt{3} - 1)$

**Question Number : 79 Question Id : 70819118382 Question Type : MCQ Option Shuffling : Yes**

**Is Question Mandatory : No**

**Correct Marks : 4 Wrong Marks : 1**

ଏକ ଗମ୍ଭୀର ଉପରୁ ଜଣେ ଲୋକ ଦେଖୁଛି ଯେ ଗୋଟିଏ ନୌକା ଏକ ନିର୍ଦ୍ଦିଷ୍ଟ ବିନ୍ଦୁ A ଠାରୁ ଗମ୍ଭୀର ଆଡ଼କୁ ସମାନ ବେଗରେ ଆସୁଅଛି । ସେହି ବିନ୍ଦୁରେ ଲୋକଟିର ଆଖି ସହ ନୌକାଟିର ଅବନତ କୋଣଟି  $30^\circ$  । (ଲୋକଟିର ଉଚ୍ଚତାକୁ ବିଚାରକୁ ନ ନିଆଯାଉ) । 20 ସେକେଣ୍ଡ ନୌକାଟି ଗମ୍ଭୀର ପାଦ ଦେଶକୁ ଆସିବା ପରେ (ଗମ୍ଭୀର ଭୂମି ଜଳ ସହ ସମସ୍ତର) ନୌକାଟି B ବିନ୍ଦୁରେ ପହଞ୍ଚିଲା, ଯେଉଁଠାରେ ଅବନତ କୋଣର ମାପ  $45^\circ$  ଅଟେ । ବିନ୍ଦୁ B ଠାରୁ ଗମ୍ଭୀର ପାଦଦେଶରେ ନୌକାଟି ପହଞ୍ଚିବାର ସମୟ (ସେକେଣ୍ଡରେ) ଅଟେ :

Options :

70819160313.  $10$

70819160314.  $10(\sqrt{3} + 1)$

70819160315.  $10\sqrt{3}$

70819160316.  $10(\sqrt{3} - 1)$

Question Number : 80 Question Id : 70819118383 Question Type : MCQ Option Shuffling : Yes

Is Question Mandatory : No

Correct Marks : 4 Wrong Marks : 1

The statement  $A \rightarrow (B \rightarrow A)$  is equivalent to :

Options :

70819160317.  $A \rightarrow (A \rightarrow B)$

70819160318.  $A \rightarrow (A \vee B)$

70819160319.  $A \rightarrow (A \wedge B)$

70819160320.  $A \rightarrow (A \leftrightarrow B)$

Question Number : 80 Question Id : 70819118383 Question Type : MCQ Option Shuffling : Yes

Is Question Mandatory : No

Correct Marks : 4 Wrong Marks : 1

ଉକ୍ତି  $A \rightarrow (B \rightarrow A)$  ଚିର ସମତୁଲ୍ୟ ଅଟେ :

Options :

70819160317.  $A \rightarrow (A \rightarrow B)$

70819160318.  $A \rightarrow (A \vee B)$

70819160319.  $A \rightarrow (A \wedge B)$

70819160320.  $A \rightarrow (A \leftrightarrow B)$

## Mathematics Section B

Section Id :	708191765
Section Number :	6
Section type :	Online
Mandatory or Optional :	Mandatory
Number of Questions :	10
Number of Questions to be attempted :	5
Section Marks :	20
Mark As Answered Required? :	Yes
Sub-Section Number :	1
Sub-Section Id :	7081911045
Question Shuffling Allowed :	Yes

Question Number : 81 Question Id : 70819118384 Question Type : SA

Correct Marks : 4 Wrong Marks : 0

If  $A = \begin{bmatrix} 0 & -\tan\left(\frac{\theta}{2}\right) \\ \tan\left(\frac{\theta}{2}\right) & 0 \end{bmatrix}$  and  $(I_2 + A)(I_2 - A)^{-1} = \begin{bmatrix} a & -b \\ b & a \end{bmatrix}$ , then  $13(a^2 + b^2)$  is equal to

Response Type : Numeric

Evaluation Required For SA : Yes

Show Word Count : Yes

Answers Type : Range

Text Areas : PlainText

Possible Answers :

5 to 5.001

Question Number : 81 Question Id : 70819118384 Question Type : SA

Correct Marks : 4 Wrong Marks : 0

ଉତ୍ତର  $A = \begin{bmatrix} 0 & -\tan\left(\frac{\theta}{2}\right) \\ \tan\left(\frac{\theta}{2}\right) & 0 \end{bmatrix}$  ଶୁଦ୍ଧ  $(I_2 + A) (I_2 - A)^{-1} = \begin{bmatrix} a & -b \\ b & a \end{bmatrix}$  ଖାଲି  $13(a^2 + b^2)$

ଉତ୍ତର \_\_\_\_\_

Response Type : Numeric

Evaluation Required For SA : Yes

Show Word Count : Yes

Answers Type : Range

Text Areas : PlainText

Possible Answers :

5 to 5.001

Question Number : 82 Question Id : 70819118385 Question Type : SA

Correct Marks : 4 Wrong Marks : 0

Let  $A = \begin{bmatrix} x & y & z \\ y & z & x \\ z & x & y \end{bmatrix}$ , where  $x, y$  and  $z$  are real numbers such that  $x + y + z > 0$  and  $xyz = 2$ .

If  $A^2 = I_3$ , then the value of  $x^3 + y^3 + z^3$  is \_\_\_\_\_.

Response Type : Numeric

Evaluation Required For SA : Yes

Show Word Count : Yes

Answers Type : Range

Text Areas : PlainText

Possible Answers :

5 to 5.001

Question Number : 82 Question Id : 70819118385 Question Type : SA

Correct Marks : 4 Wrong Marks : 0

ମନେକର  $A = \begin{bmatrix} x & y & z \\ y & z & x \\ z & x & y \end{bmatrix}$ , ଯେଉଁଠାରେ  $x, y$  ଓ  $z$  ବାସ୍ତବ ସଂଖ୍ୟା ଯେପରିକି  $x+y+z > 0$  ଓ  $xyz=2$  । ଯଦି

$A^2=I_3$ , ତେବେ  $x^3+y^3+z^3$  ର ମୂଲ୍ୟ ଅଟେ \_\_\_\_\_ ।

Response Type : Numeric

Evaluation Required For SA : Yes

Show Word Count : Yes

Answers Type : Range

Text Areas : PlainText

Possible Answers :

5 to 5.001

Question Number : 83 Question Id : 70819118386 Question Type : SA

Correct Marks : 4 Wrong Marks : 0

If the system of equations

$$kx + y + 2z = 1$$

$$3x - y - 2z = 2$$

$$-2x - 2y - 4z = 3$$

has infinitely many solutions, then  $k$  is equal to \_\_\_\_\_.

Response Type : Numeric

Evaluation Required For SA : Yes

Show Word Count : Yes

Answers Type : Range

Text Areas : PlainText

Possible Answers :

**Question Number : 83 Question Id : 70819118386 Question Type : SA**

**Correct Marks : 4 Wrong Marks : 0**

ଯଦି ସମୀକରଣ

$$kx + y + 2z = 1$$

$$3x - y - 2z = 2$$

$$-2x - 2y - 4z = 3$$

ସମୂହର ଅସୀମ ସମାଧାନ ଅଛି, ତେବେ k ସମାନ \_\_\_\_\_।

**Response Type : Numeric**

**Evaluation Required For SA : Yes**

**Show Word Count : Yes**

**Answers Type : Range**

**Text Areas : PlainText**

**Possible Answers :**

5 to 5.001

**Question Number : 84 Question Id : 70819118387 Question Type : SA**

**Correct Marks : 4 Wrong Marks : 0**

The total number of numbers, lying between 100 and 1000 that can be formed with the digits 1, 2, 3, 4, 5, if the repetition of digits is not allowed and numbers are divisible by either 3 or 5, is \_\_\_\_\_.

**Response Type : Numeric**

**Evaluation Required For SA : Yes**

**Show Word Count : Yes**

**Answers Type : Range**

**Text Areas : PlainText**

**Possible Answers :**

5 to 5.001

**Question Number : 84 Question Id : 70819118387 Question Type : SA**

**Correct Marks : 4 Wrong Marks : 0**

1, 2, 3, 4, 5 ଅଙ୍କଗୁଡ଼ିକୁ ବ୍ୟବହାର କରି, ଯଦି କୌଣସି ଅଙ୍କକୁ ଦ୍ୱିତୀୟ ଥର ବ୍ୟବହାର କରା ନଯାଏ ଓ ସଂଖ୍ୟାଗୁଡ଼ିକ 3 କିମ୍ବା 5 ଦ୍ୱାରା ବିଭାଜ୍ୟ ହେଉଥାଏ ତେବେ 100 ଏବଂ 1000 ମଧ୍ୟରେ ତିଆରି କରାଯାଇପାରୁଥିବା ସଂଖ୍ୟା ମାନଙ୍କର ମୋଟ ସଂଖ୍ୟା ଅଟେ \_\_\_\_\_।

**Response Type :** Numeric

**Evaluation Required For SA :** Yes

**Show Word Count :** Yes

**Answers Type :** Range

**Text Areas :** PlainText

**Possible Answers :**

5 to 5.001

**Question Number : 85 Question Id : 70819118388 Question Type : SA**

**Correct Marks : 4 Wrong Marks : 0**

Let  $A_1, A_2, A_3, \dots$  be squares such that for each  $n \geq 1$ , the length of the side of  $A_n$  equals the length of diagonal of  $A_{n+1}$ . If the length of  $A_1$  is 12 cm, then the smallest value of  $n$  for which area of  $A_n$  is less than one, is \_\_\_\_\_.

**Response Type :** Numeric

**Evaluation Required For SA :** Yes

**Show Word Count :** Yes

**Answers Type :** Range

**Text Areas :** PlainText

**Possible Answers :**

5 to 5.001

**Question Number : 85 Question Id : 70819118388 Question Type : SA**

**Correct Marks : 4 Wrong Marks : 0**

ମନେକର  $A_1, A_2, A_3, \dots$  କେତେଗୋଟି ବର୍ଗକ୍ଷେତ୍ର ଯେପରିକି ପ୍ରତ୍ୟେକ  $n(n \geq 1)$  ପାଇଁ,  $A_n$  ର ଏକ ପାର୍ଶ୍ୱର ଲମ୍ବ (ଦୈର୍ଘ୍ୟ)  $A_{n+1}$  ର କର୍ଣ୍ଣର ଦୈର୍ଘ୍ୟ ସହ ସମାନ । ଯଦି  $A_1$  ର ଏକ ପାର୍ଶ୍ୱର ଲମ୍ବ (ଦୈର୍ଘ୍ୟ) 12 ସେମି ଅଟେ, ତେବେ  $A_n$  ର କ୍ଷେତ୍ରଫଳ 1 ଠାରୁ ସାନ ହେବା ପାଇଁ  $n$  ର ସର୍ବନିମ୍ନ ମୂଲ୍ୟ ଅଟେ \_\_\_\_\_।

**Response Type :** Numeric

**Evaluation Required For SA :** Yes

Show Word Count : Yes

Answers Type : Range

Text Areas : PlainText

Possible Answers :

5 to 5.001

Question Number : 86 Question Id : 70819118389 Question Type : SA

Correct Marks : 4 Wrong Marks : 0

The number of points, at which the function  $f(x) = |2x+1| - 3|x+2| + |x^2+x-2|$ ,  $x \in \mathbb{R}$  is not differentiable, is \_\_\_\_\_.

Response Type : Numeric

Evaluation Required For SA : Yes

Show Word Count : Yes

Answers Type : Range

Text Areas : PlainText

Possible Answers :

5 to 5.001

Question Number : 86 Question Id : 70819118389 Question Type : SA

Correct Marks : 4 Wrong Marks : 0

ଫଳନ  $f(x) = |2x+1| - 3|x+2| + |x^2+x-2|$ , ( $x \in \mathbb{R}$ ) ଚି ଅବକଳନୀୟ ହୋଇପାରୁନଥିବା ବିନ୍ଦୁମାନଙ୍କ ସଂଖ୍ୟା ଅଟେ \_\_\_\_\_।

Response Type : Numeric

Evaluation Required For SA : Yes

Show Word Count : Yes

Answers Type : Range

Text Areas : PlainText

Possible Answers :

5 to 5.001

Question Number : 87 Question Id : 70819118390 Question Type : SA

Correct Marks : 4 Wrong Marks : 0

Let  $f(x)$  be a polynomial of degree 6 in  $x$ , in which the coefficient of  $x^6$  is unity and it has extrema at  $x = -1$  and  $x = 1$ . If  $\lim_{x \rightarrow 0} \frac{f(x)}{x^3} = 1$ , then  $5 \cdot f(2)$  is equal to \_\_\_\_\_.

Response Type : Numeric

Evaluation Required For SA : Yes

Show Word Count : Yes

Answers Type : Range

Text Areas : PlainText

Possible Answers :

5 to 5.001

Question Number : 87 Question Id : 70819118390 Question Type : SA

Correct Marks : 4 Wrong Marks : 0

ମନେକର  $f(x)$ ,  $x$  ର 6 ଘାତ ବିଶିଷ୍ଟ ଏକ ପଲିନୋମିଆଲ୍ (ବହୁରାଶୀୟ), ଯେଉଁଠାରେ  $x^6$  ର ସହଗ 1 ଅଟେ ଏବଂ ଏହାର ସର୍ବାଧିକ ବା ସର୍ବନିମ୍ନ (ଅନ୍ତତମ) ମୂଲ୍ୟ  $x = -1$  ଏବଂ  $x = 1$  ଠାରେ ଅଛି । ଯଦି  $\lim_{x \rightarrow 0} \frac{f(x)}{x^3} = 1$ , ତେବେ  $5 \cdot f(2)$  ସମାନ \_\_\_\_\_ ।

Response Type : Numeric

Evaluation Required For SA : Yes

Show Word Count : Yes

Answers Type : Range

Text Areas : PlainText

Possible Answers :

5 to 5.001

Question Number : 88 Question Id : 70819118391 Question Type : SA

Correct Marks : 4 Wrong Marks : 0

The graphs of sine and cosine functions, intersect each other at a number of points and between two consecutive points of intersection, the two graphs enclose the same area  $A$ . Then  $A^4$  is equal to \_\_\_\_\_.

**Response Type :** Numeric

**Evaluation Required For SA :** Yes

**Show Word Count :** Yes

**Answers Type :** Range

**Text Areas :** PlainText

**Possible Answers :**

5 to 5.001

**Question Number : 88 Question Id : 70819118391 Question Type : SA**

**Correct Marks : 4 Wrong Marks : 0**

sine ଓ cosine ଫଳନର ଲେଖାଚିତ୍ର ପରସ୍ପରକୁ ଅନେକ ବିନ୍ଦୁରେ ଛେଦ କରନ୍ତି ଏବଂ ଦୁଇଟି ପାଖାପାଖି ଛେଦ ବିନ୍ଦୁ ମଧ୍ୟରେ ଲେଖାଚିତ୍ର ଦୁଇ ସମାନ କ୍ଷେତ୍ରଫଳ ବିଶିଷ୍ଟ କ୍ଷେତ୍ର 'A' ଆବଦ୍ଧ କରନ୍ତି । ତେବେ  $A^4$  ର ମୂଲ୍ୟ \_\_\_\_\_ ।

**Response Type :** Numeric

**Evaluation Required For SA :** Yes

**Show Word Count :** Yes

**Answers Type :** Range

**Text Areas :** PlainText

**Possible Answers :**

5 to 5.001

**Question Number : 89 Question Id : 70819118392 Question Type : SA**

**Correct Marks : 4 Wrong Marks : 0**

The locus of the point of intersection of the lines  $(\sqrt{3})kx + ky - 4\sqrt{3} = 0$  and  $\sqrt{3}x - y - 4(\sqrt{3})k = 0$  is a conic, whose eccentricity is \_\_\_\_\_.

**Response Type :** Numeric

**Evaluation Required For SA :** Yes

**Show Word Count :** Yes

**Answers Type :** Range

**Text Areas :** PlainText

**Possible Answers :**

Question Number : 89 Question Id : 70819118392 Question Type : SA

Correct Marks : 4 Wrong Marks : 0

$(\sqrt{3})kx + ky - 4\sqrt{3} = 0$  ଓ  $\sqrt{3}x - y - 4(\sqrt{3})k = 0$  ରେଖା ଦ୍ଵୟର ଛେଦବିନ୍ଦୁମାନଙ୍କର ସଂଚାର ପଥ (ଲୋକସ) ଏକ ଶଙ୍କୁ (କୋନିକ୍), ଯାହାର ଉକ୍ଳେନ୍ଦ୍ରକ (ଏସେଣ୍ଟସିଭିଟି) ଅଟେ \_\_\_\_\_।

Response Type : Numeric

Evaluation Required For SA : Yes

Show Word Count : Yes

Answers Type : Range

Text Areas : PlainText

Possible Answers :

5 to 5.001

Question Number : 90 Question Id : 70819118393 Question Type : SA

Correct Marks : 4 Wrong Marks : 0

Let  $\vec{a} = \hat{i} + 2\hat{j} - \hat{k}$ ,  $\vec{b} = \hat{i} - \hat{j}$  and  $\vec{c} = \hat{i} - \hat{j} - \hat{k}$  be three given vectors. If  $\vec{r}$  is a vector such that  $\vec{r} \times \vec{a} = \vec{c} \times \vec{a}$  and  $\vec{r} \cdot \vec{b} = 0$ , then  $\vec{r} \cdot \vec{a}$  is equal to \_\_\_\_\_.

Response Type : Numeric

Evaluation Required For SA : Yes

Show Word Count : Yes

Answers Type : Range

Text Areas : PlainText

Possible Answers :

5 to 5.001

Question Number : 90 Question Id : 70819118393 Question Type : SA

Correct Marks : 4 Wrong Marks : 0

ମନେକର  $\vec{a} = \hat{i} + 2\hat{j} - \hat{k}$ ,  $\vec{b} = \hat{i} - \hat{j}$  ଏବଂ  $\vec{c} = \hat{i} - \hat{j} - \hat{k}$  ତିନିଗୋଟି ଦତ୍ତ ସଦିଶ ରାଶି । ସଦିଶ  $\vec{r}$

ଗୋଟିଏ ସଦିଶ ରାଶି ଯେପରିକି  $\vec{r} \times \vec{a} = \vec{c} \times \vec{a}$  ଏବଂ  $\vec{r} \cdot \vec{b} = 0$ , ତେବେ  $\vec{r} \cdot \vec{a}$  ସମାନ \_\_\_\_\_ ।

**Response Type :** Numeric

**Evaluation Required For SA :** Yes

**Show Word Count :** Yes

**Answers Type :** Range

**Text Areas :** PlainText

**Possible Answers :**

5 to 5.001

