

<b>Question Paper Name :</b>	B TECH EO 25th Feb 2021 Shift 2
<b>Subject Name :</b>	B TECH EO
<b>Creation Date :</b>	2021-02-24 19:07:07
<b>Duration :</b>	180
<b>Number of Questions :</b>	90
<b>Total Marks :</b>	300
<b>Display Marks:</b>	Yes

## B TECH EO

<b>Group Number :</b>	1
<b>Group Id :</b>	708191210
<b>Group Maximum Duration :</b>	0
<b>Group Minimum Duration :</b>	180
<b>Show Attended Group? :</b>	No
<b>Edit Attended Group? :</b>	No
<b>Break time :</b>	0
<b>Group Marks :</b>	300
<b>Is this Group for Examiner? :</b>	No

## Physics Section A

<b>Section Id :</b>	708191838
<b>Section Number :</b>	1
<b>Section type :</b>	Online

<b>Mandatory or Optional :</b>	Mandatory
<b>Number of Questions :</b>	20
<b>Number of Questions to be attempted :</b>	20
<b>Section Marks :</b>	80
<b>Mark As Answered Required? :</b>	Yes
<b>Sub-Section Number :</b>	1
<b>Sub-Section Id :</b>	7081911118
<b>Question Shuffling Allowed :</b>	Yes

**Question Number : 1 Question Id : 70819119474 Question Type : MCQ Option Shuffling : Yes Is**

**Question Mandatory : No**

**Correct Marks : 4 Wrong Marks : 1**

If  $e$  is the electronic charge,  $c$  is the speed of light in free space and  $h$  is Planck's constant, the

quantity  $\frac{1}{4\pi\epsilon_0} \frac{|e|^2}{\hbar c}$  has dimensions of :

**Options :**

70819163571.  $[M L T^0]$

70819163572.  $[M L T^{-1}]$

70819163573.  $[M^0 L^0 T^0]$

70819163574.  $[L C^{-1}]$

**Question Number : 1 Question Id : 70819119474 Question Type : MCQ Option Shuffling : Yes Is**

**Question Mandatory : No**

**Correct Marks : 4 Wrong Marks : 1**

ଯଦି 'e' ଇଲେକଟ୍ରୋନିକ୍ ଚାର୍ଜ, 'c' ମୁକ୍ତ ସ୍ଥାନରେ ଆଲୋକର ବେଗ ଏବଂ 'h' ପ୍ଲାଙ୍କ୍‌ଙ୍କ ସ୍ଥିରାଙ୍କ ଅଟେ । ଭୌତିକ ରାଶି

$\frac{1}{4\pi\epsilon_0} \frac{|e|^2}{\hbar c}$  ର ବିମିତ ହେଉଛି :

Options :

70819163571.  $[M L T^0]$

70819163572.  $[M L T^{-1}]$

70819163573.  $[M^0 L^0 T^0]$

70819163574.  $[L C^{-1}]$

Question Number : 2 Question Id : 70819119475 Question Type : MCQ Option Shuffling : Yes Is Question Mandatory : No

Correct Marks : 4 Wrong Marks : 1

A stone is dropped from the top of a building. When it crosses a point 5 m below the top, another stone starts to fall from a point 25 m below the top. Both stones reach the bottom of building simultaneously. The height of the building is :

Options :

70819163575. 45 m

70819163576. 25 m

70819163577. 35 m

70819163578. 50 m

Question Number : 2 Question Id : 70819119475 Question Type : MCQ Option Shuffling : Yes Is Question Mandatory : No

Correct Marks : 4 Wrong Marks : 1

ଗୋଟିଏ କୋଠା ଶୀର୍ଷରୁ ଏକ ପଥର ଖଣ୍ଡକୁ ପକାଯାଉଛି । ଏହା ଶୀର୍ଷରୁ 5 m ତଳେ ଥିବା ଏକ ବିନ୍ଦୁକୁ ଅତିକ୍ରମ କଲା ସମୟରେ ଆଉ ଏକ ପଥର ଖଣ୍ଡକୁ ଶୀର୍ଷରୁ 25 m ତଳେ ଥିବା ଏକ ବିନ୍ଦୁରୁ ପକାଗଲା । ଉଭୟ ପଥର ଖଣ୍ଡ ଦୁଇଟି କୋଠାର ପାଦଦେଶରେ ଏକା ସମୟରେ ପହଞ୍ଚୁଛନ୍ତି । କୋଠାଟିର ଉଚ୍ଚତା ଅଟେ \_\_\_\_\_ ।

Options :

70819163575. 45 m

70819163576. 25 m

70819163577. 35 m

70819163578. 50 m

Question Number : 3 Question Id : 70819119476 Question Type : MCQ Option Shuffling : Yes Is Question Mandatory : No

Correct Marks : 4 Wrong Marks : 1

A sphere of radius 'a' and mass 'm' rolls along a horizontal plane with constant speed  $v_0$ . It encounters an inclined plane at angle  $\theta$  and climbs upward. Assuming that it rolls without slipping, how far up the sphere will travel ?

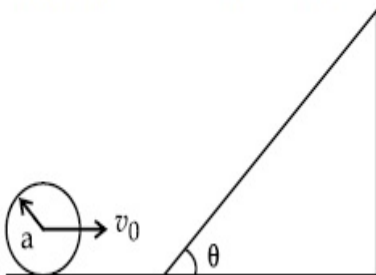

Options :

70819163579.  $\frac{v_0^2}{2g \sin\theta}$

70819163580.  $\frac{v_0^2}{5g \sin\theta}$

70819163581.  $\frac{10v_0^2}{7g \sin\theta}$

70819163582.  $\frac{2}{5} \frac{v_0^2}{g \sin\theta}$

Question Number : 3 Question Id : 70819119476 Question Type : MCQ Option Shuffling : Yes Is

Question Mandatory : No

Correct Marks : 4 Wrong Marks : 1

ଏକ ଭୂସମାନ୍ତର ପୃଷ୍ଠରେ 'a' ବ୍ୟାସାର୍ଦ୍ଧ ଓ 'm' ବସ୍ତୁତ୍ତ୍ୱ ବିଶିଷ୍ଟ ଏକ ଗୋଲକ ଛିର ସଳଖ ବେଗ  $v_0$  ରେ ଗଡ଼ି ଗଡ଼ି ଯାଉଛି । ଏହା ' $\theta$ ' କୋଣରେ ଆନତ ଥିବା ଏକ ତାଲୁଆ ସମତଳକୁ ଭେଟୁଛି ଏବଂ ଉପର ଆଡ଼କୁ ଗଡ଼ି ଗଡ଼ି ଯାଉଛି । ଧରାଯାଉ ଏହା ବିନା ଖସଡ଼ାରେ ଗଡ଼ି ଗଡ଼ି ଯାଏ । ଗୋଲକଟି ଉପରକୁ କେତେ ବାଟ ଗତି କରିବ ?

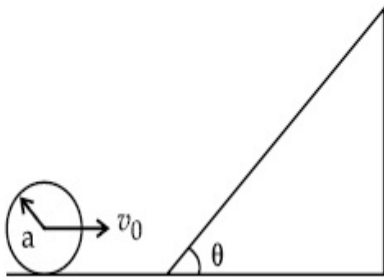

Options :

70819163579.  $\frac{v_0^2}{2g \sin\theta}$

70819163580.  $\frac{v_0^2}{5g \sin\theta}$

70819163581.  $\frac{10v_0^2}{7g \sin\theta}$

70819163582.  $\frac{2}{5} \frac{v_0^2}{g \sin\theta}$

Question Number : 4 Question Id : 70819119477 Question Type : MCQ Option Shuffling : Yes Is

Question Mandatory : No

Correct Marks : 4 Wrong Marks : 1

The point A moves with a uniform speed along the circumference of a circle of radius 0.36 m and covers  $30^\circ$  in 0.1 s. The perpendicular projection 'P' from 'A' on the diameter MN represents the simple harmonic motion of 'P'. The restoration force per unit mass when P touches M will be :

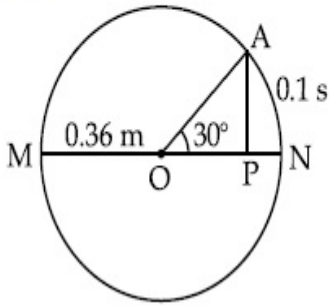

Options :

70819163583. 100 N

70819163584. 9.87 N

70819163585. 50 N

70819163586. 0.49 N

Question Number : 4 Question Id : 70819119477 Question Type : MCQ Option Shuffling : Yes Is

Question Mandatory : No

Correct Marks : 4 Wrong Marks : 1

0.36 m ବ୍ୟାସାର୍ଦ୍ଧ ବିଶିଷ୍ଟ ଗୋଟିଏ ବୃତ୍ତର ପରିଧିରେ ଗୋଟିଏ ବିନ୍ଦୁ A ସମବେଗରେ ଗତି କରୁଅଛି ଏବଂ 0.1 ସେକେଣ୍ଡରେ  $30^\circ$  ଅତିକ୍ରମ କରୁଛି । MN ବ୍ୟାସ ଉପରେ 'A' ରୁ ଲମ୍ବାୟ ପ୍ରକ୍ଷେପଣ (ପ୍ରୋଜେକ୍ସନ୍) P ର ସରଳ ହାରମୋନିକ୍ ଗତିକୁ ପ୍ରଦର୍ଶନ କରୁଅଛି । 'P' ଟି M କୁ ସ୍ପର୍ଶ କରିବା ସମୟରେ ଏକକ ବସ୍ତୁରୁ ପ୍ରତି ପୁନଃସ୍ଥାପନ (ରେଷ୍ଟୋରେସନ୍) ବଳଟି ହେବ,

\_\_\_\_\_ ।

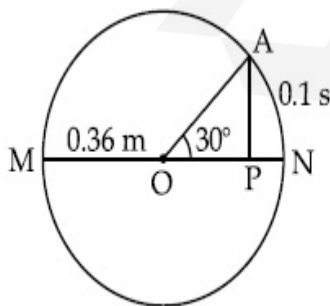

Options :

70819163583. 100 N

70819163584. 9.87 N

70819163585. 50 N

70819163586. 0.49 N

**Question Number : 5 Question Id : 70819119478 Question Type : MCQ Option Shuffling : Yes Is Question Mandatory : No**

**Correct Marks : 4 Wrong Marks : 1**

Thermodynamic process is shown below on a P-V diagram for one mole of an ideal gas. If  $V_2 = 2V_1$  then the ratio of temperature  $T_2/T_1$  is :

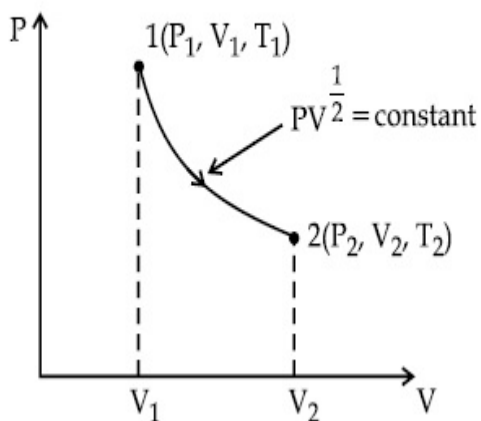

**Options :**

70819163587.  $\frac{1}{\sqrt{2}}$

70819163588.  $\sqrt{2}$

70819163589.  $\frac{1}{2}$

70819163590. 2

Question Number : 5 Question Id : 70819119478 Question Type : MCQ Option Shuffling : Yes Is

Question Mandatory : No

Correct Marks : 4 Wrong Marks : 1

ନିମ୍ନରେ ଦର୍ଶାଯାଇଥିବା ତାପଗତିକ ପ୍ରଣାଳୀଟି ଏକ ମୋଲ ବିଶିଷ୍ଟ ଗୋଟିଏ ଆଦର୍ଶ ଗ୍ୟାସ୍ ପାଇଁ P-V ରେଖାଚିତ୍ରକୁ ବୁଝାଇ ଅଛି । ଯଦି  $V_2 = 2V_1$ , ତେବେ ତାପମାତ୍ରାର ଅନୁପାତ  $T_2/T_1$  ହେଉଛି \_\_\_\_\_ ।

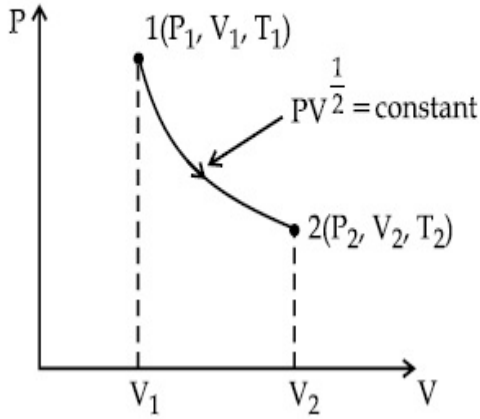

Options :

70819163587.  $\frac{1}{\sqrt{2}}$

70819163588.  $\sqrt{2}$

70819163589.  $\frac{1}{2}$

70819163590. 2

Question Number : 6 Question Id : 70819119479 Question Type : MCQ Option Shuffling : Yes Is

Question Mandatory : No

Correct Marks : 4 Wrong Marks : 1

Given below are two statements :

Statement I : In a diatomic molecule, the rotational energy at a given temperature obeys Maxwell's distribution.

Statement II : In a diatomic molecule, the rotational energy at a given temperature equals the translational kinetic energy for each molecule.

In the light of the above statements, choose the correct answer from the options given below :

Options :

70819163591. Both Statement I and Statement II are true.

70819163592. Both Statement I and Statement II are false.

70819163593. Statement I is true but Statement II is false.

70819163594. Statement I is false but Statement II is true.

**Question Number : 6 Question Id : 70819119479 Question Type : MCQ Option Shuffling : Yes Is**

**Question Mandatory : No**

**Correct Marks : 4 Wrong Marks : 1**

ନିମ୍ନରେ ଦୁଇଟି ଉକ୍ତି ଦିଆଯାଇଛି :

ଉକ୍ତି I : ଗୋଟିଏ ଦ୍ଵିପରମାଣୁକ ଅଣୁରେ, ଏକ ଦତ୍ତ ତାପମାତ୍ରାରେ ଘୂର୍ଣ୍ଣନ ଶକ୍ତି ମାକ୍ସୱେଲ୍‌ଙ୍କ ତିଷ୍ଟିବୁଦ୍ଧକୁ ମାନିଥାଏ ।

ଉକ୍ତି II : ଗୋଟିଏ ଦ୍ଵିପରମାଣୁକ ଅଣୁରେ, ଏକ ଦତ୍ତ ତାପମାତ୍ରାରେ ପ୍ରତ୍ୟେକ ଅଣୁ ପାଇଁ ଘୂର୍ଣ୍ଣନ ଶକ୍ତି ଗ୍ରାହ୍ୟଲେସନାଲ ଗତିକ ଶକ୍ତି ସହ ସମାନ ।

ଉପରୋକ୍ତ ଉକ୍ତିଗୁଡ଼ିକ ଅନୁସାରେ, ନିମ୍ନରେ ଦତ୍ତ ବିକଳ୍ପ ଗୁଡ଼ିକ ମଧ୍ୟରୁ ଠିକ୍ ଉତ୍ତରଟି ଚୟନ କର ।

**Options :**

70819163591. ଉଭୟ ଉକ୍ତି I ଏବଂ ଉକ୍ତି II ସତ୍ୟ ଅଟେ ।

70819163592. ଉଭୟ ଉକ୍ତି I ଏବଂ ଉକ୍ତି II ମିଥ୍ୟା ଅଟେ ।

70819163593. ଉକ୍ତି I ଠିକ୍ ଅଟେ କିନ୍ତୁ ଉକ୍ତି II ଠିକ୍ ମିଥ୍ୟା ଅଟେ ।

70819163594. ଉକ୍ତି I ଠିକ୍ କିନ୍ତୁ ଉକ୍ତି II ଠିକ୍ ସତ୍ୟ ଅଟେ ।

**Question Number : 7 Question Id : 70819119480 Question Type : MCQ Option Shuffling : Yes Is**

**Question Mandatory : No**

**Correct Marks : 4 Wrong Marks : 1**

Two identical springs of spring constant '2k' are attached to a block of mass m and to fixed support (see figure). When the mass is displaced from equilibrium position on either side, it executes simple harmonic motion. The time period of oscillations of this system is :

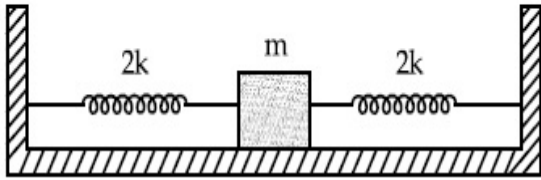

Options :

70819163595.  $2\pi \sqrt{\frac{m}{2k}}$

70819163596.  $2\pi \sqrt{\frac{m}{k}}$

70819163597.  $\pi \sqrt{\frac{m}{k}}$

70819163598.  $\pi \sqrt{\frac{m}{2k}}$

Question Number : 7 Question Id : 70819119480 Question Type : MCQ Option Shuffling : Yes Is

Question Mandatory : No

Correct Marks : 4 Wrong Marks : 1

'2k' ସ୍ପ୍ରିଙ୍ଗ୍ ଧୁବାକ ବିଶିଷ୍ଟ ଦୁଇଟି ଏକାଭଳିଆ ସ୍ପ୍ରିଙ୍ଗ୍‌କୁ m ବସ୍ତୁ ବିଶିଷ୍ଟ ଗୋଟିଏ ବ୍ଲକ୍ ଏବଂ ସ୍ଥିର ଭିତା(ସପୋର୍ଟ) ସହ ସଂଯୋଗ କରାଯାଇଛି । (ଚିତ୍ରଦେଖ) । ଯେତେବେଳେ ବସ୍ତୁଟି ସନ୍ତୁଳନ ସ୍ଥାନରୁ ଯେକୌଣସି ଦିଗରେ ବିସ୍ଥାପନ କରାଯାଏ, ଏହା ସରଳ ହାରମୋନିକ୍ ଗତି ସମ୍ପାଦନ କରିଥାଏ । ପ୍ରଣାଳୀଟିର ଦୋଳନର ଆବର୍ତ୍ତକାଳ ହେଉଛି :

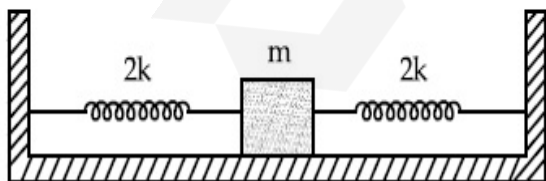

Options :

70819163595.  $2\pi \sqrt{\frac{m}{2k}}$

70819163596.  $2\pi \sqrt{\frac{m}{k}}$

70819163597.  $\pi \sqrt{\frac{m}{k}}$

70819163598.  $\pi \sqrt{\frac{m}{2k}}$

**Question Number : 8 Question Id : 70819119481 Question Type : MCQ Option Shuffling : Yes Is**

**Question Mandatory : No**

**Correct Marks : 4 Wrong Marks : 1**

$Y = A \sin(\omega t + \phi_0)$  is the time-displacement equation of a SHM. At  $t=0$  the displacement of the particle is  $Y = \frac{A}{2}$  and it is moving along negative  $x$ -direction. Then the initial phase angle  $\phi_0$  will be :

**Options :**

70819163599.  $\frac{\pi}{3}$

70819163600.  $\frac{5\pi}{6}$

70819163601.  $\frac{\pi}{6}$

70819163602.  $\frac{2\pi}{3}$

**Question Number : 8 Question Id : 70819119481 Question Type : MCQ Option Shuffling : Yes Is**

**Question Mandatory : No**

Correct Marks : 4 Wrong Marks : 1

$Y = A \sin(\omega t + \phi_0)$  ଗୋଟିଏ ସରଳ ହାରମୋନିକ୍ ଗତି (ଏସ୍.ଏର୍.ଏମ୍.) ର ସମୟ-ବିସ୍ଥାପନ ସମୀକରଣ ଅଟେ ।  $t=0$

ସମୟରେ କଣିକାଟିର ବିସ୍ଥାପନ  $Y = \frac{A}{2}$  ଅଟେ ଏବଂ ଏହା  $x$ -ଅକ୍ଷର ଋଣାତ୍ମକ ଦିଗରେ ଗତି କରୁଛି । ତେବେ ପ୍ରାରମ୍ଭିକ ଫେଜ୍

କୋଣ  $\phi_0$  ହେବ \_\_\_\_\_ ।

Options :

70819163599.  $\frac{\pi}{3}$

70819163600.  $\frac{5\pi}{6}$

70819163601.  $\frac{\pi}{6}$

70819163602.  $\frac{2\pi}{3}$

Question Number : 9 Question Id : 70819119482 Question Type : MCQ Option Shuffling : Yes Is

Question Mandatory : No

Correct Marks : 4 Wrong Marks : 1

A charge 'q' is placed at one corner of a cube as shown in figure. The flux of electrostatic field

$\vec{E}$  through the shaded area is :

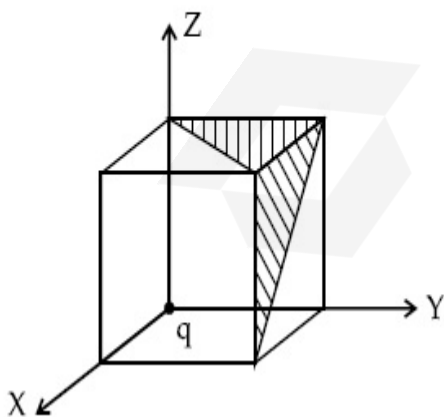

Options :

70819163603.  $\frac{q}{48\epsilon_0}$

70819163604.  $\frac{q}{4\epsilon_0}$

70819163605.  $\frac{q}{8\epsilon_0}$

70819163606.  $\frac{q}{24\epsilon_0}$

**Question Number : 9 Question Id : 70819119482 Question Type : MCQ Option Shuffling : Yes Is Question Mandatory : No**

**Correct Marks : 4 Wrong Marks : 1**

ଗୋଟିଏ ଚାର୍ଜ 'q' ଏକ ସମଘନର ଗୋଟିଏ କୋଣରେ ଚିତ୍ରରେ ଦର୍ଶାଯାଇଥିବା ଅନୁସାରେ ରଖାଯାଇଛି । ଚିତ୍ରିତ (ସେତେବଦ୍)

ପୃଷ୍ଠ ଦେଇ ଯାଉଥିବା ବୈଦ୍ୟୁତିକ କ୍ଷେତ୍ର ( $\vec{E}$ ) ର ଅଭିବାହ (ଫ୍ଲକ୍ସ) ହେଉଛି \_\_\_\_\_ ।

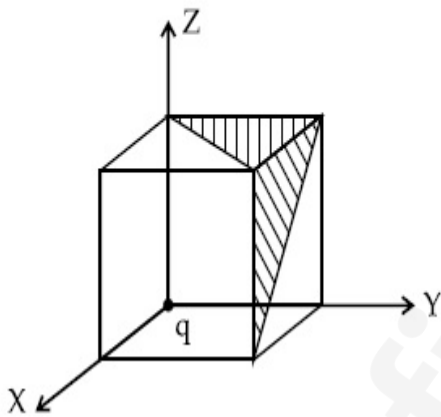

**Options :**

70819163603.  $\frac{q}{48\epsilon_0}$

70819163604.  $\frac{q}{4\epsilon_0}$

70819163605.  $\frac{q}{8\epsilon_0}$

70819163606.  $\frac{q}{24\epsilon_0}$

Question Number : 10 Question Id : 70819119483 Question Type : MCQ Option Shuffling : Yes

Is Question Mandatory : No

Correct Marks : 4 Wrong Marks : 1

An electron with kinetic energy  $K_1$  enters between parallel plates of a capacitor at an angle ' $\alpha$ ' with the plates. It leaves the plates at angle ' $\beta$ ' with kinetic energy  $K_2$ . Then the ratio of kinetic energies  $K_1 : K_2$  will be :

Options :

70819163607.  $\frac{\cos\beta}{\cos\alpha}$

70819163608.  $\frac{\cos\beta}{\sin\alpha}$

70819163609.  $\frac{\sin^2\beta}{\cos^2\alpha}$

70819163610.  $\frac{\cos^2\beta}{\cos^2\alpha}$

Question Number : 10 Question Id : 70819119483 Question Type : MCQ Option Shuffling : Yes

Is Question Mandatory : No

Correct Marks : 4 Wrong Marks : 1

$K_1$  ଗତିଜ ଶକ୍ତି ସହ ଏକ ଇଲେକ୍ଟ୍ରନ୍ ଗୋଟିଏ ଧାରିତ୍ରର ସମାନ୍ତର ପ୍ଲେଟ୍ ମଧ୍ୟରେ ପ୍ଲେଟ୍ ସହ ' $\alpha$ ' କୋଣରେ ପ୍ରବେଶ କରୁଛି । ଏହା  $K_2$  ଗତିଜ ଶକ୍ତି ସହ ' $\beta$ ' କୋଣରେ ପ୍ଲେଟ୍ ମଧ୍ୟରୁ ବାହାରି ଯାଉଛି । ତେବେ ଗତିଜ ଶକ୍ତିର ଅନୁପାତ  $K_1 : K_2$  ହେବ \_\_\_\_\_ ।

Options :

70819163607.  $\frac{\cos\beta}{\cos\alpha}$

70819163608.  $\frac{\cos\beta}{\sin\alpha}$

70819163609.  $\frac{\sin^2\beta}{\cos^2\alpha}$

70819163610.  $\frac{\cos^2\beta}{\cos^2\alpha}$

**Question Number : 11 Question Id : 70819119484 Question Type : MCQ Option Shuffling : Yes**

**Is Question Mandatory : No**

**Correct Marks : 4 Wrong Marks : 1**

In a ferromagnetic material, below the curie temperature, a domain is defined as :

**Options :**

70819163611. a macroscopic region with zero magnetization.

70819163612. a macroscopic region with saturation magnetization.

70819163613. a macroscopic region with randomly oriented magnetic dipoles.

70819163614. a macroscopic region with consecutive magnetic dipoles oriented in opposite direction.

**Question Number : 11 Question Id : 70819119484 Question Type : MCQ Option Shuffling : Yes**

**Is Question Mandatory : No**

**Correct Marks : 4 Wrong Marks : 1**

ଗୋଟିଏ ଲୌହ ତୁମ୍ବକୀୟ ପଦାର୍ଥରେ, କ୍ୟୁରୀ ତାପମାତ୍ରା ତଳେ ତୁମ୍ବକୀୟ ପରିସର (ଡାମେନ୍)କୁ ଏହି ପ୍ରକାର ବ୍ୟାଖ୍ୟା କରାଯାଇଥାଏ,

**Options :**

70819163611. ଶୂନ୍ୟ ରୁମ୍ଭକନ (ମଧ୍ୟାନ୍ତେଗାଲଜେସନ) ସହ ଏକ ସ୍ଥଳଦର୍ଶୀୟ କ୍ଷେତ୍ର ମାନ୍ତ୍ରେୟାଦିର (ପିଏସ୍.ଏଚ୍.)

70819163612. ସଂତୃପ୍ତି (ସାଚୁରେସନ) ରୁମ୍ଭକନ ସହ ଏକ ସ୍ଥଳଦର୍ଶୀୟ କ୍ଷେତ୍ର ।

70819163613. ଅନିୟମିତ ଭାବେ ବୁଲି ଅବସ୍ଥାପିତ ରୁମ୍ଭକୀୟ ଦ୍ୱିଧ୍ରୁବ ଥିବା ଏକ ସ୍ଥଳଦର୍ଶୀୟ କ୍ଷେତ୍ର ।

70819163614. ବିପରୀତ ଦିଗରେ ଅବସ୍ଥାପିତ ପାଖାପାଖି ରୁମ୍ଭକୀୟ ଦ୍ୱିଧ୍ରୁବ ଥିବା ଏକ ସ୍ଥଳଦର୍ଶୀୟ କ୍ଷେତ୍ର ।

**Question Number : 12 Question Id : 70819119485 Question Type : MCQ Option Shuffling : Yes**

**Is Question Mandatory : No**

**Correct Marks : 4 Wrong Marks : 1**

An LCR circuit contains resistance of  $110 \Omega$  and a supply of  $220 \text{ V}$  at  $300 \text{ rad/s}$  angular frequency. If only capacitance is removed from the circuit, current lags behind the voltage by  $45^\circ$ . If on the other hand, only inductor is removed the current leads by  $45^\circ$  with the applied voltage. The rms current flowing in the circuit will be :

**Options :**

70819163615. 1 A

70819163616. 1.5 A

70819163617. 2 A

70819163618. 2.5 A

**Question Number : 12 Question Id : 70819119485 Question Type : MCQ Option Shuffling : Yes**

**Is Question Mandatory : No**

**Correct Marks : 4 Wrong Marks : 1**

କୌଣସି ଆବୃତ୍ତି  $300 \text{ rad/s}$  ରେ ଗୋଟିଏ LCR ପରିପଥରେ  $110 \Omega$  ର ପ୍ରତିରୋଧ ଏବଂ  $220 \text{ V}$  ର ଏକ ବିଦ୍ୟୁତ୍ ଚାଳକ ଧାରିତ୍ରୀକୁ ପରିପଥଟିରୁ ବାହାର କରି ଦିଆଯାଏ, ବିଦ୍ୟୁତ୍ ସ୍ରୋତ ଭୋଲଟେଜ୍ ପଛକୁ  $45^\circ$  ରେ ରହିବ । ଅନ୍ୟ କ୍ଷେତ୍ରରେ, କେବଳ ପ୍ରଶୋଦକକୁ ପରିପଥଟିରୁ ବାହାର କରିଦେଲେ ବିଦ୍ୟୁତ୍ ସ୍ରୋତ ପ୍ରୟୋଗାତ୍ମକ ଭୋଲଟେଜ୍ ଠାରୁ  $45^\circ$  ଆଗକୁ ରହିବ । ପରିପଥଟିରେ ପ୍ରବାହିତ ବିଦ୍ୟୁତ୍ ସ୍ରୋତର ମାଧ୍ୟବର୍ତ୍ତର ବର୍ଗମୂଳ ମୂଲ୍ୟ ହେବ :

**Options :**

70819163615. 1 A

70819163616. 1.5 A

70819163617. 2 A

70819163618. 2.5 A

**Question Number : 13 Question Id : 70819119486 Question Type : MCQ Option Shuffling : Yes**

**Is Question Mandatory : No**

**Correct Marks : 4 Wrong Marks : 1**

The stopping potential for electrons emitted from a photosensitive surface illuminated by light of wavelength  $491 \text{ nm}$  is  $0.710 \text{ V}$ . When the incident wavelength is changed to a new value, the stopping potential is  $1.43 \text{ V}$ . The new wavelength is :

**Options :**

70819163619. 309 nm

70819163620. 329 nm

70819163621. 382 nm

70819163622. 400 nm

**Question Number : 13 Question Id : 70819119486 Question Type : MCQ Option Shuffling : Yes**

**Is Question Mandatory : No**

Correct Marks : 4 Wrong Marks : 1

491 nm ତରଙ୍ଗ ଦୈର୍ଘ୍ୟ ବିଶିଷ୍ଟ ଏକ ଆଲୋକ ରଶ୍ମି ଦ୍ୱାରା ଆଲୋକିତ ଗୋଟିଏ ଆଲୋକ ସଂବେଦୀ ପୃଷ୍ଠରୁ ଉତ୍ପନ୍ନ ଉତ୍ତରଣ ଲଲେକ୍ତ୍ରୋନ୍ ପାଇଁ ରହିତକରଣ ବିଭବ (ଷ୍ଟପିଙ୍ଗ୍ ପୋଟେନ୍ସିଆଲ) 0.710 V ଅଟେ । ଯେତେବେଳେ ଆପତିତ ତରଙ୍ଗ ଦୈର୍ଘ୍ୟ ଗୋଟିଏ ନୂତନ ମୂଲ୍ୟକୁ ପରିବର୍ତ୍ତନ ହୋଇଥାଏ । ରହିତକରଣ ବିଭବ 1.43 V ଅଟେ । ନୂତନ ତରଙ୍ଗ ଦୈର୍ଘ୍ୟ ଅଟେ \_\_\_\_\_ ।

Options :

70819163619. 309 nm

70819163620. 329 nm

70819163621. 382 nm

70819163622. 400 nm

Question Number : 14 Question Id : 70819119487 Question Type : MCQ Option Shuffling : Yes

Is Question Mandatory : No

Correct Marks : 4 Wrong Marks : 1

Consider the diffraction pattern obtained from the sunlight incident on a pinhole of diameter  $0.1 \mu\text{m}$ . If the diameter of the pinhole is slightly increased, it will affect the diffraction pattern such that :

Options :

70819163623. its size increases, and intensity increases

70819163624. its size increases, but intensity decreases

70819163625. its size decreases, but intensity increases

70819163626. its size decreases, and intensity decreases

Question Number : 14 Question Id : 70819119487 Question Type : MCQ Option Shuffling : Yes

Is Question Mandatory : No

Correct Marks : 4 Wrong Marks : 1

0.1  $\mu\text{m}$  ବ୍ୟାସ ବିଶିଷ୍ଟ ଏକ ସୂକ୍ଷ୍ମ ରନ୍ଧ୍ର (ପିନ୍ ହୋଲ) ରେ ସୂର୍ଯ୍ୟକିରଣ ପଡ଼ି ହେଉଥିବା ବିକୀର୍ଣ୍ଣନ ବିନ୍ୟାସକୁ ବିବେଚନା କର । ଯଦି ସୂକ୍ଷ୍ମ ରନ୍ଧ୍ରଟିର ବ୍ୟାସରେ ସାମାନ୍ୟ ବୃଦ୍ଧି ଘଟେ, ଏହା ବିକୀର୍ଣ୍ଣନ ବିନ୍ୟାସକୁ ଏମିତି ପ୍ରଭାବିତ କରିବ ଯେମିତି,

Options :

70819163623. ଏହାର ଆକାର ବୃଦ୍ଧି ପାଏ ଏବଂ ତୀବ୍ରତା ବୃଦ୍ଧି ପାଇଥାଏ ।

70819163624. ଏହାର ଆକାର ବୃଦ୍ଧି ପାଏ କିନ୍ତୁ ତୀବ୍ରତା କମିଯାଇଥାଏ ।

70819163625. ଏହାର ଆକାର କମିଯାଏ କିନ୍ତୁ ତୀବ୍ରତା ବଢ଼ିଥାଏ ।

70819163626. ଏହାର ଆକାର କମିଯାଏ ଏବଂ ତୀବ୍ରତା କମିଯାଏ ।

Question Number : 15 Question Id : 70819119488 Question Type : MCQ Option Shuffling : Yes

Is Question Mandatory : No

Correct Marks : 4 Wrong Marks : 1

An electron of mass  $m_e$  and a proton of mass  $m_p = 1836 m_e$  are moving with the same speed.

The ratio of their de Broglie wavelength  $\frac{\lambda_{\text{electron}}}{\lambda_{\text{proton}}}$  will be :

Options :

70819163627. 1

70819163628. 1836

70819163629.  $\frac{1}{1836}$

70819163630. 918

Question Number : 15 Question Id : 70819119488 Question Type : MCQ Option Shuffling : Yes

Is Question Mandatory : No

Correct Marks : 4 Wrong Marks : 1

ବସ୍ତୁରୁ  $m_e$  ବିଶିଷ୍ଟ ଗୋଟିଏ ଇଲେକ୍ଟ୍ରନ୍ ଏବଂ  $m_p = 1836 m_e$  ବସ୍ତୁରୁ ବିଶିଷ୍ଟ ଗୋଟିଏ ପ୍ରୋଟନ୍ ସମାନ ବେଗରେ ଗତି କରୁଛନ୍ତି ।

ସେମାନଙ୍କର ତିବ୍ରୋତ୍ତା ଚରଣ ଦୈର୍ଘ୍ୟର ଅନୁପାତ  $\frac{\lambda_{ଇଲେକ୍ଟ୍ରନ୍}}{\lambda_{ପ୍ରୋଟନ୍}}$  ହେବ :

Options :

70819163627. 1

70819163628. 1836

70819163629.  $\frac{1}{1836}$

70819163630. 918

Question Number : 16 Question Id : 70819119489 Question Type : MCQ Option Shuffling : Yes

Is Question Mandatory : No

Correct Marks : 4 Wrong Marks : 1

The wavelength of the photon emitted by a hydrogen atom when an electron makes a transition from  $n=2$  to  $n=1$  state is :

Options :

70819163631. 121.8 nm

70819163632. 194.8 nm

70819163633. 490.7 nm

70819163634. 913.3 nm

Question Number : 16 Question Id : 70819119489 Question Type : MCQ Option Shuffling : Yes

Is Question Mandatory : No

Correct Marks : 4 Wrong Marks : 1

ଯେତେବେଳେ ଏକ ଇଲେକ୍ଟ୍ରନ୍  $n=2$  ରୁ  $n=1$  ଶକ୍ତିସ୍ତରକୁ ଅବସ୍ଥାନ୍ତର କରିଥାଏ, ସେତେବେଳେ ଗୋଟିଏ ଉଦ୍‌ୟାନ ପରମାଣୁ ଦ୍ୱାରା ଉତ୍ସର୍ଜିତ ଫୋଟନ୍‌ର ତରଙ୍ଗ ଦୈର୍ଘ୍ୟ ହେଉଛି \_\_\_\_\_ ।

Options :

70819163631. 121.8 nm

70819163632. 194.8 nm

70819163633. 490.7 nm

70819163634. 913.3 nm

Question Number : 17 Question Id : 70819119490 Question Type : MCQ Option Shuffling : Yes

Is Question Mandatory : No

Correct Marks : 4 Wrong Marks : 1

If a message signal of frequency ' $f_m$ ' is amplitude modulated with a carrier signal of frequency ' $f_c$ ' and radiated through an antenna, the wavelength of the corresponding signal in air is :

Options :

70819163635.  $\frac{c}{f_c - f_m}$

70819163636.  $\frac{c}{f_c + f_m}$

70819163637.  $\frac{c}{f_c}$

70819163638.

$$\frac{c}{f_m}$$

Question Number : 17 Question Id : 70819119490 Question Type : MCQ Option Shuffling : Yes

Is Question Mandatory : No

Correct Marks : 4 Wrong Marks : 1

ଯଦି ' $f_m$ ' ଆବୃତ୍ତି ବିଶିଷ୍ଟ ଗୋଟିଏ ବାର୍ତ୍ତା ସଂକେତ ' $f_c$ ' ଆବୃତ୍ତି ବିଶିଷ୍ଟ ଗୋଟିଏ ବାହକ ସଂକେତ ସହ ଆକ୍ଷାମ ମୋଡୁଲନ କରାଯାଏ ଏବଂ ଗୋଟିଏ ଆକ୍ଷେପା ଦେଇ ବିକିରଣ କରାଯାଏ, ବାୟୁମଣ୍ଡଳରେ ସଂପୃକ୍ତ ସଂକେତ (ସିଗ୍ନାଲ) ଚିର ଡରଙ୍ଗ ବୈଶ୍ଣ୍ୟ ହେବ :

Options :

70819163635.  $\frac{c}{f_c - f_m}$

70819163636.  $\frac{c}{f_c + f_m}$

70819163637.  $\frac{c}{f_c}$

70819163638.  $\frac{c}{f_m}$

Question Number : 18 Question Id : 70819119491 Question Type : MCQ Option Shuffling : Yes

Is Question Mandatory : No

Correct Marks : 4 Wrong Marks : 1

For extrinsic semiconductors; when doping level is increased;

Options :

70819163639. Fermi-level of p-type semiconductor will go upward and Fermi-level of n-type semiconductors will go downward.

70819163640.

Fermi-level of p-type semiconductors will go downward and Fermi-level of n-type semiconductor will go upward.

70819163641. Fermi-level of p and n-type semiconductors will not be affected.

70819163642. Fermi-level of both p-type and n-type semiconductors will go upward for  $T > T_F$  K and downward for  $T < T_F$  K, where  $T_F$  is Fermi temperature.

Question Number : 18 Question Id : 70819119491 Question Type : MCQ Option Shuffling : Yes

Is Question Mandatory : No

Correct Marks : 4 Wrong Marks : 1

ବହିର୍ଜାତ ଅର୍ଦ୍ଧ ପରିବାହୀ ପାଇଁ ଯେତେବେଳେ ଅବଲେପନ (ଡୋପିଙ୍ଗ) ସ୍ତର ବୃଦ୍ଧି କରାଯାଏ,

Options :

70819163639. p-ଶ୍ରେଣୀ ଅର୍ଦ୍ଧ ପରିବାହୀର ଫରମିଲେବଲ୍ ଉପରକୁ ଉଠିବ ଏବଂ n-ଶ୍ରେଣୀ ଅର୍ଦ୍ଧପରିବାହୀର ଫରମିଲେବଲ୍ ତଳକୁ ଖସିବ ।

70819163640. p-ଶ୍ରେଣୀ ଅର୍ଦ୍ଧ ପରିବାହୀର ଫରମିଲେବଲ୍ ତଳକୁ ଖସିବ ଏବଂ n-ଶ୍ରେଣୀ ଅର୍ଦ୍ଧପରିବାହୀର ଫରମିଲେବଲ୍ ଉପରକୁ ଉଠିବ ।

70819163641. p-ଶ୍ରେଣୀ ଏବଂ n-ଶ୍ରେଣୀ ଅର୍ଦ୍ଧ ପରିବାହୀର ଫରମିଲେବଲ୍ ପ୍ରଭାବିତ ହେବନାହିଁ ।

70819163642. ଉଭୟ p-ଶ୍ରେଣୀ ଓ n-ଶ୍ରେଣୀ ଅର୍ଦ୍ଧ ପରିବାହୀର ଫରମିଲେବଲ୍  $T > T_F$  K ପାଇଁ ଉପରକୁ ଉଠିଯିବ ଏବଂ  $T < T_F$  K ପାଇଁ ତଳକୁ ଖସିଯିବ, ଯେଉଁଠାରେ  $T_F$  ଫରମି ତାପମାତ୍ରା ଅଟେ ।

Question Number : 19 Question Id : 70819119492 Question Type : MCQ Option Shuffling : Yes

Is Question Mandatory : No

Correct Marks : 4 Wrong Marks : 1

Match List I with List II.

List I	List II
(a) Rectifier	(i) Used either for stepping up or stepping down the a.c. voltage
(b) Stabilizer	(ii) Used to convert a.c. voltage into d.c. voltage
(c) Transformer	(iii) Used to remove any ripple in the rectified output voltage
(d) Filter	(iv) Used for constant output voltage even when the input voltage or load current change

Choose the correct answer from the options given below :

**Options :**

70819163643. (a)-(ii), (b)-(i), (c)-(iii), (d)-(iv)

70819163644. (a)-(ii), (b)-(iv), (c)-(i), (d)-(iii)

70819163645. (a)-(ii), (b)-(i), (c)-(iv), (d)-(iii)

70819163646. (a)-(iii), (b)-(iv), (c)-(i), (d)-(ii)

**Question Number : 19 Question Id : 70819119492 Question Type : MCQ Option Shuffling : Yes**

**Is Question Mandatory : No**

**Correct Marks : 4 Wrong Marks : 1**

ତାଲିକା I ସହ ତାଲିକା II କୁ ମିଳାଅ :

ତାଲିକା - I	ତାଲିକା - II
(a) ରେକ୍ଟିଫାୟାର	(i) ଏ.ସି. ଭୋଲ୍ଟେଜ୍‌କୁ ବତାଇବା ପାଇଁ କିମ୍ବା କମାଇବା ପାଇଁ ବ୍ୟବହାର କରାଯାଏ ।
(b) ସ୍ଥାୟୀକାରୀ (ଷ୍ଟାବିଲାଇଜେର)	(ii) ଏ.ସି. ଭୋଲ୍ଟେଜ୍‌କୁ ଡି.ସି. ଭୋଲ୍ଟେଜ୍‌ରେ ପରିଣତ କରିବା ପାଇଁ ବ୍ୟବହୃତ ହୋଇଥାଏ ।
(c) ଟ୍ରାନ୍ସଫର୍ମର	(iii) ରେକ୍ଟିଫାଏଡ୍ ବର୍ହିବେଶ ଭୋଲ୍ଟେଜ୍‌ରେ ଥିବା କୌଣସି ରିପଲ୍‌କୁ ହଟାଇବା ପାଇଁ ବ୍ୟବହାର କରାଯାଏ ।
(d) ଫିଲ୍ଟର	(iv) ସ୍ଥିର ବର୍ହିବେଶ ଭୋଲ୍ଟେଜ୍ ପାଇଁ ବ୍ୟବହାର କରାଯାଏ ଏପରିକି ଯେତେବେଳେ ନିବେଶ ଭୋଲ୍ଟେଜ୍ କିମ୍ବା ଲୋଡ୍ ବିଦ୍ୟୁତ୍ ସ୍ରୋତରେ ପରିବର୍ତ୍ତନ ହେଉଥାଏ ।

ନିମ୍ନରେ ଦିଆଯାଇଥିବା ବିକଳ୍ପ ମଧ୍ୟରୁ ଠିକ୍ ଉତ୍ତରଟି ଚୟନ କର :

**Options :**

70819163643. (a)-(ii), (b)-(i), (c)-(iii), (d)-(iv)

70819163644. (a)-(ii), (b)-(iv), (c)-(i), (d)-(iii)

70819163645. (a)-(ii), (b)-(i), (c)-(iv), (d)-(iii)

70819163646. (a)-(iii), (b)-(iv), (c)-(i), (d)-(ii)

**Question Number : 20 Question Id : 70819119493 Question Type : MCQ Option Shuffling : Yes**

**Is Question Mandatory : No**

**Correct Marks : 4 Wrong Marks : 1**

The truth table for the following logic circuit is :

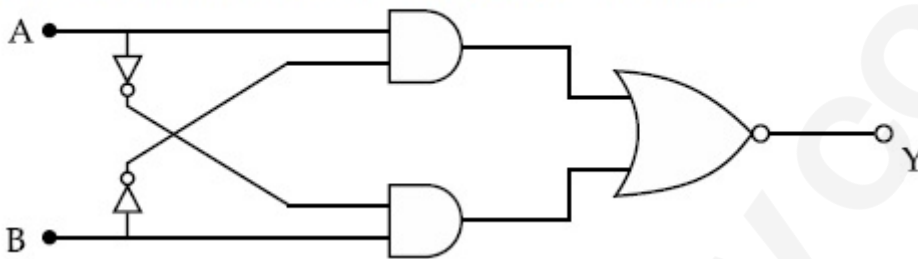

**Options :**

A	B	Y
0	0	0
0	1	1
1	0	1
1	1	0

70819163647.

A	B	Y
0	0	1
0	1	0
1	0	0
1	1	1

70819163648.

70819163649.

A	B	Y
0	0	1
0	1	0
1	0	1
1	1	0

A	B	Y
0	0	0
0	1	1
1	0	0
1	1	1

70819163650.

Question Number : 20 Question Id : 70819119493 Question Type : MCQ Option Shuffling : Yes

Is Question Mandatory : No

Correct Marks : 4 Wrong Marks : 1

ନିମ୍ନଲିଖିତ ଲଜିକ୍ ଗେଟ୍ ପରିପଥ ପାଇଁ ସତ୍ୟମାନ ସାରଣୀ ହେଉଛି :

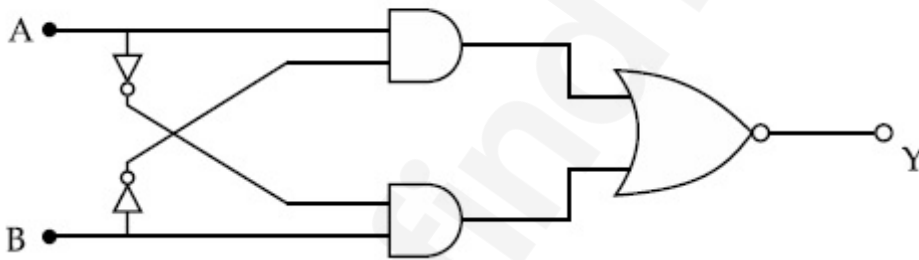

Options :

A	B	Y
0	0	0
0	1	1
1	0	1
1	1	0

70819163647.

70819163648.

A	B	Y
0	0	1
0	1	0
1	0	0
1	1	1

A	B	Y
0	0	1
0	1	0
1	0	1
1	1	0

70819163649.

A	B	Y
0	0	0
0	1	1
1	0	0
1	1	1

70819163650.

## Physics Section B

<b>Section Id :</b>	708191839
<b>Section Number :</b>	2
<b>Section type :</b>	Online
<b>Mandatory or Optional :</b>	Mandatory
<b>Number of Questions :</b>	10
<b>Number of Questions to be attempted :</b>	5
<b>Section Marks :</b>	20
<b>Mark As Answered Required? :</b>	Yes
<b>Sub-Section Number :</b>	1

Sub-Section Id :

70819111

Question Shuffling Allowed :

Yes

Question Number : 21 Question Id : 70819119494 Question Type : SA

Correct Marks : 4 Wrong Marks : 0

Two particles having masses 4 g and 16 g respectively are moving with equal kinetic energies. The ratio of the magnitudes of their linear momentum is  $n : 2$ . The value of  $n$  will be \_\_\_\_\_.

Response Type : Numeric

Evaluation Required For SA : Yes

Show Word Count : Yes

Answers Type : Range

Text Areas : PlainText

Possible Answers :

5 to 5.001

Question Number : 21 Question Id : 70819119494 Question Type : SA

Correct Marks : 4 Wrong Marks : 0

ଯଥାକ୍ରମେ 4 gm ଏବଂ 16 gm ବସ୍ତୁ ଦ୍ଵିଶିଷ୍ଟ ଦୁଇଟି କଣିକା ସମାନ ଗତିକ ଶକ୍ତିରେ ଗତି କରୁଛନ୍ତି । ସେମାନଙ୍କର ରେଖୀୟ ସମେଶ ପରିମାଣର ଅନୁପାତ  $n : 2$  ଅଟେ ।  $n$  ର ମୂଲ୍ୟ ହେବ \_\_\_\_\_ ।

Response Type : Numeric

Evaluation Required For SA : Yes

Show Word Count : Yes

Answers Type : Range

Text Areas : PlainText

Possible Answers :

5 to 5.001

Question Number : 22 Question Id : 70819119495 Question Type : SA

Correct Marks : 4 Wrong Marks : 0

The initial velocity  $v_i$  required to project a body vertically upward from the surface of the earth to reach a height of  $10R$ , where  $R$  is the radius of the earth, may be described in terms

of escape velocity  $v_e$  such that  $v_i = \sqrt{\frac{x}{y}} \times v_e$ . The value of  $x$  will be \_\_\_\_\_.

**Response Type :** Numeric

**Evaluation Required For SA :** Yes

**Show Word Count :** Yes

**Answers Type :** Range

**Text Areas :** PlainText

**Possible Answers :**

5 to 5.001

**Question Number :** 22 **Question Id :** 70819119495 **Question Type :** SA

**Correct Marks :** 4 **Wrong Marks :** 0

$10R$ , ଯେଉଁଠାରେ  $R$  ପୃଥିବୀର ବ୍ୟାସାର୍ଦ୍ଧ ଅଟେ, ଉଚ୍ଚତାରେ ପହଞ୍ଚାଇବା ପାଇଁ ଗୋଟିଏ ବସ୍ତୁକୁ ପୃଥିବୀ ପୃଷ୍ଠରୁ ଭୂଲମ୍ବୀୟ ଭାବେ ପ୍ରକ୍ଷେପ କରିବା ପାଇଁ ଆବଶ୍ୟକ ପଡୁଥିବା ପ୍ରାରମ୍ଭିକ ବେଗ  $v_i$  କୁ ପରିନିର୍ଗମନ ପରିବେଗ  $v_e$  ଆକାରରେ ପ୍ରକାଶ

କରାଯାଇପାରେ ଯେମିତି  $v_i = \sqrt{\frac{x}{y}} \times v_e$  ।  $x$  ର ମୂଲ୍ୟ \_\_\_\_\_ ଅଟେ ।

**Response Type :** Numeric

**Evaluation Required For SA :** Yes

**Show Word Count :** Yes

**Answers Type :** Range

**Text Areas :** PlainText

**Possible Answers :**

5 to 5.001

**Question Number :** 23 **Question Id :** 70819119496 **Question Type :** SA

**Correct Marks :** 4 **Wrong Marks :** 0

The percentage increase in the speed of transverse waves produced in a stretched string if the tension is increased by 4%, will be \_\_\_\_\_%.

**Response Type :** Numeric

**Evaluation Required For SA :** Yes

**Show Word Count :** Yes

**Answers Type :** Range

**Text Areas :** PlainText

**Possible Answers :**

5 to 5.001

**Question Number :** 23 **Question Id :** 70819119496 **Question Type :** SA

**Correct Marks :** 4 **Wrong Marks :** 0

ଯଦି ଶଶା ହୋଇଥିବା ଏକ ସୂତାରେ ତାର (ଚେନ୍‌ସର୍) 4% ବୃଦ୍ଧିପାଏ, ତେବେ ଏଥିରେ ସୃଷ୍ଟି ହେଉଥିବା ଅନୁପ୍ରସ୍ଥ ତରଙ୍ଗର ବେଗ ଶତକଡ଼ା ବୃଦ୍ଧି ହେବ \_\_\_\_\_%।

**Response Type :** Numeric

**Evaluation Required For SA :** Yes

**Show Word Count :** Yes

**Answers Type :** Range

**Text Areas :** PlainText

**Possible Answers :**

5 to 5.001

**Question Number :** 24 **Question Id :** 70819119497 **Question Type :** SA

**Correct Marks :** 4 **Wrong Marks :** 0

If  $\vec{P} \times \vec{Q} = \vec{Q} \times \vec{P}$ , the angle between  $\vec{P}$  and  $\vec{Q}$  is  $\theta$  ( $0^\circ < \theta < 360^\circ$ ). The value of ' $\theta$ ' will be \_\_\_\_\_ $^\circ$ .

**Response Type :** Numeric

**Evaluation Required For SA :** Yes

**Show Word Count :** Yes

**Answers Type :** Range

**Text Areas :** PlainText

**Possible Answers :**

5 to 5.001

Question Number : 24 Question Id : 70819119497 Question Type : SA

Correct Marks : 4 Wrong Marks : 0

ଯଦି  $\vec{P} \times \vec{Q} = \vec{Q} \times \vec{P}$ ,  $\vec{P}$  ଓ  $\vec{Q}$  ମଧ୍ୟରେ କୋଣ  $\theta$  ( $0^\circ < \theta < 360^\circ$ ) ଅଟେ । ' $\theta$ ' ର ମୂଲ୍ୟ \_\_\_\_\_  
ହେବ ।

Response Type : Numeric

Evaluation Required For SA : Yes

Show Word Count : Yes

Answers Type : Range

Text Areas : PlainText

Possible Answers :

5 to 5.001

Question Number : 25 Question Id : 70819119498 Question Type : SA

Correct Marks : 4 Wrong Marks : 0

A reversible heat engine converts one-fourth of the heat input into work. When the temperature of the sink is reduced by 52 K, its efficiency is doubled. The temperature in Kelvin of the source will be \_\_\_\_\_.

Response Type : Numeric

Evaluation Required For SA : Yes

Show Word Count : Yes

Answers Type : Range

Text Areas : PlainText

Possible Answers :

5 to 5.001

Question Number : 25 Question Id : 70819119498 Question Type : SA

Correct Marks : 4 Wrong Marks : 0

ଗୋଟିଏ ପ୍ରତ୍ୟାବର୍ତ୍ତୀ ତାପ ଇଞ୍ଜିନ୍ ଗ୍ରାହ୍ୟ (ଇନ୍ପୁଟ୍) ତାପର ଏକ ଚତୁର୍ଥାଂଶକୁ କାର୍ଯ୍ୟରେ ପରିଣତ କରେ । ଯେତେବେଳେ ସିଙ୍କ ତାପମାତ୍ରା 52 K କମିଯାଏ, ଏହାର ଦକ୍ଷତା ଦୁଇଗୁଣ ହୋଇଯାଏ । ଉତ୍ସ ଓ ତାପମାତ୍ରା କେଲ୍ଭିନ୍ରେ \_\_\_\_\_ ହେବ ।

Response Type : Numeric

**Evaluation Required For SA :** Yes

**Show Word Count :** Yes

**Answers Type :** Range

**Text Areas :** PlainText

**Possible Answers :**

5 to 5.001

**Question Number :** 26 **Question Id :** 70819119499 **Question Type :** SA

**Correct Marks :** 4 **Wrong Marks :** 0

Two small spheres each of mass 10 mg are suspended from a point by threads 0.5 m long. They are equally charged and repel each other to a distance of 0.20 m. The charge on each of

the sphere is  $\frac{a}{21} \times 10^{-8}$  C. The value of 'a' will be \_\_\_\_\_.

[Given  $g = 10 \text{ ms}^{-2}$ ]

**Response Type :** Numeric

**Evaluation Required For SA :** Yes

**Show Word Count :** Yes

**Answers Type :** Range

**Text Areas :** PlainText

**Possible Answers :**

5 to 5.001

**Question Number :** 26 **Question Id :** 70819119499 **Question Type :** SA

**Correct Marks :** 4 **Wrong Marks :** 0

ପ୍ରତ୍ୟେକ 10 mg ବସ୍ତୁ ବିଶିଷ୍ଟ ଦୁଇଟି ଛୋଟ ଗୋଲକକୁ 0.5 m ଦୈର୍ଘ୍ୟ ବିଶିଷ୍ଟ ସୂତାଗୁଡ଼ିକ ଦ୍ୱାରା ଗୋଟିଏ ବିନ୍ଦୁରେ ଝୁଲାଇ ଦିଆଯାଇଛି । ସେମାନେ ସମାନ ଭାବରେ ଚାର୍ଜିତ ଅଟନ୍ତି ଏବଂ ପରସ୍ପର ଠାରୁ 0.20 m ଦୂରତାରେ ବିକର୍ଷିତ ହୋଇଛନ୍ତି । ପ୍ରତ୍ୟେକ

ଗୋଲକରେ ଥିବା ଚାର୍ଜର ପରିମାଣ  $\frac{a}{21} \times 10^{-8}$  C ଅଟେ । 'a' ର ମୂଲ୍ୟ ହେବ \_\_\_\_\_ ।

[ଦତ୍ତ :  $g = 10 \text{ ms}^{-2}$ ]

**Response Type :** Numeric

**Evaluation Required For SA :** Yes

**Show Word Count :** Yes

Answers Type : Range

Text Areas : PlainText

Possible Answers :

5 to 5.001

Question Number : 27 Question Id : 70819119500 Question Type : SA

Correct Marks : 4 Wrong Marks : 0

Two identical conducting spheres with negligible volume have 2.1 nC and  $-0.1$  nC charges, respectively. They are brought into contact and then separated by a distance of 0.5 m. The electrostatic force acting between the spheres is \_\_\_\_\_  $\times 10^{-9}$  N.

[Given :  $4\pi\epsilon_0 = \frac{1}{9 \times 10^9}$  SI unit]

Response Type : Numeric

Evaluation Required For SA : Yes

Show Word Count : Yes

Answers Type : Range

Text Areas : PlainText

Possible Answers :

5 to 5.001

Question Number : 27 Question Id : 70819119500 Question Type : SA

Correct Marks : 4 Wrong Marks : 0

ଅଦିନଗଣ୍ୟ ଘନବିଶିଷ୍ଟ ଦୁଇଟି ଏକାଭଳି ପରିବାହୀ ଗୋଲକର ଯଥାକ୍ରମେ 2.1 nC ଏବଂ  $-0.1$  nC ଚାର୍ଜ ରହିଛି । ସେମାନଙ୍କୁ ପରସ୍ପରକୁ ସ୍ପର୍ଶ କରାଗଲା ଏବଂ ଏହାପରେ 0.5 m ଦୂରତାରେ ଅଲଗା ରଖାଗଲା । ଗୋଲକ ଦୁଇଟି ମଧ୍ୟରେ କାର୍ଯ୍ୟକାରୀ ହେଉଥିବା ଛିର ବିଦ୍ୟୁତ୍ ବଳ ହେଉଛି \_\_\_\_\_  $\times 10^{-9}$  N ।

[ଦତ୍ତ :  $4\pi\epsilon_0 = \frac{1}{9 \times 10^9}$  SI ଏକକ]

Response Type : Numeric

Evaluation Required For SA : Yes

Show Word Count : Yes

Answers Type : Range

Text Areas : PlainText

**Possible Answers :**

5 to 5.001

**Question Number : 28 Question Id : 70819119501 Question Type : SA**

**Correct Marks : 4 Wrong Marks : 0**

The peak electric field produced by the radiation coming from the 8 W bulb at a distance of

10 m is  $\frac{x}{10} \sqrt{\frac{\mu_0 c}{\pi}} \frac{V}{m}$ . The efficiency of the bulb is 10% and it is a point source. The value of  $x$  is \_\_\_\_\_.

**Response Type :** Numeric

**Evaluation Required For SA :** Yes

**Show Word Count :** Yes

**Answers Type :** Range

**Text Areas :** PlainText

**Possible Answers :**

5 to 5.001

**Question Number : 28 Question Id : 70819119501 Question Type : SA**

**Correct Marks : 4 Wrong Marks : 0**

10 m ଦୂରତାରେ ଥିବା 8 W ବଲ୍‌ବରୁ ଆସୁଥିବା ବିକିରଣ ଦ୍ୱାରା ସୃଷ୍ଟି ହେଉଥିବା ସର୍ବୋଚ୍ଚ ବୈଦ୍ୟୁତିକ କ୍ଷେତ୍ର  $\frac{x}{10} \sqrt{\frac{\mu_0 c}{\pi}} \frac{V}{m}$  ଅଟେ । ବଲ୍‌ବର ଦକ୍ଷତା 10% ଅଟେ ଏବଂ ଏହା ଗୋଟିଏ ବିନ୍ଦୁ ଉତ୍ସ ।  $x$  ର ମୂଲ୍ୟ ହେଉଛି \_\_\_\_\_ ।

**Response Type :** Numeric

**Evaluation Required For SA :** Yes

**Show Word Count :** Yes

**Answers Type :** Range

**Text Areas :** PlainText

**Possible Answers :**

5 to 5.001

**Question Number : 29 Question Id : 70819119502 Question Type : SA**

**Correct Marks : 4 Wrong Marks : 0**

A current of 6 A enters one corner P of an equilateral triangle PQR having 3 wires of resistance  $2\ \Omega$  each and leaves by the corner R. The currents  $i_1$  in ampere is \_\_\_\_\_ .

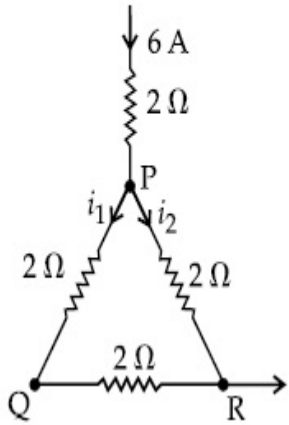

**Response Type :** Numeric

**Evaluation Required For SA :** Yes

**Show Word Count :** Yes

**Answers Type :** Range

**Text Areas :** PlainText

**Possible Answers :**

5 to 5.001

**Question Number : 29 Question Id : 70819119502 Question Type : SA**

**Correct Marks : 4 Wrong Marks : 0**

ପ୍ରତ୍ୟେକ  $2\ \Omega$  ର ବିଦ୍ୟୁତ୍ ପ୍ରତିରୋଧ ଥିବା 3 ଟି ତାର ଯୁକ୍ତ ଏକ ସମବାହୁ ତ୍ରିଭୁଜ PQR ର ଗୋଟିଏ କୋଣ P ଦେଇ 6 A ର ଏକ ବିଦ୍ୟୁତ୍ ସ୍ରୋତ ପ୍ରବେଶ କରୁଛି ଏବଂ R କୋଣ ଦେଇ ବାହାରି ଯାଉଛି । ବିଦ୍ୟୁତ୍ ସ୍ରୋତ  $i_1$  ଯଥାକ୍ରମେ \_\_\_\_\_ ହେବ ।

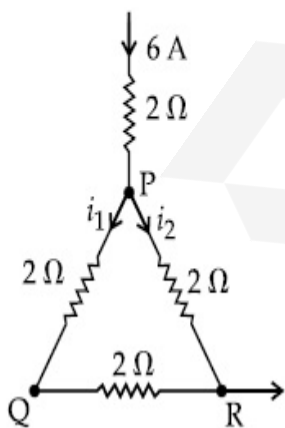

**Response Type :** Numeric

**Evaluation Required For SA :** Yes

Show Word Count : Yes

Answers Type : Range

Text Areas : PlainText

Possible Answers :

5 to 5.001

Question Number : 30 Question Id : 70819119503 Question Type : SA

Correct Marks : 4 Wrong Marks : 0

The wavelength of an X-ray beam is  $10 \text{ \AA}$ . The mass of a fictitious particle having the same energy as that of the X-ray photons is  $\frac{x}{3}h \text{ kg}$ . The value of  $x$  is \_\_\_\_\_.  
( $h$  = Planck's constant)

Response Type : Numeric

Evaluation Required For SA : Yes

Show Word Count : Yes

Answers Type : Range

Text Areas : PlainText

Possible Answers :

5 to 5.001

Question Number : 30 Question Id : 70819119503 Question Type : SA

Correct Marks : 4 Wrong Marks : 0

ଗୋଟିଏ ଏକ୍ସ-ରେ ରଶ୍ମିର ତରଙ୍ଗ ଦୈର୍ଘ୍ୟ  $10 \text{ \AA}$  ଅଟେ । ଏକ୍ସ-ରେ ଫୋଟନ୍ ସହ ଏକା ଶକ୍ତି ଥିବା ଏକ କାଳ୍ପନିକ କଣିକାର ବସ୍ତୁତ୍ୱ  $\frac{x}{3}h \text{ kg}$  ଅଟେ ।  $x$  ର ମୂଲ୍ୟ ହେଉଛି \_\_\_\_\_ ।  
( $h$  = ପ୍ଲାଙ୍କ୍ ଛିରାଙ୍କ)

Response Type : Numeric

Evaluation Required For SA : Yes

Show Word Count : Yes

Answers Type : Range

Text Areas : PlainText

Possible Answers :

5 to 5.001

## Chemistry Section A

Section Id :	708191840
Section Number :	3
Section type :	Online
Mandatory or Optional :	Mandatory
Number of Questions :	20
Number of Questions to be attempted :	20
Section Marks :	80
Mark As Answered Required? :	Yes
Sub-Section Number :	1
Sub-Section Id :	7081911120
Question Shuffling Allowed :	Yes

Question Number : 31 Question Id : 70819119504 Question Type : MCQ Option Shuffling : Yes

Is Question Mandatory : No

Correct Marks : 4 Wrong Marks : 1

Which among the following species has unequal bond lengths ?

Options :

70819163661.  $\text{XeF}_4$

70819163662.  $\text{SiF}_4$

70819163663.  $\text{SF}_4$

70819163664.  $\text{BF}_4^-$

Question Number : 31 Question Id : 70819119504 Question Type : MCQ Option Shuffling : Yes  
Is Question Mandatory : No

Correct Marks : 4 Wrong Marks : 1

ନିମ୍ନଲିଖିତ ପ୍ରଜାତି ମଧ୍ୟରୁ କାହାର ବନ୍ଧର ଦୈର୍ଘ୍ୟ ଅସମାନ ?

Options :

70819163661.  $\text{XeF}_4$

70819163662.  $\text{SiF}_4$

70819163663.  $\text{SF}_4$

70819163664.  $\text{BF}_4^-$

Question Number : 32 Question Id : 70819119505 Question Type : MCQ Option Shuffling : Yes  
Is Question Mandatory : No

Correct Marks : 4 Wrong Marks : 1

The solubility of  $\text{Ca(OH)}_2$  in water is :

[Given : The solubility product of  $\text{Ca(OH)}_2$  in water =  $5.5 \times 10^{-6}$ ]

Options :

70819163665.  $1.11 \times 10^{-2}$

70819163666.  $1.11 \times 10^{-6}$

70819163667.  $1.77 \times 10^{-2}$

70819163668.  $1.77 \times 10^{-6}$

Question Number : 32 Question Id : 70819119505 Question Type : MCQ Option Shuffling : Yes

Is Question Mandatory : No

Correct Marks : 4 Wrong Marks : 1

ଜଳରେ  $\text{Ca}(\text{OH})_2$  ର ଦ୍ରବଣୀୟତା ହେଉଛି,

[ଦତ୍ତ: ଜଳରେ  $\text{Ca}(\text{OH})_2$  ର ଦ୍ରାବ୍ୟତା ଗୁଣଫଳ  $5.5 \times 10^{-6}$ ]

Options :

70819163665.  $1.11 \times 10^{-2}$

70819163666.  $1.11 \times 10^{-6}$

70819163667.  $1.77 \times 10^{-2}$

70819163668.  $1.77 \times 10^{-6}$

Question Number : 33 Question Id : 70819119506 Question Type : MCQ Option Shuffling : Yes

Is Question Mandatory : No

Correct Marks : 4 Wrong Marks : 1

Which one of the following statements is FALSE for hydrophilic sols ?

Options :

70819163669. They do not require electrolytes for stability.

70819163670. These sols are reversible in nature.

70819163671. Their viscosity is of the order of that of  $\text{H}_2\text{O}$ .

70819163672. The sols cannot be easily coagulated.

Question Number : 33 Question Id : 70819119506 Question Type : MCQ Option Shuffling : Yes

Is Question Mandatory : No

Correct Marks : 4 Wrong Marks : 1

ନିମ୍ନୋକ୍ତ କେଉଁ ବିଦ୍ୟୁତି ବିଲୟକାରୀ ପଦାର୍ଥ ପାଇଁ ଭୁଲ ?

Options :

70819163669. ସେମାନେ ସ୍ଥିରତା ପାଇଁ ବିଦ୍ୟୁତ୍ ବିଶ୍ଳେଷଣ ବରକାର କରନ୍ତି ନାହିଁ ।

70819163670. ଏହି ସଲ୍ ଗୁଡ଼ିକ ପ୍ରକୃତିରେ ବିପରୀତମୁଖୀ ।

70819163671. ସେମାନଙ୍କର ଭିସ୍କସିଟି ଜଳର ଭିସ୍କସିଟି ହାର ସହିତ ସମାନ ।

70819163672. ଏହି ସଲ୍ ଗୁଡ଼ିକ ସହଜରେ ଜମାଟାକରଣ କରିହେବ ନାହିଁ ।

Question Number : 34 Question Id : 70819119507 Question Type : MCQ Option Shuffling : Yes

Is Question Mandatory : No

Correct Marks : 4 Wrong Marks : 1

The correct order of bond dissociation enthalpy of halogens is :

Options :

70819163673.  $F_2 > Cl_2 > Br_2 > I_2$

70819163674.  $I_2 > Br_2 > Cl_2 > F_2$

70819163675.  $Cl_2 > Br_2 > F_2 > I_2$

70819163676.  $Cl_2 > F_2 > Br_2 > I_2$

Question Number : 34 Question Id : 70819119507 Question Type : MCQ Option Shuffling : Yes

Is Question Mandatory : No

Correct Marks : 4 Wrong Marks : 1

ହାଲୋଜେନ୍‌ଗୁଡ଼ିକର ବନ୍ଧ ପୃଥକୀକରଣ ଏନ୍ଥାଲପିର ସଠିକ କ୍ରମ ହେଉଛି :

**Options :**

70819163673.  $F_2 > Cl_2 > Br_2 > I_2$

70819163674.  $I_2 > Br_2 > Cl_2 > F_2$

70819163675.  $Cl_2 > Br_2 > F_2 > I_2$

70819163676.  $Cl_2 > F_2 > Br_2 > I_2$

**Question Number : 35 Question Id : 70819119508 Question Type : MCQ Option Shuffling : Yes**

**Is Question Mandatory : No**

**Correct Marks : 4 Wrong Marks : 1**

The method used for the purification of Indium is :

**Options :**

70819163677. van Arkel method

70819163678. liquation

70819163679. zone refining

70819163680. vapour phase refining

**Question Number : 35 Question Id : 70819119508 Question Type : MCQ Option Shuffling : Yes**

**Is Question Mandatory : No**

**Correct Marks : 4 Wrong Marks : 1**

ଇଣ୍ଡିୟମକୁ ସୁଦ୍ଧ କରିବା ନିମନ୍ତେ ବ୍ୟବହୃତ ପ୍ରଣାଳୀ :

**Options :**

70819163677. ଭେନ୍ ଆକ୍ସାଇଡ୍ ପ୍ରଶାଳୀ

70819163678. ଲିକ୍ସେସନ୍

70819163679. କ୍ଷେତ୍ର ସୂଚକ

70819163680. ବାଷ୍ପ ପ୍ରାବଣ୍ଣା ଶୂନ୍ୟତା

Question Number : 36 Question Id : 70819119509 Question Type : MCQ Option Shuffling : Yes

Is Question Mandatory : No

Correct Marks : 4 Wrong Marks : 1

Water does not produce CO on reacting with :

Options :

70819163681.  $\text{CH}_4$

70819163682. C

70819163683.  $\text{CO}_2$

70819163684.  $\text{C}_3\text{H}_8$

Question Number : 36 Question Id : 70819119509 Question Type : MCQ Option Shuffling : Yes

Is Question Mandatory : No

Correct Marks : 4 Wrong Marks : 1

ଜଳ କାହା ସହିତ ପ୍ରତିକ୍ରିୟା କରି CO ଉତ୍ପନ୍ନ କରିପାରେ ନାହିଁ ?

Options :

70819163681.  $\text{CH}_4$

70819163682. C

70819163683. CO<sub>2</sub>

70819163684. C<sub>3</sub>H<sub>8</sub>

**Question Number : 37 Question Id : 70819119510 Question Type : MCQ Option Shuffling : Yes**

**Is Question Mandatory : No**

**Correct Marks : 4 Wrong Marks : 1**

Given below are two statements :

Statement I :

$\alpha$  and  $\beta$  forms of sulphur can change reversibly between themselves with slow heating or slow cooling.

Statement II :

At room temperature the stable crystalline form of sulphur is monoclinic sulphur.

In the light of the above statements, choose the correct answer from the options given below :

**Options :**

70819163685. Both Statement I and Statement II are true.

70819163686. Both Statement I and Statement II are false.

70819163687. Statement I is true but Statement II is false.

70819163688. Statement I is false but Statement II is true.

**Question Number : 37 Question Id : 70819119510 Question Type : MCQ Option Shuffling : Yes**

**Is Question Mandatory : No**

**Correct Marks : 4 Wrong Marks : 1**

ତଳେ ଦୁଇଟି ବିବୃତି ଦିଆଯାଇଛି :

ବିବୃତି I :

ମଞ୍ଚର ଉତ୍ତାପରେ ଅଥବା ମଞ୍ଚର ଥଣ୍ଡା କରିବାରେ  $\alpha$  ଏବଂ  $\beta$  ସଲ୍‌ଫରର ଆକାର ନିଜନିଜ ମଧ୍ୟରେ ଉତ୍କ୍ରମଣୀୟ ଭାବେ ପରିବର୍ତ୍ତନ କରିପାରନ୍ତି ।

ବିବୃତି II :

ପ୍ରକୋଷ୍ଠ ତାପମାତ୍ରାରେ ସଲ୍‌ଫରର ଛିର ସ୍ଫଟିକାକାର ଆକାର ହେଉଛି ମନୋକ୍ଲିନିକ୍ ସଲ୍‌ଫର ।

ଉକ୍ତ ବିବୃତି ଅନୁସାରେ ନିମ୍ନଲିଖିତ ବିକଳ୍ପ ମଧ୍ୟରୁ ସଠିକ୍ ଉତ୍ତରଟିକୁ ବାଛି :

**Options :**

70819163685. ବିବୃତି I ଏବଂ ବିବୃତି II ଉଭୟ ସତ୍ୟ ।

70819163686. ବିବୃତି I ଏବଂ ବିବୃତି II ଉଭୟ ଅସତ୍ୟ

70819163687. ବିବୃତି I ସତ୍ୟ କିନ୍ତୁ ବିବୃତି II ଅସତ୍ୟ

70819163688. ବିବୃତି I ଅସତ୍ୟ କିନ୍ତୁ ବିବୃତି II ସତ୍ୟ

**Question Number : 38 Question Id : 70819119511 Question Type : MCQ Option Shuffling : Yes**

**Is Question Mandatory : No**

**Correct Marks : 4 Wrong Marks : 1**

The major components of German Silver are :

**Options :**

70819163689. Cu, Zn and Ag

70819163690. Cu, Zn and Ni

70819163691. Ge, Cu and Ag

70819163692. Zn, Ni and Ag

Question Number : 38 Question Id : 70819119511 Question Type : MCQ Option Shuffling : Yes

Is Question Mandatory : No

Correct Marks : 4 Wrong Marks : 1

ଜରମାନ ସିଲଭରର ମୁଖ୍ୟ ଉପାଦାନଗୁଡ଼ିକ ହେଉଛି :

Options :

70819163689. Cu, Zn ଏବଂ Ag

70819163690. Cu, Zn ଏବଂ Ni

70819163691. Ge, Cu ଏବଂ Ag

70819163692. Zn, Ni ଏବଂ Ag

Question Number : 39 Question Id : 70819119512 Question Type : MCQ Option Shuffling : Yes

Is Question Mandatory : No

Correct Marks : 4 Wrong Marks : 1

In which of the following order the given complex ions are arranged correctly with respect to their decreasing spin only magnetic moment ?

(i)  $[\text{FeF}_6]^{3-}$  (ii)  $[\text{Co}(\text{NH}_3)_6]^{3+}$  (iii)  $[\text{NiCl}_4]^{2-}$  (iv)  $[\text{Cu}(\text{NH}_3)_4]^{2+}$

Options :

70819163693. (i) > (iii) > (iv) > (ii)

70819163694. (ii) > (iii) > (i) > (iv)

70819163695. (iii) > (iv) > (ii) > (i)

70819163696. (ii) > (i) > (iii) > (iv)

Question Number : 39 Question Id : 70819119512 Question Type : MCQ Option Shuffling : Yes

Is Question Mandatory : No

Correct Marks : 4 Wrong Marks : 1

ନିମ୍ନଲିଖିତ କମ୍ପ୍ଲେକ୍ସ ଆୟନଗୁଡ଼ିକର କେଉଁ ସଠିକ୍ କ୍ରମଟି ହ୍ରାସିତ ସ୍ଥିତି ମାତ୍ର ରୂପକାୟ ଆୟୁର୍ଣ୍ଣ ଅନୁଯାୟୀ ସଜା ହୋଇଛି ?

(i)  $[\text{FeF}_6]^{3-}$  (ii)  $[\text{Co}(\text{NH}_3)_6]^{3+}$  (iii)  $[\text{NiCl}_4]^{2-}$  (iv)  $[\text{Cu}(\text{NH}_3)_4]^{2+}$

Options :

70819163693. (i) > (iii) > (iv) > (ii)

70819163694. (ii) > (iii) > (i) > (iv)

70819163695. (iii) > (iv) > (ii) > (i)

70819163696. (ii) > (i) > (iii) > (iv)

Question Number : 40 Question Id : 70819119513 Question Type : MCQ Option Shuffling : Yes

Is Question Mandatory : No

Correct Marks : 4 Wrong Marks : 1

Given below are two statements :

Statement I :

The pH of rain water is normally ~5.6.

Statement II :

If the pH of rain water drops below 5.6, it is called acid rain.

In the light of the above statements, choose the correct answer from the options given below :

Options :

70819163697. Both Statement I and Statement II are true.

70819163698. Both Statement I and Statement II are false.

70819163699. Statement I is true but Statement II is false.

70819163700. Statement I is false but Statement II is true.

Question Number : 40 Question Id : 70819119513 Question Type : MCQ Option Shuffling : Yes

Is Question Mandatory : No

Correct Marks : 4 Wrong Marks : 1

ନିମ୍ନରେ ଦୁଇଟି ବିବୃତି ଦିଆଯାଇଛି:

ବିବୃତି I :

ବର୍ଷା ଜଳର pH ସାଧାରଣତଃ ~5.6. ।

ବିବୃତି II :

ବର୍ଷା ଜଳର pH 5.6 ରୁ କମ୍ ହେଲେ ଏହାକୁ ଅମ୍ଳ ବର୍ଷା କୁହାଯାଏ ।

ଉପରୋକ୍ତ ବିବୃତି ଅନୁସାରେ ନିମ୍ନଲିଖିତ ବିକଳ୍ପରୁ ସଠିକ୍ ଉତ୍ତର ବାଛି :

Options :

70819163697. ବିବୃତି I ଏବଂ ବିବୃତି II ଉଭୟ ସତ୍ୟ

70819163698. ବିବୃତି I ଏବଂ ବିବୃତି II ଉଭୟ ଅସତ୍ୟ

70819163699. ବିବୃତି I ସତ୍ୟ କିନ୍ତୁ ବିବୃତି II ଅସତ୍ୟ

70819163700. ବିବୃତି I ଅସତ୍ୟ କିନ୍ତୁ ବିବୃତି II ସତ୍ୟ

Question Number : 41 Question Id : 70819119514 Question Type : MCQ Option Shuffling : Yes

Is Question Mandatory : No

Correct Marks : 4 Wrong Marks : 1

Which of the following compound is added to the sodium extract before addition of silver nitrate for testing of halogens ?

Options :

70819163701. Hydrochloric acid

70819163702. Sodium hydroxide

70819163703. Nitric acid

70819163704. Ammonia

Question Number : 41 Question Id : 70819119514 Question Type : MCQ Option Shuffling : Yes

Is Question Mandatory : No

Correct Marks : 4 Wrong Marks : 1

ହାଇଡ୍ରୋଜେନ୍ ପରାକ୍ଷା ନିମନ୍ତେ କେଉଁ ଯୌଗିକକୁ ସିଲିକନ୍ ନାଇଟ୍ରେଟ୍ ମିଶ୍ରଣ ପୂର୍ବରୁ ସୋଡ଼ିୟମ୍ ନିର୍ଯ୍ୟାସରେ ମିଶାଯାଏ ?

Options :

70819163701. ହାଇଡ୍ରୋକ୍ଲୋରିକ୍ ଅମ୍ଳ

70819163702. ସୋଡ଼ିୟମ୍ ହାଇଡ୍ରୋକ୍ସାଇଡ୍

70819163703. ନାଇଟ୍ରିକ୍ ଅମ୍ଳ

70819163704. ଆମୋନିଆ

Question Number : 42 Question Id : 70819119515 Question Type : MCQ Option Shuffling : Yes

Is Question Mandatory : No

Correct Marks : 4 Wrong Marks : 1

The major product of the following reaction is :

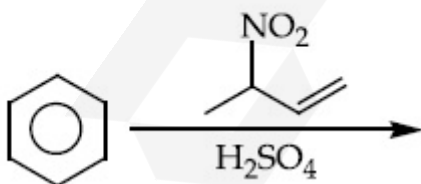

Options :

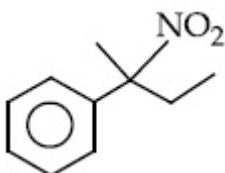

70819163705.

70819163706.

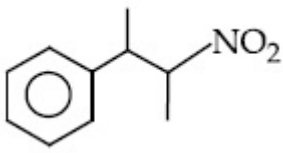

70819163707.

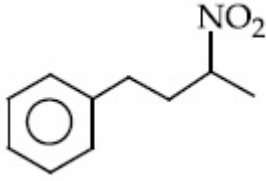

70819163708.

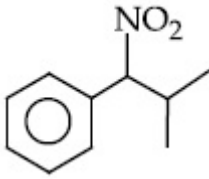

Question Number : 42 Question Id : 70819119515 Question Type : MCQ Option Shuffling : Yes

Is Question Mandatory : No

Correct Marks : 4 Wrong Marks : 1

ନିମ୍ନଲିଖିତ ପ୍ରତିକ୍ରିୟାରେ ମୁଖ୍ୟ ଉତ୍ପାଦଟି ହେଉଛି :

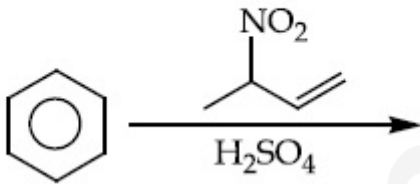

Options :

70819163705.

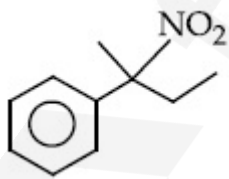

70819163706.

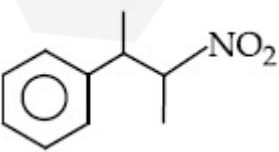

70819163707.

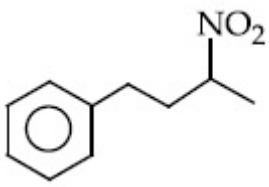

70819163708.

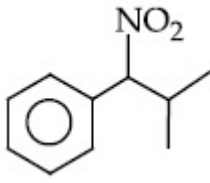

Question Number : 43 Question Id : 70819119516 Question Type : MCQ Option Shuffling : Yes

Is Question Mandatory : No

Correct Marks : 4 Wrong Marks : 1

The major product of the following reaction is :

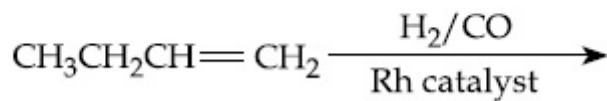

Options :

70819163709.  $\text{CH}_3\text{CH}_2\text{CH}_2\text{CH}_2\text{CHO}$

70819163710.  $\text{CH}_3\text{CH}_2\text{CH}_2\text{CHO}$

70819163711.  $\text{CH}_3\text{CH}_2\text{CH}=\text{CH}-\text{CHO}$

70819163712.  $\begin{array}{c} \text{CH}_3\text{CH}_2\text{C}=\text{CH}_2 \\ | \\ \text{CHO} \end{array}$

Question Number : 43 Question Id : 70819119516 Question Type : MCQ Option Shuffling : Yes

Is Question Mandatory : No

Correct Marks : 4 Wrong Marks : 1

ନିମ୍ନଲିଖିତ ପ୍ରତିକ୍ରିୟାରେ ମୁଖ୍ୟ ଉତ୍ପାଦଟି ହେଉଛି :

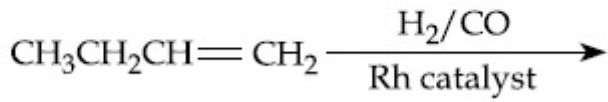

Options :

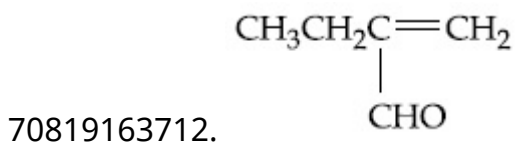
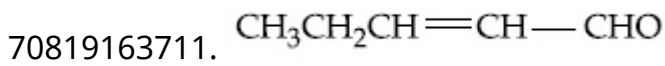
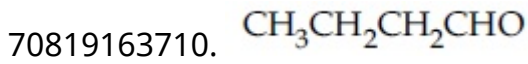
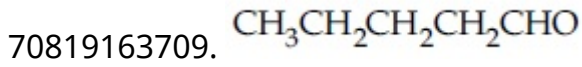

Question Number : 44 Question Id : 70819119517 Question Type : MCQ Option Shuffling : Yes

Is Question Mandatory : No

Correct Marks : 4 Wrong Marks : 1

The correct sequence of reagents used in the preparation of 4-bromo-2-nitroethyl benzene from benzene is :

Options :

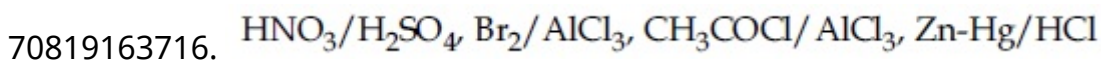
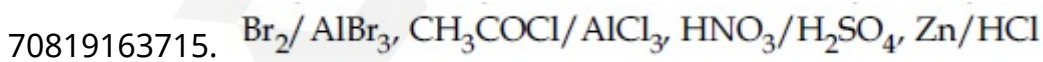
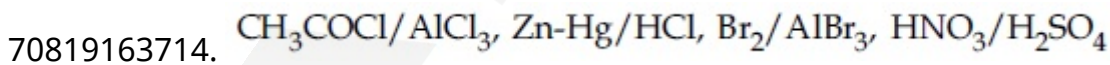
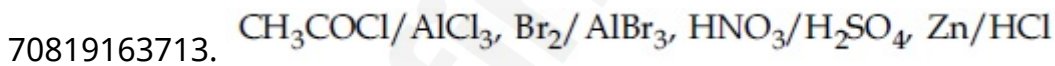

Question Number : 44 Question Id : 70819119517 Question Type : MCQ Option Shuffling : Yes

Is Question Mandatory : No

Correct Marks : 4 Wrong Marks : 1

ବେଞ୍ଜିନ୍‌ରୁ 4-ବ୍ରମୋ-2-ନାଇଟ୍ରୋଇଥାଇଲ୍‌ବେଞ୍ଜିନ୍ ତିଆରି କରିବାରେ ବ୍ୟବହୃତ ଅଭିକର୍ମକର ସଠିକ୍ ଅନୁକ୍ରମଟି ହେଉଛି :

Options :

70819163713.  $\text{CH}_3\text{COCl}/\text{AlCl}_3, \text{Br}_2/\text{AlBr}_3, \text{HNO}_3/\text{H}_2\text{SO}_4, \text{Zn}/\text{HCl}$

70819163714.  $\text{CH}_3\text{COCl}/\text{AlCl}_3, \text{Zn-Hg}/\text{HCl}, \text{Br}_2/\text{AlBr}_3, \text{HNO}_3/\text{H}_2\text{SO}_4$

70819163715.  $\text{Br}_2/\text{AlBr}_3, \text{CH}_3\text{COCl}/\text{AlCl}_3, \text{HNO}_3/\text{H}_2\text{SO}_4, \text{Zn}/\text{HCl}$

70819163716.  $\text{HNO}_3/\text{H}_2\text{SO}_4, \text{Br}_2/\text{AlCl}_3, \text{CH}_3\text{COCl}/\text{AlCl}_3, \text{Zn-Hg}/\text{HCl}$

Question Number : 45 Question Id : 70819119518 Question Type : MCQ Option Shuffling : Yes

Is Question Mandatory : No

Correct Marks : 4 Wrong Marks : 1

The correct order of acid character of the following compounds is :

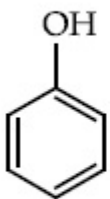

I

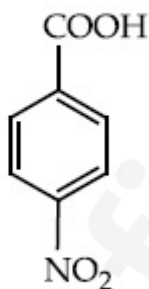

II

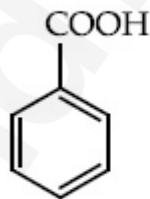

III

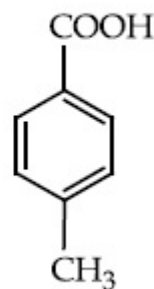

IV

Options :

70819163717.  $\text{I} > \text{II} > \text{III} > \text{IV}$

70819163718.  $\text{III} > \text{II} > \text{I} > \text{IV}$

70819163719.  $\text{II} > \text{III} > \text{IV} > \text{I}$

70819163720.  $\text{IV} > \text{III} > \text{II} > \text{I}$

Question Number : 45 Question Id : 70819119518 Question Type : MCQ Option Shuffling : Yes  
Is Question Mandatory : No

Correct Marks : 4 Wrong Marks : 1

ନିମ୍ନଲିଖିତ ଯୌଗିକ ଗୁଡ଼ିକରେ ଅମ୍ଳଗୁଣର କ୍ରମଟି ହେଉଛି :

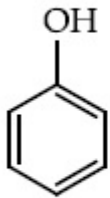

I

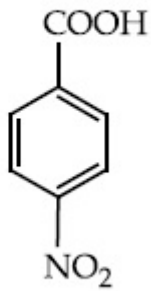

II

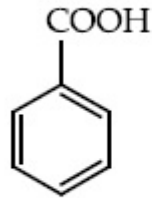

III

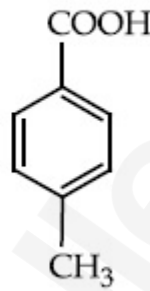

IV

Options :

70819163717. I > II > III > IV

70819163718. III > II > I > IV

70819163719. II > III > IV > I

70819163720. IV > III > II > I

Question Number : 46 Question Id : 70819119519 Question Type : MCQ Option Shuffling : Yes  
Is Question Mandatory : No

Correct Marks : 4 Wrong Marks : 1

What is 'X' in the given reaction ?

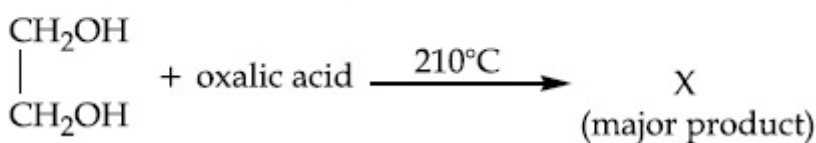

Options :

70819163721.

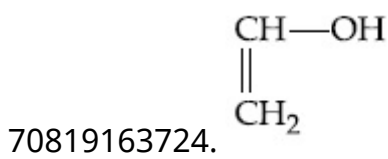
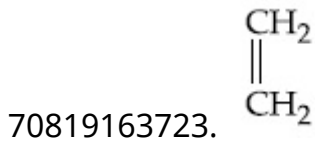
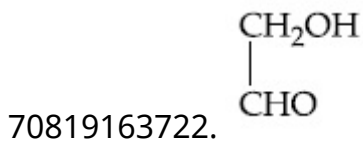
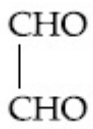

Question Number : 46 Question Id : 70819119519 Question Type : MCQ Option Shuffling : Yes  
Is Question Mandatory : No

Correct Marks : 4 Wrong Marks : 1

ଦତ୍ତ ପ୍ରତିକ୍ରିୟାରେ 'X' କଣ ?

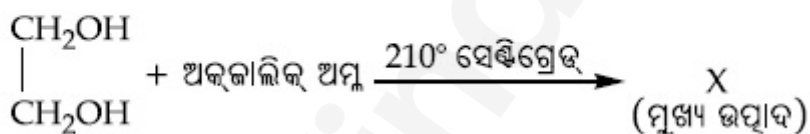

Options :

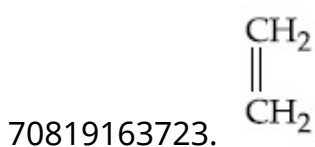
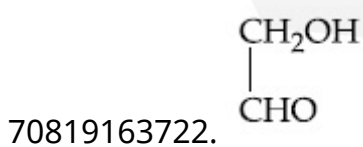
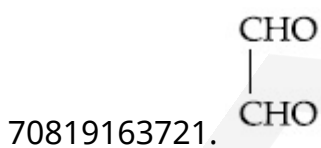

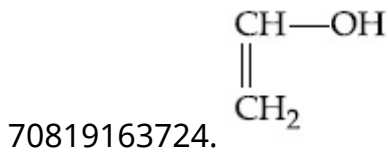

Question Number : 47 Question Id : 70819119520 Question Type : MCQ Option Shuffling : Yes  
Is Question Mandatory : No

Correct Marks : 4 Wrong Marks : 1

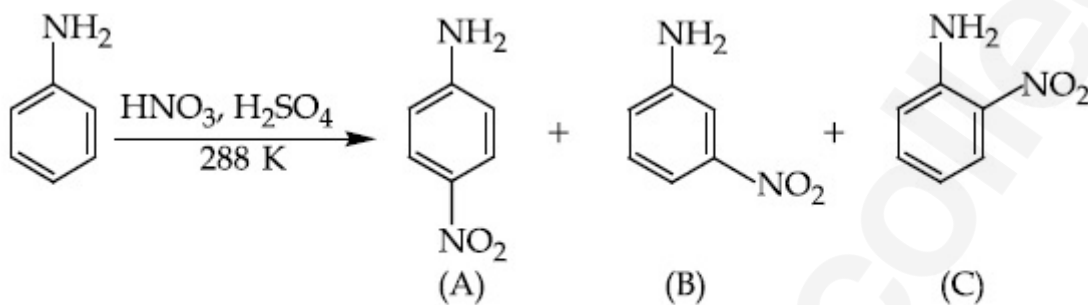

Correct statement about the given chemical reaction is :

Options :

70819163725.  $-\ddot{\text{N}}\text{H}_2$  group is *ortho* and *para* directive, so product (B) is not possible.

70819163726. Reaction is possible and compound (B) will be the major product.

70819163727. The reaction will form sulphonated product instead of nitration.

70819163728. Reaction is possible and compound (A) will be major product.

Question Number : 47 Question Id : 70819119520 Question Type : MCQ Option Shuffling : Yes  
Is Question Mandatory : No

Correct Marks : 4 Wrong Marks : 1

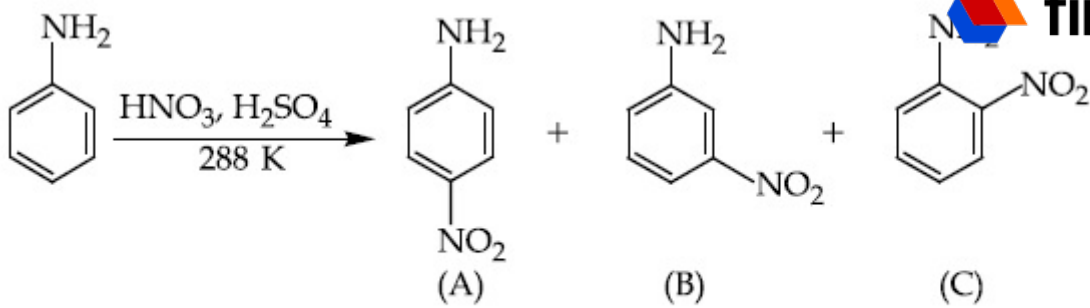

ଦତ୍ତ ପ୍ରତିକ୍ରିୟା ବିଷୟରେ ସଠିକ୍ ବିବୃତିଟି ହେଉଛି :

Options :

70819163725.  $\text{—}\ddot{\text{N}}\text{H}_2$  ଗୁପ୍ ଅର୍ଥୋ ଏବଂ ପାରାଦିଶାସକ । ତେଣୁ ଉତ୍ପାଦ B ସମ୍ଭବ ନୁହେଁ ।

70819163726. ପ୍ରତିକ୍ରିୟାଟି ସମ୍ଭବ ଏବଂ ଯୌଗିକ B ହେଉଛି ମୁଖ୍ୟ ଉତ୍ପାଦ ।

70819163727. ପ୍ରତିକ୍ରିୟାଟି ନାଇଟ୍ରେସନ୍ ପରିବର୍ତ୍ତେ ସଲଫୋନେସନ୍ ଉତ୍ପାଦ ଗଠନ କରିବ ।

70819163728. ପ୍ରତିକ୍ରିୟାଟି ସମ୍ଭବ ଏବଂ ଯୌଗିକ A ମୁଖ୍ୟ ଉତ୍ପାଦ ହେବ ।

Question Number : 48 Question Id : 70819119521 Question Type : MCQ Option Shuffling : Yes

Is Question Mandatory : No

Correct Marks : 4 Wrong Marks : 1

Carbylamine test is used to detect the presence of primary amino group in an organic compound. Which of the following compound is formed when this test is performed with aniline ?

Options :

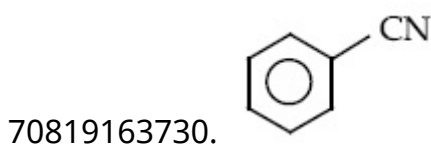
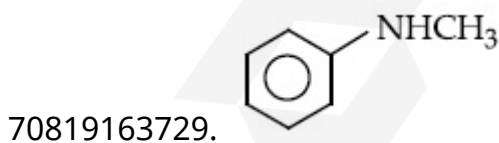

70819163731.

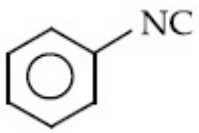

70819163732.

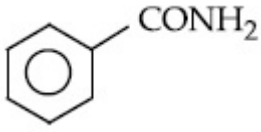

Question Number : 48 Question Id : 70819119521 Question Type : MCQ Option Shuffling : Yes

Is Question Mandatory : No

Correct Marks : 4 Wrong Marks : 1

ଜୈବ ଯୌଗିକରେ ପ୍ରାଇମେରି ଆମିନ୍‌ର ଉପସ୍ଥିତି ଚିହ୍ନଟ କରିବା ପାଇଁ କାରବିଲାମିନ୍ ପରୀକ୍ଷା ବ୍ୟବହୃତ ହୁଏ । ଉକ୍ତ ପରୀକ୍ଷା ଆନିଲିନ୍ ସହିତ ସମ୍ପନ୍ନ କରାଗଲେ ନିମ୍ନଲିଖିତ କେଉଁ ଯୌଗିକଟି ଗଠନ ହୋଇଥାଏ ?

Options :

70819163729.

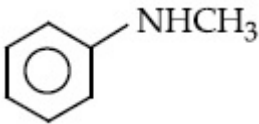

70819163730.

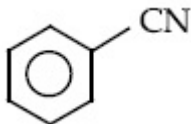

70819163731.

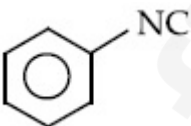

70819163732.



Question Number : 49 Question Id : 70819119522 Question Type : MCQ Option Shuffling : Yes

Is Question Mandatory : No

Correct Marks : 4 Wrong Marks : 1

Which of the following is correct structure of  $\alpha$ -anomer of maltose?  find my college

Options :

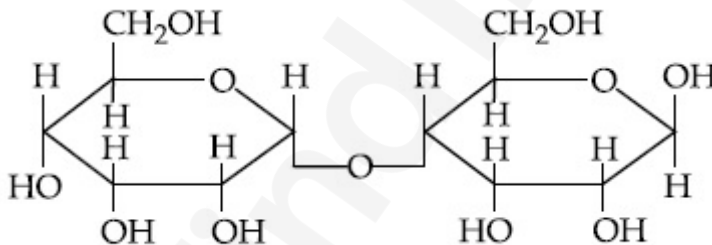
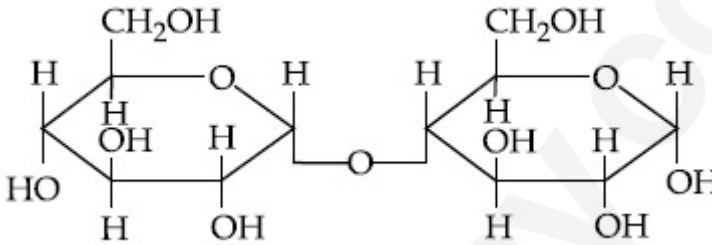
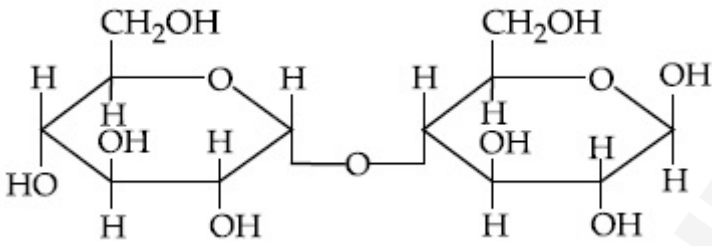
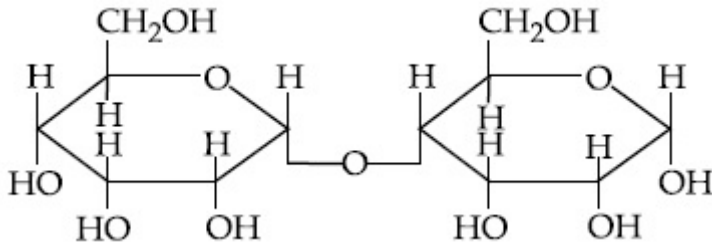

Question Number : 49 Question Id : 70819119522 Question Type : MCQ Option Shuffling : Yes

Is Question Mandatory : No

Correct Marks : 4 Wrong Marks : 1

ନିମ୍ନଲିଖିତ ମଧ୍ୟରୁ କେଉଁଟି ମାଲ୍ଟୋଜର  $\alpha$ - ଆନୋମରର ସଠିକ୍ ସଂରଚନା ?

Options :

70819163733.

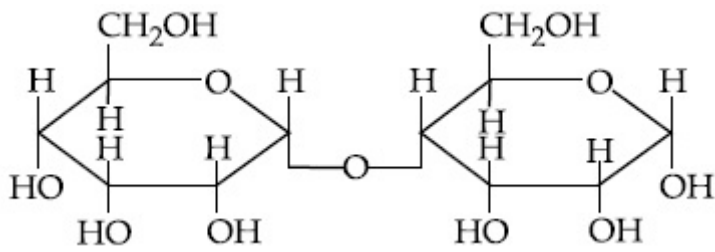

70819163734.

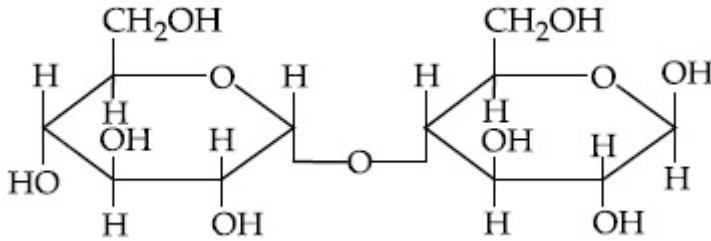

70819163735.

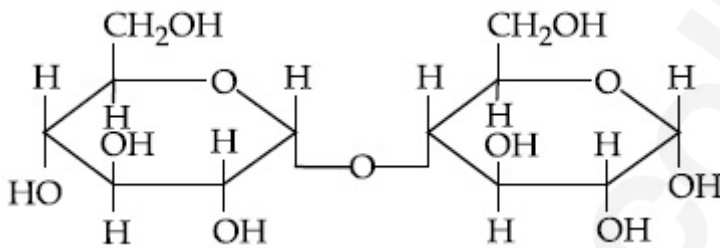

70819163736.

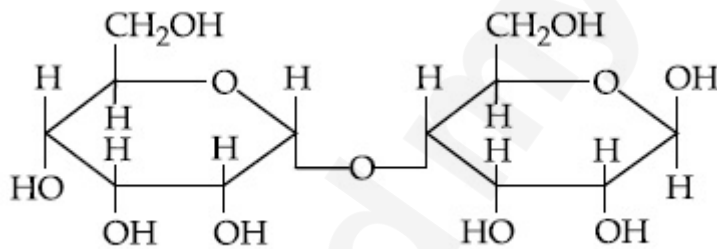

**Question Number : 50 Question Id : 70819119523 Question Type : MCQ Option Shuffling : Yes**

**Is Question Mandatory : No**

**Correct Marks : 4 Wrong Marks : 1**

Given below are two statements :

**Statement I :**

The identification of  $\text{Ni}^{2+}$  is carried out by dimethyl glyoxime in the presence of  $\text{NH}_4\text{OH}$ .

**Statement II :**

The dimethyl glyoxime is a bidentate neutral ligand.

In the light of the above statements, choose the correct answer from the options given below :

**Options :**

70819163737. Both Statement I and Statement II are true.

70819163738. Both Statement I and Statement II are false.

70819163739. Statement I is true but Statement II is false.

70819163740. Statement I is false but Statement II is true.

Question Number : 50 Question Id : 70819119523 Question Type : MCQ Option Shuffling : Yes

Is Question Mandatory : No

Correct Marks : 4 Wrong Marks : 1

ନିମ୍ନରେ ଦୁଇଟି ବିବୃତି ଦିଆଯାଇଛି :

ବିବୃତି I :

ଆମୋନିୟମ୍ ହାଇଡ୍ରୋକ୍ସାଇଡ୍ ଉପସ୍ଥିତିରେ ଡାଇମିଥାଇଲ୍ ଗ୍ଲାଇସିଡ୍ସିମ୍ ଦ୍ୱାରା  $Ni^{2+}$  କୁ ଚିହ୍ନଟ କରାଯାଏ ।

ବିବୃତି II :

ଡାଇମିଥାଇଲ୍ ଗ୍ଲାଇସିଡ୍ସିମ୍ ଏକ ଦ୍ୱି-ଦନ୍ତୀ ନ୍ୟୁଟ୍ରାଲିଟାଣ୍ଟ ।

ଉପରୋକ୍ତ ବିବୃତି ଅନୁସାରେ ନିମ୍ନଲିଖିତ ବିକଳ୍ପରୁ ସଠିକ୍ ଉତ୍ତରଟିକୁ ବାଛି :

Options :

70819163737. ବିବୃତି I ଏବଂ ବିବୃତି II ଉଭୟ ସତ୍ୟ

70819163738. ବିବୃତି I ଏବଂ ବିବୃତି II ଉଭୟ ଅସତ୍ୟ

70819163739. ବିବୃତି I ସତ୍ୟ ଏବଂ ବିବୃତି II ଅସତ୍ୟ

70819163740. ବିବୃତି I ଅସତ୍ୟ ଏବଂ ବିବୃତି II ସତ୍ୟ

## Chemistry Section B

Section Number :	4
Section type :	Online
Mandatory or Optional :	Mandatory
Number of Questions :	10
Number of Questions to be attempted :	5
Section Marks :	20
Mark As Answered Required? :	Yes
Sub-Section Number :	1
Sub-Section Id :	7081911121
Question Shuffling Allowed :	Yes

**Question Number : 51 Question Id : 70819119524 Question Type : SA**

**Correct Marks : 4 Wrong Marks : 0**

Consider titration of NaOH solution versus 1.25 M oxalic acid solution. At the end point following burette readings were obtained.

- |             |             |              |
|-------------|-------------|--------------|
| (i) 4.5 mL  | (ii) 4.5 mL | (iii) 4.4 mL |
| (iv) 4.4 mL | (v) 4.4 mL  |              |

If the volume of oxalic acid taken was 10.0 mL then the molarity of the NaOH solution is \_\_\_\_\_ M. (Rounded-off to the nearest integer)

**Response Type : Numeric**

**Evaluation Required For SA : Yes**

**Show Word Count : Yes**

**Answers Type : Range**

**Text Areas : PlainText**

**Possible Answers :**

5 to 5.001

**Question Number : 51 Question Id : 70819119524 Question Type : SA**

**Correct Marks : 4 Wrong Marks : 0**

NaOH ଦ୍ରବଣ ବନାମ 1.25 M ଅକ୍ଜାଲିକ୍ ଅମ୍ଳ ଅନୁମାପନ ବିଚାର କର ।

ଅନ୍ୟ ବିନ୍ଦୁରେ ନିମ୍ନଲିଖିତ ବ୍ୟାରେଟ୍ ରିଡିଙ୍ଗ୍ ମିଳିଲା ।

(i) 4.5 mL

(ii) 4.5 mL

(iii) 4.4 mL

(iv) 4.4 mL

(v) 4.4 mL

ଯଦି ଅକ୍ଜାଲିକ୍ ଅମ୍ଳ ଆୟତନ 10.0 mL ନିଆଗଲା ତା ହେଲେ NaOH ଦ୍ରବଣର ମୋଲାରିଟି \_\_\_\_\_ M ।

(ନିକଟତମ ପୂର୍ଣ୍ଣ ସଂଖ୍ୟାରେ ପରିଣତ କର)

**Response Type :** Numeric

**Evaluation Required For SA :** Yes

**Show Word Count :** Yes

**Answers Type :** Range

**Text Areas :** PlainText

**Possible Answers :**

5 to 5.001

**Question Number :** 52 **Question Id :** 70819119525 **Question Type :** SA

**Correct Marks :** 4 **Wrong Marks :** 0

The unit cell of copper corresponds to a face centered cube of edge length 3.596 Å with one copper atom at each lattice point. The calculated density of copper in  $\text{kg/m}^3$  is \_\_\_\_\_.

[Molar mass of Cu : 63.54 g ; Avogadro Number =  $6.022 \times 10^{23}$ ]

**Response Type :** Numeric

**Evaluation Required For SA :** Yes

**Show Word Count :** Yes

**Answers Type :** Range

**Text Areas :** PlainText

**Possible Answers :**

5 to 5.001

**Question Number :** 52 **Question Id :** 70819119525 **Question Type :** SA

**Correct Marks :** 4 **Wrong Marks :** 0

କପରର ଯୁନିଟ୍ ସେଲ୍ ଏକ ଫେସ୍ ସେକ୍ଟରଡ୍ କ୍ୟୁବ୍ ସହିତ ଖାପଖାଏ ଯାହାର ଧାରର ଦୈର୍ଘ୍ୟ 3.596 Å ଅଟେ । ଏହାର ପ୍ରତିତ୍ୟକ୍ତ ଲାଟିସ୍ ବିନ୍ଦୁରେ ଏକ କପର ପରମାଣୁ ରହିଥାଏ । କପରର ଗଣନା କରାଯାଇଥିବା ଘନତ୍ୱ  $\text{kg/m}^3$  ରେ ହେଉଛି \_\_\_\_\_ ।

[କପରର ମୋଲାର ବସ୍ତୁତ୍ୱ = 63.54 g

ଆଭୋଗାଡ୍ରୋଙ୍କ ସଂଖ୍ୟା =  $6.022 \times 10^{23}$ ]

**Response Type :** Numeric

**Evaluation Required For SA :** Yes

**Show Word Count :** Yes

**Answers Type :** Range

**Text Areas :** PlainText

**Possible Answers :**

5 to 5.001

**Question Number :** 53 **Question Id :** 70819119526 **Question Type :** SA

**Correct Marks :** 4 **Wrong Marks :** 0

Electromagnetic radiation of wavelength 663 nm is just sufficient to ionise the atom of metal A. The ionization energy of metal A in  $\text{kJ mol}^{-1}$  is \_\_\_\_\_. (Rounded-off to the nearest integer)

[ $h = 6.63 \times 10^{-34} \text{ Js}$ ,  $c = 3.00 \times 10^8 \text{ ms}^{-1}$ ,  $N_A = 6.02 \times 10^{23} \text{ mol}^{-1}$ ]

**Response Type :** Numeric

**Evaluation Required For SA :** Yes

**Show Word Count :** Yes

**Answers Type :** Range

**Text Areas :** PlainText

**Possible Answers :**

5 to 5.001

**Question Number :** 53 **Question Id :** 70819119526 **Question Type :** SA

**Correct Marks :** 4 **Wrong Marks :** 0

ଧାତୁ A ର ପରମାଣୁକୁ ଆୟନୀକରଣ କରିବା ପାଇଁ ଚରଣ ଦୈର୍ଘ୍ୟ 663 nmର ବିଦ୍ୟୁତ୍ ଚୁମ୍ବକୀୟ ବିକିରଣ ଠିକ୍ ଯଥେଷ୍ଟ ହୋଇଥାଏ । ଧାତୁ A ର ଆୟନୀକରଣ ଶକ୍ତି  $\text{kJ mol}^{-1}$  ରେ ହେଉଛି \_\_\_\_\_ । (ନିକଟତମ ପୂର୍ଣ୍ଣ ସଂଖ୍ୟାରେ ପରିଣତ କର)

[ $h = 6.63 \times 10^{-34} \text{ Js}$ ,  $c = 3.00 \times 10^8 \text{ ms}^{-1}$ ,  $N_A = 6.02 \times 10^{23} \text{ mol}^{-1}$ ]

**Response Type :** Numeric

**Evaluation Required For SA :** Yes

**Show Word Count :** Yes

**Answers Type :** Range

**Text Areas :** PlainText

**Possible Answers :**

5 to 5.001

**Question Number : 54 Question Id : 70819119527 Question Type : SA**

**Correct Marks : 4 Wrong Marks : 0**

Five moles of an ideal gas at 293 K is expanded isothermally from an initial pressure of 2.1 MPa to 1.3 MPa against at constant external pressure 4.3 MPa. The heat transferred in this process is \_\_\_\_\_ kJ mol<sup>-1</sup>. (Rounded-off to the nearest integer)

[Use  $R = 8.314 \text{ J mol}^{-1}\text{K}^{-1}$ ]

**Response Type :** Numeric

**Evaluation Required For SA :** Yes

**Show Word Count :** Yes

**Answers Type :** Range

**Text Areas :** PlainText

**Possible Answers :**

5 to 5.001

**Question Number : 54 Question Id : 70819119527 Question Type : SA**

**Correct Marks : 4 Wrong Marks : 0**

293 K ରେ ପାଞ୍ଚ ମୋଲର ଏକ ଆଦର୍ଶ ଗ୍ୟାସ୍ ଆଦ୍ୟତାପ 2.1 MPa ରୁ 1.3 MPa କୁ ଏକ ସ୍ଥିର ବାହ୍ୟ ତାପ 4.3 MPa ବିପକ୍ଷରେ ସମତାପୀୟ ସଂପ୍ରସାରଣ କରିଥାଏ । ଉକ୍ତ ପ୍ରକ୍ରିୟାରେ ହୋଇଥିବା ତାପ ସ୍ଥାନାନ୍ତର ହେଉଛି \_\_\_\_\_ kJ mol<sup>-1</sup> । (ନିକଟତମ ପୂର୍ଣ୍ଣ ସଂଖ୍ୟାରେ ପରିଣତ କର)

[ବ୍ୟବହାର କର  $R = 8.314 \text{ J mol}^{-1}\text{K}^{-1}$ ]

**Response Type :** Numeric

**Evaluation Required For SA :** Yes

**Show Word Count :** Yes

**Answers Type :** Range

**Text Areas :** PlainText

**Possible Answers :**

5 to 5.001

**Question Number : 55 Question Id : 70819119528 Question Type : SA**

**Correct Marks : 4 Wrong Marks : 0**

If a compound AB dissociates to the extent of 75% in an aqueous solution, the molality of the solution which shows a 2.5 K rise in the boiling point of the solution is \_\_\_\_\_ molal.  
(Rounded-off to the nearest integer)

$[K_b = 0.52 \text{ K kg mol}^{-1}]$

**Response Type :** Numeric

**Evaluation Required For SA :** Yes

**Show Word Count :** Yes

**Answers Type :** Range

**Text Areas :** PlainText

**Possible Answers :**

5 to 5.001

**Question Number : 55 Question Id : 70819119528 Question Type : SA**

**Correct Marks : 4 Wrong Marks : 0**

ଯଦି ଜଳୀୟ ଦ୍ରବଣରେ ଏକ ଯୌଗିକ AB 75 ଶତକଡ଼ା ଅଣୁ ପୃଥକୀକରଣ ହୁଏ । 2.5 K ସ୍ଥୂଚନାଙ୍କ ଉନ୍ନତି ଦେଖାଉଥିବା ସେହି ଦ୍ରବଣର ମୋଲାଲିଟି ହେଉଛି \_\_\_\_\_ ମୋଲାଲ୍ । (ନିକଟତମ ପୂର୍ଣ୍ଣ ସଂଖ୍ୟାରେ ପରିଣତ କର)

$[K_b = 0.52 \text{ K kg mol}^{-1}]$

**Response Type :** Numeric

**Evaluation Required For SA :** Yes

**Show Word Count :** Yes

**Answers Type :** Range

**Text Areas :** PlainText

**Possible Answers :**

5 to 5.001

Question Number : 56 Question Id : 70819119529 Question Type : SA

Correct Marks : 4 Wrong Marks : 0

Copper reduces  $\text{NO}_3^-$  into NO and  $\text{NO}_2$  depending upon the concentration of  $\text{HNO}_3$  in solution. (Assuming fixed  $[\text{Cu}^{2+}]$  and  $P_{\text{NO}} = P_{\text{NO}_2}$ ), the  $\text{HNO}_3$  concentration at which the thermodynamic tendency for reduction of  $\text{NO}_3^-$  into NO and  $\text{NO}_2$  by copper is same is  $10^x$  M. The value of  $2x$  is \_\_\_\_\_. (Rounded-off to the nearest integer)

[Given,  $E_{\text{Cu}^{2+}/\text{Cu}}^0 = 0.34$  V,  $E_{\text{NO}_3^-/\text{NO}}^0 = 0.96$  V,  $E_{\text{NO}_3^-/\text{NO}_2}^0 = 0.79$  V and at 298 K,

$$\frac{RT}{F} (2.303) = 0.059]$$

Response Type : Numeric

Evaluation Required For SA : Yes

Show Word Count : Yes

Answers Type : Range

Text Areas : PlainText

Possible Answers :

5 to 5.001

Question Number : 56 Question Id : 70819119529 Question Type : SA

Correct Marks : 4 Wrong Marks : 0

କପର  $\text{NO}_3^-$  କୁ NO ଏବଂ  $\text{NO}_2$  ରେ ବିଜାରଣ କରିବା ପାଇଁ  $\text{HNO}_3$  ଦ୍ରବଣର ସାନ୍ଦ୍ରତା ଉପରେ ନିର୍ଭର କରିଥାଏ ।

(ଧରାଯାଉ  $[\text{Cu}^{2+}]$  ଛିରିକୃତ ଏବଂ  $P_{\text{NO}} = P_{\text{NO}_2}$  ), କପର ଦ୍ୱାରା  $\text{NO}_3^-$  ରୁ NO ଏବଂ  $\text{NO}_2$  ବିଜାରଣ ପାଇଁ

ଅର୍ଥୋତ୍ତମତାକୁ ପ୍ରଦର୍ଶିତ ଦେଖାଉଥିବା  $\text{HNO}_3$  ର ସାନ୍ଦ୍ରତା  $10^x$  M ସହିତ ସମାନ ।  $2x$  ର ମୂଲ୍ୟ ହେଉଛି \_\_\_\_\_ ।

(ନିକଟତମ ପୂର୍ଣ୍ଣ ସଂଖ୍ୟାରେ ପରିଣତ କର)

[ପ୍ରଦତ୍ତ:  $E_{\text{Cu}^{2+}/\text{Cu}}^0 = 0.34$  V,  $E_{\text{NO}_3^-/\text{NO}}^0 = 0.96$  V,  $E_{\text{NO}_3^-/\text{NO}_2}^0 = 0.79$  V and at 298 K,

$$\frac{RT}{F} (2.303) = 0.059]$$

Response Type : Numeric

Evaluation Required For SA : Yes

Show Word Count : Yes

Answers Type : Range

Text Areas : PlainText

**Possible Answers :**

5 to 5.001

**Question Number : 57 Question Id : 70819119530 Question Type : SA**

**Correct Marks : 4 Wrong Marks : 0**

The rate constant of a reaction increases by five times on increase in temperature from 27°C to 52°C. The value of activation energy in  $\text{kJ mol}^{-1}$  is \_\_\_\_\_. (Rounded-off to the nearest integer)

[ $R = 8.314 \text{ J K}^{-1} \text{ mol}^{-1}$ ]

**Response Type : Numeric**

**Evaluation Required For SA : Yes**

**Show Word Count : Yes**

**Answers Type : Range**

**Text Areas : PlainText**

**Possible Answers :**

5 to 5.001

**Question Number : 57 Question Id : 70819119530 Question Type : SA**

**Correct Marks : 4 Wrong Marks : 0**

27°C ରୁ 52°C କୁ ତାପମାତ୍ରା ବୃଦ୍ଧିରେ ଏକ ପ୍ରତିକ୍ରିୟାର ହାର ସ୍ଥିରାଙ୍କ ପାଞ୍ଚ ଗୁଣ ବୃଦ୍ଧି ପାଏ । ସକ୍ରିୟଣ ଶକ୍ତିର ମୂଲ୍ୟ  $\text{kJ mol}^{-1}$  ରେ ହେଉଛି \_\_\_\_\_ ।

(ନିକଟତମ ପୂର୍ଣ୍ଣ ସଂଖ୍ୟାରେ ପରିଣତ କର)

[ $R = 8.314 \text{ J K}^{-1} \text{ mol}^{-1}$ ]

**Response Type : Numeric**

**Evaluation Required For SA : Yes**

**Show Word Count : Yes**

**Answers Type : Range**

**Text Areas : PlainText**

**Possible Answers :**

5 to 5.001

Question Number : 58 Question Id : 70819119531 Question Type : SA

Correct Marks : 4 Wrong Marks : 0

Among the following, number of metal/s which can be used as electrodes in the photoelectric cell is \_\_\_\_\_. (Integer answer)

- (A) Li (B) Na (C) Rb (D) Cs

Response Type : Numeric

Evaluation Required For SA : Yes

Show Word Count : Yes

Answers Type : Range

Text Areas : PlainText

Possible Answers :

5 to 5.001

Question Number : 58 Question Id : 70819119531 Question Type : SA

Correct Marks : 4 Wrong Marks : 0

ନିମ୍ନଲିଖିତ ମଧ୍ୟରୁ ଆଲୋକ ବୈଦ୍ୟୁତିକ କୋଷରେ ଇଲେକ୍ଟ୍ରୋଡ୍ ପରି ବ୍ୟବହୃତ ହେଉଥିବା ଧାତୁର ସଂଖ୍ୟା ହେଉଛି \_\_\_\_\_ । (ପୂର୍ଣ୍ଣସଂଖ୍ୟା ଉତ୍ତର)

- (A) Li (B) Na (C) Rb (D) Cs

Response Type : Numeric

Evaluation Required For SA : Yes

Show Word Count : Yes

Answers Type : Range

Text Areas : PlainText

Possible Answers :

5 to 5.001

Question Number : 59 Question Id : 70819119532 Question Type : SA

Correct Marks : 4 Wrong Marks : 0

The spin only magnetic moment of a divalent ion in aqueous solution (atomic number 29) is \_\_\_\_\_ BM.

Response Type : Numeric

Evaluation Required For SA : Yes

Show Word Count : Yes

Answers Type : Range

Text Areas : PlainText

Possible Answers :

5 to 5.001

Question Number : 59 Question Id : 70819119532 Question Type : SA

Correct Marks : 4 Wrong Marks : 0

ଜଳୀୟ ଦ୍ରବଣରେ ଏକ ଦ୍ଵିଯୋଜୀ ଆୟନର ସ୍ଵିନ୍ ମାତ୍ର ବୃଦ୍ଧି ଆୟତ୍ତ ହେଉଛି \_\_\_\_\_ BM । (ପରମାଣବିକ ସଂଖ୍ୟା 29)

Response Type : Numeric

Evaluation Required For SA : Yes

Show Word Count : Yes

Answers Type : Range

Text Areas : PlainText

Possible Answers :

5 to 5.001

Question Number : 60 Question Id : 70819119533 Question Type : SA

Correct Marks : 4 Wrong Marks : 0

The number of compound/s given below which contain/s —COOH group is \_\_\_\_\_.  
(Integer answer)

- |                      |                   |
|----------------------|-------------------|
| (A) Sulphanilic acid | (B) Picric acid   |
| (C) Aspirin          | (D) Ascorbic acid |

Response Type : Numeric

Evaluation Required For SA : Yes

Show Word Count : Yes

Answers Type : Range

Text Areas : PlainText

Possible Answers :

5 to 5.001

Question Number : 60 Question Id : 70819119533 Question Type : SA

Correct Marks : 4 Wrong Marks : 0

ନିମ୍ନରେ ଦିଆଯାଇଥିବା —COOH group ଥିବା ଯୌଗିକଙ୍କ ସଂଖ୍ୟା ହେଉଛି \_\_\_\_\_ । (ପୂର୍ଣ୍ଣ ସଂଖ୍ୟାରେ ଉତ୍ତର କର)

- (A) ସଲଫୋନିକ୍ ଅମ୍ଳ (B) ପିକ୍ରିକ୍ ଅମ୍ଳ  
(C) ଆସପିରିନ୍ ଅମ୍ଳ (D) ଆସକରବିକ୍ ଅମ୍ଳ

Response Type : Numeric

Evaluation Required For SA : Yes

Show Word Count : Yes

Answers Type : Range

Text Areas : PlainText

Possible Answers :

5 to 5.001

## Mathematics Section A

Section Id :	708191842
Section Number :	5
Section type :	Online
Mandatory or Optional :	Mandatory
Number of Questions :	20
Number of Questions to be attempted :	20
Section Marks :	80
Mark As Answered Required? :	Yes
Sub-Section Number :	1
Sub-Section Id :	7081911122
Question Shuffling Allowed :	Yes

Question Number : 61 Question Id : 70819119534 Question Type : MCQ Option Shuffling : Yes

Is Question Mandatory : No

Correct Marks : 4 Wrong Marks : 1

If for the matrix,  $A = \begin{bmatrix} 1 & -\alpha \\ \alpha & \beta \end{bmatrix}$ ,  $AA^T = I_2$ , then the value of  $\alpha^4 + \beta^4$  is :

Options :

70819163751. 4

70819163752. 1

70819163753. 2

70819163754. 3

Question Number : 61 Question Id : 70819119534 Question Type : MCQ Option Shuffling : Yes

Is Question Mandatory : No

Correct Marks : 4 Wrong Marks : 1

ଯଦି ମାଟ୍ରିକ୍ସ  $A = \begin{bmatrix} 1 & -\alpha \\ \alpha & \beta \end{bmatrix}$  ପାଇଁ,  $AA^T = I_2$ , ତେବେ  $\alpha^4 + \beta^4$  ର ମୂଲ୍ୟ ଅଟେ :

Options :

70819163751. 4

70819163752. 1

70819163753. 2

70819163754. 3

Question Number : 62 Question Id : 70819119535 Question Type : MCQ Option Shuffling : Yes

Is Question Mandatory : No

**Correct Marks : 4 Wrong Marks : 1**

Let A be a  $3 \times 3$  matrix with  $\det(A) = 4$ . Let  $R_i$  denote the  $i^{\text{th}}$  row of A. If a matrix B is obtained by performing the operation  $R_2 \rightarrow 2R_2 + 5R_3$  on  $2A$ , then  $\det(B)$  is equal to :

**Options :**

70819163755. 16

70819163756. 80

70819163757. 64

70819163758. 128

**Question Number : 62 Question Id : 70819119535 Question Type : MCQ Option Shuffling : Yes**

**Is Question Mandatory : No**

**Correct Marks : 4 Wrong Marks : 1**

ମନେକର A ଏକ  $3 \times 3$  ମାଟ୍ରିକ୍ସ ଯାହାର  $\det(A) = 4$  । ମନେକର  $R_i$ , ମାଟ୍ରିକ୍ସ A ର  $i$  ଡିଆଗନାଲ୍ ସୂଚକ କରେ । ଯଦି ମାଟ୍ରିକ୍ସ  $2A$  ଉପରେ  $R_2 \rightarrow 2R_2 + 5R_3$  ରୂପାନ୍ତରଣ ହେତୁ B ମାଟ୍ରିକ୍ସ ମିଳେ, ତେବେ  $\det(B)$  ସମାନ :

**Options :**

70819163755. 16

70819163756. 80

70819163757. 64

70819163758. 128

**Question Number : 63 Question Id : 70819119536 Question Type : MCQ Option Shuffling : Yes**

**Is Question Mandatory : No**

**Correct Marks : 4 Wrong Marks : 1**

The following system of linear equations

$$2x + 3y + 2z = 9$$

$$3x + 2y + 2z = 9$$

$$x - y + 4z = 8$$

**Options :**

70819163759. does not have any solution

70819163760. has a unique solution

70819163761. has infinitely many solutions

70819163762. has a solution  $(\alpha, \beta, \gamma)$  satisfying  $\alpha + \beta^2 + \gamma^3 = 12$

**Question Number : 63 Question Id : 70819119536 Question Type : MCQ Option Shuffling : Yes**

**Is Question Mandatory : No**

**Correct Marks : 4 Wrong Marks : 1**

ନିମ୍ନ ଲିଖିତ ଏକତ୍ରୀୟ ସମୀକରଣ ସମୂହର

$$2x + 3y + 2z = 9$$

$$3x + 2y + 2z = 9$$

$$x - y + 4z = 8$$

**Options :**

70819163759. କୌଣସି ସମାଧାନ ନାହିଁ

70819163760. କେବଳ ମାତ୍ର ଗୋଟିଏ ସମାଧାନ ଅଛି

70819163761. ଅସୀମ ସମାଧାନ ଅଛି

70819163762.  $(\alpha, \beta, \gamma)$  ଗୋଟିଏ ସମାଧାନ ଅଛି ଯେପରିକି  $\alpha + \beta^2 + \gamma^3 = 12$

**Question Number : 64 Question Id : 70819119537 Question Type : MCQ Option Shuffling : Yes**

Is Question Mandatory : No

Correct Marks : 4 Wrong Marks : 1

If  $I_n = \int_{\frac{\pi}{4}}^{\frac{\pi}{2}} \cot^n x \, dx$ , then :

Options :

70819163763.  $\frac{1}{I_2 + I_4}, \frac{1}{I_3 + I_5}, \frac{1}{I_4 + I_6}$  are in A.P.

70819163764.  $I_2 + I_4, I_3 + I_5, I_4 + I_6$  are in A.P.

70819163765.  $\frac{1}{I_2 + I_4}, \frac{1}{I_3 + I_5}, \frac{1}{I_4 + I_6}$  are in G.P.

70819163766.  $I_2 + I_4, (I_3 + I_5)^2, I_4 + I_6$  are in G.P.

Question Number : 64 Question Id : 70819119537 Question Type : MCQ Option Shuffling : Yes

Is Question Mandatory : No

Correct Marks : 4 Wrong Marks : 1

ଯଦି  $I_n = \int_{\frac{\pi}{4}}^{\frac{\pi}{2}} \cot^n x \, dx$ , ତେବେ

Options :

70819163763.  $\frac{1}{I_2 + I_4}, \frac{1}{I_3 + I_5}, \frac{1}{I_4 + I_6}$  ସମାନ୍ତର (ପ୍ରଗତି) ଶ୍ରେଣୀରେ ଅଛନ୍ତି ।

70819163764.  $I_2 + I_4, I_3 + I_5, I_4 + I_6$  ସମାନ୍ତର (ପ୍ରଗତି) ଶ୍ରେଣୀରେ ଅଛନ୍ତି ।

70819163765.  $\frac{1}{I_2 + I_4}, \frac{1}{I_3 + I_5}, \frac{1}{I_4 + I_6}$  ଗୁଣୋତ୍ତର (ପ୍ରଗତି) ଶ୍ରେଣୀରେ ଅଛନ୍ତି ।

70819163766.

$I_2 + I_4, (I_3 + I_5)^2, I_4 + I_6$  ରୁ ଶୋଧର (ପ୍ରଗତି) ଶ୍ରେଣୀରେ ଅ

Question Number : 65 Question Id : 70819119538 Question Type : MCQ Option Shuffling : Yes  
Is Question Mandatory : No

Correct Marks : 4 Wrong Marks : 1

A function  $f(x)$  is given by  $f(x) = \frac{5^x}{5^x + 5}$ , then the sum of the series

$$f\left(\frac{1}{20}\right) + f\left(\frac{2}{20}\right) + f\left(\frac{3}{20}\right) + \dots + f\left(\frac{39}{20}\right)$$

is equal to :

Options :

70819163767.  $\frac{29}{2}$

70819163768.  $\frac{49}{2}$

70819163769.  $\frac{39}{2}$

70819163770.  $\frac{19}{2}$

Question Number : 65 Question Id : 70819119538 Question Type : MCQ Option Shuffling : Yes  
Is Question Mandatory : No

Correct Marks : 4 Wrong Marks : 1

ଗୋଟିଏ ଫଳନ  $f(x)$  କୁ  $f(x) = \frac{5^x}{5^x + 5}$  ଆକାରରେ ଦିଆଯାଇଛି । ତେବେ

$f\left(\frac{1}{20}\right) + f\left(\frac{2}{20}\right) + f\left(\frac{3}{20}\right) + \dots + f\left(\frac{39}{20}\right)$  ଶ୍ରେଣୀର ମିଶାଣ ଫଳ ସମାନ

Options :

70819163767.  $\frac{29}{2}$

70819163768.  $\frac{49}{2}$

70819163769.  $\frac{39}{2}$

70819163770.  $\frac{19}{2}$

Question Number : 66 Question Id : 70819119539 Question Type : MCQ Option Shuffling : Yes

Is Question Mandatory : No

Correct Marks : 4 Wrong Marks : 1

Let  $\alpha$  and  $\beta$  be the roots of  $x^2 - 6x - 2 = 0$ . If  $a_n = \alpha^n - \beta^n$  for  $n \geq 1$ , then the value of  $\frac{a_{10} - 2a_8}{3a_9}$

is :

Options :

70819163771. 4

70819163772. 3

70819163773. 2

70819163774. 1

Question Number : 66 Question Id : 70819119539 Question Type : MCQ Option Shuffling : Yes

Is Question Mandatory : No

Correct Marks : 4 Wrong Marks : 1

ମନେକର  $x^2 - 6x - 2 = 0$  ସମୀକରଣର ବୀଜଗୁଡ଼ିକ  $\alpha$  ଏବଂ  $\beta$  । ଯଦି  $a_n = \alpha^n - \beta^n$ , ( $n \geq 1$ ), ତେବେ  $\frac{a_{10} - 2a_8}{3a_9}$

ର ମୂଲ୍ୟ ଅଟେ :

Options :

70819163771. 4

70819163772. 3

70819163773. 2

70819163774. 1

Question Number : 67 Question Id : 70819119540 Question Type : MCQ Option Shuffling : Yes

Is Question Mandatory : No

Correct Marks : 4 Wrong Marks : 1

The minimum value of  $f(x) = a^{a^x} + a^{1-a^x}$ , where  $a, x \in \mathbb{R}$  and  $a > 0$ , is equal to :

Options :

70819163775.  $a + 1$

70819163776.  $a + \frac{1}{a}$

70819163777.  $2\sqrt{a}$

70819163778.  $2a$

Question Number : 67 Question Id : 70819119540 Question Type : MCQ Option Shuffling : Yes

Is Question Mandatory : No

Correct Marks : 4 Wrong Marks : 1

$f(x) = a^{a^x} + a^{1-a^x}$ , ( $a, x \in \mathbb{R}$  ଏବଂ  $a > 0$ ) ର ସର୍ବାଧିକ ମୂଲ୍ୟ ସମ୍ପାଦନ :

Options :

70819163775.  $a + 1$

70819163776.  $a + \frac{1}{a}$

70819163777.  $2\sqrt{a}$

70819163778.  $2a$

Question Number : 68 Question Id : 70819119541 Question Type : MCQ Option Shuffling : Yes

Is Question Mandatory : No

Correct Marks : 4 Wrong Marks : 1

The integral  $\int \frac{e^{3\log_e 2x} + 5e^{2\log_e 2x}}{e^{4\log_e x} + 5e^{3\log_e x} - 7e^{2\log_e x}} dx$ ,  $x > 0$ , is equal to :

(where  $c$  is a constant of integration)

Options :

70819163779.  $\log_e |x^2 + 5x - 7| + c$

70819163780.  $4\log_e |x^2 + 5x - 7| + c$

70819163781.  $\frac{1}{4} \log_e |x^2 + 5x - 7| + c$

70819163782.  $\log_e \sqrt{x^2 + 5x - 7} + c$

Question Number : 68 Question Id : 70819119541 Question Type : MCQ Option Shuffling : Yes  
Is Question Mandatory : No

Correct Marks : 4 Wrong Marks : 1

ସମାକଳନ  $\int \frac{e^{3\log_e 2x} + 5e^{2\log_e 2x}}{e^{4\log_e x} + 5e^{3\log_e x} - 7e^{2\log_e x}} dx, x > 0$ ; ର ମୂଲ୍ୟ ସମାନ :

(c ସମାକଳନ ସ୍ଥିରାଙ୍କ)

Options :

70819163779.  $\log_e |x^2 + 5x - 7| + c$

70819163780.  $4\log_e |x^2 + 5x - 7| + c$

70819163781.  $\frac{1}{4}\log_e |x^2 + 5x - 7| + c$

70819163782.  $\log_e \sqrt{x^2 + 5x - 7} + c$

Question Number : 69 Question Id : 70819119542 Question Type : MCQ Option Shuffling : Yes  
Is Question Mandatory : No

Correct Marks : 4 Wrong Marks : 1

If  $\alpha, \beta \in \mathbb{R}$  are such that  $1 - 2i$  (here  $i^2 = -1$ ) is a root of  $z^2 + \alpha z + \beta = 0$ , then  $(\alpha - \beta)$  is equal to :

Options :

70819163783. 3

70819163784. -3

70819163785. 7

70819163786. -7

**Question Number : 69 Question Id : 70819119542 Question Type : MCQ Option Shuffling : Yes**

**Is Question Mandatory : No**

**Correct Marks : 4 Wrong Marks : 1**

ଯଦି  $\alpha, \beta \in \mathbf{R}$  ବାସ୍ତବ ସଂଖ୍ୟା ହୁଅନ୍ତି ଯେପରିକି  $1 - 2i, z^2 + \alpha z + \beta = 0$  ର ଗୋଟିଏ ବୀଜ (ମୂଳ) ଅଟେ, ତେବେ  $(\alpha - \beta)$  ସମାନ \_\_\_\_\_ ।  
(ଏଠାରେ  $i^2 = -1$ )

**Options :**

70819163783. 3

70819163784. -3

70819163785. 7

70819163786. -7

**Question Number : 70 Question Id : 70819119543 Question Type : MCQ Option Shuffling : Yes**

**Is Question Mandatory : No**

**Correct Marks : 4 Wrong Marks : 1**

If the curve  $x^2 + 2y^2 = 2$  intersects the line  $x + y = 1$  at two points P and Q, then the angle subtended by the line segment PQ at the origin is :

**Options :**

70819163787.  $\frac{\pi}{2} + \tan^{-1}\left(\frac{1}{4}\right)$

70819163788.

$$\frac{\pi}{2} - \tan^{-1}\left(\frac{1}{4}\right)$$

70819163789.

$$\frac{\pi}{2} + \tan^{-1}\left(\frac{1}{3}\right)$$

70819163790.

$$\frac{\pi}{2} - \tan^{-1}\left(\frac{1}{3}\right)$$

**Question Number : 70 Question Id : 70819119543 Question Type : MCQ Option Shuffling : Yes  
Is Question Mandatory : No**

**Correct Marks : 4 Wrong Marks : 1**

ଯଦି  $x^2 + 2y^2 = 2$  ବକ୍ରରେଖାଟି  $x + y = 1$  ରେଖାଟିକୁ ଦୁଇଟି ବିନ୍ଦୁ P ଓ Q ଠାରେ ଛେଦ କରେ, ତେବେ PQ ରେଖା ଦ୍ୱାରା ମୂଳବିନ୍ଦୁ ଠାରେ ଉତ୍ପନ୍ନ କୋଣଟି ଅଟେ :

**Options :**

$$\frac{\pi}{2} + \tan^{-1}\left(\frac{1}{4}\right)$$

70819163787.

$$\frac{\pi}{2} - \tan^{-1}\left(\frac{1}{4}\right)$$

70819163788.

$$\frac{\pi}{2} + \tan^{-1}\left(\frac{1}{3}\right)$$

70819163789.

$$\frac{\pi}{2} - \tan^{-1}\left(\frac{1}{3}\right)$$

70819163790.

**Question Number : 71 Question Id : 70819119544 Question Type : MCQ Option Shuffling : Yes  
Is Question Mandatory : No**

Correct Marks : 4 Wrong Marks : 1

The shortest distance between the line  $x - y = 1$  and the curve  $x^2 = 2y$  is :

Options :

70819163791.  $\frac{1}{\sqrt{2}}$

70819163792.  $\frac{1}{2\sqrt{2}}$

70819163793. 0

70819163794.  $\frac{1}{2}$

Question Number : 71 Question Id : 70819119544 Question Type : MCQ Option Shuffling : Yes

Is Question Mandatory : No

Correct Marks : 4 Wrong Marks : 1

ରେଖା  $x - y = 1$  ଓ ବକ୍ରରେଖା  $x^2 = 2y$  ମଧ୍ୟରେ ସର୍ବନିମ୍ନ ଦୂରତା ଅଟେ :

Options :

70819163791.  $\frac{1}{\sqrt{2}}$

70819163792.  $\frac{1}{2\sqrt{2}}$

70819163793. 0

70819163794.  $\frac{1}{2}$

Question Number : 72 Question Id : 70819119545 Question Type : MCQ Option Shuffling : Yes

Is Question Mandatory : No

Correct Marks : 4 Wrong Marks : 1

A hyperbola passes through the foci of the ellipse  $\frac{x^2}{25} + \frac{y^2}{16} = 1$  and its transverse and conjugate axes coincide with major and minor axes of the ellipse, respectively. If the product of their eccentricities is one, then the equation of the hyperbola is :

Options :

70819163795.  $\frac{x^2}{9} - \frac{y^2}{16} = 1$

70819163796.  $\frac{x^2}{9} - \frac{y^2}{4} = 1$

70819163797.  $\frac{x^2}{9} - \frac{y^2}{25} = 1$

70819163798.  $x^2 - y^2 = 9$

Question Number : 72 Question Id : 70819119545 Question Type : MCQ Option Shuffling : Yes

Is Question Mandatory : No

Correct Marks : 4 Wrong Marks : 1

$\frac{x^2}{25} + \frac{y^2}{16} = 1$  ଇଲିପ୍ସର ଯୋକତ୍ୱ ଦ୍ୱୟ ମଧ୍ୟ ଦେଇ ଏକ ହାଇପରବୋଲା ଗଠି କରେ ଏବଂ ଏହାର ଟ୍ରାନ୍ସଭରସ୍ ଓ

କଞ୍ଚୁଗେଟ୍ ରେଖା ଦ୍ୱୟ ଯଥାକ୍ରମେ ଇଲିପ୍ସର ମେଜର୍ ଓ ମାଇନର୍ ଅକ୍ସ ସହ ମିଳିଯାଏ । ଯଦି ସେମାନଙ୍କର ଏକତ୍ରୀକୃତ ଦ୍ୱୟର ଗୁଣଫଳ 1 ହୁଏ, ତେବେ ହାଇପରବୋଲାର ସମୀକରଣଟି ଅଟେ :

Options :

70819163795.  $\frac{x^2}{9} - \frac{y^2}{16} = 1$

70819163796.

$$\frac{x^2}{9} - \frac{y^2}{4} = 1$$

70819163797.

$$\frac{x^2}{9} - \frac{y^2}{25} = 1$$

70819163798.

$$x^2 - y^2 = 9$$

Question Number : 73 Question Id : 70819119546 Question Type : MCQ Option Shuffling : Yes

Is Question Mandatory : No

Correct Marks : 4 Wrong Marks : 1

A plane passes through the points A(1, 2, 3), B(2, 3, 1) and C(2, 4, 2). If O is the origin and P is (2, -1, 1), then the projection of  $\vec{OP}$  on this plane is of length :

Options :

70819163799.

$$\sqrt{\frac{2}{3}}$$

70819163800.

$$\sqrt{\frac{2}{11}}$$

70819163801.

$$\sqrt{\frac{2}{7}}$$

70819163802.

$$\sqrt{\frac{2}{5}}$$

Question Number : 73 Question Id : 70819119546 Question Type : MCQ Option Shuffling : Yes

Is Question Mandatory : No

Correct Marks : 4 Wrong Marks : 1

A(1, 2, 3), B(2, 3, 1) ଓ C(2, 4, 2) ବିନ୍ଦୁ ମଧ୍ୟ ଦେଇ ଏକ ସମତଳ ଅତିକ୍ରମ କରେ । ଯଦି O ମୂଳବିନ୍ଦୁ ଓ P (2, -1, 1) ଅନ୍ୟ ଏକ ବିନ୍ଦୁ ହୁଏ, ତେବେ ଉକ୍ତ ସମତଳ ଉପରେ  $\overrightarrow{OP}$  ର ପ୍ରକ୍ଷେପଣର ଦୈର୍ଘ୍ୟ ଅଟେ :

Options :

70819163799.  $\sqrt{\frac{2}{3}}$

70819163800.  $\sqrt{\frac{2}{11}}$

70819163801.  $\sqrt{\frac{2}{7}}$

70819163802.  $\sqrt{\frac{2}{5}}$

Question Number : 74 Question Id : 70819119547 Question Type : MCQ Option Shuffling : Yes

Is Question Mandatory : No

Correct Marks : 4 Wrong Marks : 1

$\lim_{n \rightarrow \infty} \left[ \frac{1}{n} + \frac{n}{(n+1)^2} + \frac{n}{(n+2)^2} + \dots + \frac{n}{(2n-1)^2} \right]$  is equal to :

Options :

70819163803. 1

70819163804.  $\frac{1}{2}$

70819163805.  $\frac{1}{3}$

70819163806.  $\frac{1}{4}$

**Question Number : 74 Question Id : 70819119547 Question Type : MCQ Option Shuffling : Yes**

**Is Question Mandatory : No**

**Correct Marks : 4 Wrong Marks : 1**

$$\lim_{n \rightarrow \infty} \left[ \frac{1}{n} + \frac{n}{(n+1)^2} + \frac{n}{(n+2)^2} + \dots + \frac{n}{(2n-1)^2} \right] \text{ ସମାନ}$$

**Options :**

70819163803.  $1$

70819163804.  $\frac{1}{2}$

70819163805.  $\frac{1}{3}$

70819163806.  $\frac{1}{4}$

**Question Number : 75 Question Id : 70819119548 Question Type : MCQ Option Shuffling : Yes**

**Is Question Mandatory : No**

**Correct Marks : 4 Wrong Marks : 1**

In a group of 400 people, 160 are smokers and non-vegetarian; 100 are smokers and vegetarian and the remaining 140 are non-smokers and vegetarian. Their chances of getting a particular chest disorder are 35%, 20% and 10% respectively. A person is chosen from the group at random and is found to be suffering from the chest disorder. The probability that the selected person is a smoker and non-vegetarian is :

**Options :**

70819163807.  $\frac{7}{45}$

70819163808.  $\frac{8}{45}$

70819163809.  $\frac{28}{45}$

70819163810.  $\frac{14}{45}$

**Question Number : 75 Question Id : 70819119548 Question Type : MCQ Option Shuffling : Yes**

**Is Question Mandatory : No**

**Correct Marks : 4 Wrong Marks : 1**

400 ଲୋକସଂଖ୍ୟା ବିଶିଷ୍ଟ ଏକ ଦଳରେ, 160 ଜଣ ଧୂମ୍ରପାନକାରୀ ଓ ଆମିଷାଶୀ, 100 ଜଣ ଧୂମ୍ରପାନକାରୀ ଓ ନିରାମିଷାଶୀ ଏବଂ ଅବଶିଷ୍ଟ 140 ଜଣ ନିରାମିଷାଶୀ ଓ ଧୂମ୍ରପାନକାରୀ ନୁହନ୍ତି । ସେମାନଙ୍କର ଏକ ନିର୍ଦ୍ଦିଷ୍ଟ ଛାତିରୋଗ ବିଶ୍ୱଜ୍ଞଙ୍କା ହେବାର ସମ୍ଭାବନା ଯଥାକ୍ରମେ 35%, 20% ଓ 10% । ମନେକରାଯାଏ ଯେ ଦଳ ମଧ୍ୟରୁ ଜଣେ ଲୋକକୁ ବଛାଗଲା, ଯେ କି ଛାତି ବିଶ୍ୱଜ୍ଞଙ୍କାରେ ଆକ୍ରାନ୍ତ । ବଛାଯାଇଥିବା ଲୋକ ଜଣଙ୍କ ଧୂମ୍ରପାନକାରୀ ଓ ଆମିଷାଶୀ ହେବାର ସମ୍ଭାବ୍ୟତାଟି ଅଟେ :

**Options :**

70819163807.  $\frac{7}{45}$

70819163808.  $\frac{8}{45}$

70819163809.  $\frac{28}{45}$

70819163810.  $\frac{14}{45}$

**Question Number : 76 Question Id : 70819119549 Question Type : MCQ Option Shuffling : Yes**

**Is Question Mandatory : No**

Correct Marks : 4 Wrong Marks : 1

Let A be a set of all 4-digit natural numbers whose exactly one digit is 7. Then the probability that a randomly chosen element of A leaves remainder 2 when divided by 5 is :

Options :

70819163811.  $\frac{1}{5}$

70819163812.  $\frac{2}{9}$

70819163813.  $\frac{97}{297}$

70819163814.  $\frac{122}{297}$

Question Number : 76 Question Id : 70819119549 Question Type : MCQ Option Shuffling : Yes

Is Question Mandatory : No

Correct Marks : 4 Wrong Marks : 1

ମନେକର A, 4-ଅଙ୍କ ବିଶିଷ୍ଟ ଗଣନ ସଂଖ୍ୟାମାନଙ୍କର ଏକ ସେଟ୍ ଯେଉଁଠି ପ୍ରତ୍ୟେକ ସଂଖ୍ୟାର ଗୋଟିଏ ଅଙ୍କ 0 କି 7 ଅଟେ ।  
ତେବେ ସେଟ୍ A ରୁ ମନରଞ୍ଜା ବଛାଯାଇଥିବା ସଂଖ୍ୟାକୁ 5 ଦ୍ୱାରା ଭାଗ କଲେ, ଭାଗଶେଷ 2 ପାଇବାର ସମ୍ଭାବ୍ୟତା ଅଟେ :

Options :

70819163811.  $\frac{1}{5}$

70819163812.  $\frac{2}{9}$

70819163813.  $\frac{97}{297}$

70819163814.

Question Number : 77 Question Id : 70819119550 Question Type : MCQ Option Shuffling : Yes  
Is Question Mandatory : No

Correct Marks : 4 Wrong Marks : 1

If  $0 < x, y < \pi$  and  $\cos x + \cos y - \cos(x + y) = \frac{3}{2}$ , then  $\sin x + \cos y$  is equal to :

Options :

70819163815.  $\frac{1}{2}$

70819163816.  $\frac{\sqrt{3}}{2}$

70819163817.  $\frac{1 - \sqrt{3}}{2}$

70819163818.  $\frac{1 + \sqrt{3}}{2}$

Question Number : 77 Question Id : 70819119550 Question Type : MCQ Option Shuffling : Yes  
Is Question Mandatory : No

Correct Marks : 4 Wrong Marks : 1

ଯଦି  $0 < x, y < \pi$  ଏବଂ  $\cos x + \cos y - \cos(x + y) = \frac{3}{2}$ , ତେବେ  $\sin x + \cos y$  ସମାନ :

Options :

70819163815.  $\frac{1}{2}$

70819163816.

$$\frac{\sqrt{3}}{2}$$

70819163817.  $\frac{1 - \sqrt{3}}{2}$

70819163818.  $\frac{1 + \sqrt{3}}{2}$

**Question Number : 78 Question Id : 70819119551 Question Type : MCQ Option Shuffling : Yes**

**Is Question Mandatory : No**

**Correct Marks : 4 Wrong Marks : 1**

Let  $x$  denote the total number of one-one functions from a set  $A$  with 3 elements to a set  $B$  with 5 elements and  $y$  denote the total number of one-one functions from the set  $A$  to the set  $A \times B$ . Then :

**Options :**

70819163819.  $2y = 91x$

70819163820.  $2y = 273x$

70819163821.  $y = 91x$

70819163822.  $y = 273x$

**Question Number : 78 Question Id : 70819119551 Question Type : MCQ Option Shuffling : Yes**

**Is Question Mandatory : No**

**Correct Marks : 4 Wrong Marks : 1**

ମନେକର 3 ଉପାଦାନ ବିଶିଷ୍ଟ ସେଟ୍  $A$  ରୁ 5 ଉପାଦାନ ବିଶିଷ୍ଟ ସେଟ୍  $B$  କୁ ମୋଟ  $x$  ଗୋଟି ଏକ-ଏକ ସମ୍ପର୍କ ଅଛି ଓ ସେଟ୍  $A$  ରୁ ସେଟ୍  $A \times B$  କୁ ମୋଟ  $y$  ଗୋଟି ଏକ-ଏକ ସମ୍ପର୍କ ଅଛି । ତେବେ :

Options :

70819163819.  $2y = 91x$

70819163820.  $2y = 273x$

70819163821.  $y = 91x$

70819163822.  $y = 273x$

Question Number : 79 Question Id : 70819119552 Question Type : MCQ Option Shuffling : Yes

Is Question Mandatory : No

Correct Marks : 4 Wrong Marks : 1

$\operatorname{cosec}\left[2\cot^{-1}(5) + \cos^{-1}\left(\frac{4}{5}\right)\right]$  is equal to :

Options :

70819163823.  $\frac{56}{33}$

70819163824.  $\frac{65}{33}$

70819163825.  $\frac{65}{56}$

70819163826.  $\frac{75}{56}$

Question Number : 79 Question Id : 70819119552 Question Type : MCQ Option Shuffling : Yes

Is Question Mandatory : No

Correct Marks : 4 Wrong Marks : 1

$\operatorname{cosec}\left[2\cot^{-1}(5) + \cos^{-1}\left(\frac{4}{5}\right)\right]$  ৰ মান :

Options :

70819163823.  $\frac{56}{33}$

70819163824.  $\frac{65}{33}$

70819163825.  $\frac{65}{56}$

70819163826.  $\frac{75}{56}$

Question Number : 80 Question Id : 70819119553 Question Type : MCQ Option Shuffling : Yes

Is Question Mandatory : No

Correct Marks : 4 Wrong Marks : 1

The contrapositive of the statement "If you will work, you will earn money" is :

Options :

70819163827. To earn money, you need to work

70819163828. You will earn money, if you will not work

70819163829. If you will not earn money, you will not work

70819163830. If you will earn money, you will work

Question Number : 80 Question Id : 70819119553 Question Type : MCQ Option Shuffling : Yes

Is Question Mandatory : No

Correct Marks : 4 Wrong Marks : 1

“ଯଦି ତୁମେ କାମ କରିବ, ତୁମେ ଟଙ୍କା ରୋଜଗାର କରିବ” ଉକ୍ତିଟିର କଣ୍ଠାପଞ୍ଜିଟିର ଉକ୍ତିଟି ଅଟେ :

Options :

70819163827. ଟଙ୍କା ରୋଜଗାର ପାଇଁ, ତୁମେ କାମ କରିବା ଦରକାର

70819163828. ତୁମେ ଟଙ୍କା ରୋଜଗାର କରିବ, ଯଦି ତୁମେ କାମ କରିବ ନାହିଁ

70819163829. ଯଦି ତୁମେ ଟଙ୍କା ରୋଜଗାର କରିବ ନାହିଁ, ତୁମେ କାମ କରିବ ନାହିଁ

70819163830. ଯଦି ତୁମେ ଟଙ୍କା ରୋଜଗାର କରିବ, ତୁମେ କାମ କରିବ

## Mathematics Section B

Section Id :	708191843
Section Number :	6
Section type :	Online
Mandatory or Optional :	Mandatory
Number of Questions :	10
Number of Questions to be attempted :	5
Section Marks :	20
Mark As Answered Required? :	Yes
Sub-Section Number :	1
Sub-Section Id :	7081911123
Question Shuffling Allowed :	Yes

Question Number : 81 Question Id : 70819119554 Question Type : SA

Correct Marks : 4 Wrong Marks : 0

A function  $f$  is defined on  $[-3, 3]$  as

$$f(x) = \begin{cases} \min\{|x|, 2 - x^2\}, & -2 \leq x \leq 2 \\ [|x|] & , 2 < |x| \leq 3 \end{cases}$$

where  $[x]$  denotes the greatest integer  $\leq x$ . The number of points, where  $f$  is not differentiable in  $(-3, 3)$  is \_\_\_\_\_.

**Response Type :** Numeric

**Evaluation Required For SA :** Yes

**Show Word Count :** Yes

**Answers Type :** Range

**Text Areas :** PlainText

**Possible Answers :**

5 to 5.001

**Question Number :** 81 **Question Id :** 70819119554 **Question Type :** SA

**Correct Marks :** 4 **Wrong Marks :** 0

ଫଳନ  $f$  ଟିକୁ  $[-3, 3]$  ଅନ୍ତରାଳରେ ଯଦି ଏପରି ପ୍ରକାଶ କରାଯାଏ

$$f(x) = \begin{cases} \min\{|x|, 2 - x^2\}, & -2 \leq x \leq 2 \\ [|x|] & , 2 < |x| \leq 3 \end{cases}$$

ଯେଉଁଠି  $[x]$  ର ଅର୍ଥ  $\leq x$  ଏକ ପୂର୍ଣ୍ଣସଂଖ୍ୟା ହେବ ଯାହା  $x$  ୦ରୁ ସାନ ବା ସମାନ । ତେବେ  $(-3, 3)$  ଅନ୍ତରାଳରେ ଫଳନ  $f$  ଟି ଅବକଳନୀୟ ନ ହେବାର ବିନ୍ଦୁ ସଂଖ୍ୟା ଅଟେ \_\_\_\_\_ ।

**Response Type :** Numeric

**Evaluation Required For SA :** Yes

**Show Word Count :** Yes

**Answers Type :** Range

**Text Areas :** PlainText

**Possible Answers :**

5 to 5.001

**Question Number :** 82 **Question Id :** 70819119555 **Question Type :** SA

**Correct Marks :** 4 **Wrong Marks :** 0

If the curve,  $y=y(x)$  represented by the solution of the differential equation  $(2xy^2 - y)dx + xdy = 0$ , passes through the intersection of the lines,  $2x - 3y = 1$  and  $3x + 2y = 8$ , then  $|y(1)|$  is equal to \_\_\_\_\_.

**Response Type :** Numeric

**Evaluation Required For SA :** Yes

**Show Word Count :** Yes

**Answers Type :** Range

**Text Areas :** PlainText

**Possible Answers :**

5 to 5.001

**Question Number :** 82 **Question Id :** 70819119555 **Question Type :** SA

**Correct Marks :** 4 **Wrong Marks :** 0

ଯଦି  $y=y(x)$  ବକ୍ରରେଖାଟି,  $(2xy^2 - y)dx + xdy = 0$  ଅବକଳ ସମୀକରଣଟିକୁ ସମାଧାନ କରେ ଓ ରେଖାଦ୍ୱୟ  $2x - 3y = 1$  ଏବଂ  $3x + 2y = 8$  ର ଛେଦ ବିନ୍ଦୁ ମଧ୍ୟ ଦେଇ ଗତି କରେ, ତେବେ  $|y(1)|$  ସମାନ \_\_\_\_\_ ।

**Response Type :** Numeric

**Evaluation Required For SA :** Yes

**Show Word Count :** Yes

**Answers Type :** Range

**Text Areas :** PlainText

**Possible Answers :**

5 to 5.001

**Question Number :** 83 **Question Id :** 70819119556 **Question Type :** SA

**Correct Marks :** 4 **Wrong Marks :** 0

The total number of two digit numbers 'n', such that  $3^n + 7^n$  is a multiple of 10, is \_\_\_\_\_.

**Response Type :** Numeric

**Evaluation Required For SA :** Yes

**Show Word Count :** Yes

**Answers Type :** Range

**Text Areas :** PlainText

Possible Answers :

5 to 5.001

Question Number : 83 Question Id : 70819119556 Question Type : SA

Correct Marks : 4 Wrong Marks : 0

ଦୁଇ ଅଙ୍କ ବିଶିଷ୍ଟ ମୋଟ ସଂଖ୍ୟା 'n', ଯେପରିକି  $3^n + 7^n$ , 10 ର ଏକ ଗୁଣିତକ, ଅଟେ \_\_\_\_\_ ।

Response Type : Numeric

Evaluation Required For SA : Yes

Show Word Count : Yes

Answers Type : Range

Text Areas : PlainText

Possible Answers :

5 to 5.001

Question Number : 84 Question Id : 70819119557 Question Type : SA

Correct Marks : 4 Wrong Marks : 0

If  $\lim_{x \rightarrow 0} \frac{ax - (e^{4x} - 1)}{ax(e^{4x} - 1)}$  exists and is equal to b, then the value of  $a - 2b$  is \_\_\_\_\_.

Response Type : Numeric

Evaluation Required For SA : Yes

Show Word Count : Yes

Answers Type : Range

Text Areas : PlainText

Possible Answers :

5 to 5.001

Question Number : 84 Question Id : 70819119557 Question Type : SA

Correct Marks : 4 Wrong Marks : 0

ଯଦି  $\lim_{x \rightarrow 0} \frac{ax - (e^{4x} - 1)}{ax(e^{4x} - 1)}$  ଚିତ୍ତ୍ୱିତ (ମୂଲ୍ୟ ଅଛି) ଏବଂ ଏହା  $b$  ସଙ୍ଗେ ସମାନ ତେବେ  $a - 2b$  ର ମୂଲ୍ୟ ଅଟେ

\_\_\_\_\_ ।

**Response Type :** Numeric

**Evaluation Required For SA :** Yes

**Show Word Count :** Yes

**Answers Type :** Range

**Text Areas :** PlainText

**Possible Answers :**

5 to 5.001

**Question Number :** 85 **Question Id :** 70819119558 **Question Type :** SA

**Correct Marks :** 4 **Wrong Marks :** 0

If the curves  $x = y^4$  and  $xy = k$  cut at right angles, then  $(4k)^6$  is equal to \_\_\_\_\_.

**Response Type :** Numeric

**Evaluation Required For SA :** Yes

**Show Word Count :** Yes

**Answers Type :** Range

**Text Areas :** PlainText

**Possible Answers :**

5 to 5.001

**Question Number :** 85 **Question Id :** 70819119558 **Question Type :** SA

**Correct Marks :** 4 **Wrong Marks :** 0

ଯଦି ବକ୍ତୃତା ଦ୍ୱୟ  $x = y^4$  ଓ  $xy = k$  ପରସ୍ପରକୁ ସମକୋଣରେ ଛେଦ କରନ୍ତି, ତେବେ  $(4k)^6$  ସମାନ \_\_\_\_\_ ।

**Response Type :** Numeric

**Evaluation Required For SA :** Yes

**Show Word Count :** Yes

**Answers Type :** Range

**Text Areas :** PlainText

Possible Answers :

5 to 5.001

Question Number : 86 Question Id : 70819119559 Question Type : SA

Correct Marks : 4 Wrong Marks : 0

The value of  $\int_{-2}^2 |3x^2 - 3x - 6| dx$  is \_\_\_\_\_.

Response Type : Numeric

Evaluation Required For SA : Yes

Show Word Count : Yes

Answers Type : Range

Text Areas : PlainText

Possible Answers :

5 to 5.001

Question Number : 86 Question Id : 70819119559 Question Type : SA

Correct Marks : 4 Wrong Marks : 0

$\int_{-2}^2 |3x^2 - 3x - 6| dx$  ର ମୂଲ୍ୟ ଅଟେ \_\_\_\_\_ ।

Response Type : Numeric

Evaluation Required For SA : Yes

Show Word Count : Yes

Answers Type : Range

Text Areas : PlainText

Possible Answers :

5 to 5.001

Question Number : 87 Question Id : 70819119560 Question Type : SA

Correct Marks : 4 Wrong Marks : 0

If the remainder when  $x$  is divided by 4 is 3, then the remainder when  $(2020+x)^{100}$  is divided by 8 is \_\_\_\_\_.

**Response Type :** Numeric

**Evaluation Required For SA :** Yes

**Show Word Count :** Yes

**Answers Type :** Range

**Text Areas :** PlainText

**Possible Answers :**

5 to 5.001

**Question Number :** 87 **Question Id :** 70819119560 **Question Type :** SA

**Correct Marks :** 4 **Wrong Marks :** 0

ଯଦି  $x$  କୁ 4 ଦ୍ୱାରା ଭାଗକଲେ ଭାଗଶେଷ 3 ହୁଏ, ତେବେ  $(2020+x)^{2022}$  କୁ 8 ଦ୍ୱାରା ଭାଗ କଲେ, ଭାଗଶେଷ ଅଟେ \_\_\_\_\_ ।

**Response Type :** Numeric

**Evaluation Required For SA :** Yes

**Show Word Count :** Yes

**Answers Type :** Range

**Text Areas :** PlainText

**Possible Answers :**

5 to 5.001

**Question Number :** 88 **Question Id :** 70819119561 **Question Type :** SA

**Correct Marks :** 4 **Wrong Marks :** 0

A line ' $l$ ' passing through origin is perpendicular to the lines

$$l_1 : \vec{r} = (3+t)\hat{i} + (-1+2t)\hat{j} + (4+2t)\hat{k}$$

$$l_2 : \vec{r} = (3+2s)\hat{i} + (3+2s)\hat{j} + (2+s)\hat{k}$$

If the co-ordinates of the point in the first octant on ' $l_2$ ' at a distance of  $\sqrt{17}$  from the point of intersection of ' $l$ ' and ' $l_1$ ' are  $(a, b, c)$ , then  $18(a+b+c)$  is equal to \_\_\_\_\_.

**Response Type :** Numeric

Evaluation Required For SA : Yes

Show Word Count : Yes

Answers Type : Range

Text Areas : PlainText

Possible Answers :

5 to 5.001

Question Number : 88 Question Id : 70819119561 Question Type : SA

Correct Marks : 4 Wrong Marks : 0

ମୂଳବିନ୍ଦୁ ମଧ୍ୟ ଦେଇ ଗଠି କରୁଥିବା ଏକ ରେଖା 'l',

$$l_1 : \vec{r} = (3 + t)\hat{i} + (-1 + 2t)\hat{j} + (4 + 2t)\hat{k}$$

$$l_2 : \vec{r} = (3 + 2s)\hat{i} + (3 + 2s)\hat{j} + (2 + s)\hat{k}$$

$l_1$  ଓ  $l_2$  ପ୍ରତି ଲମ୍ବ ଅଟେ ।

ଯଦି ରେଖା l ଓ  $l_1$  ଦ୍ଵୟର ଛେଦବିନ୍ଦୁ ଠାରୁ  $\sqrt{17}$  ଦୂରରେ ପ୍ରଥମ ପାଦ (ଅକ୍ଷର)ର  $l_2$  ରେଖା ଉପରେ ଅବସ୍ଥିତ ବିନ୍ଦୁର ସ୍ଥାନାଙ୍କ (a, b, c) ହୁଏ ତେବେ  $18(a + b + c)$  ସମାନ \_\_\_\_\_ ।

Response Type : Numeric

Evaluation Required For SA : Yes

Show Word Count : Yes

Answers Type : Range

Text Areas : PlainText

Possible Answers :

5 to 5.001

Question Number : 89 Question Id : 70819119562 Question Type : SA

Correct Marks : 4 Wrong Marks : 0

A line is a common tangent to the circle  $(x - 3)^2 + y^2 = 9$  and the parabola  $y^2 = 4x$ . If the two points of contact (a, b) and (c, d) are distinct and lie in the first quadrant, then  $2(a + c)$  is equal to \_\_\_\_\_.

Response Type : Numeric

Evaluation Required For SA : Yes

Show Word Count : Yes

Answers Type : Range

Text Areas : PlainText

Possible Answers :

5 to 5.001

Question Number : 89 Question Id : 70819119562 Question Type : SA

Correct Marks : 4 Wrong Marks : 0

ଗୋଟିଏ ରେଖା  $(x-3)^2 + y^2 = 9$  ବୃତ୍ତ ଓ  $y^2 = 4x$  ପାରାବୋଲାର ସାଧାରଣ ସ୍ପର୍ଶକ ଅଟେ । ଯଦି ଦୁଇଟି ପୃଥକ୍ ସ୍ପର୍ଶବିନ୍ଦୁ  $(a, b)$  ଓ  $(c, d)$  ପ୍ରଥମ ପାଦରେ ଅବସ୍ଥାନ କରନ୍ତି, ତେବେ  $2(a+c)$  ସମାନ \_\_\_\_\_ ।

Response Type : Numeric

Evaluation Required For SA : Yes

Show Word Count : Yes

Answers Type : Range

Text Areas : PlainText

Possible Answers :

5 to 5.001

Question Number : 90 Question Id : 70819119563 Question Type : SA

Correct Marks : 4 Wrong Marks : 0

Let  $\vec{a} = \hat{i} + \alpha\hat{j} + 3\hat{k}$  and  $\vec{b} = 3\hat{i} - \alpha\hat{j} + \hat{k}$ . If the area of the parallelogram whose adjacent sides are represented by the vectors  $\vec{a}$  and  $\vec{b}$  is  $8\sqrt{3}$  square units, then  $\vec{a} \cdot \vec{b}$  is equal to \_\_\_\_\_.

Response Type : Numeric

Evaluation Required For SA : Yes

Show Word Count : Yes

Answers Type : Range

Text Areas : PlainText

Possible Answers :

Question Number : 90 Question Id : 70819119563 Question Type : SA

Correct Marks : 4 Wrong Marks : 0

ମନେକର  $\vec{a} = \hat{i} + \alpha\hat{j} + 3\hat{k}$  ଏବଂ  $\vec{b} = 3\hat{i} - \alpha\hat{j} + \hat{k}$ . ଯଦି  $\vec{a}$  ଓ  $\vec{b}$  ସଂଲଗ୍ନ ବାହୁଥିବା ସାମନ୍ତରିକ କ୍ଷେତ୍ରର

କ୍ଷେତ୍ରଫଳ  $8\sqrt{3}$  ବର୍ଗ ଏକକ ହୁଏ, ତେବେ  $\vec{a} \cdot \vec{b}$  ସମାନ \_\_\_\_\_ ।

Response Type : Numeric

Evaluation Required For SA : Yes

Show Word Count : Yes

Answers Type : Range

Text Areas : PlainText

Possible Answers :