

National Testing Agency

Question Paper Name :	BTECH E 5th Sep 2020 Shift 2
Subject Name :	BTECH E
Creation Date :	2020-09-05 21:22:15
Duration :	180
Total Marks :	300
Display Marks:	Yes
Share Answer Key With Delivery Engine :	Yes
Actual Answer Key :	Yes

BTECH

Group Number :	1
Group Id :	405036131
Group Maximum Duration :	0
Group Minimum Duration :	180
Show Attended Group? :	No
Edit Attended Group? :	No
Break time :	0
Group Marks :	300
Is this Group for Examiner? :	No

Physics

Section Id :	405036433
Section Number :	1
Section type :	Online
Mandatory or Optional :	Mandatory
Number of Questions :	25
Number of Questions to be attempted :	25
Section Marks :	100
Display Number Panel :	Yes
Group All Questions :	Yes
Mark As Answered Required? :	Yes
Sub-Section Number :	1
Sub-Section Id :	405036833
Question Shuffling Allowed :	Yes

Question Number : 1 Question Id : 40503611831 Question Type : MCQ Option Shuffling : Yes Display Question Number : Yes Is Question Mandatory : No Single Line Question Option : No Option

Orientation : Vertical

Correct Marks : 4 Wrong Marks : 1

The quantities $x = \frac{1}{\sqrt{\mu_0 \epsilon_0}}$, $y = \frac{E}{B}$ and

$z = \frac{l}{CR}$ are defined where C-capacitance,

R-Resistance, l -length, E-Electric field, B-magnetic field and ϵ_0 , μ_0 - free space permittivity and permeability respectively.

Then :

Options :

40503642816. Only x and y have the same dimension.

40503642817. Only y and z have the same dimension.

40503642818. Only x and z have the same dimension.

40503642819. x , y and z have the same dimension.

Question Number : 1 Question Id : 40503611831 Question Type : MCQ Option Shuffling : Yes Display

Question Number : Yes Is Question Mandatory : No Single Line Question Option : No Option

Orientation : Vertical

Correct Marks : 4 Wrong Marks : 1

यदि राशियाँ x , y , z की परिभाषायें $x = \frac{1}{\sqrt{\mu_0 \epsilon_0}}$,

$y = \frac{E}{B}$ और $z = \frac{l}{CR}$ है जहाँ C-धारिता, R-प्रतिरोध,

l -लम्बाई, E-वैद्युत क्षेत्र, B-चुम्बकीय क्षेत्र और ϵ_0 , μ_0 -निर्वात की विद्युतशीलता एवं चुम्बकीयशीलता, क्रमशः है। तो :

Options :

40503642816. केवल x तथा y की समान विमायें हैं।

40503642817. केवल y तथा z की समान विमायें हैं।

40503642818. केवल x तथा z की समान विमायें हैं।

40503642819. x, y तथा z की समान विमायें हैं।

Question Number : 2 Question Id : 40503611832 Question Type : MCQ Option Shuffling : Yes Display Question Number : Yes Is Question Mandatory : No Single Line Question Option : No Option Orientation : Vertical

Correct Marks : 4 Wrong Marks : 1

The velocity (v) and time (t) graph of a body in a straight line motion is shown in the figure. The point S is at 4.333 seconds. The total distance covered by the body in 6 s is :

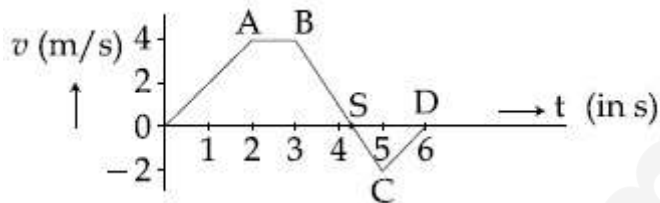

Options :

40503642820. $\frac{37}{3}$ m

40503642821. 11 m

40503642822. $\frac{49}{4}$ m

40503642823. 12 m

Question Number : 2 Question Id : 40503611832 Question Type : MCQ Option Shuffling : Yes Display Question Number : Yes Is Question Mandatory : No Single Line Question Option : No Option Orientation : Vertical

Correct Marks : 4 Wrong Marks : 1

सरल रेखा में गतिशील एक पिण्ड का समय (t) के साथ वेग (v) को दिये गये ग्राफ में दर्शाया गया है। बिन्दु S, 4.333 सैकण्ड पर हैं। पिण्ड द्वारा 6 s में तय की गयी कुल दूरी होगी :

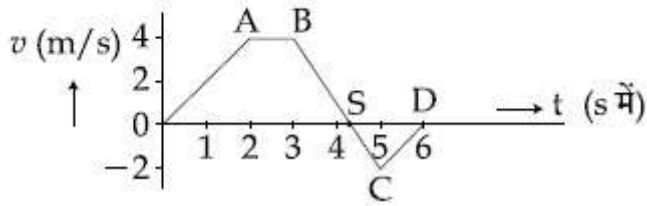

Options :

40503642820. $\frac{37}{3}$ m

40503642821. 11 m

40503642822. $\frac{49}{4}$ m

40503642823. 12 m

Question Number : 3 Question Id : 40503611833 Question Type : MCQ Option Shuffling : Yes Display Question Number : Yes Is Question Mandatory : No Single Line Question Option : No Option Orientation : Vertical

Correct Marks : 4 Wrong Marks : 1

A spaceship in space sweeps stationary interplanetary dust. As a result, its mass

increases at a rate $\frac{dM(t)}{dt} = bv^2(t)$, where

$v(t)$ is its instantaneous velocity. The instantaneous acceleration of the satellite is:

Options :

40503642824. $-\frac{2bv^3}{M(t)}$

40503642825. $-\frac{bv^3}{M(t)}$

40503642826. $-\frac{bv^3}{2M(t)}$

40503642827. $-bv^3(t)$

Question Number : 3 Question Id : 40503611833 Question Type : MCQ Option Shuffling : Yes Display Question Number : Yes Is Question Mandatory : No Single Line Question Option : No Option Orientation : Vertical

Correct Marks : 4 Wrong Marks : 1

अंतरिक्ष में एक अंतरिक्ष यान, ग्रहों के बीच की धूल एकत्रित करते हुए चलता है। परिणामस्वरूप उसके द्रव्यमान के बढ़ने की दर $\frac{dM(t)}{dt} = bv^2(t)$ है। जहाँ $v(t)$ तात्क्षणिक वेग है। अंतरिक्ष यान का तात्क्षणिक त्वरण है :

Options :

40503642824. $-\frac{2bv^3}{M(t)}$

40503642825. $-\frac{bv^3}{M(t)}$

40503642826. $-\frac{bv^3}{2M(t)}$

40503642827. $-bv^3(t)$

Question Number : 4 Question Id : 40503611834 Question Type : MCQ Option Shuffling : Yes Display Question Number : Yes Is Question Mandatory : No Single Line Question Option : No Option Orientation : Vertical

Correct Marks : 4 Wrong Marks : 1

A ring is hung on a nail. It can oscillate, without slipping or sliding (i) in its plane with a time period T_1 and, (ii) back and forth in a direction perpendicular to its plane, with a period T_2 . The ratio $\frac{T_1}{T_2}$ will

be :

Options :

40503642828. $\frac{2}{3}$

40503642829. $\frac{\sqrt{2}}{3}$

40503642830. $\frac{2}{\sqrt{3}}$

40503642831. $\frac{3}{\sqrt{2}}$

Question Number : 4 Question Id : 40503611834 Question Type : MCQ Option Shuffling : Yes Display Question Number : Yes Is Question Mandatory : No Single Line Question Option : No Option Orientation : Vertical

Correct Marks : 4 Wrong Marks : 1

एक छल्ला एक कील पर टंगा हुआ है। वह (i) अपने समतल में बिना सरके या फिसले T_1 आवर्तकाल से दोलन कर सकता है और (ii) अपने समतल के लम्बवत दिशा में T_2 आवर्तकाल से आगे-पीछे दोलन कर सकता है। अनुपात $\frac{T_1}{T_2}$ होगा :

Options :

40503642828. $\frac{2}{3}$

40503642829. $\frac{\sqrt{2}}{3}$

40503642830. $\frac{2}{\sqrt{3}}$

40503642831. $\frac{3}{\sqrt{2}}$

Question Number : 5 Question Id : 40503611835 Question Type : MCQ Option Shuffling : Yes Display Question Number : Yes Is Question Mandatory : No Single Line Question Option : No Option Orientation : Vertical

Correct Marks : 4 Wrong Marks : 1

The acceleration due to gravity on the earth's surface at the poles is g and angular velocity of the earth about the axis passing through the pole is ω . An object is weighed at the equator and at a height h above the poles by using a spring balance. If the weights are found to be same, then h is : ($h \ll R$, where R is the radius of the earth)

Options :

40503642832. $\frac{R^2 \omega^2}{g}$

40503642833. $\frac{R^2 \omega^2}{4g}$

40503642834. $\frac{R^2 \omega^2}{8g}$

40503642835. $\frac{R^2 \omega^2}{2g}$

Question Number : 5 Question Id : 40503611835 Question Type : MCQ Option Shuffling : Yes Display Question Number : Yes Is Question Mandatory : No Single Line Question Option : No Option Orientation : Vertical

Correct Marks : 4 Wrong Marks : 1

पृथ्वी की सतह के ध्रुवों पर गुरुत्वीय त्वरण 'g' है तथा ध्रुवों से जाने वाली अक्ष के सापेक्ष पृथ्वी की कोणीय चाल 'ω' है। एक वस्तु का भार भूमध्य रेखा पर तथा ध्रुवों से 'h' ऊँचाई पर एक कमानीदार तुला द्वारा नापा गया। यदि दोनों भारों का मान बराबर पाया जाता है, तब ऊँचाई h का मान होगा : ($h \ll R$, जहाँ R पृथ्वी की त्रिज्या है)

Options :

40503642832. $\frac{R^2 \omega^2}{g}$

40503642833. $\frac{R^2 \omega^2}{4g}$

40503642834. $\frac{R^2 \omega^2}{8g}$

40503642835. $\frac{R^2 \omega^2}{2g}$

Question Number : 6 Question Id : 40503611836 Question Type : MCQ Option Shuffling : Yes Display Question Number : Yes Is Question Mandatory : No Single Line Question Option : No Option Orientation : Vertical

Correct Marks : 4 Wrong Marks : 1

Two different wires having lengths L_1 and L_2 , and respective temperature coefficient of linear expansion α_1 and α_2 , are joined end-to-end. Then the effective temperature coefficient of linear expansion is :

Options :

40503642836. $4 \frac{\alpha_1 \alpha_2}{\alpha_1 + \alpha_2} \frac{L_2 L_1}{(L_2 + L_1)^2}$

40503642837. $\frac{\alpha_1 + \alpha_2}{2}$

$$\frac{\alpha_1 L_1 + \alpha_2 L_2}{L_1 + L_2}$$

40503642838.

$$2\sqrt{\alpha_1 \alpha_2}$$

40503642839.

Question Number : 6 Question Id : 40503611836 Question Type : MCQ Option Shuffling : Yes Display Question Number : Yes Is Question Mandatory : No Single Line Question Option : No Option Orientation : Vertical

Correct Marks : 4 Wrong Marks : 1

दो अलग तारों की लम्बाइयाँ L_1 तथा L_2 हैं एवं उनके रेखीय ताप प्रसार गुणांक, क्रमशः, α_1 तथा α_2 हैं। यदि उन तारों के सिरों को जोड़ा जाये तो प्रभावी रेखीय प्रसार ताप गुणांक होगा :

Options :

$$4 \frac{\alpha_1 \alpha_2}{\alpha_1 + \alpha_2} \frac{L_2 L_1}{(L_2 + L_1)^2}$$

40503642836.

$$\frac{\alpha_1 + \alpha_2}{2}$$

40503642837.

$$\frac{\alpha_1 L_1 + \alpha_2 L_2}{L_1 + L_2}$$

40503642838.

$$2\sqrt{\alpha_1 \alpha_2}$$

40503642839.

Question Number : 7 Question Id : 40503611837 Question Type : MCQ Option Shuffling : Yes Display Question Number : Yes Is Question Mandatory : No Single Line Question Option : No Option Orientation : Vertical

Correct Marks : 4 Wrong Marks : 1

In an experiment to verify Stokes law, a small spherical ball of radius r and density ρ falls under gravity through a distance h in air before entering a tank of water. If the terminal velocity of the ball inside water is same as its velocity just before entering the water surface, then the value of h is proportional to :

(ignore viscosity of air)

Options :

40503642840. r

40503642841. r^2

40503642842. r^3

40503642843. r^4

Question Number : 7 Question Id : 40503611837 Question Type : MCQ Option Shuffling : Yes Display Question Number : Yes Is Question Mandatory : No Single Line Question Option : No Option Orientation : Vertical

Correct Marks : 4 Wrong Marks : 1

स्टोक्स नियम प्रमाणित करने के लिए एक परीक्षण में एक छोटी गोली जिसकी त्रिज्या r एवं घनत्व ρ है, एक पानी से भरी टंकी की सतह से h ऊँचाई से गुरुत्वीय क्षेत्र के अंतर्गत गिरायी जाती है। यदि गोली का पानी में घुसने से तुरंत पहले पानी के अंदर सीमांत वेग पानी में वेग के बराबर हो तो h, r पर इस प्रकार समानुपाती है : (वायु की श्यानता नगण्य लें)

Options :

40503642840. r

40503642841. r^2

40503642842. r^3

40503642843. r^4

Question Number : 8 Question Id : 40503611838 Question Type : MCQ Option Shuffling : Yes Display Question Number : Yes Is Question Mandatory : No Single Line Question Option : No Option Orientation : Vertical

Correct Marks : 4 Wrong Marks : 1

In an adiabatic process, the density of a diatomic gas becomes 32 times its initial value. The final pressure of the gas is found to be n times the initial pressure. The value of n is :

Options :

40503642844. 128

40503642845. $\frac{1}{32}$

40503642846. 32

40503642847. 326

Question Number : 8 Question Id : 40503611838 Question Type : MCQ Option Shuffling : Yes Display Question Number : Yes Is Question Mandatory : No Single Line Question Option : No Option Orientation : Vertical

Correct Marks : 4 Wrong Marks : 1

किसी रुद्धोष्म प्रक्रिया में एक द्विपरमाणुक गैस का घनत्व पहले का 32 गुना हो जाता है। प्रक्रिया के अंत में गैस का दबाव उसके शुरू के दबाव से n गुना पाया जाता है। n का मान होगा :

Options :

40503642844. 128

40503642845. $\frac{1}{32}$

40503642846. 32

40503642847. 326

Question Number : 9 Question Id : 40503611839 Question Type : MCQ Option Shuffling : Yes Display
Question Number : Yes Is Question Mandatory : No Single Line Question Option : No Option
Orientation : Vertical

Correct Marks : 4 Wrong Marks : 1

A driver in a car, approaching a vertical wall notices that the frequency of his car horn, has changed from 440 Hz to 480 Hz, when it gets reflected from the wall. If the speed of sound in air is 345 m/s, then the speed of the car is :

Options :

40503642848. 54 km/hr

40503642849. 36 km/hr

40503642850. 24 km/hr

40503642851. 18 km/hr

Question Number : 9 Question Id : 40503611839 Question Type : MCQ Option Shuffling : Yes Display
Question Number : Yes Is Question Mandatory : No Single Line Question Option : No Option
Orientation : Vertical

Correct Marks : 4 Wrong Marks : 1

एक कार एक दीवार की तरफ जा रही है। उसके अन्दर बैठा चालक नोटिस करता है कि हार्न की ध्वनि जब दीवार से टकराकर वापस आती है तो उसकी आवृत्ति 440 Hz से बदलकर 480 Hz हो जाती है। यदि वायु में ध्वनि की चाल 345 m/s हो तो कार की चाल क्या होगी ?

Options :

40503642848. 54 km/hr

40503642849. 36 km/hr

40503642850. 24 km/hr

40503642851. 18 km/hr

Question Number : 10 Question Id : 40503611840 Question Type : MCQ Option Shuffling : Yes
Display Question Number : Yes Is Question Mandatory : No Single Line Question Option : No Option
Orientation : Vertical

Correct Marks : 4 Wrong Marks : 1

Ten charges are placed on the circumference of a circle of radius R with constant angular separation between successive charges. Alternate charges 1, 3, 5, 7, 9 have charge $(+q)$ each, while 2, 4, 6, 8, 10 have charge $(-q)$ each. The potential V and the electric field E at the centre of the circle are respectively :

(Take $V = 0$ at infinity)

Options :

40503642852. $V = 0 ; E = 0$

40503642853. $V = 0 ; E = \frac{10q}{4\pi\epsilon_0 R^2}$

40503642854. $V = \frac{10q}{4\pi\epsilon_0 R} ; E = 0$

40503642855. $V = \frac{10q}{4\pi\epsilon_0 R} ; E = \frac{10q}{4\pi\epsilon_0 R^2}$

Question Number : 10 Question Id : 40503611840 Question Type : MCQ Option Shuffling : Yes
Display Question Number : Yes Is Question Mandatory : No Single Line Question Option : No Option
Orientation : Vertical

Correct Marks : 4 Wrong Marks : 1

त्रिज्या R के एक वृत्त की परिधि पर 10 आवेश ऐसे रखे गये हैं जिससे क्रमागत आवेशों के बीच कोणीय दूरी समान रहें। एकान्तर आवेशों 1, 3, 5, 7, 9 के ऊपर क्रमशः (+q) आवेश और 2, 4, 6, 8, 10 के ऊपर क्रमशः (-q) आवेश हैं। वृत्त के केन्द्र पर विभव (V) और विद्युत क्षेत्र (E) होगी :

(अनन्त पर $V=0$ लीजिए)

Options :

40503642852. $V=0 ; E=0$

40503642853. $V=0 ; E=\frac{10q}{4\pi\epsilon_0 R^2}$

40503642854. $V=\frac{10q}{4\pi\epsilon_0 R} ; E=0$

40503642855. $V=\frac{10q}{4\pi\epsilon_0 R} ; E=\frac{10q}{4\pi\epsilon_0 R^2}$

Question Number : 11 Question Id : 40503611841 Question Type : MCQ Option Shuffling : Yes Display Question Number : Yes Is Question Mandatory : No Single Line Question Option : No Option Orientation : Vertical

Correct Marks : 4 Wrong Marks : 1

A parallel plate capacitor has plate of length 'l', width 'w' and separation of plates is 'd'. It is connected to a battery of emf V. A dielectric slab of the same thickness 'd' and of dielectric constant $k=4$ is being inserted between the plates of the capacitor. At what length of the slab inside plates, will the energy stored in the capacitor be two times the initial energy stored ?

Options :

40503642856. $l/3$

40503642857. $2l/3$

40503642858. $1/2$

40503642859. $1/4$

Question Number : 11 Question Id : 40503611841 Question Type : MCQ Option Shuffling : Yes Display Question Number : Yes Is Question Mandatory : No Single Line Question Option : No Option Orientation : Vertical

Correct Marks : 4 Wrong Marks : 1

एक समान्तर प्लेट संधारित्र की प्लेट की लम्बाई ' l ', चौड़ाई ' w ' और उसके प्लेटों के बीच की दूरी ' d ' है। इसको एक विद्युत वाहक बल (emf) V वाली बैटरी से जोड़ा जाता है। उसी मोटाई ' d ' और परावैद्युतांक $k=4$ के एक परावैद्युत गुटके को संधारित्र की प्लेटों के बीच घुसाया जाता है। प्लेटों के अंदर गुटके को कितना घुसाने पर, संधारित्र में संचित ऊर्जा पहले वाली संचित ऊर्जा की दोगुनी होगी ?

Options :

40503642856. $1/3$

40503642857. $2/3$

40503642858. $1/2$

40503642859. $1/4$

Question Number : 12 Question Id : 40503611842 Question Type : MCQ Option Shuffling : Yes Display Question Number : Yes Is Question Mandatory : No Single Line Question Option : No Option Orientation : Vertical

Correct Marks : 4 Wrong Marks : 1

In the circuit, given in the figure currents in different branches and value of one resistor are shown. Then potential at point B with respect to the point A is :

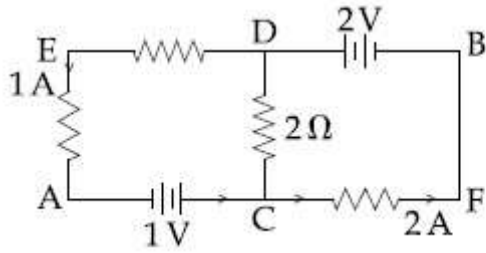

Options :

40503642860. +1 V

40503642861. -1 V

40503642862. +2 V

40503642863. -2 V

Question Number : 12 Question Id : 40503611842 Question Type : MCQ Option Shuffling : Yes Display Question Number : Yes Is Question Mandatory : No Single Line Question Option : No Option Orientation : Vertical

Correct Marks : 4 Wrong Marks : 1

दिये गये परिपथ में विभिन्न शाखाओं में धारा और एक प्रतिरोध का मान दिखाये गये हैं। बिंदु A के सापेक्ष बिंदु B का विभव है :

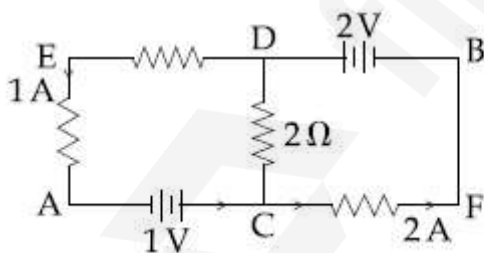

Options :

40503642860. +1 V

40503642861. -1 V

40503642862. +2 V

40503642863. -2 V

Question Number : 13 Question Id : 40503611843 Question Type : MCQ Option Shuffling : Yes Display Question Number : Yes Is Question Mandatory : No Single Line Question Option : No Option Orientation : Vertical

Correct Marks : 4 Wrong Marks : 1

In the circuit shown, charge on the $5\ \mu\text{F}$ capacitor is :

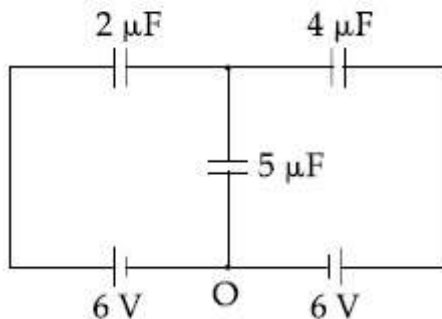

Options :

40503642864. $5.45\ \mu\text{C}$

40503642865. $16.36\ \mu\text{C}$

40503642866. $10.90\ \mu\text{C}$

40503642867. $18.00\ \mu\text{C}$

Question Number : 13 Question Id : 40503611843 Question Type : MCQ Option Shuffling : Yes Display Question Number : Yes Is Question Mandatory : No Single Line Question Option : No Option Orientation : Vertical

Correct Marks : 4 Wrong Marks : 1

दिये गये परिपथ में संधारित्र $5\ \mu\text{F}$ पर आवेश है :

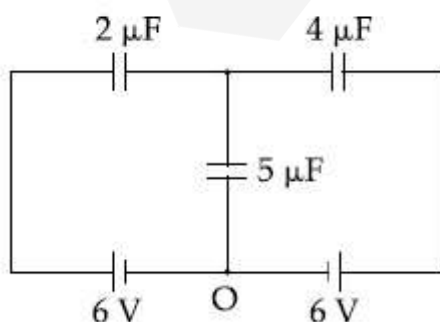

Options :

40503642864. $5.45 \mu\text{C}$

40503642865. $16.36 \mu\text{C}$

40503642866. $10.90 \mu\text{C}$

40503642867. $18.00 \mu\text{C}$

Question Number : 14 Question Id : 40503611844 Question Type : MCQ Option Shuffling : Yes Display Question Number : Yes Is Question Mandatory : No Single Line Question Option : No Option Orientation : Vertical

Correct Marks : 4 Wrong Marks : 1

An infinitely long straight wire carrying current I , one side opened rectangular loop and a conductor C with a sliding connector are located in the same plane, as shown in the figure. The connector has length l and resistance R . It slides to the right with a velocity v . The resistance of the conductor and the self inductance of the loop are negligible. The induced current in the loop, as a function of separation r , between the connector and the straight wire is :

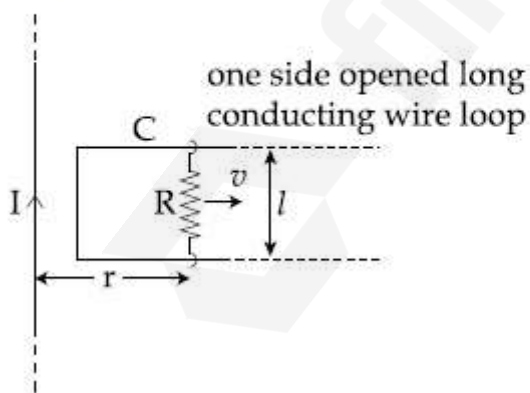

Options :

40503642868. $\frac{\mu_0}{4\pi} \frac{Ivl}{Rr}$

40503642869. $\frac{\mu_0}{2\pi} \frac{Ivl}{Rr}$

40503642870. $\frac{\mu_0}{\pi} \frac{Ivl}{Rr}$

40503642871. $\frac{2\mu_0}{\pi} \frac{Ivl}{Rr}$

Question Number : 14 Question Id : 40503611844 Question Type : MCQ Option Shuffling : Yes Display Question Number : Yes Is Question Mandatory : No Single Line Question Option : No Option Orientation : Vertical

Correct Marks : 4 Wrong Marks : 1

प्रवाहित धारा I वाला एक अनन्त लम्बाई का लम्बा सीधा तार, एक तरफ से खुला आयताकार लूप और खिसकाने वाले संयोजक सहित चालक C एक ही तल में स्थित हैं, जैसा कि चित्र में दर्शाया गया है। संयोजक जिसकी लंबाई l और प्रतिरोध R है, दाहिनी तरफ v वेग से खिसकता है। विद्युत चालक C का प्रतिरोध और लूप का स्वप्रेरकत्व नगण्य है। यदि सीधे तार एवं संयोजक के बीच की दूरी r हो तो लूप में प्रेरित धारा होगी :

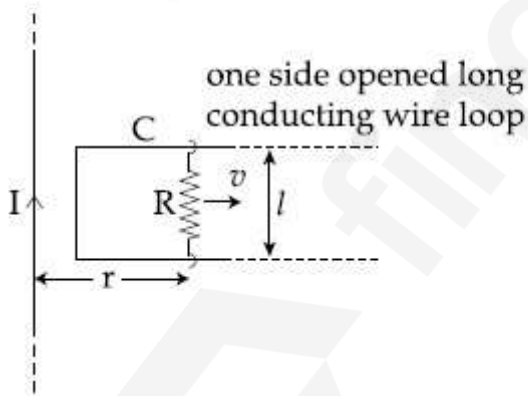

Options :

40503642868. $\frac{\mu_0}{4\pi} \frac{Ivl}{Rr}$

40503642869. $\frac{\mu_0}{2\pi} \frac{Ivl}{Rr}$

$$40503642870. \frac{\mu_0}{\pi} \frac{Ivl}{Rr}$$

$$40503642871. \frac{2\mu_0}{\pi} \frac{Ivl}{Rr}$$

Question Number : 15 Question Id : 40503611845 Question Type : MCQ Option Shuffling : Yes Display Question Number : Yes Is Question Mandatory : No Single Line Question Option : No Option Orientation : Vertical

Correct Marks : 4 Wrong Marks : 1

An iron rod of volume 10^{-3} m^3 and relative permeability 1000 is placed as core in a solenoid with 10 turns/cm. If a current of 0.5 A is passed through the solenoid, then the magnetic moment of the rod will be :

Options :

$$40503642872. 5 \times 10^2 \text{ Am}^2$$

$$40503642873. 50 \times 10^2 \text{ Am}^2$$

$$40503642874. 500 \times 10^2 \text{ Am}^2$$

$$40503642875. 0.5 \times 10^2 \text{ Am}^2$$

Question Number : 15 Question Id : 40503611845 Question Type : MCQ Option Shuffling : Yes Display Question Number : Yes Is Question Mandatory : No Single Line Question Option : No Option Orientation : Vertical

Correct Marks : 4 Wrong Marks : 1

10^{-3} m^3 आयतन एवं 1000 सापेक्षिक चुम्बकशीलता की एक लोहे की छड़ को एक परिनालिका में क्रोड की तरह रखा गया है। परिनालिका में फेरों की संख्या 10 फेरे/cm है। यदि 0.5 A धारा परिनालिका में प्रवाहित की जाये तो छड़ का चुम्बकीय आघूर्ण होगा :

Options :

$$40503642872. 5 \times 10^2 \text{ Am}^2$$

40503642873. $50 \times 10^2 \text{ Am}^2$

40503642874. $500 \times 10^2 \text{ Am}^2$

40503642875. $0.5 \times 10^2 \text{ Am}^2$

Question Number : 16 Question Id : 40503611846 Question Type : MCQ Option Shuffling : Yes Display Question Number : Yes Is Question Mandatory : No Single Line Question Option : No Option Orientation : Vertical

Correct Marks : 4 Wrong Marks : 1

The correct match between the entries in column I and column II are :

I	II
Radiation	Wavelength
(a) Microwave	(i) 100 m
(b) Gamma rays	(ii) 10^{-15} m
(c) A.M. radio waves	(iii) 10^{-10} m
(d) X-rays	(iv) 10^{-3} m

Options :

40503642876. (a)-(iv), (b)-(ii), (c)-(i), (d)-(iii)

40503642877. (a)-(i), (b)-(iii), (c)-(iv), (d)-(ii)

40503642878. (a)-(iii), (b)-(ii), (c)-(i), (d)-(iv)

40503642879. (a)-(ii), (b)-(i), (c)-(iv), (d)-(iii)

Question Number : 16 Question Id : 40503611846 Question Type : MCQ Option Shuffling : Yes Display Question Number : Yes Is Question Mandatory : No Single Line Question Option : No Option Orientation : Vertical

Correct Marks : 4 Wrong Marks : 1

सूची I तथा सूची II की प्रविष्टियों के बीच सही मिलन है :

I	II
विकिरण	तरंगदैर्घ्य
(a) सूक्ष्म तरंग	(i) 100 m
(b) गामा किरणें	(ii) 10^{-15} m
(c) ए.एम. रेडियो तरंगें	(iii) 10^{-10} m
(d) X-किरणें	(iv) 10^{-3} m

Options :

40503642876. (a)-(iv), (b)-(ii), (c)-(i), (d)-(iii)

40503642877. (a)-(i), (b)-(iii), (c)-(iv), (d)-(ii)

40503642878. (a)-(iii), (b)-(ii), (c)-(i), (d)-(iv)

40503642879. (a)-(ii), (b)-(i), (c)-(iv), (d)-(iii)

Question Number : 17 Question Id : 40503611847 Question Type : MCQ Option Shuffling : Yes
Display Question Number : Yes Is Question Mandatory : No Single Line Question Option : No Option
Orientation : Vertical

Correct Marks : 4 Wrong Marks : 1

Two coherent sources of sound, S_1 and S_2 , produce sound waves of the same wavelength, $\lambda = 1$ m, in phase. S_1 and S_2 are placed 1.5 m apart (see fig). A listener, located at L, directly in front of S_2 finds that the intensity is at a minimum when he is 2 m away from S_2 . The listener moves away from S_1 , keeping his distance from S_2 fixed. The adjacent maximum of intensity is observed when the listener is at a distance d from S_1 . Then, d is :

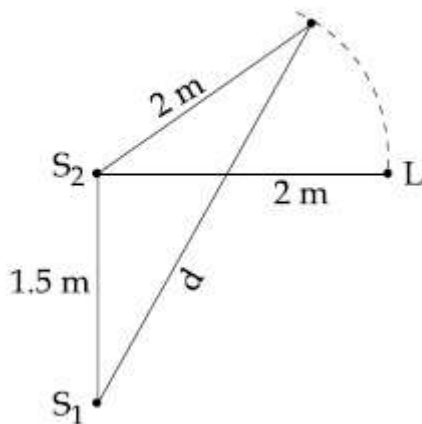

Options :

40503642880. 12 m

40503642881. 2 m

40503642882. 3 m

40503642883. 5 m

Question Number : 17 Question Id : 40503611847 Question Type : MCQ Option Shuffling : Yes
 Display Question Number : Yes Is Question Mandatory : No Single Line Question Option : No Option
 Orientation : Vertical

Correct Marks : 4 Wrong Marks : 1

दो कलासंबद्ध ध्वनि स्रोत, S_1 और S_2 , समान तरंगदैर्घ्य $\lambda = 1 \text{ m}$ एवं समान कला की ध्वनि तरंगें पैदा करते हैं। S_1 और S_2 एक दूसरे से 1.5 m की दूरी पर रखे गये हैं (चित्र देखिये)। एक श्रोता, जो कि S_2 के ठीक सामने 2 m दूरी पर L पर स्थित है, तीव्रता न्यूनतम मापता है। श्रोता S_1 से दूर जाता है जबकि S_2 से उसकी दूरी समान बनी रहती है। श्रोता जब S_1 से d दूरी पर है तो तीव्रता सन्निकट अधिकतम पर होती है। तो d का मान होगा :

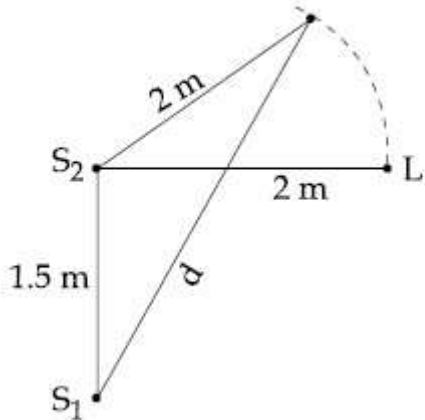

Options :

40503642880. 12 m
40503642881. 2 m
40503642882. 3 m
40503642883. 5 m

Question Number : 18 Question Id : 40503611848 Question Type : MCQ Option Shuffling : Yes Display Question Number : Yes Is Question Mandatory : No Single Line Question Option : No Option Orientation : Vertical

Correct Marks : 4 Wrong Marks : 1

A radioactive nucleus decays by two different processes. The half life for the first process is 10 s and that for the second is 100 s . The effective half life of the nucleus is close to :

Options :

40503642884. 12 sec.

40503642885. 55 sec.

40503642886. 6 sec.

40503642887. 9 sec.

Question Number : 18 Question Id : 40503611848 Question Type : MCQ Option Shuffling : Yes Display Question Number : Yes Is Question Mandatory : No Single Line Question Option : No Option Orientation : Vertical

Correct Marks : 4 Wrong Marks : 1

एक रेडियोएक्टिव नाभिक दो अलग-अलग प्रक्रियाओं से विघटित होता है। पहली प्रक्रिया की अर्धायु 10 s है और दूसरी की 100 s है। उस नाभिक की प्रभावी अर्धायु का निकटतम मान है :

Options :

40503642884. 12 sec.

40503642885. 55 sec.

40503642886. 6 sec.

40503642887. 9 sec.

Question Number : 19 Question Id : 40503611849 Question Type : MCQ Option Shuffling : Yes Display Question Number : Yes Is Question Mandatory : No Single Line Question Option : No Option Orientation : Vertical

Correct Marks : 4 Wrong Marks : 1

Two Zener diodes (A and B) having breakdown voltages of 6 V and 4 V respectively, are connected as shown in the circuit below. The output voltage V_o variation with input voltage linearly increasing with time, is given by :
 ($V_{\text{input}} = 0 \text{ V}$ at $t = 0$)
 (figures are qualitative)

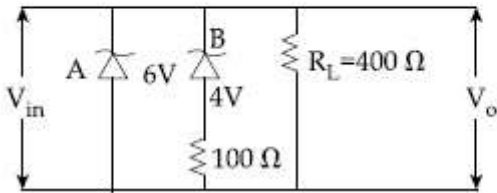

Options :

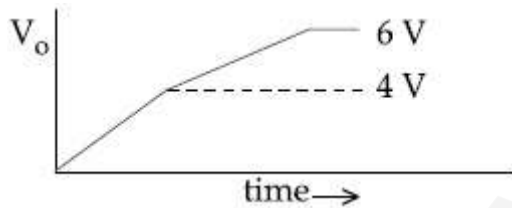

40503642888.

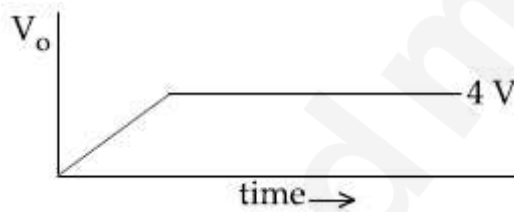

40503642889.

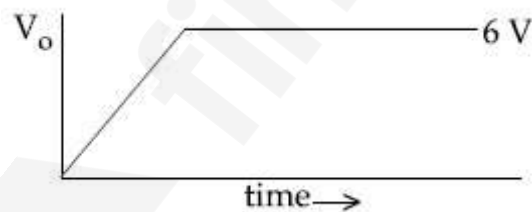

40503642890.

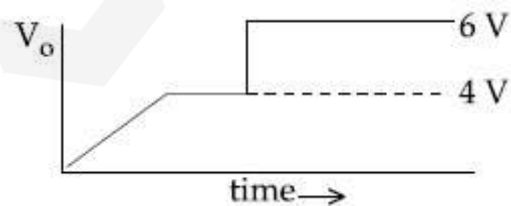

40503642891.

Orientation : Vertical

Correct Marks : 4 Wrong Marks : 1

नीचे दर्शाये गये परिपथ में क्रमशः 6 V एवं 4 V भंजन वोल्टता वाले दो जेनर डायोड (A एवं B) जोड़े गये हैं। रेखिक वृद्धितर निवेश वोल्टता पर समय का निर्गत वोल्टता V_o से परिवर्तन इससे दिया जाता है : ($t=0$ पर V का मान $V_{निवेश}=0$) (चित्र संकेतात्मक हैं)

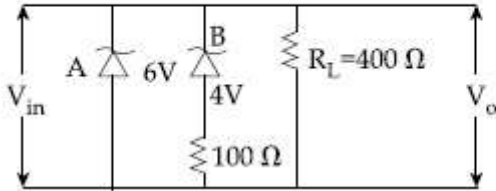

Options :

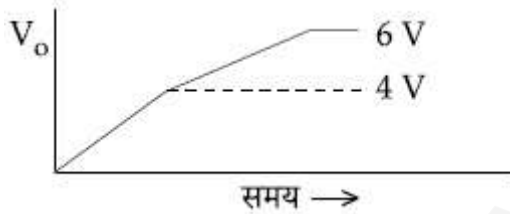

40503642888.

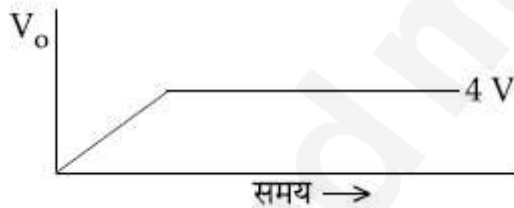

40503642889.



40503642890.

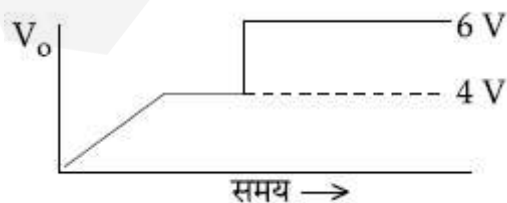

40503642891.

Display Question Number : Yes Is Question Mandatory : No Single Line Question Option : No Option
Orientation : Vertical

Correct Marks : 4 Wrong Marks : 1

A galvanometer is used in laboratory for detecting the null point in electrical experiments. If, on passing a current of 6 mA it produces a deflection of 2° , its figure of merit is close to :

Options :

40503642892. 666° A/div.

40503642893. 6×10^{-3} A/div.

40503642894. 3×10^{-3} A/div.

40503642895. 333° A/div.

Question Number : 20 Question Id : 40503611850 Question Type : MCQ Option Shuffling : Yes
Display Question Number : Yes Is Question Mandatory : No Single Line Question Option : No Option
Orientation : Vertical

Correct Marks : 4 Wrong Marks : 1

प्रयोगशाला में एक गैल्वेनोमीटर का उपयोग विद्युत प्रयोगों में शून्य विक्षेप ज्ञात करने के लिये किया जाता है। यदि 6 mA की धारा प्रवाहित करने पर इसमें 2° का विक्षेप उत्पन्न होता है, तो इसका दक्षतांक (figure of merit) लगभग होगा :

Options :

40503642892. 666° A/डिविजन

40503642893. 6×10^{-3} A/डिविजन

40503642894. 3×10^{-3} A/डिविजन

40503642895. 333° A/डिविजन

Sub-Section Number :

2

Sub-Section Id :

405036834

Question Shuffling Allowed :

Yes

Question Number : 21 Question Id : 40503611851 Question Type : SA Display Question Number : Yes
Correct Marks : 4 Wrong Marks : 0

A body of mass 2 kg is driven by an engine delivering a constant power of 1 J/s. The body starts from rest and moves in a straight line. After 9 seconds, the body has moved a distance (in m) _____.

Response Type : Numeric

Evaluation Required For SA : Yes

Show Word Count : Yes

Answers Type : Range

Text Areas : PlainText

Possible Answers :

5 to 5.002

Question Number : 21 Question Id : 40503611851 Question Type : SA Display Question Number : Yes
Correct Marks : 4 Wrong Marks : 0

2 kg की एक वस्तु एक इंजन द्वारा संचालित है जो कि 1 J/s की नियत शक्ति प्रदान कर रहा है। वह वस्तु स्थिरावस्था से गतिमान होकर सीधी रेखा में चलती है। 9 s बाद वस्तु द्वारा चली गयी दूरी (m में) होगी _____।

Response Type : Numeric

Evaluation Required For SA : Yes

Show Word Count : Yes

Answers Type : Range

Text Areas : PlainText

Possible Answers :

5 to 5.002

Question Number : 22 Question Id : 40503611852 Question Type : SA Display Question Number : Yes
Correct Marks : 4 Wrong Marks : 0

A thin rod of mass 0.9 kg and length 1 m is suspended, at rest, from one end so that it can freely oscillate in the vertical plane. A particle of mass 0.1 kg moving in a straight line with velocity 80 m/s hits the rod at its bottom most point and sticks to it (see figure). The angular speed (in rad/s) of the rod immediately after the collision will be _____.

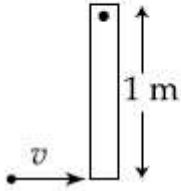

Response Type : Numeric

Evaluation Required For SA : Yes

Show Word Count : Yes

Answers Type : Range

Text Areas : PlainText

Possible Answers :

5 to 5.002

Question Number : 22 **Question Id :** 40503611852 **Question Type :** SA **Display Question Number :** Yes

Correct Marks : 4 **Wrong Marks :** 0

0.9 kg द्रव्यमान एवं 1 m लम्बाई की एक पतली छड़ अपने एक सिरे से ऐसे लटकायी गयी है कि वह ऊर्ध्वाधर समतल में विराम से स्वतंत्र गति कर सकती है। 0.1 kg का एक कण 80 m/s की गति से सीधी रेखा में चलते हुए छड़ के सबसे निचले हिस्से से टकरा कर उसमें चिपक जाता है (चित्र देखिए)। इस संघट्ट के तुरंत बाद छड़ की कोणीय गति (rad/s में) होगी

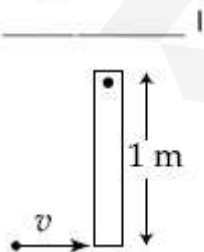

Response Type : Numeric

Evaluation Required For SA : Yes

Show Word Count : Yes

Answers Type : Range

Text Areas : PlainText

Possible Answers :

5 to 5.002

Question Number : 23 Question Id : 40503611853 Question Type : SA Display Question Number : Yes

Correct Marks : 4 Wrong Marks : 0

Nitrogen gas is at 300°C temperature. The temperature (in K) at which the rms speed of a H_2 molecule would be equal to the rms speed of a nitrogen molecule, is _____.

(Molar mass of N_2 gas 28 g).

Response Type : Numeric

Evaluation Required For SA : Yes

Show Word Count : Yes

Answers Type : Range

Text Areas : PlainText

Possible Answers :

5 to 5.002

Question Number : 23 Question Id : 40503611853 Question Type : SA Display Question Number : Yes

Correct Marks : 4 Wrong Marks : 0

नाइट्रोजन गैस 300°C तापमान पर रखी गयी है। वह तापमान (K में), जिस पर हाइड्रोजन अणु का वर्ग-माध्य-मूल (rms) वेग नाइट्रोजन अणु के वर्ग-माध्य-मूल वेग के बराबर होगा, है _____ ।

(N_2 गैस का मोलर द्रव्यमान 28 g हैं)

Response Type : Numeric

Evaluation Required For SA : Yes

Show Word Count : Yes

Answers Type : Range

Text Areas : PlainText

Possible Answers :

5 to 5.002

Question Number : 24 Question Id : 40503611854 Question Type : SA Display Question Number : Yes

Correct Marks : 4 Wrong Marks : 0

A prism of angle $A=1^\circ$ has a refractive index $\mu=1.5$. A good estimate for the minimum angle of deviation (in degrees) is close to $N/10$. Value of N is _____.

Response Type : Numeric

Evaluation Required For SA : Yes

Show Word Count : Yes

Answers Type : Range

Text Areas : PlainText

Possible Answers :

5 to 5.002

Question Number : 24 **Question Id :** 40503611854 **Question Type :** SA Display **Question Number :** Yes

Correct Marks : 4 **Wrong Marks :** 0

एक प्रिज्म, जिसके पदार्थ का अपवर्तनांक 1.5 है, का कोण $A=1^\circ$ है। उसके विचलन कोण का निकटतम आकलन (डिग्री में) $N/10$ होगा। N का मान है _____।

Response Type : Numeric

Evaluation Required For SA : Yes

Show Word Count : Yes

Answers Type : Range

Text Areas : PlainText

Possible Answers :

5 to 5.002

Question Number : 25 **Question Id :** 40503611855 **Question Type :** SA Display **Question Number :** Yes

Correct Marks : 4 **Wrong Marks :** 0

The surface of a metal is illuminated alternately with photons of energies $E_1=4\text{ eV}$ and $E_2=2.5\text{ eV}$ respectively. The ratio of maximum speeds of the photoelectrons emitted in the two cases is 2. The work function of the metal in (eV) is _____.

Response Type : Numeric

Evaluation Required For SA : Yes

Show Word Count : Yes

Answers Type : Range

Text Areas : PlainText

Possible Answers :

5 to 5.002

Question Number : 25 Question Id : 40503611855 Question Type : SA Display Question Number : Yes

Correct Marks : 4 Wrong Marks : 0

एक धातु की सतह क्रमशः $E_1 = 4 \text{ eV}$ और $E_2 = 2.5 \text{ eV}$ की ऊर्जा के फोटानों द्वारा प्रकाशित की जाती है। इन दो स्थितियों में उत्सर्जित प्रकाश-इलेक्ट्रॉनों की अधिकतम गतियों का अनुपात 2 है। इस धातु का कार्य फलन (eV में) होगा _____।

Response Type : Numeric

Evaluation Required For SA : Yes

Show Word Count : Yes

Answers Type : Range

Text Areas : PlainText

Possible Answers :

5 to 5.002

Chemistry

Section Id :	405036434
Section Number :	2
Section type :	Online
Mandatory or Optional :	Mandatory
Number of Questions :	25
Number of Questions to be attempted :	25
Section Marks :	100
Display Number Panel :	Yes
Group All Questions :	Yes
Mark As Answered Required? :	Yes
Sub-Section Number :	1
Sub-Section Id :	405036835
Question Shuffling Allowed :	Yes

Question Number : 26 Question Id : 40503611856 Question Type : MCQ Option Shuffling : Yes

Display Question Number : Yes Is Question Mandatory : No Single Line Question Option : No Option

Orientation : Vertical

Correct Marks : 4 Wrong Marks : 1

Among the following compounds,
geometrical isomerism is exhibited by :

Options :

40503642901.



40503642902.

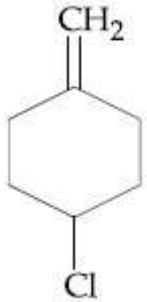

40503642903.

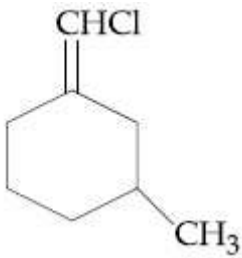

40503642904.

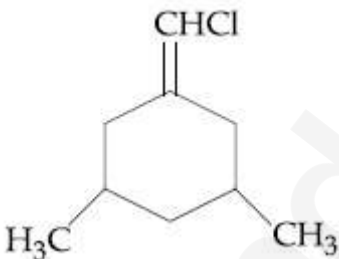

Question Number : 26 Question Id : 40503611856 Question Type : MCQ Option Shuffling : Yes Display Question Number : Yes Is Question Mandatory : No Single Line Question Option : No Option Orientation : Vertical

Correct Marks : 4 Wrong Marks : 1

निम्नलिखित यौगिकों में से ज्यामितीय समावयवता प्रदर्शित करने वाला यौगिक है :

Options :

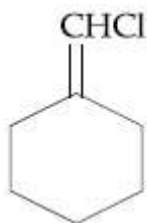

40503642901.

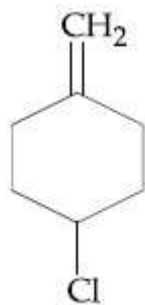

40503642902.

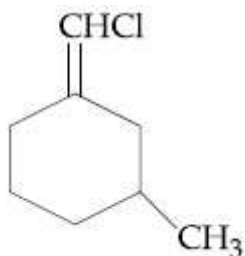

40503642903.

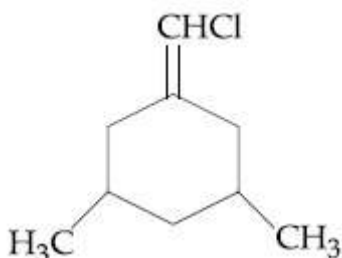

40503642904.

Question Number : 27 Question Id : 40503611857 Question Type : MCQ Option Shuffling : Yes Display Question Number : Yes Is Question Mandatory : No Single Line Question Option : No Option Orientation : Vertical

Correct Marks : 4 Wrong Marks : 1

The final major product of the following reaction is :

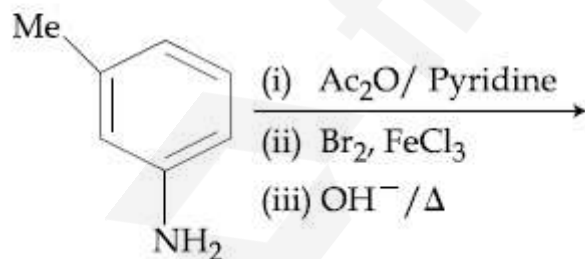

Options :

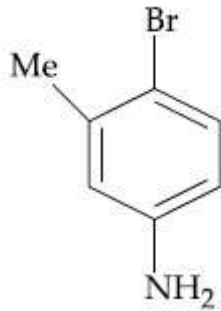

40503642905.

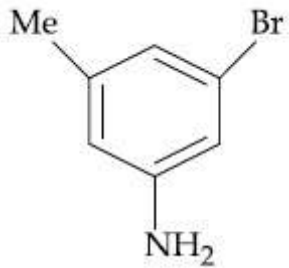

40503642906.

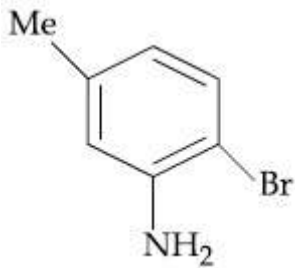

40503642907.

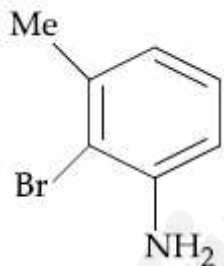

40503642908.

Question Number : 27 Question Id : 40503611857 Question Type : MCQ Option Shuffling : Yes Display Question Number : Yes Is Question Mandatory : No Single Line Question Option : No Option Orientation : Vertical

Correct Marks : 4 Wrong Marks : 1

निम्नलिखित अभिक्रिया का अंतिम मुख्य उत्पाद है :

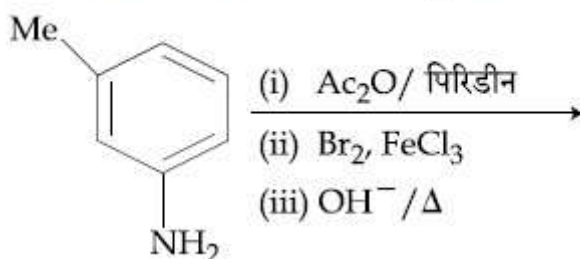

Options :

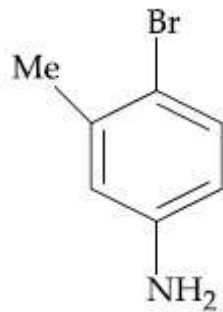

40503642905.

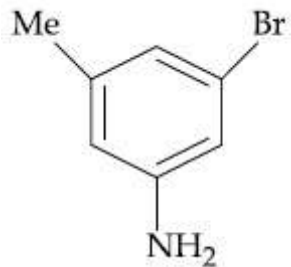

40503642906.

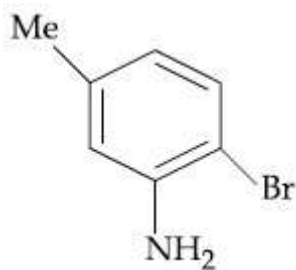

40503642907.

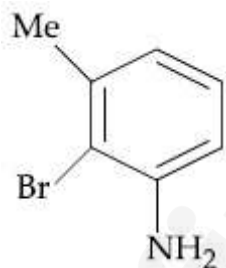

40503642908.

Question Number : 28 Question Id : 40503611858 Question Type : MCQ Option Shuffling : Yes Display Question Number : Yes Is Question Mandatory : No Single Line Question Option : No Option Orientation : Vertical

Correct Marks : 4 Wrong Marks : 1

Which one of the following polymers is not obtained by condensation polymerisation?

Options :

40503642909. Nylon 6, 6

40503642910. Nylon 6

40503642911. Bakelite

40503642912. Buna - N

Question Number : 28 Question Id : 40503611858 Question Type : MCQ Option Shuffling : Yes Display Question Number : Yes Is Question Mandatory : No Single Line Question Option : No Option Orientation : Vertical

Correct Marks : 4 Wrong Marks : 1

निम्नलिखित बहुलकों में से कौन-सा संघनन बहुलकन के द्वारा नहीं प्राप्त होता है?

Options :

40503642909. नाइलॉन 6, 6

40503642910. नाइलॉन 6

40503642911. बेकेलाइट

40503642912. ब्यूना - N

Question Number : 29 Question Id : 40503611859 Question Type : MCQ Option Shuffling : Yes Display Question Number : Yes Is Question Mandatory : No Single Line Question Option : No Option Orientation : Vertical

Correct Marks : 4 Wrong Marks : 1

The following molecule acts as an :

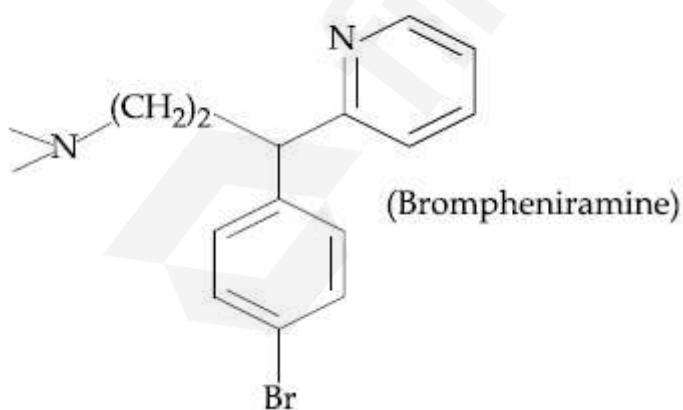

Options :

40503642913. Anti-depressant

40503642914. Anti-bacterial

40503642915. Antiseptic

40503642916. Anti-histamine

Question Number : 29 Question Id : 40503611859 Question Type : MCQ Option Shuffling : Yes
 Display Question Number : Yes Is Question Mandatory : No Single Line Question Option : No Option
 Orientation : Vertical
 Correct Marks : 4 Wrong Marks : 1

निम्नलिखित अणु किसकी तरह उपयोग में आता है ?

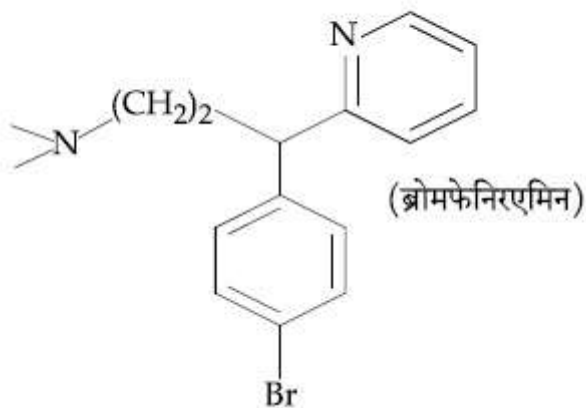

Options :

40503642913. प्रति-अवसादक

40503642914. प्रति-सूक्ष्मजैविक

40503642915. प्रतिरोधी

40503642916. प्रति-हिस्टैमिन

Question Number : 30 Question Id : 40503611860 Question Type : MCQ Option Shuffling : Yes
 Display Question Number : Yes Is Question Mandatory : No Single Line Question Option : No Option
 Orientation : Vertical
 Correct Marks : 4 Wrong Marks : 1

The major product of the following reaction is :

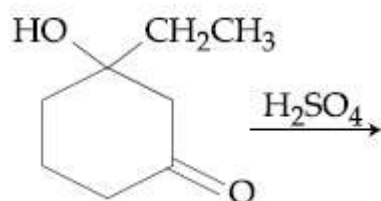

Options :

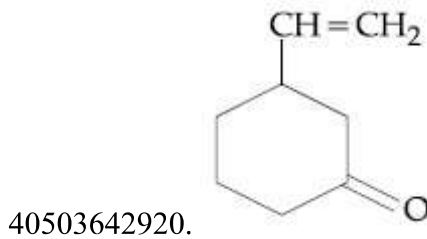
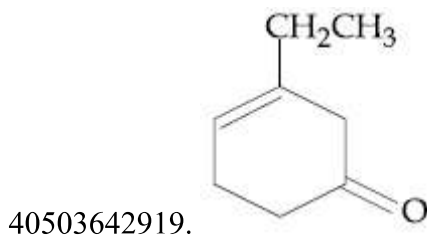
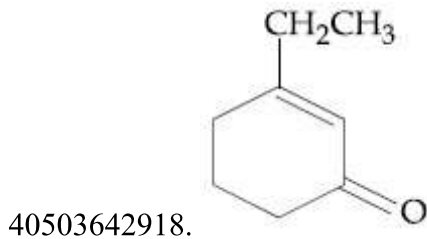
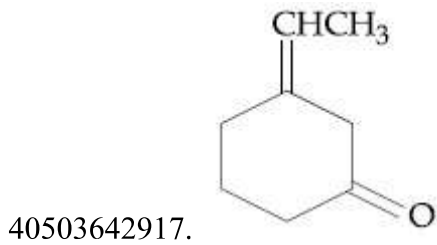

Question Number : 30 Question Id : 40503611860 Question Type : MCQ Option Shuffling : Yes
 Display Question Number : Yes Is Question Mandatory : No Single Line Question Option : No Option
 Orientation : Vertical

Correct Marks : 4 Wrong Marks : 1

निम्नलिखित अभिक्रिया का मुख्य उत्पाद है :

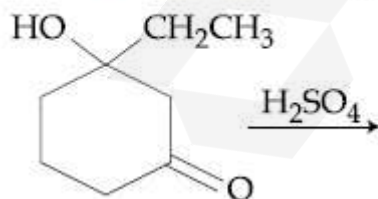

Options :



40503642917.



40503642918.

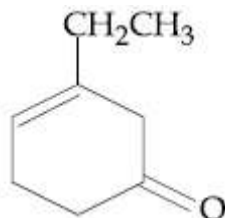

40503642919.

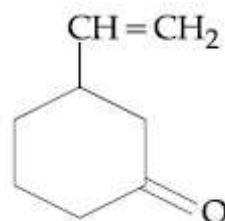

40503642920.

Question Number : 31 Question Id : 40503611861 Question Type : MCQ Option Shuffling : Yes Display Question Number : Yes Is Question Mandatory : No Single Line Question Option : No Option Orientation : Vertical

Correct Marks : 4 Wrong Marks : 1

The major product formed in the following reaction is :



Options :

40503642921. $\text{CH}_3\text{CH}(\text{Br})\text{CH}_2\text{CH}(\text{CH}_3)_2$

40503642922. $\text{CH}_3\text{CH}_2\text{CH}(\text{Br})\text{CH}(\text{CH}_3)_2$

40503642923. $\text{CH}_3\text{CH}_2\text{CH}_2\text{C}(\text{Br})(\text{CH}_3)_2$

40503642924. $\text{Br}(\text{CH}_2)_3 \text{CH}(\text{CH}_3)_2$

Question Number : 31 Question Id : 40503611861 Question Type : MCQ Option Shuffling : Yes Display Question Number : Yes Is Question Mandatory : No Single Line Question Option : No Option Orientation : Vertical

Correct Marks : 4 Wrong Marks : 1

निम्नलिखित अभिक्रिया में बनने वाला मुख्य उत्पाद है :



Options :

40503642921. $\text{CH}_3 \text{CH}(\text{Br}) \text{CH}_2 \text{CH}(\text{CH}_3)_2$

40503642922. $\text{CH}_3 \text{CH}_2 \text{CH}(\text{Br}) \text{CH}(\text{CH}_3)_2$

40503642923. $\text{CH}_3 \text{CH}_2 \text{CH}_2 \text{C}(\text{Br}) (\text{CH}_3)_2$

40503642924. $\text{Br}(\text{CH}_2)_3 \text{CH}(\text{CH}_3)_2$

Question Number : 32 Question Id : 40503611862 Question Type : MCQ Option Shuffling : Yes Display Question Number : Yes Is Question Mandatory : No Single Line Question Option : No Option Orientation : Vertical

Correct Marks : 4 Wrong Marks : 1

The increasing order of boiling points of the following compounds is :

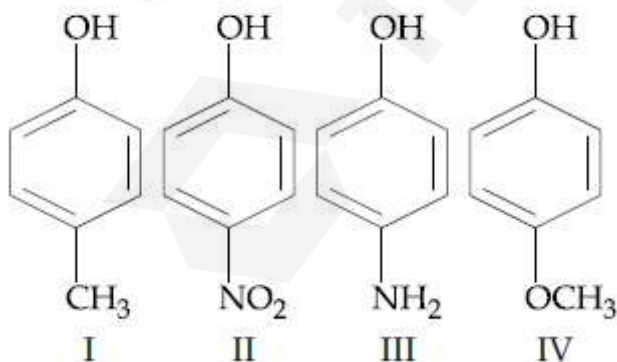

Options :

40503642925. $\text{IV} < \text{I} < \text{II} < \text{III}$

40503642926. $\text{I} < \text{IV} < \text{III} < \text{II}$

40503642927. III < I < II < IV

40503642928. I < III < IV < II

Question Number : 32 Question Id : 40503611862 Question Type : MCQ Option Shuffling : Yes Display Question Number : Yes Is Question Mandatory : No Single Line Question Option : No Option Orientation : Vertical

Correct Marks : 4 Wrong Marks : 1

निम्नलिखित यौगिकों के क्वथनांकों का बढ़ता क्रम है :

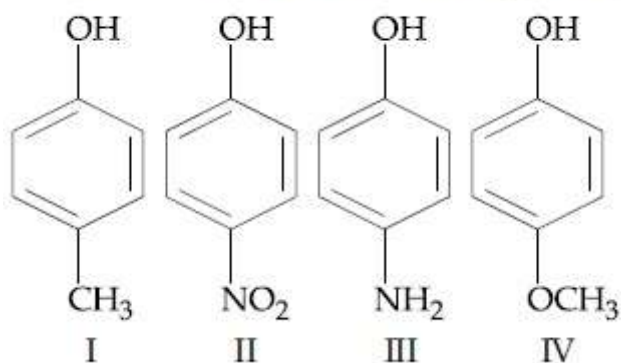

Options :

40503642925. IV < I < II < III

40503642926. I < IV < III < II

40503642927. III < I < II < IV

40503642928. I < III < IV < II

Question Number : 33 Question Id : 40503611863 Question Type : MCQ Option Shuffling : Yes Display Question Number : Yes Is Question Mandatory : No Single Line Question Option : No Option Orientation : Vertical

Correct Marks : 4 Wrong Marks : 1

The correct order of the ionic radii of

O^{2-} , N^{3-} , F^- , Mg^{2+} , Na^+ and Al^{3+} is :

Options :



40503642929. Al^{3+}

40503642930. $Al^{3+} < Mg^{2+} < Na^+ < F^- < O^{2-} < N^{3-}$

40503642931. $Al^{3+} < Na^+ < Mg^{2+} < O^{2-} < F^- < N^{3-}$

40503642932. $N^{3-} < F^- < O^{2-} < Mg^{2+} < Na^+ < Al^{3+}$

Question Number : 33 Question Id : 40503611863 Question Type : MCQ Option Shuffling : Yes Display Question Number : Yes Is Question Mandatory : No Single Line Question Option : No Option Orientation : Vertical

Correct Marks : 4 Wrong Marks : 1

O^{2-} , N^{3-} , F^- , Mg^{2+} , Na^+ तथा Al^{3+} के आयनिक त्रिज्याओं का सही क्रम है :

Options :

40503642929. $N^{3-} < O^{2-} < F^- < Na^+ < Mg^{2+} < Al^{3+}$

40503642930. $Al^{3+} < Mg^{2+} < Na^+ < F^- < O^{2-} < N^{3-}$

40503642931. $Al^{3+} < Na^+ < Mg^{2+} < O^{2-} < F^- < N^{3-}$

40503642932. $N^{3-} < F^- < O^{2-} < Mg^{2+} < Na^+ < Al^{3+}$

Question Number : 34 Question Id : 40503611864 Question Type : MCQ Option Shuffling : Yes Display Question Number : Yes Is Question Mandatory : No Single Line Question Option : No Option Orientation : Vertical

Correct Marks : 4 Wrong Marks : 1

Boron and silicon of very high purity can be obtained through :

Options :

40503642933. electrolytic refining

40503642934. liquation

40503642935. vapour phase refining

40503642936. zone refining

Question Number : 34 Question Id : 40503611864 Question Type : MCQ Option Shuffling : Yes Display Question Number : Yes Is Question Mandatory : No Single Line Question Option : No Option Orientation : Vertical

Correct Marks : 4 Wrong Marks : 1

अति शुद्ध बोरॉन तथा सिलिकन निम्नलिखित में से किसके द्वारा बनाये जा सकते हैं?

Options :

40503642933. वैद्युतअपघटनी परिष्करण

40503642934. गलनिक पृथक्करण

40503642935. वाष्प प्रावस्था परिष्करण

40503642936. मंडल परिष्करण

Question Number : 35 Question Id : 40503611865 Question Type : MCQ Option Shuffling : Yes Display Question Number : Yes Is Question Mandatory : No Single Line Question Option : No Option Orientation : Vertical

Correct Marks : 4 Wrong Marks : 1

Hydrogen peroxide, in the pure state, is :

Options :

40503642937. linear and almost colorless

40503642938. planar and blue in color

40503642939. non-planar and almost colorless

40503642940. linear and blue in color

Question Number : 35 Question Id : 40503611865 Question Type : MCQ Option Shuffling : Yes
Display Question Number : Yes Is Question Mandatory : No Single Line Question Option : No Option
Orientation : Vertical

Correct Marks : 4 Wrong Marks : 1

हाइड्रोजन परॉक्साइड शुद्ध प्रावस्था में होती है :

Options :

40503642937. रैखिक तथा लगभग रंगहीन

40503642938. समतली तथा नीले रंग की

40503642939. असमतली तथा लगभग रंगहीन

40503642940. रैखिक तथा नीले रंग की

Question Number : 36 Question Id : 40503611866 Question Type : MCQ Option Shuffling : Yes
Display Question Number : Yes Is Question Mandatory : No Single Line Question Option : No Option
Orientation : Vertical

Correct Marks : 4 Wrong Marks : 1

The one that is NOT suitable for the removal of permanent hardness of water is :

Options :

40503642941. Ion-exchange method

40503642942. Treatment with sodium carbonate

40503642943. Calgon's method

40503642944. Clark's method

Question Number : 36 Question Id : 40503611866 Question Type : MCQ Option Shuffling : Yes
Display Question Number : Yes Is Question Mandatory : No Single Line Question Option : No Option
Orientation : Vertical

Correct Marks : 4 Wrong Marks : 1

जल के स्थायी कठोरता को दूर करने के लिए निम्नलिखित में से कौन-सी विधि उपयुक्त नहीं है?

Options :

40503642941. आयन-विनिमय विधि
40503642942. सोडियम कार्बोनेट के साथ उपचार
40503642943. काल्गॉन विधि
40503642944. क्लार्क विधि

Question Number : 37 Question Id : 40503611867 Question Type : MCQ Option Shuffling : Yes Display Question Number : Yes Is Question Mandatory : No Single Line Question Option : No Option Orientation : Vertical

Correct Marks : 4 Wrong Marks : 1

Reaction of ammonia with excess Cl_2 gives :

Options :

40503642945. NH_4Cl and N_2
40503642946. NH_4Cl and HCl
40503642947. NCl_3 and HCl
40503642948. NCl_3 and NH_4Cl

Question Number : 37 Question Id : 40503611867 Question Type : MCQ Option Shuffling : Yes Display Question Number : Yes Is Question Mandatory : No Single Line Question Option : No Option Orientation : Vertical

Correct Marks : 4 Wrong Marks : 1

अमोनिया, Cl_2 के आधिक्य में, अभिक्रिया देती है :

Options :

40503642945. NH_4Cl तथा N_2
40503642946. NH_4Cl तथा HCl
40503642947. NCl_3 तथा HCl

40503642948. NCl_3 तथा NH_4Cl

Question Number : 38 Question Id : 40503611868 Question Type : MCQ Option Shuffling : Yes Display Question Number : Yes Is Question Mandatory : No Single Line Question Option : No Option Orientation : Vertical

Correct Marks : 4 Wrong Marks : 1

The compound that has the largest H-M-H bond angle (M=N, O, S, C), is :

Options :

40503642949. NH_3

40503642950. H_2O

40503642951. H_2S

40503642952. CH_4

Question Number : 38 Question Id : 40503611868 Question Type : MCQ Option Shuffling : Yes Display Question Number : Yes Is Question Mandatory : No Single Line Question Option : No Option Orientation : Vertical

Correct Marks : 4 Wrong Marks : 1

निम्नलिखित में से बृहत्तम H-M-H आबंध कोण (M=N, O, S, C) रखने वाला यौगिक है :

Options :

40503642949. NH_3

40503642950. H_2O

40503642951. H_2S

40503642952. CH_4

Question Number : 39 Question Id : 40503611869 Question Type : MCQ Option Shuffling : Yes Display Question Number : Yes Is Question Mandatory : No Single Line Question Option : No Option Orientation : Vertical

Correct Marks : 4 Wrong Marks : 1

Consider the complex ions,
trans-[Co(en)₂Cl₂]⁺ (A) and
cis-[Co(en)₂Cl₂]⁺ (B). The correct
statement regarding them is :

Options :

40503642953. both (A) and (B) can be optically active.

40503642954. both (A) and (B) cannot be optically active.

40503642955. (A) can be optically active, but (B) cannot be optically active.

40503642956. (A) cannot be optically active, but (B) can be optically active.

Question Number : 39 Question Id : 40503611869 Question Type : MCQ Option Shuffling : Yes Display Question Number : Yes Is Question Mandatory : No Single Line Question Option : No Option Orientation : Vertical

Correct Marks : 4 Wrong Marks : 1

ट्रान्स-[Co(en)₂Cl₂]⁺ (A) तथा
सिस-[Co(en)₂Cl₂]⁺ (B) संकुल आयनों पर विचार
कीजिए।

इनके संबंध में सही कथन है :

Options :

40503642953. (A) तथा (B) दोनों ध्रुवण घूर्णक हो सकते हैं।

40503642954. (A) तथा (B) दोनों ध्रुवण घूर्णक नहीं हो सकते हैं।

40503642955. (A) ध्रुवण घूर्णक हो सकता है, परन्तु (B) ध्रुवण घूर्णक नहीं हो सकता है।

40503642956. (A) ध्रुवण घूर्णक नहीं हो सकता है, परन्तु (B) ध्रुवण घूर्णक हो सकता है।

Question Number : 40 Question Id : 40503611870 Question Type : MCQ Option Shuffling : Yes
Display Question Number : Yes Is Question Mandatory : No Single Line Question Option : No Option
Orientation : Vertical

Correct Marks : 4 Wrong Marks : 1

An element crystallises in a face-centred cubic (fcc) unit cell with cell edge a . The distance between the centres of two nearest octahedral voids in the crystal lattice is :

Options :

40503642957. $\sqrt{2}a$

40503642958. a

40503642959. $\frac{a}{\sqrt{2}}$

40503642960. $\frac{a}{2}$

Question Number : 40 Question Id : 40503611870 Question Type : MCQ Option Shuffling : Yes
Display Question Number : Yes Is Question Mandatory : No Single Line Question Option : No Option
Orientation : Vertical

Correct Marks : 4 Wrong Marks : 1

एक तत्व फलक-केन्द्रित घनीय (fcc) एकक सेल में क्रिस्टलित होता है जिसका सेल कोर a है। क्रिस्टल जालक में दो सबसे समीपी अष्टफलकीय रिक्तियों के केन्द्रों के बीच की दूरी है :

Options :

40503642957. $\sqrt{2}a$

40503642958. a

40503642959. $\frac{a}{\sqrt{2}}$

40503642960. $\frac{a}{2}$

Question Number : 41 Question Id : 40503611871 Question Type : MCQ Option Shuffling : Yes
Display Question Number : Yes Is Question Mandatory : No Single Line Question Option : No Option
Orientation : Vertical

Correct Marks : 4 Wrong Marks : 1

The correct statement about probability density (except at infinite distance from nucleus) is :

Options :

40503642961. It can never be zero for 2s orbital

40503642962. It can be zero for 1s orbital

40503642963. It can be negative for 2p orbital

40503642964. It can be zero for 3p orbital

Question Number : 41 Question Id : 40503611871 Question Type : MCQ Option Shuffling : Yes
Display Question Number : Yes Is Question Mandatory : No Single Line Question Option : No Option
Orientation : Vertical

Correct Marks : 4 Wrong Marks : 1

प्रायिकता घनत्व के सम्बन्ध में सही कथन (नाभिक से अनन्त दूरी पर होने के अतिरिक्त) है :

Options :

40503642961. यह 2s कक्षक के लिए कभी शून्य नहीं हो सकता ।

40503642962. यह 1s कक्षक के लिए शून्य हो सकता है।

40503642963. यह 2p कक्षक के लिए ऋणात्मक हो सकता है।

40503642964. यह 3p कक्षक के लिए शून्य हो सकता है ।

Question Number : 42 Question Id : 40503611872 Question Type : MCQ Option Shuffling : Yes
Display Question Number : Yes Is Question Mandatory : No Single Line Question Option : No Option
Orientation : Vertical

Correct Marks : 4 Wrong Marks : 1

Lattice enthalpy and enthalpy of solution of NaCl are 788 kJ mol^{-1} and 4 kJ mol^{-1} , respectively. The hydration enthalpy of NaCl is :

Options :

40503642965. 780 kJ mol^{-1}

40503642966. 784 kJ mol^{-1}

40503642967. -780 kJ mol^{-1}

40503642968. -784 kJ mol^{-1}

Question Number : 42 Question Id : 40503611872 Question Type : MCQ Option Shuffling : Yes
Display Question Number : Yes Is Question Mandatory : No Single Line Question Option : No Option
Orientation : Vertical

Correct Marks : 4 Wrong Marks : 1

NaCl की जालक एंथैल्पी तथा विलयन एंथैल्पी क्रमशः 788 kJ mol^{-1} तथा 4 kJ mol^{-1} हैं। NaCl की जल योजन एंथैल्पी है :

Options :

40503642965. 780 kJ mol^{-1}

40503642966. 784 kJ mol^{-1}

40503642967. -780 kJ mol^{-1}

40503642968. -784 kJ mol^{-1}

Question Number : 43 Question Id : 40503611873 Question Type : MCQ Option Shuffling : Yes
Display Question Number : Yes Is Question Mandatory : No Single Line Question Option : No Option
Orientation : Vertical

Correct Marks : 4 Wrong Marks : 1

The variation of molar conductivity with concentration of an electrolyte (X) in aqueous solution is shown in the given figure.

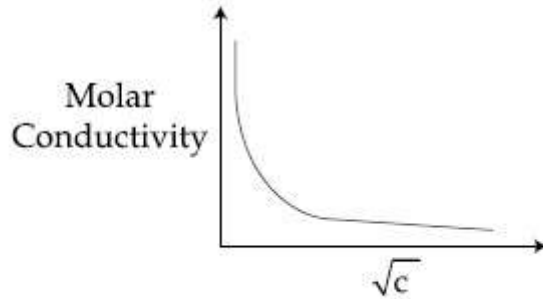

The electrolyte X is :

Options :

40503642969. HCl

40503642970. NaCl

40503642971. KNO₃

40503642972. CH₃COOH

Question Number : 43 Question Id : 40503611873 Question Type : MCQ Option Shuffling : Yes Display Question Number : Yes Is Question Mandatory : No Single Line Question Option : No Option Orientation : Vertical

Correct Marks : 4 Wrong Marks : 1

जलीय विलयन में, एक वैद्युत अपघट्य (X) की सान्द्रता के सापेक्ष मोलर चालकता के विचलन को निम्नलिखित चित्र के द्वारा निरूपित किया जाता है।

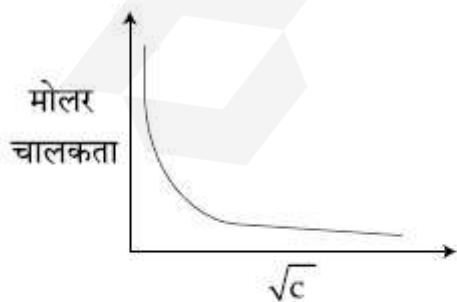

वैद्युत अपघट्य X है :

Options :

40503642969. HCl

40503642970. NaCl

40503642971. KNO₃

40503642972. CH₃COOH

Question Number : 44 Question Id : 40503611874 Question Type : MCQ Option Shuffling : Yes Display Question Number : Yes Is Question Mandatory : No Single Line Question Option : No Option Orientation : Vertical

Correct Marks : 4 Wrong Marks : 1

The rate constant (k) of a reaction is measured at different temperatures (T), and the data are plotted in the given figure. The activation energy of the reaction in kJ mol⁻¹ is : (R is gas constant)

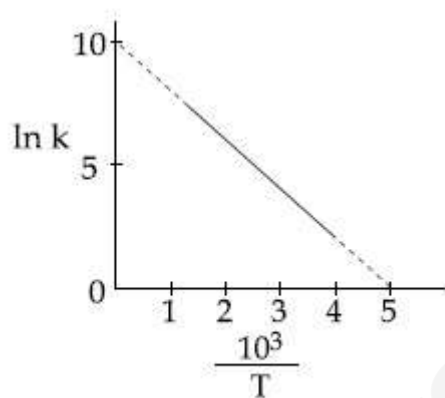

Options :

40503642973. R

40503642974. 1/R

40503642975. 2/R

40503642976. 2R

Question Number : 44 Question Id : 40503611874 Question Type : MCQ Option Shuffling : Yes Display Question Number : Yes Is Question Mandatory : No Single Line Question Option : No Option Orientation : Vertical

Correct Marks : 4 Wrong Marks : 1

एक अभिक्रिया के वेग स्थिरांक (k) को विभिन्न तापों (T) पर मापा जाता है तथा आकड़ों को नीचे दिये गये चित्र में प्लॉट किया जाता है। अभिक्रिया की सक्रियण ऊर्जा kJ mol^{-1} में है : (R गैस स्थिरांक है)

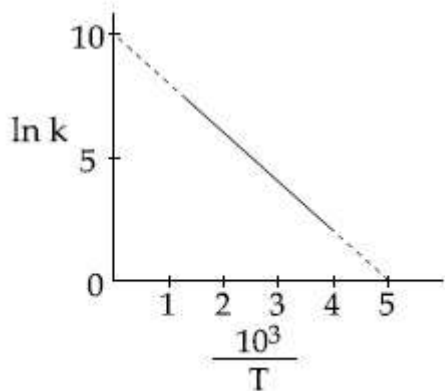

Options :

40503642973. R

40503642974. $1/R$

40503642975. $2/R$

40503642976. $2R$

Question Number : 45 Question Id : 40503611875 Question Type : MCQ Option Shuffling : Yes Display Question Number : Yes Is Question Mandatory : No Single Line Question Option : No Option Orientation : Vertical

Correct Marks : 4 Wrong Marks : 1

Adsorption of a gas follows Freundlich adsorption isotherm. If x is the mass of the gas adsorbed on mass m of the adsorbent,

the correct plot of $\frac{x}{m}$ versus p is :

Options :

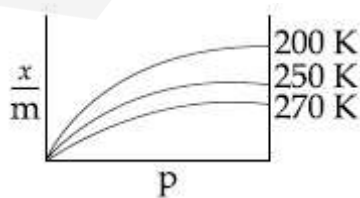

40503642977.

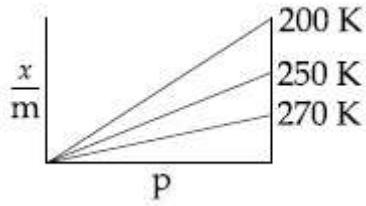

40503642978.

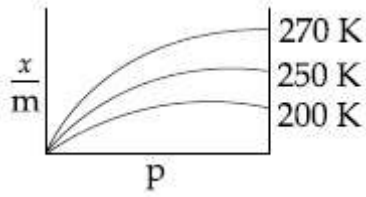

40503642979.

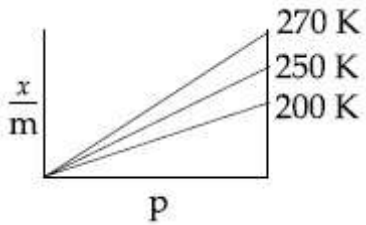

40503642980.

Question Number : 45 Question Id : 40503611875 Question Type : MCQ Option Shuffling : Yes Display Question Number : Yes Is Question Mandatory : No Single Line Question Option : No Option Orientation : Vertical

Correct Marks : 4 Wrong Marks : 1

एक गैस का अधिशोषण फ्रायन्डलिक अधिशोषण समतापी वक्र का अनुसरण करता है। यदि अधिशोषक के संहति m पर अधिशोषित गैस की संहति x है तो p

के सापेक्ष $\frac{x}{m}$ का सही प्लॉट है :

Options :

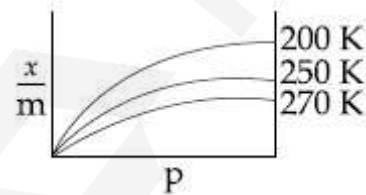

40503642977.

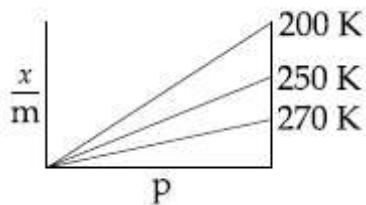

40503642978.

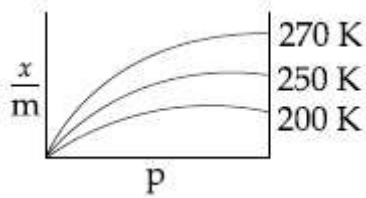

40503642979.

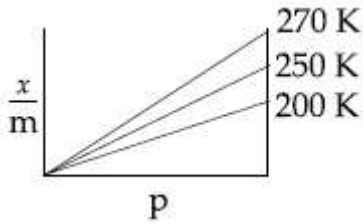

40503642980.

Sub-Section Number :

2

Sub-Section Id :

405036836

Question Shuffling Allowed :

Yes

Question Number : 46 Question Id : 40503611876 Question Type : SA Display Question Number : Yes

Correct Marks : 4 Wrong Marks : 0

Considering that $\Delta_0 > P$, the magnetic moment (in BM) of $[\text{Ru}(\text{H}_2\text{O})_6]^{2+}$ would be _____ .

Response Type : Numeric

Evaluation Required For SA : Yes

Show Word Count : Yes

Answers Type : Range

Text Areas : PlainText

Possible Answers :

5 to 5.002

Question Number : 46 Question Id : 40503611876 Question Type : SA Display Question Number : Yes

Correct Marks : 4 Wrong Marks : 0

$\Delta_0 > P$ पर विचार करते हुए, $[\text{Ru}(\text{H}_2\text{O})_6]^{2+}$ का चुंबकीय आघूर्ण (BM में) होगा _____ ।

Response Type : Numeric

Evaluation Required For SA : Yes

Show Word Count : Yes

Answers Type : Range

Text Areas : PlainText

Possible Answers :

5 to 5.002

Question Number : 47 Question Id : 40503611877 Question Type : SA Display Question Number : Yes

Correct Marks : 4 Wrong Marks : 0

The volume, in mL, of 0.02 M $K_2Cr_2O_7$ solution required to react with 0.288 g of ferrous oxalate in acidic medium is _____.

(Molar mass of Fe = 56 g mol⁻¹)

Response Type : Numeric

Evaluation Required For SA : Yes

Show Word Count : Yes

Answers Type : Range

Text Areas : PlainText

Possible Answers :

5 to 5.002

Question Number : 47 Question Id : 40503611877 Question Type : SA Display Question Number : Yes

Correct Marks : 4 Wrong Marks : 0

0.288 g फेरस ऑक्सैलेट के, अम्लीय माध्यम में, अभिक्रिया हेतु 0.02 M $K_2Cr_2O_7$ के जिस आयतन (mL में) की आवश्यकता होगी, वह है _____।

(Fe का मोलर द्रव्यमान = 56 g mol⁻¹)

Response Type : Numeric

Evaluation Required For SA : Yes

Show Word Count : Yes

Answers Type : Range

Text Areas : PlainText

Possible Answers :

5 to 5.002

Question Number : 48 Question Id : 40503611878 Question Type : SA Display Question Number : Yes

Correct Marks : 4 Wrong Marks : 0

For a dimerization reaction,

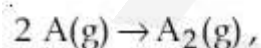

at 298 K, $\Delta U^\ominus = -20 \text{ kJ mol}^{-1}$, $\Delta S^\ominus = -30 \text{ J K}^{-1} \text{ mol}^{-1}$, then the ΔG^\ominus will be _____ J.

Response Type : Numeric

Evaluation Required For SA : Yes

Show Word Count : Yes

Answers Type : Range

Text Areas : PlainText

Possible Answers :

5 to 5.002

Question Number : 48 Question Id : 40503611878 Question Type : SA Display Question Number : Yes

Correct Marks : 4 Wrong Marks : 0

एक द्वितयन अभिक्रिया,

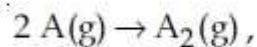

के लिए, 298 K पर, $\Delta U^\ominus = -20 \text{ kJ mol}^{-1}$,

$\Delta S^\ominus = -30 \text{ J K}^{-1} \text{ mol}^{-1}$ है। तब अभिक्रिया के लिए ΔG^\ominus होगा _____ J।

Response Type : Numeric

Evaluation Required For SA : Yes

Show Word Count : Yes

Answers Type : Range

Text Areas : PlainText

Possible Answers :

5 to 5.002

Question Number : 49 Question Id : 40503611879 Question Type : SA Display Question Number : Yes

Correct Marks : 4 Wrong Marks : 0

For a reaction $X + Y \rightleftharpoons 2Z$, 1.0 mol of X, 1.5 mol of Y and 0.5 mol of Z were taken in a 1 L vessel and allowed to react. At equilibrium, the concentration of Z was 1.0 mol L^{-1} . The equilibrium constant of

the reaction is _____ $\frac{x}{15}$. The value of x is _____.

Response Type : Numeric

Evaluation Required For SA : Yes

Show Word Count : Yes

Answers Type : Range

Text Areas : PlainText

Possible Answers :

5 to 5.002

Question Number : 49 Question Id : 40503611879 Question Type : SA Display Question Number : Yes

Correct Marks : 4 Wrong Marks : 0

अभिक्रिया, $X + Y = 2Z$ के लिए, X का 1.0 मोल, Y का 1.5 मोल तथा Z के 0.5 मोल को 1 L पात्र में लिया जाता है तथा उन्हें अभिक्रिया करने दिया जाता है। साम्य पर, Z की सान्द्रता 1.0 मोल प्रतिलीटर है। अभिक्रिया का साम्य स्थिरांक है _____

$\frac{x}{15}$ । x का मान है _____।

Response Type : Numeric

Evaluation Required For SA : Yes

Show Word Count : Yes

Answers Type : Range

Text Areas : PlainText

Possible Answers :

5 to 5.002

Question Number : 50 **Question Id :** 40503611880 **Question Type :** SA Display **Question Number :** Yes

Correct Marks : 4 **Wrong Marks :** 0

The number of chiral carbons present in sucrose is _____.

Response Type : Numeric

Evaluation Required For SA : Yes

Show Word Count : Yes

Answers Type : Range

Text Areas : PlainText

Possible Answers :

5 to 5.002

Question Number : 50 **Question Id :** 40503611880 **Question Type :** SA Display **Question Number :** Yes

Correct Marks : 4 **Wrong Marks :** 0

सुक्रोस में काइरल कार्बनों की संख्या है _____।

Response Type : Numeric

Evaluation Required For SA : Yes

Show Word Count : Yes

Answers Type : Range

Text Areas : PlainText

Possible Answers :

5 to 5.002

Mathematics

Section Id :	405036435
Section Number :	3
Section type :	Online
Mandatory or Optional :	Mandatory
Number of Questions :	25
Number of Questions to be attempted :	25
Section Marks :	100
Display Number Panel :	Yes
Group All Questions :	Yes
Mark As Answered Required? :	Yes
Sub-Section Number :	1
Sub-Section Id :	405036837
Question Shuffling Allowed :	Yes

Question Number : 51 Question Id : 40503611881 Question Type : MCQ Option Shuffling : Yes
 Display Question Number : Yes Is Question Mandatory : No Single Line Question Option : No Option
 Orientation : Vertical
 Correct Marks : 4 Wrong Marks : 1

The value of $\left(\frac{-1+i\sqrt{3}}{1-i}\right)^{30}$ is :

Options :

40503642986. 6^5

40503642987. -2^{15}

40503642988. $2^{15}i$

40503642989. $-2^{15}i$

Question Number : 51 Question Id : 40503611881 Question Type : MCQ Option Shuffling : Yes
 Display Question Number : Yes Is Question Mandatory : No Single Line Question Option : No Option
 Orientation : Vertical
 Correct Marks : 4 Wrong Marks : 1

$\left(\frac{-1+i\sqrt{3}}{1-i}\right)^{30}$ का मान है :

Options :

40503642986. 6^5

40503642987. -2^{15}

40503642988. $2^{15}i$

40503642989. $-2^{15}i$

Question Number : 52 Question Id : 40503611882 Question Type : MCQ Option Shuffling : Yes Display Question Number : Yes Is Question Mandatory : No Single Line Question Option : No Option Orientation : Vertical

Correct Marks : 4 Wrong Marks : 1

If α and β are the roots of the equation, $7x^2 - 3x - 2 = 0$, then the value of

$\frac{\alpha}{1-\alpha^2} + \frac{\beta}{1-\beta^2}$ is equal to :

Options :

40503642990. $\frac{1}{24}$

40503642991. $\frac{27}{16}$

40503642992. $\frac{3}{8}$

40503642993. $\frac{27}{32}$

Question Number : 52 Question Id : 40503611882 Question Type : MCQ Option Shuffling : Yes Display Question Number : Yes Is Question Mandatory : No Single Line Question Option : No Option Orientation : Vertical

Correct Marks : 4 Wrong Marks : 1

यदि α तथा β समीकरण $7x^2 - 3x - 2 = 0$ के मूल

हैं, तो $\frac{\alpha}{1-\alpha^2} + \frac{\beta}{1-\beta^2}$ का मान है :

Options :

40503642990. $\frac{1}{24}$

40503642991. $\frac{27}{16}$

40503642992. $\frac{3}{8}$

40503642993. $\frac{27}{32}$

Question Number : 53 Question Id : 40503611883 Question Type : MCQ Option Shuffling : Yes Display Question Number : Yes Is Question Mandatory : No Single Line Question Option : No Option Orientation : Vertical

Correct Marks : 4 Wrong Marks : 1

If $a + x = b + y = c + z + 1$, where a, b, c, x, y, z are non-zero distinct real numbers,

then $\begin{vmatrix} x & a+y & x+a \\ y & b+y & y+b \\ z & c+y & z+c \end{vmatrix}$ is equal to :

Options :

40503642994. $y(b - a)$

40503642995. $y(a - b)$

40503642996. 0

40503642997. $y(a - c)$

Question Number : 53 Question Id : 40503611883 Question Type : MCQ Option Shuffling : Yes Display Question Number : Yes Is Question Mandatory : No Single Line Question Option : No Option Orientation : Vertical

Correct Marks : 4 Wrong Marks : 1

यदि $a+x=b+y=c+z+1$ है, जहाँ a, b, c, x, y, z शून्येत्तर भिन्न वास्तविक संख्याएँ हैं, तो

$$\begin{vmatrix} x & a+y & x+a \\ y & b+y & y+b \\ z & c+y & z+c \end{vmatrix} \text{ बराबर है :}$$

Options :

40503642994. $y(b-a)$

40503642995. $y(a-b)$

40503642996. 0

40503642997. $y(a-c)$

Question Number : 54 Question Id : 40503611884 Question Type : MCQ Option Shuffling : Yes Display Question Number : Yes Is Question Mandatory : No Single Line Question Option : No Option Orientation : Vertical

Correct Marks : 4 Wrong Marks : 1

If the system of linear equations

$$x + y + 3z = 0$$

$$x + 3y + k^2z = 0$$

$$3x + y + 3z = 0$$

has a non-zero solution (x, y, z) for some

$k \in \mathbb{R}$, then $x + \left(\frac{y}{z}\right)$ is equal to :

Options :

40503642998. 3

40503642999. -3

40503643000. 9

40503643001. -9

Question Number : 54 Question Id : 40503611884 Question Type : MCQ Option Shuffling : Yes Display Question Number : Yes Is Question Mandatory : No Single Line Question Option : No Option

Orientation : Vertical

Correct Marks : 4 Wrong Marks : 1

यदि रेखिक समीकरण निकाय

$$x + y + 3z = 0$$

$$x + 3y + k^2z = 0$$

$$3x + y + 3z = 0$$

का, किसी $k \in \mathbb{R}$, के लिए, एक शून्येत्तर हल

(x, y, z) है, तो $x + \left(\frac{y}{z}\right)$ बराबर है :

Options :

40503642998. 3

40503642999. -3

40503643000. 9

40503643001. -9

Question Number : 55 Question Id : 40503611885 Question Type : MCQ Option Shuffling : Yes
Display Question Number : Yes Is Question Mandatory : No Single Line Question Option : No Option
Orientation : Vertical

Correct Marks : 4 Wrong Marks : 1

There are 3 sections in a question paper and each section contains 5 questions. A candidate has to answer a total of 5 questions, choosing at least one question from each section. Then the number of ways, in which the candidate can choose the questions, is :

Options :

40503643002. 1500

40503643003. 3000

40503643004. 2255

40503643005. 2250

Question Number : 55 Question Id : 40503611885 Question Type : MCQ Option Shuffling : Yes
Display Question Number : Yes Is Question Mandatory : No Single Line Question Option : No Option
Orientation : Vertical

Correct Marks : 4 Wrong Marks : 1

एक प्रश्नपत्र में 3 खण्ड हैं तथा प्रत्येक खण्ड में 5 प्रश्न हैं। एक परीक्षार्थी को प्रत्येक खण्ड में से कम से कम एक प्रश्न चुनकर कुल 5 प्रश्नों के उत्तर देने हैं, तो परीक्षार्थी द्वारा इन प्रश्नों को चुनने के तरीकों की संख्या है :

Options :

40503643002. 1500

40503643003. 3000

40503643004. 2255

40503643005. 2250

Question Number : 56 Question Id : 40503611886 Question Type : MCQ Option Shuffling : Yes
Display Question Number : Yes Is Question Mandatory : No Single Line Question Option : No Option
Orientation : Vertical

Correct Marks : 4 Wrong Marks : 1

If the sum of the second, third and fourth terms of a positive term G.P. is 3 and the sum of its sixth, seventh and eighth terms is 243, then the sum of the first 50 terms of this G.P. is :

Options :

40503643006. $\frac{1}{26}(3^{50} - 1)$

40503643007. $\frac{1}{13}(3^{50} - 1)$

40503643008. $\frac{2}{13}(3^{50} - 1)$

40503643009. $\frac{1}{26}(3^{49} - 1)$

Question Number : 56 Question Id : 40503611886 Question Type : MCQ Option Shuffling : Yes Display Question Number : Yes Is Question Mandatory : No Single Line Question Option : No Option Orientation : Vertical

Correct Marks : 4 Wrong Marks : 1

यदि धनात्मक पदों की एक गुणोत्तर श्रेणी के दूसरे, तीसरे तथा चौथे पदों का योगफल 3 है तथा इसके छठे, सातवें और आठवें पदों का योगफल 243 है, तो इस गुणोत्तर श्रेणी के प्रथम 50 पदों का योगफल है :

Options :

40503643006. $\frac{1}{26}(3^{50} - 1)$

40503643007. $\frac{1}{13}(3^{50} - 1)$

40503643008. $\frac{2}{13}(3^{50} - 1)$

40503643009. $\frac{1}{26}(3^{49} - 1)$

Question Number : 57 Question Id : 40503611887 Question Type : MCQ Option Shuffling : Yes Display Question Number : Yes Is Question Mandatory : No Single Line Question Option : No Option Orientation : Vertical

Correct Marks : 4 Wrong Marks : 1

If the sum of the first 20 terms of the series

$$\log_{(7^{1/2})} x + \log_{(7^{1/3})} x + \log_{(7^{1/4})} x + \dots \text{ is}$$

460, then x is equal to :

Options :

40503643010. e^2

40503643011. $7^{1/2}$

40503643012. 7^2

40503643013. ^{746/21}

Question Number : 57 Question Id : 40503611887 Question Type : MCQ Option Shuffling : Yes Display Question Number : Yes Is Question Mandatory : No Single Line Question Option : No Option Orientation : Vertical

Correct Marks : 4 Wrong Marks : 1

यदि श्रेणी

$\log_{(7^{1/2})} x + \log_{(7^{1/3})} x + \log_{(7^{1/4})} x + \dots$ के

प्रथम 20 पदों का योगफल 460 है, तो x बराबर है :

Options :

40503643010. e^2

40503643011. $7^{1/2}$

40503643012. 7^2

40503643013. ^{746/21}

Question Number : 58 Question Id : 40503611888 Question Type : MCQ Option Shuffling : Yes Display Question Number : Yes Is Question Mandatory : No Single Line Question Option : No Option Orientation : Vertical

Correct Marks : 4 Wrong Marks : 1

$$\lim_{x \rightarrow 0} \frac{x \left(e^{\left(\frac{\sqrt{1+x^2+x^4}-1}{x} - 1 \right)} \right)}{\sqrt{1+x^2+x^4}-1}$$

Options :

40503643014. does not exist.

40503643015. is equal to 1.

40503643016. is equal to 0.

40503643017. is equal to \sqrt{e} .

Question Number : 58 Question Id : 40503611888 Question Type : MCQ Option Shuffling : Yes Display Question Number : Yes Is Question Mandatory : No Single Line Question Option : No Option

Orientation : Vertical

Correct Marks : 4 Wrong Marks : 1

$$\lim_{x \rightarrow 0} \frac{x \left(e^{(\sqrt{1+x^2+x^4}-1)/x} - 1 \right)}{\sqrt{1+x^2+x^4}-1}$$

Options :

40503643014. का अस्तित्व नहीं है।

40503643015. 1 के बराबर है।

40503643016. 0 के बराबर है।

40503643017. \sqrt{e} के बराबर है।

Question Number : 59 Question Id : 40503611889 Question Type : MCQ Option Shuffling : Yes Display Question Number : Yes Is Question Mandatory : No Single Line Question Option : No Option Orientation : Vertical

Correct Marks : 4 Wrong Marks : 1

The derivative of $\tan^{-1}\left(\frac{\sqrt{1+x^2}-1}{x}\right)$ with

respect to $\tan^{-1}\left(\frac{2x\sqrt{1-x^2}}{1-2x^2}\right)$ at $x=\frac{1}{2}$ is :

Options :

40503643018. $\frac{2\sqrt{3}}{3}$

40503643019. $\frac{\sqrt{3}}{12}$

40503643020. $\frac{\sqrt{3}}{10}$

40503643021. $\frac{2\sqrt{3}}{5}$

Question Number : 59 Question Id : 40503611889 Question Type : MCQ Option Shuffling : Yes
 Display Question Number : Yes Is Question Mandatory : No Single Line Question Option : No Option
 Orientation : Vertical

Correct Marks : 4 Wrong Marks : 1

$$x = \frac{1}{2} \text{ पर } \tan^{-1}\left(\frac{\sqrt{1+x^2}-1}{x}\right) \text{ का}$$

$$\tan^{-1}\left(\frac{2x\sqrt{1-x^2}}{1-2x^2}\right) \text{ के सापेक्ष अवकलज है :}$$

Options :

40503643018. $\frac{2\sqrt{3}}{3}$

40503643019. $\frac{\sqrt{3}}{12}$

40503643020. $\frac{\sqrt{3}}{10}$

40503643021. $\frac{2\sqrt{3}}{5}$

Question Number : 60 Question Id : 40503611890 Question Type : MCQ Option Shuffling : Yes
 Display Question Number : Yes Is Question Mandatory : No Single Line Question Option : No Option
 Orientation : Vertical

Correct Marks : 4 Wrong Marks : 1

Which of the following points lies on the
 tangent to the curve $x^4e^y + 2\sqrt{y+1} = 3$ at
 the point (1, 0) ?

Options :

40503643022. (-2, 4)

40503643023. (2, 6)

40503643024. (2, 2)

40503643025. $(-2, 6)$

Question Number : 60 Question Id : 40503611890 Question Type : MCQ Option Shuffling : Yes Display Question Number : Yes Is Question Mandatory : No Single Line Question Option : No Option Orientation : Vertical

Correct Marks : 4 Wrong Marks : 1

निम्न में से कौन सा बिंदु वक्र $x^4 e^y + 2\sqrt{y+1} = 3$ के बिंदु $(1, 0)$ पर खींची गई स्पर्श रेखा पर स्थित है?

Options :

40503643022. $(-2, 4)$

40503643023. $(2, 6)$

40503643024. $(2, 2)$

40503643025. $(-2, 6)$

Question Number : 61 Question Id : 40503611891 Question Type : MCQ Option Shuffling : Yes Display Question Number : Yes Is Question Mandatory : No Single Line Question Option : No Option Orientation : Vertical

Correct Marks : 4 Wrong Marks : 1

If $x=1$ is a critical point of the function

$f(x) = (3x^2 + ax - 2 - a)e^x$, then :

Options :

$x=1$ and $x = -\frac{2}{3}$ are local minima

40503643026. of f .

$x=1$ and $x = -\frac{2}{3}$ are local maxima

40503643027. of f .

$x=1$ is a local maxima and $x = -\frac{2}{3}$

40503643028. is a local minima of f .

$x=1$ is a local minima and $x = -\frac{2}{3}$

is a local maxima of f .
40503643029.

Question Number : 61 Question Id : 40503611891 Question Type : MCQ Option Shuffling : Yes Display Question Number : Yes Is Question Mandatory : No Single Line Question Option : No Option Orientation : Vertical

Correct Marks : 4 Wrong Marks : 1

यदि $x=1$ फलन $f(x) = (3x^2 + ax - 2 - a) e^x$
का एक क्रांतिक बिंदु (critical point) है, तो :

Options :

$x=1$ तथा $x = -\frac{2}{3}$, f के स्थानीय
निम्नतम बिंदु हैं।
40503643026.

$x=1$ तथा $x = -\frac{2}{3}$, f के स्थानीय उच्चतम
बिंदु है।
40503643027.

$x=1$, f का एक स्थानीय उच्चतम बिंदु है तथा
 $x = -\frac{2}{3}$, f का एक स्थानीय निम्नतम बिंदु है।
40503643028.

$x=1$, f का एक स्थानीय निम्नतम बिंदु है तथा
 $x = -\frac{2}{3}$, f का एक स्थानीय उच्चतम बिंदु है।
40503643029.

Question Number : 62 Question Id : 40503611892 Question Type : MCQ Option Shuffling : Yes Display Question Number : Yes Is Question Mandatory : No Single Line Question Option : No Option Orientation : Vertical

Correct Marks : 4 Wrong Marks : 1

If $\int \frac{\cos\theta}{5+7\sin\theta-2\cos^2\theta} d\theta = A \log_e |B(\theta)| + C$,

where C is a constant of integration, then

$\frac{B(\theta)}{A}$ can be :

Options :

40503643030. $\frac{2 \sin \theta + 1}{5(\sin \theta + 3)}$

40503643031. $\frac{5(2 \sin \theta + 1)}{\sin \theta + 3}$

40503643032. $\frac{2 \sin \theta + 1}{\sin \theta + 3}$

40503643033. $\frac{5(\sin \theta + 3)}{2 \sin \theta + 1}$

Question Number : 62 Question Id : 40503611892 Question Type : MCQ Option Shuffling : Yes Display Question Number : Yes Is Question Mandatory : No Single Line Question Option : No Option Orientation : Vertical

Correct Marks : 4 Wrong Marks : 1

यदि $\int \frac{\cos \theta}{5 + 7 \sin \theta - 2 \cos^2 \theta} d\theta = A \log_e |B(\theta)| + C$

है, जहाँ C एक समाकलन अचर है, तो $\frac{B(\theta)}{A}$ हो

सकता है :

Options :

40503643030. $\frac{2 \sin \theta + 1}{5(\sin \theta + 3)}$

40503643031. $\frac{5(2 \sin \theta + 1)}{\sin \theta + 3}$

40503643032. $\frac{2 \sin \theta + 1}{\sin \theta + 3}$

40503643033. $\frac{5(\sin \theta + 3)}{2 \sin \theta + 1}$

Question Number : 63 Question Id : 40503611893 Question Type : MCQ Option Shuffling : Yes Display Question Number : Yes Is Question Mandatory : No Single Line Question Option : No Option Orientation : Vertical

Correct Marks : 4 Wrong Marks : 1

The area (in sq. units) of the region

$$A = \{(x, y) : (x-1)[x] \leq y \leq 2\sqrt{x}, 0 \leq x \leq 2\},$$

where $[t]$ denotes the greatest integer function, is :

Options :

40503643034. $\frac{4}{3}\sqrt{2} - \frac{1}{2}$

40503643035. $\frac{8}{3}\sqrt{2} - 1$

40503643036. $\frac{4}{3}\sqrt{2} + 1$

40503643037. $\frac{8}{3}\sqrt{2} - \frac{1}{2}$

Question Number : 63 Question Id : 40503611893 Question Type : MCQ Option Shuffling : Yes
Display Question Number : Yes Is Question Mandatory : No Single Line Question Option : No Option
Orientation : Vertical

Correct Marks : 4 Wrong Marks : 1

क्षेत्र $A = \{(x, y) : (x-1)[x] \leq y \leq 2\sqrt{x}, 0 \leq x \leq 2\}$

जहाँ $[t]$ महत्तम पूर्णांक फलन है, का क्षेत्रफल (वर्ग इकाइयों में) है :

Options :

40503643034. $\frac{4}{3}\sqrt{2} - \frac{1}{2}$

40503643035. $\frac{8}{3}\sqrt{2} - 1$

40503643036. $\frac{4}{3}\sqrt{2} + 1$

40503643037. $\frac{8}{3}\sqrt{2} - \frac{1}{2}$

Question Number : 64 Question Id : 40503611894 Question Type : MCQ Option Shuffling : Yes
 Display Question Number : Yes Is Question Mandatory : No Single Line Question Option : No Option
 Orientation : Vertical

Correct Marks : 4 Wrong Marks : 1

Let $y = y(x)$ be the solution of the differential equation

$$\cos x \frac{dy}{dx} + 2y \sin x = \sin 2x, x \in \left(0, \frac{\pi}{2}\right).$$

If $y(\pi/3) = 0$, then $y(\pi/4)$ is equal to :

Options :

40503643038. $2 - \sqrt{2}$

40503643039. $\sqrt{2} - 2$

40503643040. $2 + \sqrt{2}$

40503643041. $\frac{1}{\sqrt{2}} - 1$

Question Number : 64 Question Id : 40503611894 Question Type : MCQ Option Shuffling : Yes
 Display Question Number : Yes Is Question Mandatory : No Single Line Question Option : No Option
 Orientation : Vertical

Correct Marks : 4 Wrong Marks : 1

माना $y = y(x)$, अवकल समीकरण

$$\cos x \frac{dy}{dx} + 2y \sin x = \sin 2x, x \in \left(0, \frac{\pi}{2}\right) \text{ का हल}$$

है। यदि $y(\pi/3) = 0$ है तो $y(\pi/4)$ बराबर है :

Options :

40503643038. $2 - \sqrt{2}$

40503643039. $\sqrt{2} - 2$

40503643040. $2 + \sqrt{2}$

40503643041. $\frac{1}{\sqrt{2}} - 1$

Question Number : 65 Question Id : 40503611895 Question Type : MCQ Option Shuffling : Yes
Display Question Number : Yes Is Question Mandatory : No Single Line Question Option : No Option
Orientation : Vertical

Correct Marks : 4 Wrong Marks : 1

If the length of the chord of the circle,
 $x^2 + y^2 = r^2$ ($r > 0$) along the line, $y - 2x = 3$
is r , then r^2 is equal to :

Options :

40503643042. $\frac{9}{5}$

40503643043. $\frac{12}{5}$

40503643044. $\frac{24}{5}$

40503643045. 12

Question Number : 65 Question Id : 40503611895 Question Type : MCQ Option Shuffling : Yes
Display Question Number : Yes Is Question Mandatory : No Single Line Question Option : No Option
Orientation : Vertical

Correct Marks : 4 Wrong Marks : 1

यदि वृत्त $x^2 + y^2 = r^2$ ($r > 0$) की, रेखा $y - 2x = 3$
के अनुदिश, जीवा की लंबाई r है, तो r^2 बराबर है :

Options :

40503643042. $\frac{9}{5}$

40503643043. $\frac{12}{5}$

40503643044. $\frac{24}{5}$

40503643045. 12

Question Number : 66 Question Id : 40503611896 Question Type : MCQ Option Shuffling : Yes
Display Question Number : Yes Is Question Mandatory : No Single Line Question Option : No Option
Orientation : Vertical
Correct Marks : 4 Wrong Marks : 1

If the line $y = mx + c$ is a common tangent

to the hyperbola $\frac{x^2}{100} - \frac{y^2}{64} = 1$ and the
circle $x^2 + y^2 = 36$, then which one of the
following is true ?

Options :

40503643046. $8m + 5 = 0$

40503643047. $5m = 4$

40503643048. $4c^2 = 369$

40503643049. $c^2 = 369$

Question Number : 66 Question Id : 40503611896 Question Type : MCQ Option Shuffling : Yes
Display Question Number : Yes Is Question Mandatory : No Single Line Question Option : No Option
Orientation : Vertical
Correct Marks : 4 Wrong Marks : 1

यदि रेखा $y = mx + c$ अतिपरवलय

$\frac{x^2}{100} - \frac{y^2}{64} = 1$ तथा वृत्त $x^2 + y^2 = 36$ की एक

उभयनिष्ठ स्पर्श रेखा है, तो निम्न में से कौन सा एक
सही है ?

Options :

40503643046. $8m + 5 = 0$

40503643047. $5m = 4$

40503643048. $4c^2 = 369$

40503643049. $c^2 = 369$

Question Number : 67 Question Id : 40503611897 Question Type : MCQ Option Shuffling : Yes
 Display Question Number : Yes Is Question Mandatory : No Single Line Question Option : No Option
 Orientation : Vertical

Correct Marks : 4 Wrong Marks : 1

If for some $\alpha \in \mathbb{R}$, the lines

$$L_1 : \frac{x+1}{2} = \frac{y-2}{-1} = \frac{z-1}{1} \text{ and}$$

$$L_2 : \frac{x+2}{\alpha} = \frac{y+1}{5-\alpha} = \frac{z+1}{1} \text{ are coplanar,}$$

then the line L_2 passes through the point :

Options :

40503643050. $(10, -2, -2)$

40503643051. $(10, 2, 2)$

40503643052. $(2, -10, -2)$

40503643053. $(-2, 10, 2)$

Question Number : 67 Question Id : 40503611897 Question Type : MCQ Option Shuffling : Yes
 Display Question Number : Yes Is Question Mandatory : No Single Line Question Option : No Option
 Orientation : Vertical

Correct Marks : 4 Wrong Marks : 1

यदि किसी $\alpha \in \mathbb{R}$ के लिए, रेखाएँ

$$L_1 : \frac{x+1}{2} = \frac{y-2}{-1} = \frac{z-1}{1} \text{ तथा}$$

$$L_2 : \frac{x+2}{\alpha} = \frac{y+1}{5-\alpha} = \frac{z+1}{1} \text{ समतलीय हैं, तो रेखा}$$

L_2 जिस बिंदु से होकर जाती है, वह है :

Options :

40503643050. $(10, -2, -2)$

40503643051. $(10, 2, 2)$

40503643052. $(2, -10, -2)$

40503643053. $(-2, 10, 2)$

Question Number : 68 Question Id : 40503611898 Question Type : MCQ Option Shuffling : Yes Display Question Number : Yes Is Question Mandatory : No Single Line Question Option : No Option Orientation : Vertical

Correct Marks : 4 Wrong Marks : 1

If the mean and the standard deviation of the data 3, 5, 7, a, b are 5 and 2 respectively, then a and b are the roots of the equation :

Options :

40503643054. $x^2 - 10x + 18 = 0$

40503643055. $x^2 - 10x + 19 = 0$

40503643056. $x^2 - 20x + 18 = 0$

40503643057. $2x^2 - 20x + 19 = 0$

Question Number : 68 Question Id : 40503611898 Question Type : MCQ Option Shuffling : Yes Display Question Number : Yes Is Question Mandatory : No Single Line Question Option : No Option Orientation : Vertical

Correct Marks : 4 Wrong Marks : 1

यदि आँकड़ों 3, 5, 7, a, b का माध्य तथा मानक विचलन क्रमशः 5 तथा 2 हैं, तो a तथा b जिस समीकरण के मूल हैं, वह है :

Options :

40503643054. $x^2 - 10x + 18 = 0$

40503643055. $x^2 - 10x + 19 = 0$

40503643056. $x^2 - 20x + 18 = 0$

40503643057. $2x^2 - 20x + 19 = 0$

Question Number : 69 Question Id : 40503611899 Question Type : MCQ Option Shuffling : Yes
 Display Question Number : Yes Is Question Mandatory : No Single Line Question Option : No Option
 Orientation : Vertical

Correct Marks : 4 Wrong Marks : 1

If $L = \sin^2\left(\frac{\pi}{16}\right) - \sin^2\left(\frac{\pi}{8}\right)$ and

$M = \cos^2\left(\frac{\pi}{16}\right) - \sin^2\left(\frac{\pi}{8}\right)$, then :

Options :

40503643058. $L = -\frac{1}{2\sqrt{2}} + \frac{1}{2}\cos\frac{\pi}{8}$

40503643059. $L = \frac{1}{4\sqrt{2}} - \frac{1}{4}\cos\frac{\pi}{8}$

40503643060. $M = \frac{1}{2\sqrt{2}} + \frac{1}{2}\cos\frac{\pi}{8}$

40503643061. $M = \frac{1}{4\sqrt{2}} + \frac{1}{4}\cos\frac{\pi}{8}$

Question Number : 69 Question Id : 40503611899 Question Type : MCQ Option Shuffling : Yes
 Display Question Number : Yes Is Question Mandatory : No Single Line Question Option : No Option
 Orientation : Vertical

Correct Marks : 4 Wrong Marks : 1

यदि $L = \sin^2\left(\frac{\pi}{16}\right) - \sin^2\left(\frac{\pi}{8}\right)$ तथा

$M = \cos^2\left(\frac{\pi}{16}\right) - \sin^2\left(\frac{\pi}{8}\right)$ हैं, तो :

Options :

40503643058. $L = -\frac{1}{2\sqrt{2}} + \frac{1}{2}\cos\frac{\pi}{8}$

40503643059. $L = \frac{1}{4\sqrt{2}} - \frac{1}{4}\cos\frac{\pi}{8}$

40503643060. $M = \frac{1}{2\sqrt{2}} + \frac{1}{2} \cos \frac{\pi}{8}$

40503643061. $M = \frac{1}{4\sqrt{2}} + \frac{1}{4} \cos \frac{\pi}{8}$

Question Number : 70 Question Id : 40503611900 Question Type : MCQ Option Shuffling : Yes Display Question Number : Yes Is Question Mandatory : No Single Line Question Option : No Option Orientation : Vertical

Correct Marks : 4 Wrong Marks : 1

The statement

$(p \rightarrow (q \rightarrow p)) \rightarrow (p \rightarrow (p \vee q))$ is :

Options :

40503643062. a contradiction

40503643063. a tautology

40503643064. equivalent to $(p \vee q) \wedge (\sim p)$

40503643065. equivalent to $(p \wedge q) \vee (\sim q)$

Question Number : 70 Question Id : 40503611900 Question Type : MCQ Option Shuffling : Yes Display Question Number : Yes Is Question Mandatory : No Single Line Question Option : No Option Orientation : Vertical

Correct Marks : 4 Wrong Marks : 1

कथन $(p \rightarrow (q \rightarrow p)) \rightarrow (p \rightarrow (p \vee q))$:

Options :

40503643062. एक विरोधोक्ति है।

40503643063. एक पुनरुक्ति है।

40503643064. $(p \vee q) \wedge (\sim p)$ के समतुल्य है।

40503643065. $(p \wedge q) \vee (\sim q)$ के समतुल्य है।

Sub-Section Id :

405036838

Question Shuffling Allowed :

Yes

Question Number : 71 Question Id : 40503611901 Question Type : SA Display Question Number : Yes
Correct Marks : 4 Wrong Marks : 0

Let $A = \{a, b, c\}$ and $B = \{1, 2, 3, 4\}$. Then the number of elements in the set $C = \{f : A \rightarrow B \mid 2 \in f(A) \text{ and } f \text{ is not one-one}\}$ is _____.

Response Type : Numeric

Evaluation Required For SA : Yes

Show Word Count : Yes

Answers Type : Range

Text Areas : PlainText

Possible Answers :

5 to 5.002

Question Number : 71 Question Id : 40503611901 Question Type : SA Display Question Number : Yes
Correct Marks : 4 Wrong Marks : 0

माना $A = \{a, b, c\}$ तथा $B = \{1, 2, 3, 4\}$ हैं, तो समुच्चय $C = \{f : A \rightarrow B \mid 2 \in f(A) \text{ तथा } f \text{ एकैकी नहीं है}\}$ के अवयवों की संख्या है _____।

Response Type : Numeric

Evaluation Required For SA : Yes

Show Word Count : Yes

Answers Type : Range

Text Areas : PlainText

Possible Answers :

5 to 5.002

Question Number : 72 Question Id : 40503611902 Question Type : SA Display Question Number : Yes
Correct Marks : 4 Wrong Marks : 0

The coefficient of x^4 in the expansion of $(1 + x + x^2 + x^3)^6$ in powers of x , is _____.

Response Type : Numeric

Evaluation Required For SA : Yes

Show Word Count : Yes

Answers Type : Range

Text Areas : PlainText

Possible Answers :

5 to 5.002

Question Number : 72 Question Id : 40503611902 Question Type : SA Display Question Number : Yes
Correct Marks : 4 Wrong Marks : 0

x की घातों में $(1+x+x^2+x^3)^6$ के प्रसार में x^4 का गुणांक है _____।

Response Type : Numeric

Evaluation Required For SA : Yes

Show Word Count : Yes

Answers Type : Range

Text Areas : PlainText

Possible Answers :

5 to 5.002

Question Number : 73 Question Id : 40503611903 Question Type : SA Display Question Number : Yes
Correct Marks : 4 Wrong Marks : 0

If the lines $x+y=a$ and $x-y=b$ touch the curve $y=x^2-3x+2$ at the points where the

curve intersects the x -axis, then $\frac{a}{b}$ is equal

to _____.

Response Type : Numeric

Evaluation Required For SA : Yes

Show Word Count : Yes

Answers Type : Range

Text Areas : PlainText

Possible Answers :

5 to 5.002

Question Number : 73 Question Id : 40503611903 Question Type : SA Display Question Number : Yes
Correct Marks : 4 Wrong Marks : 0

यदि रेखाएँ $x+y=a$ तथा $x-y=b$, वक्र $y=x^2-3x+2$ को उन बिन्दुओं पर स्पर्श करती हैं

जहाँ यह वक्र x -अक्ष को काटता है, तो $\frac{a}{b}$ बराबर

है _____।

Response Type : Numeric

Evaluation Required For SA : Yes

Show Word Count : Yes

Answers Type : Range

Text Areas : PlainText

Possible Answers :

5 to 5.002

Question Number : 74 Question Id : 40503611904 Question Type : SA Display Question Number : Yes

Correct Marks : 4 Wrong Marks : 0

Let the vectors \vec{a} , \vec{b} , \vec{c} be such that

$|\vec{a}|=2$, $|\vec{b}|=4$ and $|\vec{c}|=4$. If the

projection of \vec{b} on \vec{a} is equal to the

projection of \vec{c} on \vec{a} and \vec{b} is

perpendicular to \vec{c} , then the value of

$|\vec{a} + \vec{b} - \vec{c}|$ is _____.

Response Type : Numeric

Evaluation Required For SA : Yes

Show Word Count : Yes

Answers Type : Range

Text Areas : PlainText

Possible Answers :

5 to 5.002

Question Number : 74 Question Id : 40503611904 Question Type : SA Display Question Number : Yes

Correct Marks : 4 Wrong Marks : 0

माना सदिश \vec{a} , \vec{b} , \vec{c} इस प्रकार हैं कि

$|\vec{a}|=2$, $|\vec{b}|=4$ तथा $|\vec{c}|=4$ हैं। यदि \vec{b} का

\vec{a} पर प्रक्षेप, \vec{c} के \vec{a} पर प्रक्षेप के समान है तथा

\vec{b} और \vec{c} परस्पर लंबवत हैं तो $|\vec{a} + \vec{b} - \vec{c}|$

का मान है _____।

Response Type : Numeric

Evaluation Required For SA : Yes

Show Word Count : Yes

Answers Type : Range

Text Areas : PlainText

Possible Answers :

5 to 5.002

Question Number : 75 Question Id : 40503611905 Question Type : SA Display Question Number : Yes

Correct Marks : 4 Wrong Marks : 0

In a bombing attack, there is 50% chance that a bomb will hit the target. At least two independent hits are required to destroy the target completely. Then the minimum number of bombs, that must be dropped to ensure that there is at least 99% chance of completely destroying the target, is _____.

Response Type : Numeric

Evaluation Required For SA : Yes

Show Word Count : Yes

Answers Type : Range

Text Areas : PlainText

Possible Answers :

5 to 5.002

Question Number : 75 Question Id : 40503611905 Question Type : SA Display Question Number : Yes

Correct Marks : 4 Wrong Marks : 0

बमों के एक आक्रमण में, एक बम के लक्ष्य पर प्रहार करने की संभावना 50% है। लक्ष्य को पूरी तरह से नष्ट करने के लिए कम से कम दो स्वतंत्र प्रहारों की आवश्यकता है, तो लक्ष्य को पूरी तरह से नष्ट करने की संभावना कम से कम 99% सुनिश्चित करने के लिए गिराए जाने वाले बमों की न्यूनतम संख्या है _____।

Response Type : Numeric

Evaluation Required For SA : Yes

Show Word Count : Yes

Answers Type : Range

Text Areas : PlainText

Possible Answers :

5 to 5.002