

Question Paper Name: BTECH 9th Jan 2020 Shift 2
Subject Name: BTECH
Creation Date: 2020-01-09 18:52:48
Duration: 180
Total Marks: 300
Display Marks: Yes

BTECH

Group Number : 1
Group Id : 40503627
Group Maximum Duration : 0
Group Minimum Duration : 180
Show Attended Group? : No
Edit Attended Group? : No
Break time: 0
Group Marks: 300
Is this Group for Examiner?: No

Physics

Section Id : 40503684
Section Number : 1
Section type : Online
Mandatory or Optional: Mandatory
Number of Questions: 25
Number of Questions to be attempted: 25
Section Marks: 100

Sub-Section Number: 1
Sub-Section Id: 405036140
Question Shuffling Allowed : Yes

Question Number : 1 Question Type : MCQ Option Shuffling : Yes
Correct Marks : 4 Wrong Marks : 1

For the four sets of three measured physical quantities as given below. Which of the following options is correct ?

- (i) $A_1 = 24.36, B_1 = 0.0724, C_1 = 256.2$
- (ii) $A_2 = 24.44, B_2 = 16.082, C_2 = 240.2$
- (iii) $A_3 = 25.2, B_3 = 19.2812, C_3 = 236.183$
- (iv) $A_4 = 25, B_4 = 236.191, C_4 = 19.5$

Note: For this question, discrepancy is found in question/answer. Full Marks is being awarded to all candidates.

Options :

$$1. \quad A_1 + B_1 + C_1 < A_3 + B_3 + C_3 < A_2 + B_2 + C_2 < A_4 + B_4 + C_4$$

$$2. \quad A_1 + B_1 + C_1 = A_2 + B_2 + C_2 = A_3 + B_3 + C_3 = A_4 + B_4 + C_4$$

$$3. \quad A_4 + B_4 + C_4 < A_1 + B_1 + C_1 = A_2 + B_2 + C_2 = A_3 + B_3 + C_3$$

$$4. \quad A_4 + B_4 + C_4 < A_1 + B_1 + C_1 < A_3 + B_3 + C_3 < A_2 + B_2 + C_2$$

Question Number : 1 Question Type : MCQ Option Shuffling : Yes

Correct Marks : 4 Wrong Marks : 1

तीन भौतिक राशियों की माप के नीचे दिये गये चार समुच्चयों के लिये निम्नलिखित विकल्पों में से कौन सा सही है ?

- (i) $A_1 = 24.36, B_1 = 0.0724, C_1 = 256.2$
- (ii) $A_2 = 24.44, B_2 = 16.082, C_2 = 240.2$
- (iii) $A_3 = 25.2, B_3 = 19.2812, C_3 = 236.183$
- (iv) $A_4 = 25, B_4 = 236.191, C_4 = 19.5$

Note: For this question, discrepancy is found in question/answer. Full Marks is being awarded to all candidates.

Options :

1. $A_1 + B_1 + C_1 < A_3 + B_3 + C_3 <$
 $A_2 + B_2 + C_2 < A_4 + B_4 + C_4$

2. $A_1 + B_1 + C_1 = A_2 + B_2 + C_2 =$
 $A_3 + B_3 + C_3 = A_4 + B_4 + C_4$

3. $A_4 + B_4 + C_4 < A_1 + B_1 + C_1 =$
 $A_2 + B_2 + C_2 = A_3 + B_3 + C_3$

4. $A_4 + B_4 + C_4 < A_1 + B_1 + C_1 <$
 $A_3 + B_3 + C_3 < A_2 + B_2 + C_2$

Question Number : 1 Question Type : MCQ Option Shuffling : Yes

Correct Marks : 4 Wrong Marks : 1

ચાર સેટ (અવલોકનો) માટે મપાયેલ ત્રણ ભૌતિકશાસ્ત્રિઓ
માટે નીચેનાંમાંથી કયું સાચું છે?

(i) $A_1 = 24.36, B_1 = 0.0724, C_1 = 256.2$

(ii) $A_2 = 24.44, B_2 = 16.082, C_2 = 240.2$

(iii) $A_3 = 25.2, B_3 = 19.2812, C_3 = 236.183$

(iv) $A_4 = 25, B_4 = 236.191, C_4 = 19.5$

Note: For this question, discrepancy is found in question/answer. Full Marks is being awarded to all candidates.

Options :

1. $A_1 + B_1 + C_1 < A_3 + B_3 + C_3 <$
 $A_2 + B_2 + C_2 < A_4 + B_4 + C_4$

2. $A_1 + B_1 + C_1 = A_2 + B_2 + C_2 =$
 $A_3 + B_3 + C_3 = A_4 + B_4 + C_4$

$$A_4 + B_4 + C_4 < A_1 + B_1 + C_1 =$$

$$3. A_2 + B_2 + C_2 = A_3 + B_3 + C_3$$

$$A_4 + B_4 + C_4 < A_1 + B_1 + C_1 <$$

$$4. A_3 + B_3 + C_3 < A_2 + B_2 + C_2$$

Question Number : 2 Question Type : MCQ Option Shuffling : Yes

Correct Marks : 4 Wrong Marks : 1

A particle starts from the origin at $t=0$ with

an initial velocity of $3.0\hat{i}$ m/s and moves in the x - y plane with a constant acceleration

$(6.0\hat{i} + 4.0\hat{j})$ m/s². The x -coordinate of the particle at the instant when its y -coordinate is 32 m is D meters. The value of D is :

Options :

1. 50

2. 32

3. 60

4. 40

Question Number : 2 Question Type : MCQ Option Shuffling : Yes

Correct Marks : 4 Wrong Marks : 1

एक कण समय $t=0$ पर मूल बिन्दु से प्रारम्भिक वेग

$3.0\hat{i}$ m/s और त्वरण $(6.0\hat{i} + 4.0\hat{j})$ m/s² से

चलना शुरू करते हुए x - y समतल में चलता है। उस क्षण पर जब इस कण के लिये y का मान 32 m हो x का मान D meters है। D का मान होगा :

Options :

1. 50

2. 32

3. 60

4. 40

Question Number : 2 Question Type : MCQ Option Shuffling : Yes
Correct Marks : 4 Wrong Marks : 1

$t=0$ સમયે, $3.0 \hat{i}$ m/s ના પ્રારંભિક વેગ અને અચળ

પ્રવેગ $(6.0 \hat{i} + 4.0 \hat{j})$ m/s² સાથે એક કણ

ઉગમબિંદુ આગળથી શરૂ કરી x - y સમતલમાં ગતિ કરે છે. જ્યારે કણનો y -યામ 32 m થાય તે સમયે કણનો x -યામ D m છે. D નું મૂલ્ય _____ (સૌથી નજીકના પૂર્ણાંક) છે.

Options :

1. 50

2. 32

3. 60

4. 40

Question Number : 3 Question Type : MCQ Option Shuffling : Yes
Correct Marks : 4 Wrong Marks : 1

A uniformly thick wheel with moment of inertia I and radius R is free to rotate about its centre of mass (see fig). A massless string is wrapped over its rim and two blocks of masses m_1 and m_2 ($m_1 > m_2$) are attached to the ends of the string. The system is released from rest. The angular speed of the wheel when m_1 descends by a distance h is :

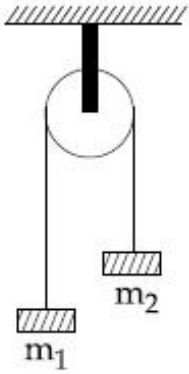

Options :

1. $\left[\frac{2(m_1 + m_2) gh}{(m_1 + m_2) R^2 + I} \right]^{\frac{1}{2}}$

2. $\left[\frac{2(m_1 - m_2) gh}{(m_1 + m_2) R^2 + I} \right]^{\frac{1}{2}}$

3. $\left[\frac{(m_1 - m_2)}{(m_1 + m_2) R^2 + I} \right]^{\frac{1}{2}} gh$

4. $\left[\frac{m_1 + m_2}{(m_1 + m_2) R^2 + I} \right]^{\frac{1}{2}} gh$

Question Number : 3 Question Type : MCQ Option Shuffling : Yes

Correct Marks : 4 Wrong Marks : 1

त्रिज्या R और जड़त्व आघूर्ण I का एक एकसमान मोटाई का पहिया अपने द्रव्यमान केन्द्र के चारों ओर घूर्णन के लिये स्वतन्त्र है (चित्र देखें)। एक द्रव्यमानरहित डोरी इस पहिये के चारों ओर लपेटी गयी है और डोरी के दो छोरों पर द्रव्यमान m_1 तथा m_2 ($m_1 > m_2$) के दो गुटके लटकाये गये हैं। इस निकाय को विरामावस्था से छोड़ा जाता है। ऐसे में जब द्रव्यमान m_1 का गुटका नीचे की ओर चलते हुए h दूरी तय कर लें तो पहिये का कोणीय वेग होगा :

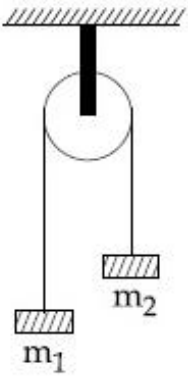

Options :

1. $\left[\frac{2(m_1 + m_2) gh}{(m_1 + m_2) R^2 + I} \right]^{\frac{1}{2}}$

2. $\left[\frac{2(m_1 - m_2) gh}{(m_1 + m_2) R^2 + I} \right]^{\frac{1}{2}}$

3. $\left[\frac{(m_1 - m_2)}{(m_1 + m_2) R^2 + I} \right]^{\frac{1}{2}} gh$

4. $\left[\frac{m_1 + m_2}{(m_1 + m_2) R^2 + I} \right]^{\frac{1}{2}} gh$

I જેટલી જડત્વની ચાકમાત્રા અને R જેટલી ત્રિજ્યા ધરાવતું પૈડું તેના દ્રવ્યમાન કેન્દ્રને ફરતે અક્ષને અનુલક્ષીને પરિભ્રમણ કરવા માટે મુક્ત છે (આકૃતિ જુઓ). તેની ધરી પર એક દળરહિત સ્પ્રિંગ વીંટાળવામાં આવે છે અને સ્પ્રિંગના છેડા ઉપર m_1 અને m_2 ($m_1 > m_2$) દળ ધરાવતા બે ચોસલા જોડવામાં આવે છે. જ્યારે m_1 દળ નીચે તરફ h જેટલું ગતિ કરે (પડે) ત્યારે પૈડાની કોણીય ઝડપ _____ છે.

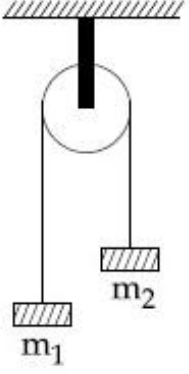

Options :

1. $\left[\frac{2(m_1 + m_2) gh}{(m_1 + m_2) R^2 + I} \right]^{\frac{1}{2}}$

2. $\left[\frac{2(m_1 - m_2) gh}{(m_1 + m_2) R^2 + I} \right]^{\frac{1}{2}}$

3. $\left[\frac{(m_1 - m_2)}{(m_1 + m_2) R^2 + I} \right]^{\frac{1}{2}} gh$

4. $\left[\frac{m_1 + m_2}{(m_1 + m_2) R^2 + I} \right]^{\frac{1}{2}} gh$

A particle of mass m is projected with a

speed u from the ground at an angle $\theta = \frac{\pi}{3}$

w.r.t. horizontal (x -axis). When it has reached its maximum height, it collides completely inelastically with another

particle of the same mass and velocity $u \hat{i}$.

The horizontal distance covered by the combined mass before reaching the ground is :

Options :

1. $\frac{3\sqrt{3}}{8} \frac{u^2}{g}$

2. $\frac{5}{8} \frac{u^2}{g}$

3. $2\sqrt{2} \frac{u^2}{g}$

4. $\frac{3\sqrt{2}}{4} \frac{u^2}{g}$

Question Number : 4 Question Type : MCQ Option Shuffling : Yes

Correct Marks : 4 Wrong Marks : 1

द्रव्यमान m के एक कण को u गति से क्षैतिज दिशा

(इसे x -अक्ष लें) से $\theta = \frac{\pi}{3}$ कोण बनाते हुए प्रक्षेपित

किया जाता है। अपनी अधिकतम ऊँचाई पर पहुँचने पर यह कण समान द्रव्यमान के एक दूसरे कण, जिसका

वेग $u \hat{i}$ है, से पूर्णतः अप्रत्यास्थ रूप से टकराता है।

संयुक्त कणों द्वारा धरती पर पहुँचने से पहले क्षैतिज दिशा में चली गयी दूरी होगी :

Options :

1. $\frac{3\sqrt{3}}{8} \frac{u^2}{g}$

2. $\frac{5}{8} \frac{u^2}{g}$

3. $2\sqrt{2} \frac{u^2}{g}$

4. $\frac{3\sqrt{2}}{4} \frac{u^2}{g}$

Question Number : 4 Question Type : MCQ Option Shuffling : Yes

Correct Marks : 4 Wrong Marks : 1

m દળ ધરાવતા એક કણને સમક્ષિતિજ અક્ષ (x- અક્ષ)ની

દિશાને સાપેક્ષ જમીનથી $\theta = \frac{\pi}{3}$ ના કોણે u જેટલી

ઝડપથી પ્રક્ષિપ્ત કરવામાં આવે છે. તે જ્યારે તેની મહત્તમ

ઉંચાઈ એ પહોંચે છે ત્યારે તે સમાન દળ ધરાવતા અને

u જેટલો વેગ ધરાવતા બીજા કણ સાથે સંપૂર્ણ

અસ્થિતિસ્થાપક અથડામણ અનુભવે છે. આ સંયુક્ત

દળો જમીન ઉપર પડે તે પહેલા કાપેલું સમક્ષિતિજ અંતર

_____ છે.

Options :

1. $\frac{3\sqrt{3}}{8} \frac{u^2}{g}$

2. $\frac{5}{8} \frac{u^2}{g}$

3. $2\sqrt{2} \frac{u^2}{g}$

4. $\frac{3\sqrt{2}}{4} \frac{u^2}{g}$

Question Number : 5 Question Type : MCQ Option Shuffling : Yes
Correct Marks : 4 Wrong Marks : 1

A rod of length L has non-uniform linear

mass density given by $\rho(x) = a + b \left(\frac{x}{L}\right)^2$,

where a and b are constants and $0 \leq x \leq L$.

The value of x for the centre of mass of the rod is at:

Options :

1. $\frac{3}{4} \left(\frac{2a + b}{3a + b}\right) L$

2. $\frac{3}{2} \left(\frac{2a + b}{3a + b}\right) L$

3. $\frac{4}{3} \left(\frac{a + b}{2a + 3b}\right) L$

4. $\frac{3}{2} \left(\frac{a + b}{2a + b}\right) L$

Question Number : 5 Question Type : MCQ Option Shuffling : Yes
Correct Marks : 4 Wrong Marks : 1

लम्बाई L की एक छड़ का रेखीय द्रव्यमान घनत्व $\rho(x)$

असमान है और इसका मान $\rho(x) = a + b \left(\frac{x}{L}\right)^2$

है। यहाँ पर a और b स्थिरांक है और $0 \leq x \leq L$.
छड़ के द्रव्यमान केन्द्र के लिये x का मान होगा :

Options :

1. $\frac{3}{4} \left(\frac{2a + b}{3a + b}\right) L$

2. $\frac{3}{2} \left(\frac{2a + b}{3a + b}\right) L$

3. $\frac{4}{3} \left(\frac{a + b}{2a + 3b}\right) L$

4. $\frac{3}{2} \left(\frac{a + b}{2a + b}\right) L$

Question Number : 5 Question Type : MCQ Option Shuffling : Yes

Correct Marks : 4 Wrong Marks : 1

L લંબાઈના એક સળિયામાં અનિયમિત રેખીય દળ ઘનતા

$\rho(x) = a + b \left(\frac{x}{L}\right)^2$ વડે અપાય છે, જ્યાં a અને b

અચળાંકો છે અને $0 \leq x \leq L$ છે. સળિયાનાં દ્રવ્યમાન
કેન્દ્ર માટે x નું મૂલ્ય _____ છે.

Options :

1. $\frac{3}{4} \left(\frac{2a + b}{3a + b}\right) L$

2. $\frac{3}{2} \left(\frac{2a + b}{3a + b}\right) L$

3. $\frac{4}{3} \left(\frac{a+b}{2a+3b} \right) L$

4. $\frac{3}{2} \left(\frac{a+b}{2a+b} \right) L$

Question Number : 6 Question Type : MCQ Option Shuffling : Yes
Correct Marks : 4 Wrong Marks : 1

A spring mass system (mass m , spring constant k and natural length l) rests in equilibrium on a horizontal disc. The free end of the spring is fixed at the centre of the disc. If the disc together with spring mass system, rotates about its axis with an angular velocity ω , ($k \gg m\omega^2$) the relative change in the length of the spring is best given by the option :

Options :

1. $\frac{m\omega^2}{k}$

2. $\frac{2m\omega^2}{k}$

3. $\frac{m\omega^2}{3k}$

4. $\sqrt{\frac{2}{3}} \left(\frac{m\omega^2}{k} \right)$

Question Number : 6 Question Type : MCQ Option Shuffling : Yes
Correct Marks : 4 Wrong Marks : 1

एक कमानी द्रव्यमान (spring mass) निकाय (द्रव्यमान m , कमानी स्थिरांक k और प्राकृतिक लम्बाई l) संतुलित अवस्था में एक क्षैतिज डिस्क पर रखा हुआ है। कमानी का खाली सिरा डिस्क के केन्द्र पर आबद्ध है। यदि अब डिस्क को इस कमानी द्रव्यमान निकाय के साथ इसके अक्ष के चारों ओर ω ($k \gg m\omega^2$) कोणीय वेग से घुमाया जाय तो l के सापेक्ष कमानी की लम्बाई में बदलाव के लिये कौन सा विकल्प सर्वश्रेष्ठ है?

Options :

1. $\frac{m\omega^2}{k}$

2. $\frac{2m\omega^2}{k}$

3. $\frac{m\omega^2}{3k}$

4. $\sqrt{\frac{2}{3}} \left(\frac{m\omega^2}{k} \right)$

Question Number : 6 Question Type : MCQ Option Shuffling : Yes
Correct Marks : 4 Wrong Marks : 1

એક સ્પ્રિંગ-દળ તંત્ર (દળ m , સ્પ્રિંગ અચળાંક k અને પ્રાકૃતિક લંબાઈ l) એક સમક્ષિતિજ તકિત પર સંતુલનસ્થિતિમાં સ્થિર છે. સ્પ્રિંગનો મુક્ત છેડો તકિતના કેન્દ્ર આગળ જડિત કરેલ છે. જો તકિત આ સ્પ્રિંગ-દળ તંત્ર સાથે ω ($k \gg m\omega^2$) જેટલા કોણીય વેગથી તેની અક્ષને સાપેક્ષે પરિભ્રમણ કરે તો સ્પ્રિંગની લંબાઈમાં થતો સાપેક્ષ ફેરફાર _____ છે.

Options :

1. $\frac{m\omega^2}{k}$

2. $\frac{2m\omega^2}{k}$

3. $\frac{m\omega^2}{3k}$

4. $\sqrt{\frac{2}{3}} \left(\frac{m\omega^2}{k} \right)$

Question Number : 7 Question Type : MCQ Option Shuffling : Yes

Correct Marks : 4 Wrong Marks : 1

Planet A has mass M and radius R .

Planet B has half the mass and half the radius of Planet A. If the escape velocities from the Planets A and B are v_A and v_B ,

respectively, then $\frac{v_A}{v_B} = \frac{n}{4}$. The value of

n is :

Options :

1. 1

2. 2

3. 3

4. 4

Question Number : 7 Question Type : MCQ Option Shuffling : Yes

Correct Marks : 4 Wrong Marks : 1

एक ग्रह A का द्रव्यमान M तथा त्रिज्या R है एक दूसरे ग्रह B का द्रव्यमान और त्रिज्या दोनों ही ग्रह A से आधी हैं। यदि ग्रह A और B से पलायन गतियाँ क्रमशः

$$v_A \text{ व } v_B \text{ हो तो } \frac{v_A}{v_B} = \frac{n}{4} \text{ । } n \text{ का मान है :}$$

Options :

1. 1

2. 2

3. 3

4. 4

Question Number : 7 Question Type : MCQ Option Shuffling : Yes

Correct Marks : 4 Wrong Marks : 1

એક ગ્રહ A ને દળ M અને ત્રિજ્યા R છે. ગ્રહ B ને, ગ્રહ A કરતાં આડધું દળ અને અડધી ત્રિજ્યા છે. જો ગ્રહ A અને B માટે નિષ્ક્રમણ વેગ અનુક્રમે v_A અને v_B હોય

$$\text{તો } \frac{v_A}{v_B} = \frac{n}{4} ; n \text{ નું મૂલ્ય } \underline{\hspace{2cm}} \text{ હશે.}$$

Options :

1. 1

2. 2

3. 3

4. 4

Question Number : 8 Question Type : MCQ Option Shuffling : Yes
Correct Marks : 4 Wrong Marks : 1

Two steel wires having same length are suspended from a ceiling under the same load. If the ratio of their energy stored per unit volume is 1 : 4, the ratio of their diameters is :

Options :

1. $1 : \sqrt{2}$

2. 1 : 2

3. $\sqrt{2} : 1$

4. 2 : 1

Question Number : 8 Question Type : MCQ Option Shuffling : Yes
Correct Marks : 4 Wrong Marks : 1

समान लम्बाई के दो स्टील के तारों पर समान भार बाँधकर इन्हें छत से लटकाया गया है। यदि इन तारों के प्रति इकाई आयतन में संचित ऊर्जा का अनुपात 1 : 4 है तो तारों के व्यास का अनुपात होगा :

Options :

1. $1 : \sqrt{2}$

2. 1:2

3. $\sqrt{2}:1$

4. 2:1

Question Number : 8 Question Type : MCQ Option Shuffling : Yes

Correct Marks : 4 Wrong Marks : 1

સમાન લંબાઈ ધરાવતા બે સ્ટીલના તારોને છતથી સમાન ભાર લગાવી લટકાવવામાં આવેલ છે. જો તેમનાંમાં પ્રતિ કદ સંગ્રાહતી ઉર્જાનો ગુણોત્તર 1 : 4 હોય તો તેમના વ્યાસનો ગુણોત્તર _____ છે.

Options :

1. $1:\sqrt{2}$

2. 1:2

3. $\sqrt{2}:1$

4. 2:1

Question Number : 9 Question Type : MCQ Option Shuffling : Yes

Correct Marks : 4 Wrong Marks : 1

A small spherical droplet of density d is floating exactly half immersed in a liquid of density ρ and surface tension T . The radius of the droplet is (take note that the surface tension applies an upward force on the droplet) :

Options :

1. $r = \sqrt{\frac{T}{(d - \rho)g}}$

2. $r = \sqrt{\frac{3T}{(2d - \rho)g}}$

3. $r = \sqrt{\frac{2T}{3(d + \rho)g}}$

4. $r = \sqrt{\frac{T}{(d + \rho)g}}$

Question Number : 9 Question Type : MCQ Option Shuffling : Yes

Correct Marks : 4 Wrong Marks : 1

घनत्व d की एक छोटी गोलाकार बूंद घनत्व ρ तथा पृष्ठ तनाव T के द्रव में ठीक आधा डूबा हुआ तैरता है। इस बूंद की त्रिज्या का मान है (ध्यान दें कि पृष्ठतनाव बूंद पर ऊपर की ओर बल लगाता है) :

Options :

1. $r = \sqrt{\frac{T}{(d - \rho)g}}$

2. $r = \sqrt{\frac{3T}{(2d - \rho)g}}$

3. $r = \sqrt{\frac{2T}{3(d + \rho)g}}$

4. $r = \sqrt{\frac{T}{(d + \rho)g}}$

Question Number : 9 Question Type : MCQ Option Shuffling : Yes
Correct Marks : 4 Wrong Marks : 1

d ઘનતા ધરાવતું એક નાનું ગોળાકાર બુંદ, ρ જેટલી ઘનતા અને T જેટલું પૃષ્ઠતાણ ધરાવતા પ્રવાહીમાં બરાબર અડધું ડૂબેલું રહે તેમ તરે છે. બુંદની ત્રિજ્યા _____ છે. (નોંધો કે પૃષ્ઠતાણ, બિંદુ પર ઉર્ધ્વાદિશમાં બળ લગાવે છે)

Options :

1. $r = \sqrt{\frac{T}{(d - \rho)g}}$

2. $r = \sqrt{\frac{3T}{(2d - \rho)g}}$

3. $r = \sqrt{\frac{2T}{3(d + \rho)g}}$

4. $r = \sqrt{\frac{T}{(d + \rho)g}}$

Question Number : 10 Question Type : MCQ Option Shuffling : Yes
Correct Marks : 4 Wrong Marks : 1

Two gases - argon (atomic radius 0.07 nm, atomic weight 40) and xenon (atomic radius 0.1 nm, atomic weight 140) have the same number density and are at the same temperature. The ratio of their respective mean free times is closest to :

Options :

1. 3.67

2. 4.67

3. 2.3

4. 1.83

Question Number : 10 Question Type : MCQ Option Shuffling : Yes
Correct Marks : 4 Wrong Marks : 1

दो गैसों - आर्गन (परमाणु की त्रिज्या = 0.07 nm और परमाणु भार = 40), तथा ज़ीनॉन (परमाणु की त्रिज्या = 0.1 nm, परमाणु भार = 140) के इकाई आयतन में परमाणुओं की संख्या एकसमान है तथा उनका तापमान भी एकसमान है। इन गैसों (आर्गन और ज़ीनॉन) के परमाणुओं के औसत मुक्त काल (mean free time) का अनुपात निम्न में से किसके निकटतम है?

Options :

1. 3.67

2. 4.67

3. 2.3

4. 1.83

Question Number : 10 Question Type : MCQ Option Shuffling : Yes
Correct Marks : 4 Wrong Marks : 1

બે સમાન સંખ્યાઘનતા ધરાવતા વાયુઓ-આર્ગોન (પરમાણ્વીય ત્રિજ્યા = 0.07 nm, પરમાણુભાર = 40) અને ઝેનોન (પરમાણ્વીય ત્રિજ્યા = 0.1 nm, પરમાણુભાર = 140) ને સરખા તાપમાને રાખવામાં આવેલ છે. તેમના અનુક્રમે સરેરાશ મુક્ત સમયોનો ગુણોત્તર _____ ની નજીક થશે.

Options :

1. 3.67
2. 4.67
3. 2.3
4. 1.83

Question Number : 11 Question Type : MCQ Option Shuffling : Yes

Correct Marks : 4 Wrong Marks : 1

A wire of length L and mass per unit length $6.0 \times 10^{-3} \text{ kgm}^{-1}$ is put under tension of 540 N. Two consecutive frequencies that it resonates at are : 420 Hz and 490 Hz. Then L in meters is :

Options :

1. 5.1 m
2. 1.1 m
3. 2.1 m
4. 8.1 m

Question Number : 11 Question Type : MCQ Option Shuffling : Yes
Correct Marks : 4 Wrong Marks : 1

लम्बाई L के एक तार का प्रति इकाई लम्बाई द्रव्यमान $6.0 \times 10^{-3} \text{ kgm}^{-1}$ है तथा इस पर 540 N का तनाव लगाया हुआ है। यदि इसकी दो क्रमागत अनुनाद आवृत्तियों का मान 420 Hz और 490 Hz हो, तो L का मीटर में मान है :

Options :

1. 5.1 m
2. 1.1 m
3. 2.1 m
4. 8.1 m

Question Number : 11 Question Type : MCQ Option Shuffling : Yes
Correct Marks : 4 Wrong Marks : 1

L લંબાઈના અને એકમ લંબાઈ $6.0 \times 10^{-3} \text{ kgm}^{-1}$ દળ ધરાવતા તારને 540 N તણાવ હેઠળ રાખવામાં આવે છે. તે જે બે ક્રમિક આવૃત્તિઓથી કંપન કરે તે 420 Hz અને 490 Hz છે. તો L મીટરમાં _____ છે.

Options :

1. 5.1 m
2. 1.1 m
3. 2.1 m

Question Number : 12 Question Type : MCQ Option Shuffling : Yes

Correct Marks : 4 Wrong Marks : 1

Two identical capacitors A and B, charged to the same potential 5V are connected in two different circuits as shown below at time $t=0$. If the charge on capacitors A and B at time $t=CR$ is Q_A and Q_B respectively, then (Here e is the base of natural logarithm)

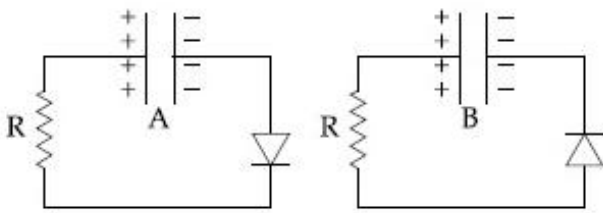

Options :

1. $Q_A = VC, Q_B = CV$

2. $Q_A = \frac{CV}{2}, Q_B = \frac{VC}{e}$

3. $Q_A = \frac{VC}{e}, Q_B = \frac{CV}{2}$

4. $Q_A = VC, Q_B = \frac{VC}{e}$

Question Number : 12 Question Type : MCQ Option Shuffling : Yes

Correct Marks : 4 Wrong Marks : 1

एकसमान विभव 5 V पर आवेशित दो समरूपी संधारित्रों A और B को समय $t=0$ पर नीचे दिखाये गये दो विभिन्न परिपथों के अनुसार जोड़ा जाता है। समय $t=CR$ पर संधारित्रों A और B पर आवेश क्रमशः Q_A और Q_B हो तो (यहाँ e प्राकृतिक लॉगैरिथम का आधार है)

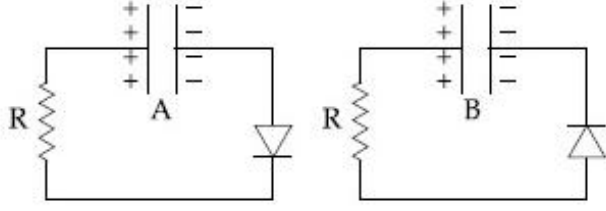

Options :

1. $Q_A = VC, Q_B = CV$

2. $Q_A = \frac{CV}{2}, Q_B = \frac{VC}{e}$

3. $Q_A = \frac{VC}{e}, Q_B = \frac{CV}{2}$

4. $Q_A = VC, Q_B = \frac{VC}{e}$

Question Number : 12 Question Type : MCQ Option Shuffling : Yes

Correct Marks : 4 Wrong Marks : 1

नीचे मुझ, $t=0$ समये समान स्थितिमां 5 V थी वीजभारीत करेल ने समान संधारको A अने B ने नीचे दशविल ने भिन्न परिपथोमां जोडवामां आवेल छे. ने संधारक उपर $t=CR$ समये केटलो विद्युतभार लशे? (अत्रे e अे प्राकृतिक logarithm नो आधार छे)

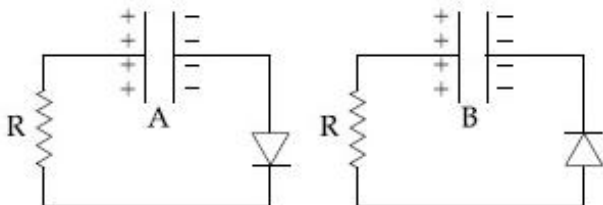

Options :

1. $Q_A = VC, Q_B = CV$

2. $Q_A = \frac{CV}{2}, Q_B = \frac{VC}{e}$

3. $Q_A = \frac{VC}{e}, Q_B = \frac{CV}{2}$

4. $Q_A = VC, Q_B = \frac{VC}{e}$

Question Number : 13 Question Type : MCQ Option Shuffling : Yes

Correct Marks : 4 Wrong Marks : 1

A small circular loop of conducting wire has radius a and carries current I . It is placed in a uniform magnetic field B perpendicular to its plane such that when rotated slightly about its diameter and released, it starts performing simple harmonic motion of time period T . If the mass of the loop is m then :

Options :

1. $T = \sqrt{\frac{2m}{IB}}$

2. $T = \sqrt{\frac{\pi m}{IB}}$

3. $T = \sqrt{\frac{2\pi m}{IB}}$

4. $T = \sqrt{\frac{\pi m}{2IB}}$

Question Number : 13 Question Type : MCQ Option Shuffling : Yes

Correct Marks : 4 Wrong Marks : 1

सुचालक तार से त्रिज्या a का एक छोटे वृत्ताकार छल्ले में विद्युत धारा I बह रही है। इसे एक एकसमान चुम्बकीय क्षेत्र B (जो कि इसके समतल के लम्बवत है) में इस प्रकार रखा जाता है कि जब इसे इसके व्यास के सापेक्ष थोड़ासा घुमाकर छोड़ा जाय तो यह आवर्तकाल T की सरल आवर्त गति करने लगता है। यदि छल्ले का द्रव्यमान m हो तो :

Options :

1. $T = \sqrt{\frac{2m}{IB}}$

2. $T = \sqrt{\frac{\pi m}{IB}}$

3. $T = \sqrt{\frac{2\pi m}{IB}}$

4. $T = \sqrt{\frac{\pi m}{2IB}}$

Question Number : 13 Question Type : MCQ Option Shuffling : Yes

Correct Marks : 4 Wrong Marks : 1

a ત્રિજ્યા ધરાવતા અને સુવાલક તારના બનેલા એક નાના વર્તુળાકાર ગૂંચળામાંથી I જેટલો વિદ્યુતપ્રવાહ વહે છે. તેને તેના સમતલને લંબ એવા ચુંબકીય ક્ષેત્ર B માં એવી રીતે મૂકવામાં આવે છે કે જેથી એને તેના વ્યાસને ફરતે સહેજ ભ્રમણ કરાવીને મુક્ત કરવામાં આવે ત્યારે તે T જેટલો આવર્ત ધરાવતી સરળ આવર્ત ગતિ કરવાનું શરૂ કરે છે. જો ગૂંચળાનું દળ m હોય તો _____ છે.

Options :

1. $T = \sqrt{\frac{2m}{IB}}$

2. $T = \sqrt{\frac{\pi m}{IB}}$

3. $T = \sqrt{\frac{2\pi m}{IB}}$

4. $T = \sqrt{\frac{\pi m}{2IB}}$

Question Number : 14 Question Type : MCQ Option Shuffling : Yes

Correct Marks : 4 Wrong Marks : 1

An electron gun is placed inside a long solenoid of radius R on its axis. The solenoid has n turns/length and carries a current I . The electron gun shoots an electron along the radius of the solenoid with speed v . If the electron does not hit the surface of the solenoid, maximum possible value of v is (all symbols have their standard meaning) :

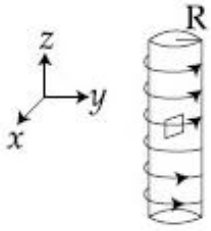

Options :

1. $\frac{e\mu_0 nIR}{m}$

2. $\frac{e\mu_0 nIR}{2m}$

3. $\frac{e\mu_0 nIR}{4m}$

4. $\frac{2e\mu_0 nIR}{m}$

Question Number : 14 Question Type : MCQ Option Shuffling : Yes
 Correct Marks : 4 Wrong Marks : 1

एक इलैक्ट्रॉन प्रक्षेपी (electron gun) को R त्रिज्या की एक लम्बी परिनालिका के अक्ष पर रखा हुआ है। परिनालिका में तार के n घुमाव प्रति इकाई लम्बाई है तथा इसमें बहने वाली विद्युत धारा का मान I है। इलैक्ट्रॉन प्रक्षेपी परिनालिका की त्रिज्या की दिशा में v गति से इलैक्ट्रॉन प्रक्षेपित करती है। यदि प्रक्षेपित इलैक्ट्रॉन परिनालिका की सतह से नहीं टकराते हैं तो v का अधिकतम मान कितना हो सकता है? (सभी अक्षरों का मानक अर्थ लें)

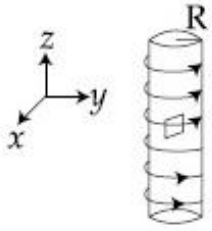

Options :

1. $\frac{e\mu_0 nIR}{m}$

2. $\frac{e\mu_0 nIR}{2m}$

3. $\frac{e\mu_0 nIR}{4m}$

4. $\frac{2e\mu_0 nIR}{m}$

Question Number : 14 Question Type : MCQ Option Shuffling : Yes

Correct Marks : 4 Wrong Marks : 1

એક ઇલેક્ટ્રોન ગન (બંદુક) ને ખૂબજ લાંબા અને R ત્રિજ્યા ધરાવતા સોલેનાઇડની અક્ષ પર રાખવામાં આવે છે. સોલેનાઇડમાં n આંટા/લંબાઈ છે અને તેમાંથી I જેટલો વિદ્યુતપ્રવાહ વહે છે. ઇલેક્ટ્રોન ગન હવે સોલેનાઇડની ત્રિજ્યા R ની દિશામાં v જેટલી ઝડપ સાથેનો ઇલેક્ટ્રોન છોડે છે. જો ઇલેક્ટ્રોન સોલેનાઇડની સપાટીને અથડાતો ના હોય તો v નું અધિકતમ સંભવિત મૂલ્ય _____ છે. (બધી જ સંજ્ઞાઓ પ્રમાણિત/રૈવાજીક અર્થ ધરાવે છે.)

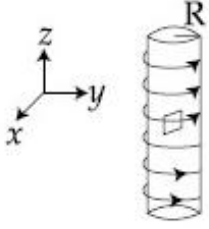

Options :

1. $\frac{e\mu_0 nIR}{m}$

2. $\frac{e\mu_0 nIR}{2m}$

3. $\frac{e\mu_0 nIR}{4m}$

4. $\frac{2e\mu_0 nIR}{m}$

Question Number : 15 Question Type : MCQ Option Shuffling : Yes

Correct Marks : 4 Wrong Marks : 1

In LC circuit the inductance $L = 40 \text{ mH}$ and capacitance $C = 100 \text{ } \mu\text{F}$. If a voltage $V(t) = 10\sin(314 t)$ is applied to the circuit, the current in the circuit is given as :

Options :

1. $0.52 \sin 314 t$

2. $0.52 \cos 314 t$

3. $10 \cos 314 t$

4. $5.2 \cos 314 t$

Question Number : 15 Question Type : MCQ Option Shuffling : Yes
Correct Marks : 4 Wrong Marks : 1

एक LC परिपथ में प्रेरकत्व $L=40 \text{ mH}$ तथा विद्युत धारिता $C=100 \mu\text{F}$ है। यदि वोल्टेज $V(t) = 10 \sin(314 t)$ इस परिपथ में लगायी जाय तो इसमें बहने वाली धारा होगी :

Options :

1. $0.52 \sin 314 t$

2. $0.52 \cos 314 t$

3. $10 \cos 314 t$

4. $5.2 \cos 314 t$

Question Number : 15 Question Type : MCQ Option Shuffling : Yes
Correct Marks : 4 Wrong Marks : 1

એક LC પરિપથમાં ઈન્ડક્ટર $L=40 \text{ mH}$ અને કેપેસિટર $C=100 \mu\text{F}$ છે. જો પરિપથને $V(t) = 10 \sin(314 t)$ જેટલો વોલ્ટેજ લગાવવામાં આવે તો પરિપથમાં વહેતો પ્રવાહ _____ છે.

Options :

1. $0.52 \sin 314 t$

2. $0.52 \cos 314 t$

3. $10 \cos 314 t$

4. $5.2 \cos 314 t$

Question Number : 16 Question Type : MCQ Option Shuffling : Yes

Correct Marks : 4 Wrong Marks : 1

A plane electromagnetic wave is

propagating along the direction $\frac{\hat{i} + \hat{j}}{\sqrt{2}}$,

with its polarization along the direction \hat{k} .

The correct form of the magnetic field of the wave would be (here B_0 is an appropriate constant) :

Options :

1. $B_0 \frac{\hat{i} + \hat{j}}{\sqrt{2}} \cos \left(\omega t - k \frac{\hat{i} + \hat{j}}{\sqrt{2}} \right)$

2. $B_0 \frac{\hat{j} - \hat{i}}{\sqrt{2}} \cos \left(\omega t + k \frac{\hat{i} + \hat{j}}{\sqrt{2}} \right)$

3. $B_0 \frac{\hat{i} - \hat{j}}{\sqrt{2}} \cos \left(\omega t - k \frac{\hat{i} + \hat{j}}{\sqrt{2}} \right)$

4. $B_0 \hat{k} \cos\left(\omega t - k \frac{\hat{i} + \hat{j}}{\sqrt{2}}\right)$

Question Number : 16 Question Type : MCQ Option Shuffling : Yes
Correct Marks : 4 Wrong Marks : 1

एक समतल विद्युत-चुम्बकीय तरंग $\frac{\hat{i} + \hat{j}}{\sqrt{2}}$ दिशा में

चल रही है तथा इसका ध्रुवण (polarization) \hat{k} दिशा में है। इस तरंग का चुम्बकीय क्षेत्र होगा (यहाँ पर B_0 एक उपयुक्त स्थिरांक है) :

Options :

1. $B_0 \frac{\hat{i} + \hat{j}}{\sqrt{2}} \cos\left(\omega t - k \frac{\hat{i} + \hat{j}}{\sqrt{2}}\right)$

2. $B_0 \frac{\hat{j} - \hat{i}}{\sqrt{2}} \cos\left(\omega t + k \frac{\hat{i} + \hat{j}}{\sqrt{2}}\right)$

3. $B_0 \frac{\hat{i} - \hat{j}}{\sqrt{2}} \cos\left(\omega t - k \frac{\hat{i} + \hat{j}}{\sqrt{2}}\right)$

4. $B_0 \hat{k} \cos\left(\omega t - k \frac{\hat{i} + \hat{j}}{\sqrt{2}}\right)$

Question Number : 16 Question Type : MCQ Option Shuffling : Yes
Correct Marks : 4 Wrong Marks : 1

એક સમતલ ચુંબકીય તરંગ $\frac{\hat{i} + \hat{j}}{\sqrt{2}}$ દિશામાં પ્રસરણ થઈ

રહ્યું છે કે જે \hat{k} દિશામાં ધ્રુવીભૂત છે. તો તરંગ માટે સાચું ચુંબકીય ક્ષેત્રનું સ્વરૂપ _____ છે. (અહીં B_0 એક યોગ્ય અચળાંક છે)

Options :

1. $B_0 \frac{\hat{i} + \hat{j}}{\sqrt{2}} \cos\left(\omega t - k \frac{\hat{i} + \hat{j}}{\sqrt{2}}\right)$

2. $B_0 \frac{\hat{j} - \hat{i}}{\sqrt{2}} \cos\left(\omega t + k \frac{\hat{i} + \hat{j}}{\sqrt{2}}\right)$

3. $B_0 \frac{\hat{i} - \hat{j}}{\sqrt{2}} \cos\left(\omega t - k \frac{\hat{i} + \hat{j}}{\sqrt{2}}\right)$

4. $B_0 \hat{k} \cos\left(\omega t - k \frac{\hat{i} + \hat{j}}{\sqrt{2}}\right)$

Question Number : 17 Question Type : MCQ Option Shuffling : Yes

Correct Marks : 4 Wrong Marks : 1

There is a small source of light at some depth below the surface of water (refractive

index = $\frac{4}{3}$) in a tank of large cross sectional

surface area. Neglecting any reflection from the bottom and absorption by water, percentage of light that emerges out of surface is (nearly) :

[Use the fact that surface area of a spherical cap of height h and radius of curvature r is $2\pi rh$]

Options :

1. 50%

2. 34%

3. 21%

4. 17%

Question Number : 17 Question Type : MCQ Option Shuffling : Yes

Correct Marks : 4 Wrong Marks : 1

एक हौज (tank), जिसकी सतह का आकार बहुत

बड़ा है, में पानी (अपवर्तनांक = $\frac{4}{3}$) भरा हुआ है

और पानी की सतह के नीचे प्रकाश का एक छोटा स्रोत रखा हुआ है। यदि परावर्तन और पानी में अवशोषण द्वारा प्रकाश की होने वाली क्षति को नगण्य माना जाये तो पानी की सतह से बाहर आने वाला प्रकाश का प्रतिशत लगभग है: (एक गोलीय सतह, जिसकी ऊँचाई h हो और इसी वक्रता त्रिज्या r हो तो इसका क्षेत्रफल $2\pi rh$ होता है)

Options :

1. 50%

2. 34%

3. 21%

4. 17%

Question Number : 17 Question Type : MCQ Option Shuffling : Yes

એક નાનું પ્રકાશ ઉદ્ગમ, ખૂબ મોટા આડછેદનું ક્ષેત્રફળ ધરાવતી સપાટીની બનેલી ટાંકીમાં રહેલ પાણી (વક્રીભવનાંક $= \frac{4}{3}$) ની સપાટીથી અમુક ઉંચાઈએ રહેલ છે. તળિયાથી થતું પ્રકાશનું પરાવર્તન અને પાણી દ્વારા થતું શોષણ અવગણતા સપાટીમાંથી નિર્ગમન પામતો પ્રતિશત પ્રકાશ (લગભગ) _____ છે. (r જેટલી વક્રતાત્રિજ્યા ધરાવતા અને h જેટલી ઉંચાઈ ધરાવતા ગોળાકાર ઘંકણ (cap)ની સપાટીનું ક્ષેત્રફળ $2\pi rh$ થાય તે હકીકત નો ઉપયોગ કરો)

Options :

1. 50%

2. 34%

3. 21%

4. 17%

Question Number : 18 Question Type : MCQ Option Shuffling : Yes

Correct Marks : 4 Wrong Marks : 1

An electron of mass m and magnitude of charge $|e|$ initially at rest gets accelerated by a constant electric field E . The rate of change of de-Broglie wavelength of this electron at time t ignoring relativistic effects is :

Options :

1. $\frac{-h}{|e|Et^2}$

2. $\frac{|e|Et}{h}$

3. $-\frac{h}{|e|E\sqrt{t}}$

4. $-\frac{h}{|e|Et}$

Question Number : 18 Question Type : MCQ Option Shuffling : Yes
Correct Marks : 4 Wrong Marks : 1

एक इलैक्ट्रॉन का द्रव्यमान m तथा इस पर आवेश का मान $|e|$ है। यह विरामावस्था में है तथा इस पर एक स्थिर विद्युत क्षेत्र E लगाकर इसे त्वरित किया जाता है। सापेक्षता के प्रभाव (relativistic effects) को नगण्य मानते हुए इलैक्ट्रॉन की डी-ब्रोग्ली तरंगदैर्घ्य की समय t पर बदलने की दर होगी :

Options :

1. $\frac{-h}{|e|Et^2}$

2. $\frac{|e|Et}{h}$

3. $-\frac{h}{|e|E\sqrt{t}}$

4. $-\frac{h}{|e|Et}$

Question Number : 18 Question Type : MCQ Option Shuffling : Yes
Correct Marks : 4 Wrong Marks : 1

પ્રારંભમાં સ્થિર હોય અને m દળ અને માન $|e|$ જેટલો વિદ્યુતભાર ધરાવતા ઇલેક્ટ્રોનને અચળ વિદ્યુતક્ષેત્ર E વડે પ્રવેગીત કરવામાં આવે છે. સાપેક્ષતાવાદ અસરને અવગણતાં આ ઇલેક્ટ્રોનની t સમયે ડી-બ્રોગ્લી તરંગલંબાઈમાં થતો ફેરફારનો દર _____ છે.

Options :

1. $\frac{-h}{|e|Et^2}$

2. $\frac{|e|Et}{h}$

3. $-\frac{h}{|e|E\sqrt{t}}$

4. $-\frac{h}{|e|Et}$

Question Number : 19 Question Type : MCQ Option Shuffling : Yes

Correct Marks : 4 Wrong Marks : 1

The energy required to ionise a hydrogen like ion in its ground state is 9 Rydbergs.

What is the wavelength of the radiation emitted when the electron in this ion jumps from the second excited state to the ground state ?

Options :

1. 11.4 nm

2. 24.2 nm

3. 8.6 nm

4. 35.8 nm

Question Number : 19 Question Type : MCQ Option Shuffling : Yes

Correct Marks : 4 Wrong Marks : 1

हाइड्रोजन परमाणु जैसे एक आयन जो कि उसकी निम्नतम अवस्था में है को आयनित करने के लिये 9 रिडबर्ग ऊर्जा की आवश्यकता पड़ती है। यदि इस आयन में इलेक्ट्रॉन दूसरी उत्तेजित अवस्था से पहली उत्तेजित अवस्था में आये तो उत्सर्जित विकिरण का तरंगदैर्घ्य होगा :

Options :

1. 11.4 nm

2. 24.2 nm

3. 8.6 nm

4. 35.8 nm

Question Number : 19 Question Type : MCQ Option Shuffling : Yes

Correct Marks : 4 Wrong Marks : 1

धरास्थितिमां रहेला हाइड्रोजन परमाणुनुं आयनीकरण करवाभाटे 9 रिडबर्ग ऊर्जा बरोधये छे. ज्यारे आयनमां इलेक्ट्रॉन द्वितीय उत्तेजित अवस्थामांथी धरास्थितिमां संक्रांति करे त्यारे उत्सर्जिता विकिरणानी तरंगलंबाई केटली हसे?

Options :

1. 11.4 nm

2. 24.2 nm

3. 8.6 nm

4. 35.8 nm

Question Number : 20 Question Type : MCQ Option Shuffling : Yes
 Correct Marks : 4 Wrong Marks : 1

The current i in the network is :

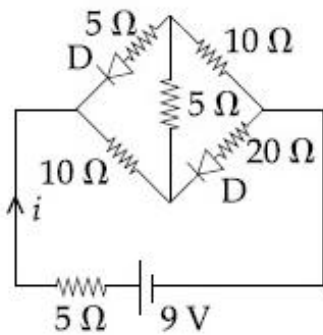

Options :

1. 0.6 A

2. 0.3 A

3. 0.2 A

4. 0 A

Question Number : 20 Question Type : MCQ Option Shuffling : Yes
 Correct Marks : 4 Wrong Marks : 1

दिये गये नेटवर्क में विद्युत धारा i का मान है :

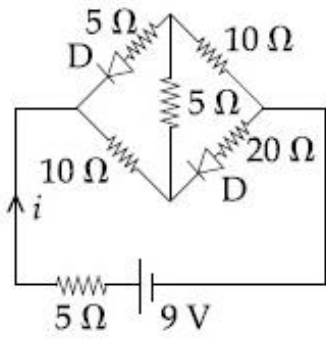

Options :

1. 0.6 A
2. 0.3 A
3. 0.2 A
4. 0 A

Question Number : 20 Question Type : MCQ Option Shuffling : Yes
Correct Marks : 4 Wrong Marks : 1

આપેલ પરિપથમાં વહેતો પ્રવાહ i _____ છે.

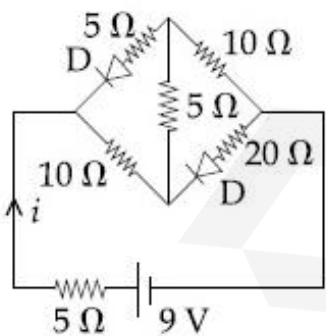

Options :

1. 0.6 A

2. 0.3 A

3. 0.2 A

4. 0 A

Sub-Section Number: 2
Sub-Section Id: 405036141
Question Shuffling Allowed : Yes

Question Number : 21 Question Type : SA

Correct Marks : 4 Wrong Marks : 0

Starting at temperature 300 K, one mole of an ideal diatomic gas ($\gamma = 1.4$) is first compressed adiabatically from volume

V_1 to $V_2 = \frac{V_1}{16}$. It is then allowed to

expand isobarically to volume $2V_2$. If all the processes are the quasi-static then the final temperature of the gas (in °K) is (to the nearest integer) _____.

Response Type: Numeric

Evaluation Required For SA: Yes

Show Word Count: Yes

Answers Type: Range

Possible Answers :

1816 to 1820

Question Number : 21 Question Type : SA

Correct Marks : 4 Wrong Marks : 0

तापमान 300 K से शुरू होकर 1 मोल द्विपरमाणुक आदर्श गैस ($\gamma = 1.4$) का पहले रुद्धोष्म प्रक्रिया द्वारा

V_1 आयतन से $V_2 = \frac{V_1}{16}$ आयतन तक संपीडन किया

जाता है। तत्पश्चात् इसे समदाबीय प्रक्रिया द्वारा $2V_2$ आयतन तक प्रसारित होने दिया जाता है। यदि सभी प्रक्रियाएँ स्थैतिककल्प (quasi-static) हों तो गैस का अन्तिम तापमान का (निकटतम पूर्णांक ($^{\circ}\text{K}$ में)) होगा _____ ।

Response Type: Numeric

Evaluation Required For SA: Yes

Show Word Count: Yes

Answers Type: Range

Possible Answers :

1816 to 1820

Question Number : 21 **Question Type :** SA

Correct Marks : 4 **Wrong Marks :** 0

300 K तापमाने शुरु करीने एक मोल आदर्श द्विपरमाणुक

वायु ($\gamma = 1.4$) ने प्रथम V_1 कदथी $V_2 = \frac{V_1}{16}$ सुधी

समोष्मी रीते दबाववामां आवे छे. तेनुं पछी समदाबीय रीते $2V_2$ जेटला कद सुधी विस्तरण करवा देवामां आवे छे. जे अधी ज प्रक्रियाओ आंशिक स्थिति (quasi-static) होय तो वायुनुं परिणामी तापमान ($^{\circ}\text{K}$ मां) _____ (सौथी नञ्जकनो पूर्णांक) छे.

Response Type: Numeric

Evaluation Required For SA: Yes

Show Word Count: Yes

Answers Type: Range

Possible Answers :

1816 to 1820

Question Number : 22 **Question Type :** SA

Correct Marks : 4 **Wrong Marks :** 0

चित्र में दिखाये गये बक्से से होकर विद्युत क्षेत्र

$\vec{E} = 4x\hat{i} - (y^2 + 1)\hat{j}$ N/C निकलता है। यदि

बक्से के ABCD तथा BCGF समतलों में से होकर जाने वाले फ्लक्स का मान क्रमशः ϕ_1 तथा ϕ_{II} है तब इनमें अन्तर $(\phi_1 - \phi_{II})$ (Nm^2/C) में होगा _____ ।

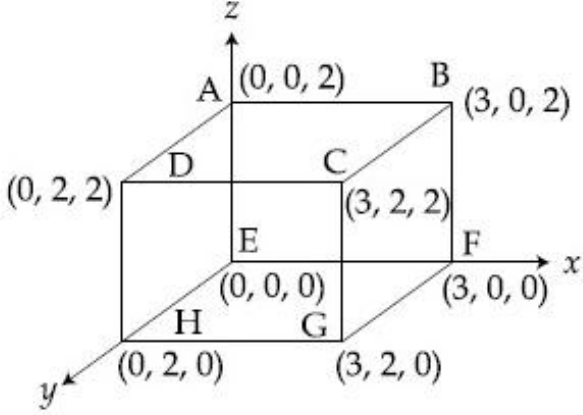

Response Type: Numeric

Evaluation Required For SA: Yes

Show Word Count: Yes

Answers Type: Range

Possible Answers :

-48 to -48

Question Number : 22 **Question Type :** SA

Correct Marks : 4 **Wrong Marks :** 0

विद्युतक्षेत्र $\vec{E} = 4x\hat{i} - (y^2 + 1)\hat{j}$ N/C मुख्य

आकृतिमां दर्शाव्या अनुसार ढोक्षमांथी पसार थाय छे.

सपाटीओ ABCD अने BCGF मांथी पसार थतां

विद्युतक्षेत्रना इलक्स अनुक्रमे ϕ_1 अने ϕ_{II} थी दर्शावेल

छे. तो $(\phi_1 - \phi_{II})$ तइवत (Nm^2/C मां)

_____ छे.

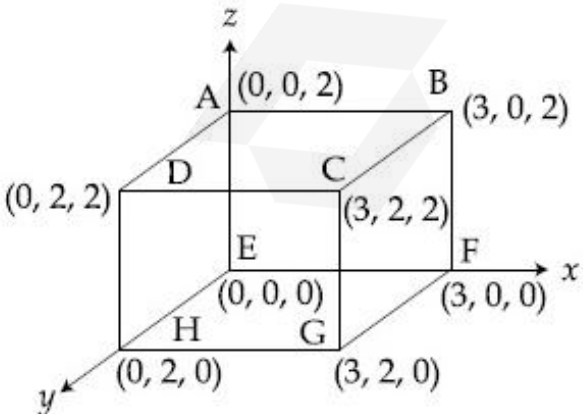

Response Type: Numeric

Evaluation Required For SA: Yes

Show Word Count: Yes

Answers Type: Range

Question Number : 22 Question Type : SA

Correct Marks : 4 Wrong Marks : 0

An electric field $\vec{E} = 4x\hat{i} - (y^2 + 1)\hat{j}$ N/C passes through the box shown in figure. The flux of the electric field through surfaces ABCD and BCGF are marked as ϕ_I and ϕ_{II} respectively. The difference between $(\phi_I - \phi_{II})$ is (in Nm^2/C) _____.

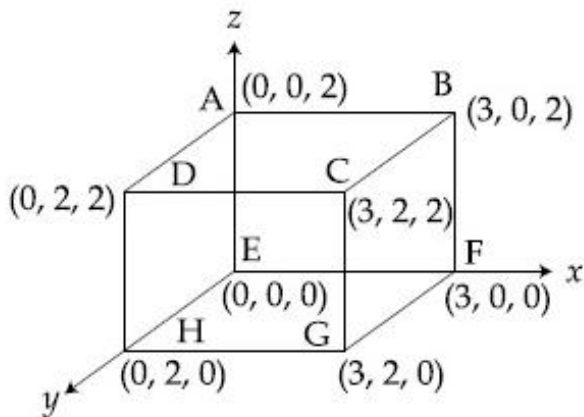

Response Type: Numeric

Evaluation Required For SA: Yes

Show Word Count: Yes

Answers Type: Range

Possible Answers :

-48 to -48

Question Number : 23 Question Type : SA

Correct Marks : 4 Wrong Marks : 0

In a meter bridge experiment S is a standard resistance. R is a resistance wire. It is found that balancing length is $l = 25$ cm. If R is replaced by a wire of half length and half diameter that of R of same material, then the balancing distance l' (in cm) will now be _____.

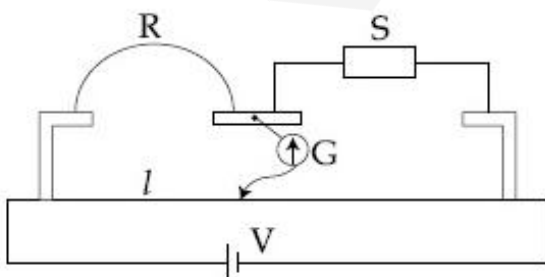

Response Type: Numeric

Evaluation Required For SA: Yes

Show Word Count: Yes

Answers Type: Range

Possible Answers :

40 to 40

Question Number : 23 Question Type : SA

Correct Marks : 4 Wrong Marks : 0

दिखाये गये मीटर ब्रिज प्रयोग में S एक मानक प्रतिरोधक है तथा R एक प्रतिरोधक तार है। दी हुई स्थिति में संतुलन बिन्दु के लिये लम्बाई $l = 25 \text{ cm}$ है। यदि अब R की जगह इसी पदार्थ से बना एक दूसरा तार, जिसकी लम्बाई R की आधी और जिसका व्यास भी R का आधा हो, लगा दिया जाय तो नये संतुलन बिन्दु के लिये लम्बाई l' का मान (cm में) होगा _____.

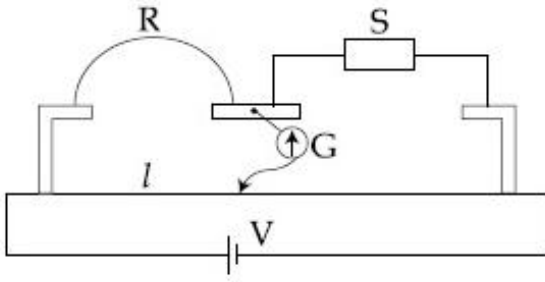

Response Type: Numeric

Evaluation Required For SA: Yes

Show Word Count: Yes

Answers Type: Range

Possible Answers :

40 to 40

Question Number : 23 Question Type : SA

Correct Marks : 4 Wrong Marks : 0

એક મીટરબ્રીજના પ્રયોગમાં S એક પ્રમાણિત અવરોધ છે. R એક અવરોધ તાર છે. એવું જોવા મળે છે કે સમતોલન લંબાઈ $l = 25 \text{ cm}$ છે. જો R ને બદલે તેનાથી અડધી લંબાઈ અને અડધો વ્યાસ ધરાવતા પરંતુ R ના જ દ્રવ્યમાન બનેલા તારથી બદલવામાં આવે તો હવે સમતોલન અંતર l' (cm માં) _____ થશે.

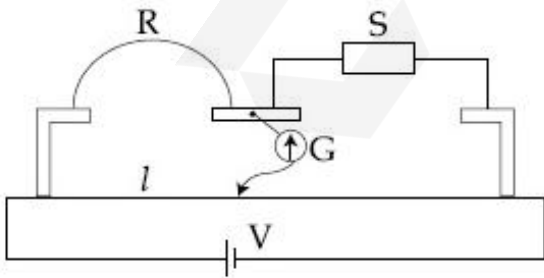

Response Type: Numeric

Evaluation Required For SA: Yes

Show Word Count: Yes

Answers Type: Range

Possible Answers :

40 to 40

Question Number : 24 Question Type : SA

Correct Marks : 4 Wrong Marks : 0

In a Young's double slit experiment 15 fringes are observed on a small portion of the screen when light of wavelength 500 nm is used. Ten fringes are observed on the same section of the screen when another light source of wavelength λ is used. Then the value of λ is (in nm)

_____.

Response Type: Numeric

Evaluation Required For SA: Yes

Show Word Count: Yes

Answers Type: Range

Possible Answers :

750 to 750

Question Number : 24 Question Type : SA

Correct Marks : 4 Wrong Marks : 0

यंग के द्विझिरी प्रयोग में यदि प्रकाश का तरंगदैर्घ्य 500 nm हो तो पर्दे के एक छोटे भाग में 15 फ्रिन्जें देखी जाती है। यदि प्रकाश का तरंगदैर्घ्य λ हो तो पर्दे के उसी भाग में दिखने वाली फ्रिन्जों की संख्या 10 हो जाती है। λ का मान (nm में) है _____.

Response Type: Numeric

Evaluation Required For SA: Yes

Show Word Count: Yes

Answers Type: Range

Possible Answers :

750 to 750

Question Number : 24 Question Type : SA

Correct Marks : 4 Wrong Marks : 0

500 nm तरंगलंबाईનો ઉપયોગ કરી એક યંગના ડબલ-સ્લિટના પ્રયોગમાં પડદા પરના નાના ભાગમાં 15 શલાકાઓ જોવામાં આવે છે. જ્યારે λ તરંગલંબાઈ ધરાવતો બીજો પ્રકાશ ઉદ્ગમ વાપરવામાં આવે છે ત્યારે પડદાના આ જ વિભાગમાં 10 શલાકાઓ જોવા મળે છે, તો λ નું મૂલ્ય (nm માં) _____ છે.

Response Type: Numeric

Evaluation Required For SA: Yes

Show Word Count: Yes

Answers Type: Range

Possible Answers :

750 to 750

Question Number : 25 Question Type : SA

Correct Marks : 4 Wrong Marks : 0

The circuit shown below is working as a 8 V dc regulated voltage source. When 12 V is used as input, the power dissipated (in mW) in each diode is; (considering both zener diodes are identical) _____.

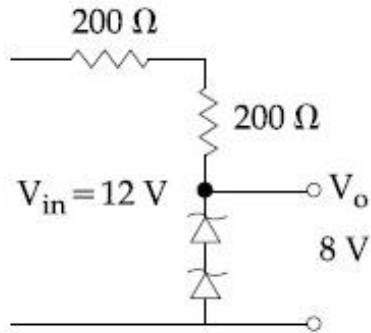

Response Type: Numeric

Evaluation Required For SA: Yes

Show Word Count: Yes

Answers Type: Range

Possible Answers :

12 to 12

Question Number : 25 Question Type : SA

Correct Marks : 4 Wrong Marks : 0

दिखाया गया परिपथ 8 V के दिष्ट धारा नियमित वोल्टता स्रोत की भाँति कार्य करता है। जब इसमें 12 V की निवेशी वोल्टता लगायी जाती है तो प्रत्येक डायोड में होने वाली ऊर्जा की क्षति mW में होगी : (दोनों जीनर डायोड एकसमान हैं) _____.

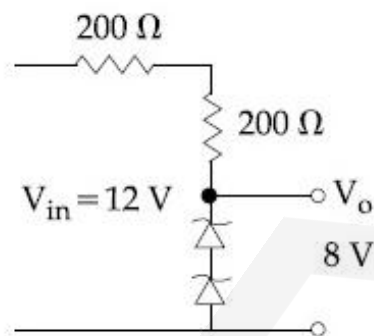

Response Type: Numeric

Evaluation Required For SA: Yes

Show Word Count: Yes

Answers Type: Range

Possible Answers :

12 to 12

Question Number : 25 Question Type : SA

Correct Marks : 4 Wrong Marks : 0

નીચે દર્શાવેલ પરિપથ એક 8 V ના dc રેગ્યુલેટેડ (નિયમિત) વોલ્ટેજ ઉદ્ભવ તરીકે વર્તે છે, જ્યારે ઇનપુટ તરીકે 12 V વાપરવામાં આવે છે ત્યારે દરેક ડાયોડમાં વિખેરીત થતો પાવર (કાર્યત્વર) (mW માં) _____ થશે. (બંને ઝેનર ડાયોડને એકસમાન ગણો)

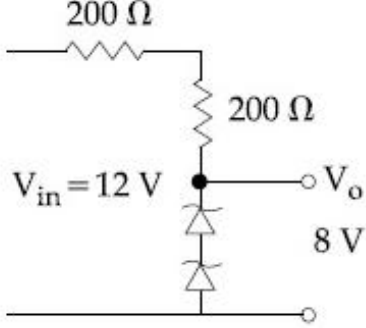

Response Type: Numeric

Evaluation Required For SA: Yes

Show Word Count: Yes

Answers Type: Range

Possible Answers :

12 to 12

Chemistry

Section Id :	40503685
Section Number :	2
Section type :	Online
Mandatory or Optional:	Mandatory
Number of Questions:	25
Number of Questions to be attempted:	25
Section Marks:	100

Sub-Section Number:	1
Sub-Section Id:	405036142
Question Shuffling Allowed :	Yes

Question Number : 26 Question Type : MCQ Option Shuffling : Yes

Correct Marks : 4 Wrong Marks : 1

The true statement amongst the following is :

Options :

S is a function of temperature but ΔS

1. is not a function of temperature.

Both ΔS and S are functions of
2. temperature.

Both S and ΔS are not functions of
3. temperature.

S is not a function of temperature but
4. ΔS is a function of temperature.

Question Number : 26 Question Type : MCQ Option Shuffling : Yes
Correct Marks : 4 Wrong Marks : 1

निम्नलिखित कथनों में से सही कथन है :

Options :

1. S ताप का एक फलन है परन्तु ΔS ताप का एक फलन नहीं है।

2. दोनों ΔS तथा S ताप के फलन हैं।

3. दोनों S तथा ΔS ताप के फलन नहीं है।

4. S ताप का एक फलन नहीं है परन्तु, ΔS ताप का एक फलन है।

Question Number : 26 Question Type : MCQ Option Shuffling : Yes
Correct Marks : 4 Wrong Marks : 1

नीचे आपेला विधानो पैकी सायुं विधान शोधो :

Options :

1. S अे तापमान नुं विधेय छे परंतु ΔS अे तापमान नुं विधेय नथी.

2. ΔS અને S બંને તાપમાન ના વિધેયો છે.

3. S અને ΔS બંને તાપમાન ના વિધેયો નથી.

4. S એ તાપમાનનું વિધેય નથી પરંતુ ΔS એ તાપમાનનું વિધેય છે.

Question Number : 27 Question Type : MCQ Option Shuffling : Yes
Correct Marks : 4 Wrong Marks : 1

The solubility product of $\text{Cr}(\text{OH})_3$ at 298 K is 6.0×10^{-31} . The concentration of hydroxide ions in a saturated solution of $\text{Cr}(\text{OH})_3$ will be :

Options :

1. $(18 \times 10^{-31})^{1/4}$

2. $(4.86 \times 10^{-29})^{1/4}$

3. $(2.22 \times 10^{-31})^{1/4}$

4. $(18 \times 10^{-31})^{1/2}$

Question Number : 27 Question Type : MCQ Option Shuffling : Yes
Correct Marks : 4 Wrong Marks : 1

298 K પર, $\text{Cr}(\text{OH})_3$ का विलेयता गुणांक 6.0×10^{-31} है। $\text{Cr}(\text{OH})_3$ के एक संतृप्त विलयन में हाइड्रॉक्साइड आयन की सान्द्रता होगी :

Options :

1. $(18 \times 10^{-31})^{1/4}$

2. $(4.86 \times 10^{-29})^{1/4}$

3. $(2.22 \times 10^{-31})^{1/4}$

4. $(18 \times 10^{-31})^{1/2}$

Question Number : 27 Question Type : MCQ Option Shuffling : Yes
Correct Marks : 4 Wrong Marks : 1

298 K પર $\text{Cr}(\text{OH})_3$ ની દ્રાવ્યતા ગુણાકાર 6.0×10^{-31} છે તો $\text{Cr}(\text{OH})_3$ ના સંતૃપ્ત દ્રાવણમાં હાઈડ્રોક્સાઈડ આયનની સાંદ્રતા શું હશે?

Options :

1. $(18 \times 10^{-31})^{1/4}$

2. $(4.86 \times 10^{-29})^{1/4}$

3. $(2.22 \times 10^{-31})^{1/4}$

4. $(18 \times 10^{-31})^{1/2}$

Question Number : 28 Question Type : MCQ Option Shuffling : Yes
Correct Marks : 4 Wrong Marks : 1

Amongst the following, the form of water with the lowest ionic conductance at 298 K is :

Options :

1. sea water

2. water from a well

saline water used for intravenous

3. injection

4. distilled water

Question Number : 28 Question Type : MCQ Option Shuffling : Yes
Correct Marks : 4 Wrong Marks : 1

298 K पर वह जल का प्रारूप, जिसकी आयनिक चालकता सबसे कम हो, निम्नलिखित में से है :

Options :

1. समुद्र जल

2. कुँए का जल

3. लवण जल जिसका अंतःशिरा इन्जेक्शन में प्रयुक्त होता है

4. आसवित जल

Question Number : 28 Question Type : MCQ Option Shuffling : Yes
Correct Marks : 4 Wrong Marks : 1

नीचे आपेला पाएलीना विविध सवइपो मां कया अेकमां
298 K पर आयनिक वाहकता सौथी ओछी लशे?

Options :

1. दरिथानुं पाएली

2. કુવામાનું પાણી

નસની અંદર અપાતા ઈન્જેક્શન માટે સલાઈન

3. પાણી

4. નિસ્ચંદિત પાણી

Question Number : 29 Question Type : MCQ Option Shuffling : Yes
Correct Marks : 4 Wrong Marks : 1

A mixture of gases O_2 , H_2 and CO are taken in a closed vessel containing charcoal. The graph that represents the correct behaviour of pressure with time is :

Options :

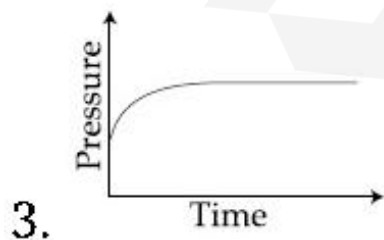
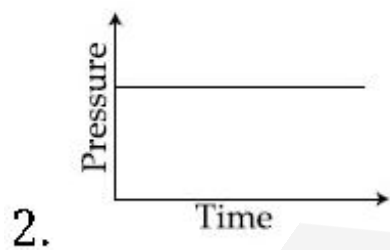
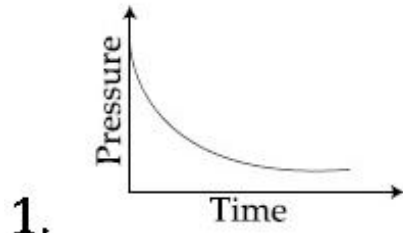

4.

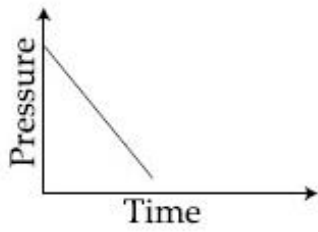

Question Number : 29 Question Type : MCQ Option Shuffling : Yes
 Correct Marks : 4 Wrong Marks : 1

O_2 , H_2 तथा CO गैसों के एक मिश्रण को एक बन्द पात्र में लिया जाता है जिसमें चारकोल है। आलेख जो, दाब का समय के साथ सही व्यवहार निरूपित करता है, है :

Options :

1.

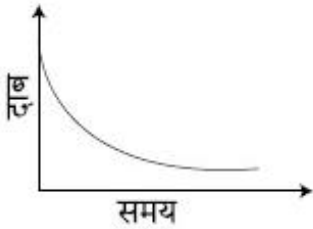

2.

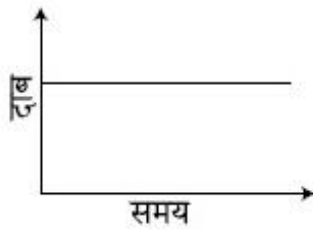

3.

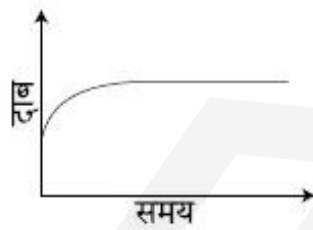

4.

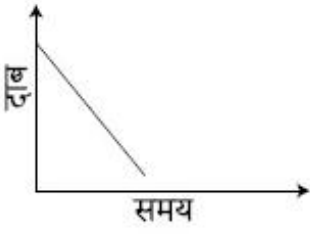

Question Number : 29 Question Type : MCQ Option Shuffling : Yes
Correct Marks : 4 Wrong Marks : 1

ચારકોલ ધરાવતા એક બંધ પાત્રમાં વાયુઓ O_2 , H_2 અને CO નું મિશ્રણ લેવામાં આવ્યું. નીચે આપેલા પૈકી કયા એક આલેખમાં દબાણ સાથે સમયની સાચી વર્તણૂકનું નિર્દેશન કરે છે ?

Options :

1.

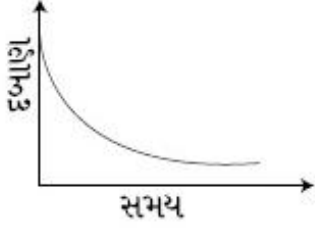

2.

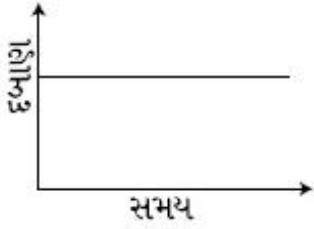

3.

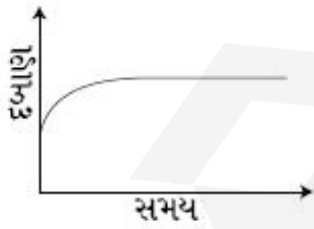

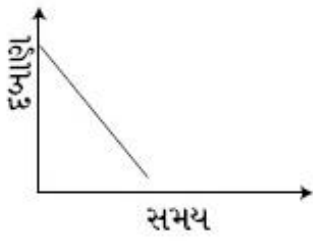

4.

Question Number : 30 Question Type : MCQ Option Shuffling : Yes
Correct Marks : 4 Wrong Marks : 1

નીચે આપેલી આકૃતિમાં પ્રક્રિયક A (ચોરસ વડે દર્શાવેલ છે) જે નિપજ B (ગોળ વડે દર્શાવેલ છે) સાથે સંતુલન માં છે. તો સંતુલન અચળાંક શું છે?

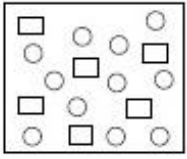

Options :

1. 2

2. 4

3. 8

4. 1

Question Number : 30 Question Type : MCQ Option Shuffling : Yes
Correct Marks : 4 Wrong Marks : 1

In the figure shown below reactant A (represented by square) is in equilibrium with product B (represented by circle). The equilibrium constant is :

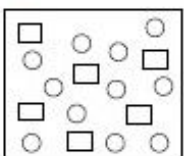

Options :

1. 2

2. 4

3. 8

4. 1

**Question Number : 30 Question Type : MCQ Option Shuffling : Yes
Correct Marks : 4 Wrong Marks : 1**

नीचे दिये गये आकृति में, अभिकारक A (वर्ग द्वारा निरूपित) उत्पाद B (वृत्त द्वारा निरूपित) के साथ साम्यावस्था में है। साम्य स्थिरांक है :

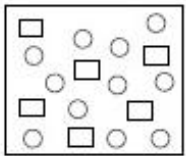

Options :

1. 2

2. 4

3. 8

4. 1

**Question Number : 31 Question Type : MCQ Option Shuffling : Yes
Correct Marks : 4 Wrong Marks : 1**

The number of sp^2 hybrid orbitals in a molecule of benzene is :

Options :

1. 6

2. 12

3. 18

4. 24

Question Number : 31 Question Type : MCQ Option Shuffling : Yes
Correct Marks : 4 Wrong Marks : 1

बेन्जीन के एक अणु में sp^2 संकर कक्षकों की संख्या है :

Options :

1. 6

2. 12

3. 18

4. 24

Question Number : 31 Question Type : MCQ Option Shuffling : Yes
Correct Marks : 4 Wrong Marks : 1

बेन्जिनना आणुमां रलेली sp^2 संकृत कक्षकनी संख्या शोधो.

Options :

1. 6

2. 12

3. 18

4. 24

Question Number : 32 Question Type : MCQ Option Shuffling : Yes
Correct Marks : 4 Wrong Marks : 1

The first and second ionisation enthalpies of a metal are 496 and 4560 kJ mol⁻¹, respectively. How many moles of HCl and H₂SO₄, respectively, will be needed to react completely with 1 mole of the metal hydroxide ?

Options :

1. 1 and 1

2. 2 and 0.5

3. 1 and 2

4. 1 and 0.5

Question Number : 32 Question Type : MCQ Option Shuffling : Yes
Correct Marks : 4 Wrong Marks : 1

एक धातु की प्रथम तथा द्वितीय आयतन एन्थैल्पियाँ क्रमशः 496 तथा 4560 kJ mol⁻¹ है। एक मोल धातु हाइड्राक्साइड से पूर्णतया अभिक्रिया के लिए HCl तथा H₂SO₄, के कितने मोलों की आवश्यकता होगी ?

Options :

1. 1 तथा 1

2. 2 तथा 0.5

3. 1 तथा 2

4. 1 तथा 0.5

Question Number : 32 Question Type : MCQ Option Shuffling : Yes
Correct Marks : 4 Wrong Marks : 1

એક ધાતુની પ્રથમ અને દ્વિતીય આયનિકરણ એન્થાલ્પી અનુક્રમે 496 અને 4560 kJ mol⁻¹ છે. 1 mole ધાતુ હાઈડ્રોક્સાઈડ સાથે સંપૂર્ણપણે પ્રક્રિયા કરવા, અનુક્રમે કેટલા મોલ HCl અને H₂SO₄ ની જરૂર પડશે?

Options :

1. 1 અને 1

2. 2 અને 0.5

3. 1 અને 2

4. 1 અને 0.5

Question Number : 33 Question Type : MCQ Option Shuffling : Yes
Correct Marks : 4 Wrong Marks : 1

5 g of zinc is treated separately with an excess of

- (a) dilute hydrochloric acid and
- (b) aqueous sodium hydroxide.

The ratio of the volumes of H_2 evolved in these two reactions is :

Options :

- 1. 1 : 2
- 2. 1 : 1
- 3. 2 : 1
- 4. 1 : 4

Question Number : 33 Question Type : MCQ Option Shuffling : Yes

Correct Marks : 4 Wrong Marks : 1

5 g जिंक को अलग-अलग

- (a) तनु हाइड्रोक्लोरिक अम्ल तथा
- (b) जलीय सोडियम हाइड्रॉक्साइड के आधिक्य के साथ अभिक्रियित किया जाता है।

इन दोनों अभिक्रियाओं में उत्सर्जित H_2 के आयतनों का अनुपात है :

Options :

- 1. 1 : 2
- 2. 1 : 1
- 3. 2 : 1

4. 1 : 4

Question Number : 33 Question Type : MCQ Option Shuffling : Yes

Correct Marks : 4 Wrong Marks : 1

5 g ઝિંક ને વધુ પડતા

(a) મંદ હાઈડ્રોકલોરીક એસિડ અને

(b) જલીય સોડિયમ હાઈડ્રોક્સાઈડ

સાથે જુદા-જુદા ગરમ કરતા આ બંને પ્રક્રિયામાં નિકળતા

H_2 ના કદનો ગુણોત્તર શોધો :

Options :

1. 1 : 2

2. 1 : 1

3. 2 : 1

4. 1 : 4

Question Number : 34 Question Type : MCQ Option Shuffling : Yes

Correct Marks : 4 Wrong Marks : 1

Among the statements (a)-(d), the correct ones are :

(a) Lithium has the highest hydration enthalpy among the alkali metals.

(b) Lithium chloride is insoluble in pyridine.

(c) Lithium cannot form ethynide upon its reaction with ethyne.

(d) Both lithium and magnesium react slowly with H_2O .

Options :

1. (a) and (d) only
2. (b) and (c) only
3. (a), (c) and (d) only
4. (a), (b) and (d) only

Question Number : 34 Question Type : MCQ Option Shuffling : Yes
Correct Marks : 4 Wrong Marks : 1

कथनों (a)–(d) में से सही कथन हैं :

- (a) क्षार-धातुओं में लिथियम की जलयोजना एन्थैल्पी सबसे अधिक है।
- (b) लीथियम क्लोराइड पिरिडीन में अविलेय है।
- (c) लीथियम एथाइन से अभिक्रिया करके एथाइनाइड नहीं बना सकता है।
- (d) लीथियम तथा मैग्नीशियम दोनों जल के साथ धीरे-धीरे अभिक्रिया करते हैं।

Options :

1. (a) तथा (d) मात्र
2. (b) तथा (c) मात्र
3. (a), (c) तथा (d) मात्र
4. (a), (b) तथा (d) मात्र

Question Number : 34 Question Type : MCQ Option Shuffling : Yes
Correct Marks : 4 Wrong Marks : 1

આપેલા વિધાનો (a)-(d) માં સાચું એક વિધાન શોધો :

- (a) આલ્કલી ધાતુઓમાં લિથિયમની જલયોજન ઉષ્મા સૌથી વધુ છે.
- (b) લિથિયમ ક્લોરાઇડ પિરિડિનમાં અદ્રાવ્ય છે.
- (c) લિથિયમની ઈથાઇન સાથેની પ્રક્રિયામાં ઈથીનાઇડ બનાવતો નથી.
- (d) લિથિયમ અને મેગ્નેશિયમ બંને H_2O સાથે ધીમી પ્રક્રિયા કરે છે.

Options :

1. ફક્ત(a) અને (d)
2. ફક્ત (b) અને (c)
3. ફક્ત (a), (c) અને (d)
4. ફક્ત (a), (b) અને (d)

Question Number : 35 Question Type : MCQ Option Shuffling : Yes

Correct Marks : 4 Wrong Marks : 1

The reaction of $H_3N_3B_3Cl_3$ (A) with $LiBH_4$ in tetrahydrofuran gives inorganic benzene (B). Further, the reaction of (A) with (C) leads to $H_3N_3B_3(Me)_3$. Compounds (B) and (C) respectively, are :

Options :

1. Diborane and $MeMgBr$
2. Borazine and $MeMgBr$

3. Boron nitride and MeBr

4. Borazine and MeBr

Question Number : 35 Question Type : MCQ Option Shuffling : Yes

Correct Marks : 4 Wrong Marks : 1

$H_3N_3B_3Cl_3$ (A) की टेट्राहाइड्रोफ्यूरान में $LiBH_4$ के साथ अभिक्रिया अकार्बनिक बेन्जीन (B) देती है।

आगे (A) की (C) के साथ अभिक्रिया $H_3N_3B_3(Me)_3$ देती है। यौगिक (B) तथा (C) क्रमशः हैं :

Options :

1. डाइबोरेन तथा $MeMgBr$

2. बोरैजीन तथा $MeMgBr$

3. बोरॉन नाइट्राइड तथा $MeBr$

4. बोरैजीन तथा $MeBr$

Question Number : 35 Question Type : MCQ Option Shuffling : Yes

Correct Marks : 4 Wrong Marks : 1

$H_3N_3B_3Cl_3$ (A) ની ટેટ્રાહાઈડ્રોફ્યુરેન માં ના $LiBH_4$ સાથે પ્રક્રિયા કરતા અકાર્બનિક બેન્ઝિન (B) આપે છે.

વધુમાં (A) ની (C) સાથે પ્રક્રિયા કરતા $H_3N_3B_3(Me)_3$ આપે છે. તો સંયોજન (B) અને (C) અનુક્રમે શોધો.

Options :

1. ડાયબોરેન અને $MeMgBr$

2. બોરેઝિન અને $MeMgBr$

3. બોરોનનાઇટ્રાઇડ અને MeBr

4. બોરેઝિન અને MeBr

Question Number : 36 Question Type : MCQ Option Shuffling : Yes
Correct Marks : 4 Wrong Marks : 1

The isomer(s) of $[\text{Co}(\text{NH}_3)_4\text{Cl}_2]$ that has/
have a Cl - Co - Cl angle of 90° , is/are :

Options :

1. trans only

2. cis only

3. cis and trans

4. meridional and trans

Question Number : 36 Question Type : MCQ Option Shuffling : Yes
Correct Marks : 4 Wrong Marks : 1

$[\text{Co}(\text{NH}_3)_4\text{Cl}_2]$ के समावयवी जिसमें/जिनमें
Cl - Co - Cl कोण 90° का है, है/हैं :

Options :

1. ट्रान्स मात्र

2. सिस मात्र

3. सिस तथा ट्रान्स

4. रेखांशिक तथा ट्रान्स

Question Number : 36 Question Type : MCQ Option Shuffling : Yes
Correct Marks : 4 Wrong Marks : 1

$[\text{Co}(\text{NH}_3)_4\text{Cl}_2]$ ના સમઘટક(કો) માં $\text{Cl}-\text{Co}-\text{Cl}$
ખૂણો 90° નો છે, તે શોધો :

Options :

1. ફક્ત ટ્રાન્સ

2. ફક્ત સીસ

3. સીસ અને ટ્રાન્સ

4. મેરીડોનિઅલ અને ટ્રાન્સ

Question Number : 37 Question Type : MCQ Option Shuffling : Yes
Correct Marks : 4 Wrong Marks : 1

The correct order of the spin-only magnetic moments of the following complexes is :

(I) $[\text{Cr}(\text{H}_2\text{O})_6]\text{Br}_2$

(II) $\text{Na}_4[\text{Fe}(\text{CN})_6]$

(III) $\text{Na}_3[\text{Fe}(\text{C}_2\text{O}_4)_3]$ ($\Delta_0 > P$)

(IV) $(\text{Et}_4\text{N})_2[\text{CoCl}_4]$

Options :

1. (III) > (I) > (IV) > (II)

2. (I) > (IV) > (III) > (II)

3. (II) \approx (I) > (IV) > (III)

4. (III) > (I) > (II) > (IV)

Question Number : 37 Question Type : MCQ Option Shuffling : Yes

Correct Marks : 4 Wrong Marks : 1

निम्नलिखित संकुलों के प्रचक्रण-मात्र चुम्बकीय आघूर्णों का सही क्रम है :

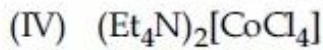
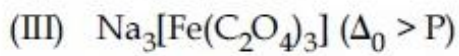
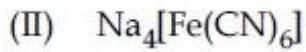
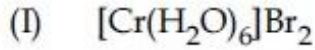

Options :

1. (III) > (I) > (IV) > (II)

2. (I) > (IV) > (III) > (II)

3. (II) \approx (I) > (IV) > (III)

4. (III) > (I) > (II) > (IV)

Question Number : 37 Question Type : MCQ Option Shuffling : Yes

Correct Marks : 4 Wrong Marks : 1

नीचे आपेला संकुलानी इकत रूपीन चुम्बकीय आकमात्रा नो साथे कम शोधो :

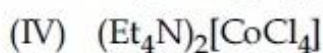
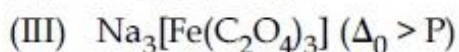
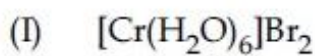

Options :

1. (III) > (I) > (IV) > (II)

2. (I) > (IV) > (III) > (II)

3. (II) \approx (I) > (IV) > (III)

4. (III) > (I) > (II) > (IV)

Question Number : 38 Question Type : MCQ Option Shuffling : Yes

Correct Marks : 4 Wrong Marks : 1

Biochemical Oxygen Demand (BOD) is the amount of oxygen required (in ppm) :

Options :

1. for sustaining life in a water body.

for the photochemical breakdown of waste present in 1 m³ volume of a

2. water body.

by bacteria to break-down organic waste in a certain volume of a water

3. sample.

by anaerobic bacteria to breakdown inorganic waste present in a water

4. body.

Question Number : 38 Question Type : MCQ Option Shuffling : Yes

Correct Marks : 4 Wrong Marks : 1

जैवरासायनिक ऑक्सीजन माँग (BOD) आवश्यक ऑक्सीजन की मात्रा (ppm में) है :

Options :

1. एक जलाशय में जीवन को दीर्घकालीन बनाने के लिए।

2. एक जलाशय के 1 m^3 आयतन में उपस्थित अपशिष्ट के प्रकाशरासायनिक भंजन के लिए।

3. एक जल-प्रतिदर्श के एक निश्चित आयतन में बैक्टीरिया द्वारा कार्बनिक अपशिष्ट के भंजन के लिए।

4. अवायवीय बैक्टीरिया द्वारा एक जलाशय में उपस्थित अकार्बनिक अपशिष्ट के भंजन के लिए।

Question Number : 38 Question Type : MCQ Option Shuffling : Yes

Correct Marks : 4 Wrong Marks : 1

ऑक्सिजननी मात्रा (ppm मां) बायोकेमिकल ऑक्सिजन डीमांड मां नीचेनामांथी अेकमां ज़री छे.

Options :

1. जलस्रोतमां जलन टकावी राभवा

2. 1 m^3 कदवाणा जलस्रोतमां कथराना प्रकाशरासायणिक विघटन माटे

3. पाणीना थोक्स कदना नभूनामां कार्बनिक कथरानुं बैक्टीरिया द्वारा विघटन

જળસ્ત્રોતમાં હાજર અકાર્બનિક કચરાનું

4. એનએરોબિક બેક્ટેરિયા વડે વિઘટન

Question Number : 39 Question Type : MCQ Option Shuffling : Yes

Correct Marks : 4 Wrong Marks : 1

The decreasing order of basicity of the following amines is :

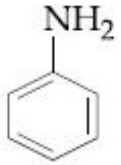

(I)

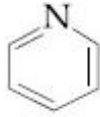

(II)

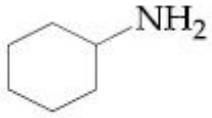

(III)

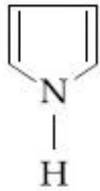

(IV)

Options :

1. (III) > (II) > (I) > (IV)

2. (III) > (I) > (II) > (IV)

3. (II) > (III) > (IV) > (I)

4. (I) > (III) > (IV) > (II)

Question Number : 39 Question Type : MCQ Option Shuffling : Yes

Correct Marks : 4 Wrong Marks : 1

निम्नलिखित ऐमीनों की क्षारकता का घटता क्रम है :

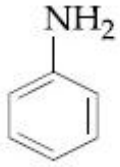

(I)

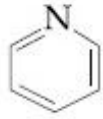

(II)

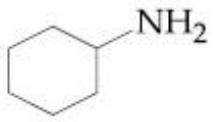

(III)

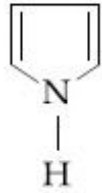

(IV)

Options :

1. (III) > (II) > (I) > (IV)
2. (III) > (I) > (II) > (IV)
3. (II) > (III) > (IV) > (I)
4. (I) > (III) > (IV) > (II)

Question Number : 39 Question Type : MCQ Option Shuffling : Yes
Correct Marks : 4 Wrong Marks : 1

नीचे आपेला ऐमाँनोमां अेऑरुतानो धटतो कुम शोधो :

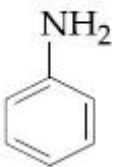

(I)

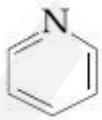

(II)

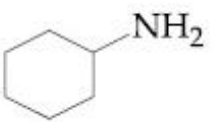

(III)

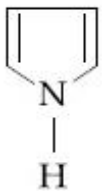

(IV)

Options :

1. (III) > (II) > (I) > (IV)

2. (III) > (I) > (II) > (IV)

3. (II) > (III) > (IV) > (I)

4. (I) > (III) > (IV) > (II)

Question Number : 40 Question Type : MCQ Option Shuffling : Yes

Correct Marks : 4 Wrong Marks : 1

Which of the following has the shortest
C-Cl bond ?

Options :

1. $\text{Cl}-\text{CH}=\text{CH}_2$

2. $\text{Cl}-\text{CH}=\text{CH}-\text{NO}_2$

3. $\text{Cl}-\text{CH}=\text{CH}-\text{CH}_3$

4. $\text{Cl}-\text{CH}=\text{CH}-\text{OCH}_3$

Question Number : 40 Question Type : MCQ Option Shuffling : Yes

Correct Marks : 4 Wrong Marks : 1

निम्नलिखित में से किसमें सबसे छोटा C-Cl आबंध
है?

Options :

1. $\text{Cl}-\text{CH}=\text{CH}_2$

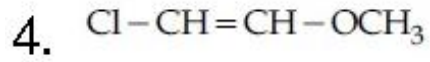
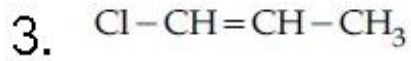
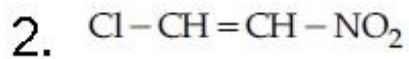

Question Number : 40 Question Type : MCQ Option Shuffling : Yes

Correct Marks : 4 Wrong Marks : 1

નીચેના માંથી કોનો C-Cl બંધ ટૂંકામાં ટૂંકો છે?

Options :

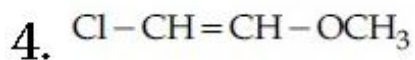
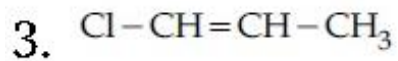
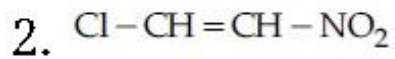
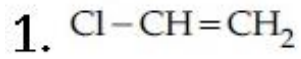

Question Number : 41 Question Type : MCQ Option Shuffling : Yes

Correct Marks : 4 Wrong Marks : 1

A, B and C are three biomolecules. The results of the tests performed on them are given below :

	Molisch's Test	Barfoed Test	Biuret Test
A	Positive	Negative	Negative
B	Positive	Positive	Negative
C	Negative	Negative	Positive

A, B and C are respectively :

Options :

1. A = Lactose, B = Glucose, C = Albumin
2. A = Glucose, B = Fructose, C = Albumin
3. A = Lactose, B = Glucose, C = Alanine
4. A = Lactose, B = Fructose, C = Alanine

Question Number : 41 Question Type : MCQ Option Shuffling : Yes

Correct Marks : 4 Wrong Marks : 1

A, B तथा C तीन जैवअणु हैं। उनपर किये गये परीक्षणों का परिणाम नीचे दिये गये हैं :

	मोलिश परीक्षण	बाफोर्ड परीक्षण	बाइयूरेट परीक्षण
A	सकारात्मक	नकारात्मक	नकारात्मक
B	सकारात्मक	सकारात्मक	नकारात्मक
C	नकारात्मक	नकारात्मक	सकारात्मक

A, B तथा C क्रमशः हैं :

Options :

1. A = लैक्टोस, B = ग्लूकोस, C = ऐल्ब्यूमिन

2. A = ગ્લૂકોસ, B = ફ્રુક્ટોઝ, C = એલ્બૂમિન

3. A = લૈક્ટોસ, B = ગ્લૂકોસ, C = એલાનિન

4. A = લૈક્ટોસ, B = ફ્રુક્ટોઝ, C = એલાનિન

Question Number : 41 Question Type : MCQ Option Shuffling : Yes

Correct Marks : 4 Wrong Marks : 1

A, B અને C ત્રણેય જૈવઅણુઓ છે. તેમની ઉપર કસોટી કર્યાબાદ તેના પરિણામો નીચે આપેલા છે.

	મોલિશ કસોટી	બેફોર્ડ કસોટી	બાયયુરેટ કસોટી
A	હકારાત્મક	નકારાત્મક	નકારાત્મક
B	હકારાત્મક	હકારાત્મક	નકારાત્મક
C	નકારાત્મક	નકારાત્મક	હકારાત્મક

A, B અને C અનુક્રમે :

Options :

1. A = લેક્ટોઝ, B = ગ્લુકોઝ, C = આલ્બુમીન

2. A = ગ્લુકોઝ, B = ફ્રુક્ટોઝ, C = આલ્બુમીન

3. A = લેક્ટોઝ, B = ગ્લુકોઝ, C = એલેનાઈન

4. A = લેક્ટોઝ, B = ફ્રુક્ટોઝ, C = એલેનાઈન

Question Number : 42 Question Type : MCQ Option Shuffling : Yes

Correct Marks : 4 Wrong Marks : 1

Which polymer has 'chiral' monomer(s) ?

Options :

1. Neoprene
2. Buna-N
3. Nylon 6, 6
4. PHBV

Question Number : 42 Question Type : MCQ Option Shuffling : Yes

Correct Marks : 4 Wrong Marks : 1

बहुलक जिसके एकलक 'काइरल' हैं, है :

Options :

1. नियोप्रीन
2. ब्यूना-N
3. नाइलॉन 6, 6
4. PHBV (पी.एच.बी.वी.)

Question Number : 42 Question Type : MCQ Option Shuffling : Yes

Correct Marks : 4 Wrong Marks : 1

કયો પોલિમર કીરાલ મોનોમર ધરાવે છે?

Options :

1. નિયોપ્રિન

2. व्युत्पन्न-N

3. नायलोन, 6, 6

4. PHBV (पीएचबीवी)

Question Number : 43 Question Type : MCQ Option Shuffling : Yes
Correct Marks : 4 Wrong Marks : 1

Which of the following reactions will not produce a racemic product ?

Options :

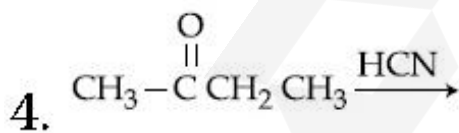
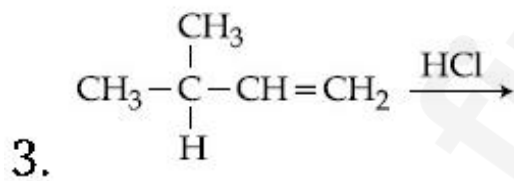
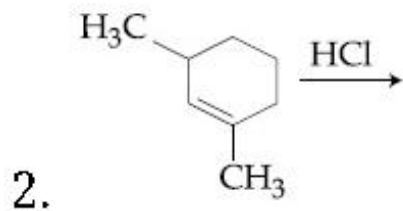
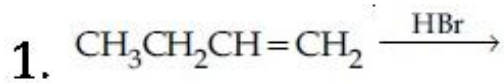

Question Number : 43 Question Type : MCQ Option Shuffling : Yes
Correct Marks : 4 Wrong Marks : 1

निम्नलिखित अभिक्रियाओं में से कौन एक रैसिमिक उत्पाद नहीं देगी ?

Options :

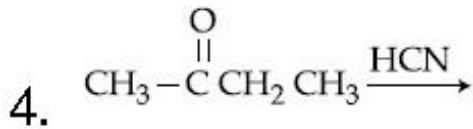
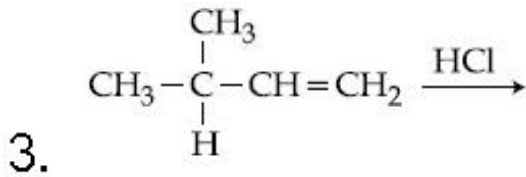
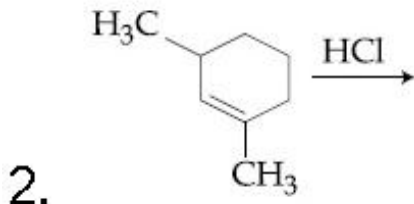
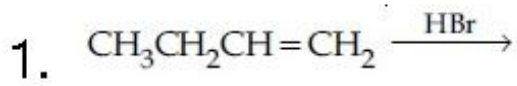

Question Number : 43 Question Type : MCQ Option Shuffling : Yes
Correct Marks : 4 Wrong Marks : 1

नीचेना आपेल प्रक्रियाओमां कठ रेसेमिक नीपज आपरो
नहीं?

Options :

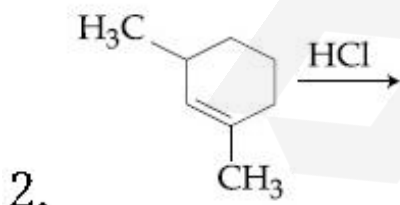
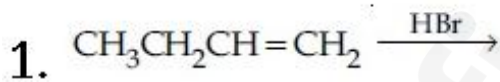

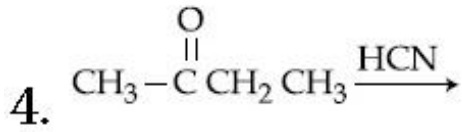
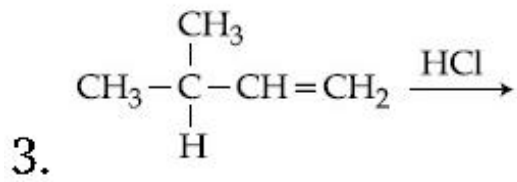

Question Number : 44 Question Type : MCQ Option Shuffling : Yes
 Correct Marks : 4 Wrong Marks : 1

In the following reaction A is :

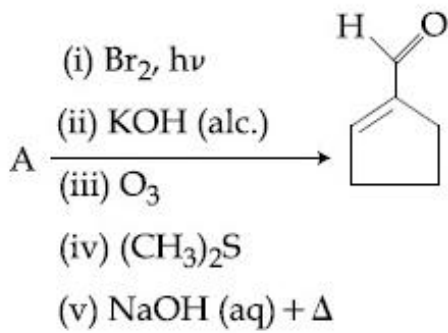

Options :

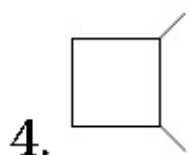
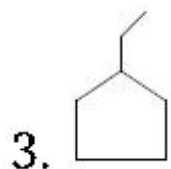
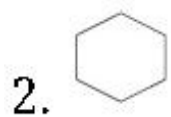
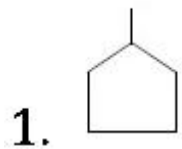

Question Number : 44 Question Type : MCQ Option Shuffling : Yes

Correct Marks : 4 Wrong Marks : 1

निम्नलिखित अभिक्रिया में A है :

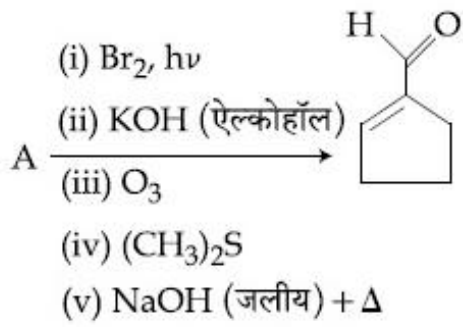

Options :

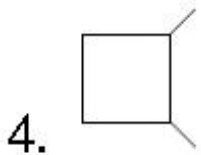
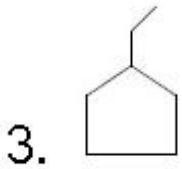
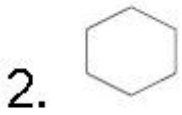
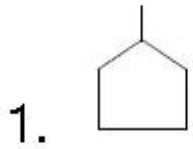

Question Number : 44 Question Type : MCQ Option Shuffling : Yes

Correct Marks : 4 Wrong Marks : 1

નીચે આપેલી પ્રક્રિયામાં A શોધો :

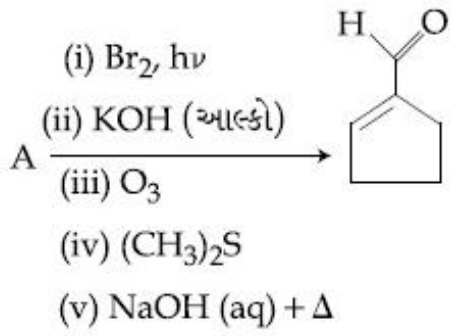

Options :

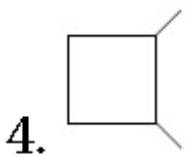
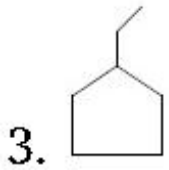
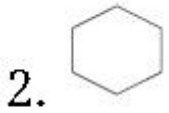
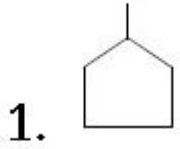

Question Number : 45 Question Type : MCQ Option Shuffling : Yes
Correct Marks : 4 Wrong Marks : 1

Consider the following reactions,

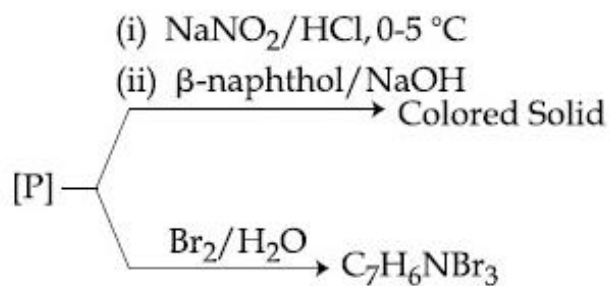

The compound [P] is :

Options :

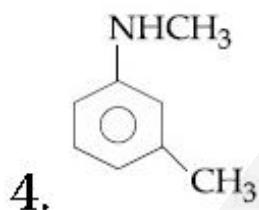
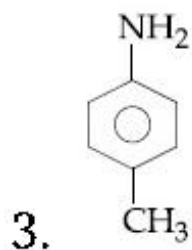
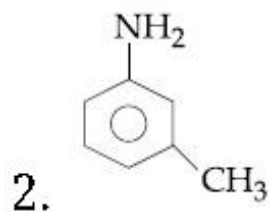
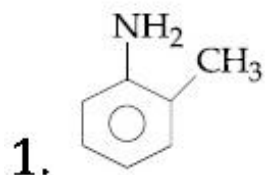

Question Number : 45 Question Type : MCQ Option Shuffling : Yes

Correct Marks : 4 Wrong Marks : 1

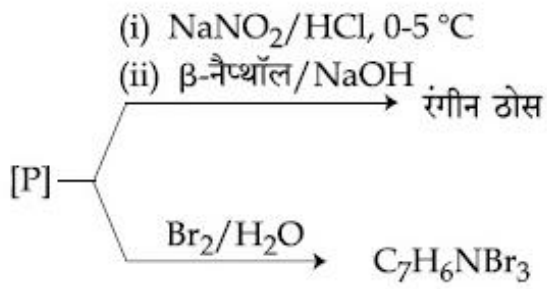

यौगिक [P] है :

Options :

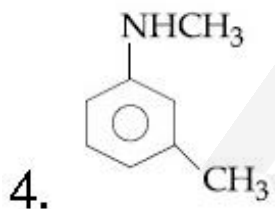
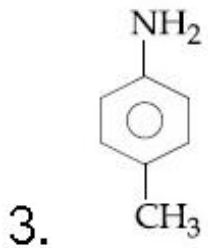
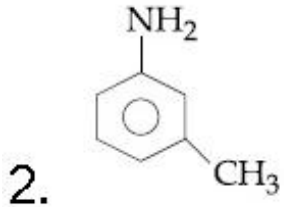
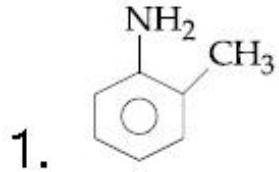

નીચે આપેલી પ્રક્રિયા ધ્યાનમાં લો :

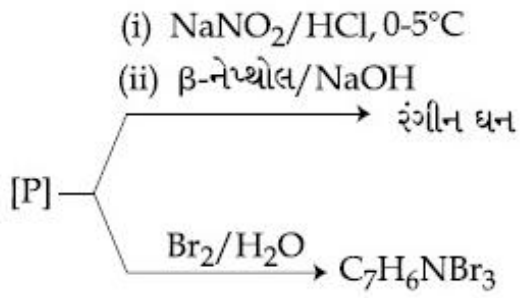

સંયોજન [P] શોધો :

Options :

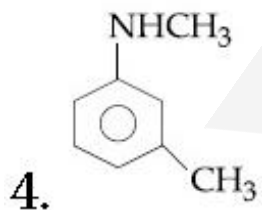
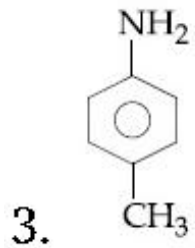
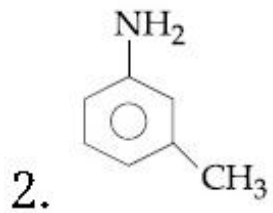
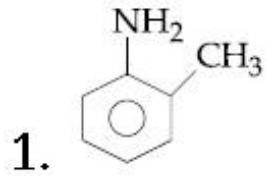

A cylinder containing an ideal gas (0.1 mol of 1.0 dm^3) is in thermal equilibrium with a large volume of 0.5 molal aqueous solution of ethylene glycol at its freezing point. If the stoppers S_1 and S_2 (as shown in the figure) are suddenly withdrawn, the volume of the gas in litres after equilibrium is achieved will be _____.

(Given, $K_f(\text{water}) = 2.0 \text{ K kg mol}^{-1}$, $R = 0.08 \text{ dm}^3 \text{ atm K}^{-1} \text{ mol}^{-1}$)

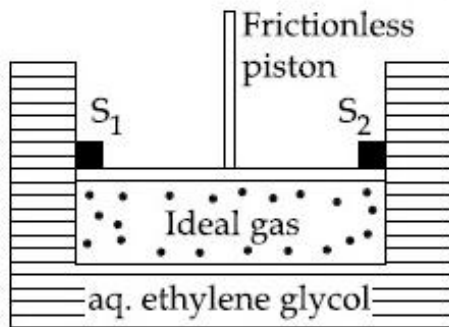

Response Type: Numeric

Evaluation Required For SA: Yes

Show Word Count: Yes

Answers Type: Range

Possible Answers :

2.17 to 2.23

Question Number : 46 Question Type : SA

Correct Marks : 4 Wrong Marks : 0

एक सिलिन्डर जिसमें एक आदर्श गैस (1.0 dm^3 का 0.1 मोल) है, हिमांक ताप पर एथिलीन ग्लाइकोल के 0.5 मोलल विलयन के साथ तापीय साम्यावस्था में है। यदि S_1 तथा S_2 स्टॉपर्स (आकृति में जिस प्रकार दर्शाया गया है) को एकाएक हटा लिया जाता है, तो साम्यावस्था प्राप्त के बाद गैस का आयतन लीटर में होगा _____।

(दिया गया है : $K_f(\text{जल}) = 2.0 \text{ K kg mol}^{-1}$, $R = 0.08 \text{ dm}^3 \text{ atm K}^{-1} \text{ mol}^{-1}$)

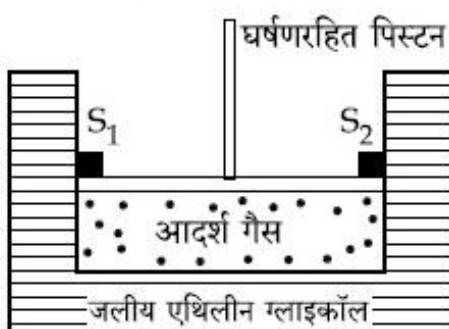

Response Type: Numeric

Evaluation Required For SA: Yes

Show Word Count: Yes

Answers Type: Range

Possible Answers :

2.17 to 2.23

Question Number : 46 Question Type : SA

Correct Marks : 4 Wrong Marks : 0

વિશાળ કદ ધરાવતા 0.5 મોલલ જલીય ઇથીલીન ગ્લાયકોલ દ્રાવણ તેના ઠારબિંદુ એ નળાકાર માં એક આદર્શ વાયુ (0.1 mol, 1.0 dm³) સાથે તેના ઊષ્મીય સંતુલન માં છે. જો સ્ટોપર S₁ અને S₂ (આકૃતિમાં દર્શાવ્યા મુજબ) અચાનક બાહી ખેંચવામાં આવે તો, સંતુલન પ્રાપ્ત કર્યા બાદ થતું વાયુ નું કદ કેટલું

આપેલ K_f (પાણી) = 2.0 K kg mol⁻¹,
R = 0.08 dm³ atm K⁻¹ mol⁻¹)

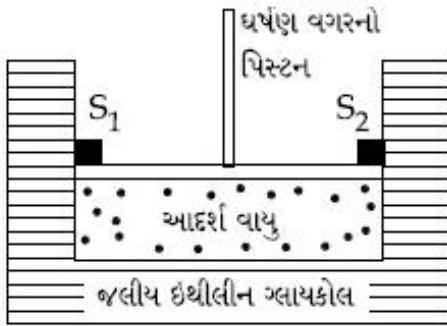

Response Type: Numeric

Evaluation Required For SA: Yes

Show Word Count: Yes

Answers Type: Range

Possible Answers :

2.17 to 2.23

Question Number : 47 Question Type : SA

Correct Marks : 4 Wrong Marks : 0

10.30 mg of O₂ is dissolved into a liter of sea water of density 1.03 g/mL. The concentration of O₂ in ppm is _____.

Response Type: Numeric

Evaluation Required For SA: Yes

Show Word Count: Yes

Answers Type: Range

Possible Answers :

10 to 0

Question Number : 47 Question Type : SA

Correct Marks : 4 Wrong Marks : 0

O₂ के 10.30 mg को 1.03 g/mL घनत्व वाले समुद्र जल के एक लीटर में घोला जाता है। O₂ की ppm में सांद्रता है _____।

Response Type: Numeric

Evaluation Required For SA: Yes

Show Word Count: Yes

Answers Type: Range

Possible Answers :

10 to 0

Question Number : 47 Question Type : SA

Correct Marks : 4 Wrong Marks : 0

10.30 mg O₂ ને એક લીટર દરિયાના પાણીના જેની ઘનતા 1.03 g/mL છે તેમાં ઓગાળવામાં આવે છે. તો O₂ ની સાંદ્રતા ppm માં શું છે _____.

Response Type: Numeric

Evaluation Required For SA: Yes

Show Word Count: Yes

Answers Type: Range

Possible Answers :

10 to 0

Question Number : 48 Question Type : SA

Correct Marks : 4 Wrong Marks : 0

A sample of milk splits after 60 min. at 300 K and after 40 min. at 400 K when the population of *lactobacillus acidophilus* in it doubles. The activation energy (in kJ/mol) for this process is closest to _____.

(Given, $R = 8.3 \text{ J mol}^{-1}\text{K}^{-1}$, $\ln\left(\frac{2}{3}\right) = 0.4$,

$e^{-3} = 4.0$)

Note: For this question, discrepancy is found in question/answer. So, this question is ignored for all candidates.

Response Type: Numeric

Evaluation Required For SA: Yes

Show Word Count: Yes

Answers Type: Range

Possible Answers :

1 to 2.01

Question Number : 48 Question Type : SA

Correct Marks : 4 Wrong Marks : 0

जब लैक्टोबैसिलस एसिडोफिलस, की आबादी दुगुनी होती है तो दूध का एक प्रतिदर्श 300 K पर 60 मिनट के बाद तथा 400 K पर 40 मिनट के बाद विपाटित होता है। इस प्रक्रम के लिए सक्रियण ऊर्जा (kJ mol^{-1} में) लगभग है _____.

(दिया गया है : $R = 8.3 \text{ J mol}^{-1}\text{K}^{-1}$,

$$\ln\left(\frac{2}{3}\right) = 0.4, e^{-3} = 4.0)$$

Note: For this question, discrepancy is found in question/answer. So, this question is ignored for all candidates.

Response Type: Numeric

Evaluation Required For SA: Yes

Show Word Count: Yes

Answers Type: Range

Possible Answers :

1 to 2.01

Question Number : 48 Question Type : SA

Correct Marks : 4 Wrong Marks : 0

દૂધનો એક નમૂનો જ્યારે લેક્ટોબેસિલસ એસિડોફિલીસ ની સાંદ્રતા (વસતી) બમણી થાય ત્યારે 300 K પર 60 મિનિટ બાદ અને 400 K એ 40 મિનિટ બાદ ફાટે છે. તો આ પ્રક્રિયા માટેની સક્રિયકરણ શક્તિ (kJ mol^{-1}) કોની નજીક હશે _____.

$$(\text{આપેલ, } R = 8.3 \text{ J mol}^{-1}\text{K}^{-1}; \ln\left(\frac{2}{3}\right) = 0.4$$

$$e^{-3} = 4.0)$$

Note: For this question, discrepancy is found in question/answer. So, this question is ignored for all candidates.

Response Type: Numeric

Evaluation Required For SA: Yes

Show Word Count: Yes

Answers Type: Range

Possible Answers :

1 to 2.01

Question Number : 49 Question Type : SA

Correct Marks : 4 Wrong Marks : 0

The sum of the total number of bonds between chromium and oxygen atoms in chromate and dichromate ions is _____.

Response Type: Numeric

Evaluation Required For SA: Yes

Show Word Count: Yes

Answers Type: Range

Possible Answers :

Question Number : 49 Question Type : SA

Correct Marks : 4 Wrong Marks : 0

क्रोमेट तथा डाइक्रोमेट में क्रोमियम तथा ऑक्सीजन के बीच आबंधों की कुल संख्याओं का योग है _____।

Response Type: Numeric

Evaluation Required For SA: Yes

Show Word Count: Yes

Answers Type: Range

Possible Answers :

12 to 12

Question Number : 49 Question Type : SA

Correct Marks : 4 Wrong Marks : 0

क्रोमेट અને ડાયક્રોમेट આયનોમાં ક્રોમિયમ અને ઓક્સિજન પરમાણુ ની વચ્ચે આવેલા બંધોની કુલ સંખ્યા નો સરવાળો શોધો _____.

Response Type: Numeric

Evaluation Required For SA: Yes

Show Word Count: Yes

Answers Type: Range

Possible Answers :

12 to 12

Question Number : 50 Question Type : SA

Correct Marks : 4 Wrong Marks : 0

Consider the following reactions

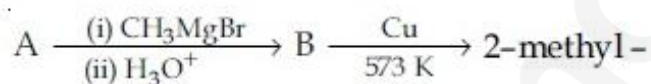

2-butene

The mass percentage of carbon in A is _____.

Response Type: Numeric

Evaluation Required For SA: Yes

Show Word Count: Yes

Answers Type: Range

Possible Answers :

66.65 to 66.70

Question Number : 50 Question Type : SA

Correct Marks : 4 Wrong Marks : 0

निम्नलिखित अभिक्रियाओं पर विचार कीजिए

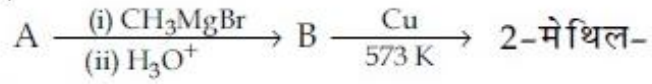

2 -ब्यूटीन

A में कार्बन की संहति प्रतिशतता है _____ ।

Response Type: Numeric

Evaluation Required For SA: Yes

Show Word Count: Yes

Answers Type: Range

Possible Answers :

66.65 to 66.70

Question Number : 50 **Question Type :** SA

Correct Marks : 4 **Wrong Marks :** 0

નીચેની પ્રક્રિયા ધ્યાનમાં લો.

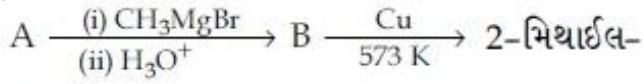

2 બ્યુટીન

A માં કાર્બનની દળ ટકાવારી શોધો _____ .

Response Type: Numeric

Evaluation Required For SA: Yes

Show Word Count: Yes

Answers Type: Range

Possible Answers :

66.65 to 66.70

Mathematics

Section Id :	40503686
Section Number :	3
Section type :	Online
Mandatory or Optional:	Mandatory
Number of Questions:	25
Number of Questions to be attempted:	25
Section Marks:	100

Sub-Section Number:	1
Sub-Section Id:	405036144
Question Shuffling Allowed :	Yes

Question Number : 51 **Question Type :** MCQ **Option Shuffling :** Yes

Correct Marks : 4 **Wrong Marks :** 1

If $A = \{x \in \mathbb{R} : |x| < 2\}$ and

$B = \{x \in \mathbb{R} : |x - 2| \geq 3\}$; then :

Options :

1. $A - B = [-1, 2)$

2. $B - A = \mathbb{R} - (-2, 5)$

3. $A \cap B = (-2, -1)$

4. $A \cup B = \mathbb{R} - (2, 5)$

Question Number : 51 Question Type : MCQ Option Shuffling : Yes
Correct Marks : 4 Wrong Marks : 1

यदि $A = \{x \in \mathbb{R} : |x| < 2\}$ तथा
 $B = \{x \in \mathbb{R} : |x - 2| \geq 3\}$, तो :

Options :

1. $A - B = [-1, 2)$

2. $B - A = \mathbb{R} - (-2, 5)$

3. $A \cap B = (-2, -1)$

4. $A \cup B = \mathbb{R} - (2, 5)$

Question Number : 51 Question Type : MCQ Option Shuffling : Yes
Correct Marks : 4 Wrong Marks : 1

જો $A = \{x \in \mathbb{R} : |x| < 2\}$ અને
 $B = \{x \in \mathbb{R} : |x - 2| \geq 3\}$ હોય, તો :

Options :

1. $A - B = [-1, 2)$

2. $B - A = R - (-2, 5)$

3. $A \cap B = (-2, -1)$

4. $A \cup B = R - (2, 5)$

Question Number : 52 Question Type : MCQ Option Shuffling : Yes
Correct Marks : 4 Wrong Marks : 1

Let $a, b \in \mathbb{R}$, $a \neq 0$ be such that the equation, $ax^2 - 2bx + 5 = 0$ has a repeated root α , which is also a root of the equation, $x^2 - 2bx - 10 = 0$. If β is the other root of this equation, then $\alpha^2 + \beta^2$ is equal to :

Options :

1. 24

2. 25

3. 26

4. 28

Question Number : 52 Question Type : MCQ Option Shuffling : Yes
Correct Marks : 4 Wrong Marks : 1

माना $a, b \in \mathbb{R}$, $a \neq 0$ इस प्रकार हैं कि समीकरण $ax^2 - 2bx + 5 = 0$ का α पुनरावृत्त मूल है, जो समीकरण $x^2 - 2bx - 10 = 0$ का भी एक मूल है। यदि β इस समीकरण का दूसरा मूल है, तो $\alpha^2 + \beta^2$ बराबर है :

Options :

1. 24

2. 25

3. 26

4. 28

Question Number : 52 Question Type : MCQ Option Shuffling : Yes
Correct Marks : 4 Wrong Marks : 1

ધારો કે $a, b \in \mathbb{R}$, $a \neq 0$ એવાં છે કે જેથી સમીકરણ
 $ax^2 - 2bx + 5 = 0$ ને પુનરાવર્તિત બીજ α હોય, કે જે
સમીકરણ $x^2 - 2bx - 10 = 0$ નું પણ એક બીજ છે.
જો β એ આ સમીકરણનું બીજું બીજ હોય, તો
 $\alpha^2 + \beta^2 = \underline{\hspace{2cm}}$.

Options :

1. 24

2. 25

3. 26

4. 28

Question Number : 53 Question Type : MCQ Option Shuffling : Yes
Correct Marks : 4 Wrong Marks : 1

If z be a complex number satisfying
 $|\operatorname{Re}(z)| + |\operatorname{Im}(z)| = 4$, then $|z|$ cannot be :

Options :

1. $\sqrt{7}$

2. $\sqrt{8}$

3. $\sqrt{10}$

4. $\sqrt{\frac{17}{2}}$

Question Number : 53 Question Type : MCQ Option Shuffling : Yes

Correct Marks : 4 Wrong Marks : 1

यदि z एक ऐसी सम्मिश्र संख्या है जो

$|\operatorname{Re}(z)| + |\operatorname{Im}(z)| = 4$ को सन्तुष्ट करती है, तो $|z|$ नहीं हो सकता :

Options :

1. $\sqrt{7}$

2. $\sqrt{8}$

3. $\sqrt{10}$

4. $\sqrt{\frac{17}{2}}$

Question Number : 53 Question Type : MCQ Option Shuffling : Yes

Correct Marks : 4 Wrong Marks : 1

જો z એ એવી સંકર સંખ્યા છે કે જે $|\operatorname{Re}(z)| + |\operatorname{Im}(z)| = 4$ નું સમાધાન કરે, તો $|z|$ નીચેનામાંથી કયું ન હોઈ શકે?

Options :

1. $\sqrt{7}$

2. $\sqrt{8}$

3. $\sqrt{10}$

4. $\sqrt{\frac{17}{2}}$

Question Number : 54 Question Type : MCQ Option Shuffling : Yes

Correct Marks : 4 Wrong Marks : 1

Let $a - 2b + c = 1$.

If $f(x) = \begin{vmatrix} x+a & x+2 & x+1 \\ x+b & x+3 & x+2 \\ x+c & x+4 & x+3 \end{vmatrix}$, then :

Options :

1. $f(50) = -501$

2. $f(-50) = 501$

3. $f(50) = 1$

4. $f(-50) = -1$

Question Number : 54 Question Type : MCQ Option Shuffling : Yes

Correct Marks : 4 Wrong Marks : 1

माना $a - 2b + c = 1$ है। यदि

$$f(x) = \begin{vmatrix} x+a & x+2 & x+1 \\ x+b & x+3 & x+2 \\ x+c & x+4 & x+3 \end{vmatrix} \text{ है, तो :}$$

Options :

1. $f(50) = -501$
2. $f(-50) = 501$
3. $f(50) = 1$
4. $f(-50) = -1$

Question Number : 54 Question Type : MCQ Option Shuffling : Yes
Correct Marks : 4 Wrong Marks : 1

ધારો કે $a - 2b + c = 1$ છે. જો

$$f(x) = \begin{vmatrix} x+a & x+2 & x+1 \\ x+b & x+3 & x+2 \\ x+c & x+4 & x+3 \end{vmatrix} \text{ હોય, તો}$$

Options :

1. $f(50) = -501$
2. $f(-50) = 501$
3. $f(50) = 1$

4. $f(-50) = -1$

Question Number : 55 Question Type : MCQ Option Shuffling : Yes
Correct Marks : 4 Wrong Marks : 1

The following system of linear equations

$$7x + 6y - 2z = 0$$

$$3x + 4y + 2z = 0$$

$$x - 2y - 6z = 0, \text{ has}$$

Options :

1. no solution.

2. only the trivial solution.

3. infinitely many solutions, (x, y, z)
satisfying $y = 2z$.

4. infinitely many solutions, (x, y, z)
satisfying $x = 2z$.

Question Number : 55 Question Type : MCQ Option Shuffling : Yes
Correct Marks : 4 Wrong Marks : 1

रैखिक समीकरणों के निम्न निकाय

$$7x + 6y - 2z = 0$$

$$3x + 4y + 2z = 0$$

$$x - 2y - 6z = 0$$

Options :

1. का कोई हल नहीं है।

2. का केवल तुच्छ हल है।

3. $y = 2z$ को सन्तुष्ट करने वाले अनन्त हल (x, y, z) हैं।

4. $x = 2z$ को सन्तुष्ट करने वाले अनन्त हल (x, y, z) हैं।

Question Number : 55 Question Type : MCQ Option Shuffling : Yes
Correct Marks : 4 Wrong Marks : 1

नीचेनी सुरेभ समीकरण संलति

$$7x + 6y - 2z = 0$$

$$3x + 4y + 2z = 0$$

$$x - 2y - 6z = 0, \text{ ने}$$

Options :

1. उकेल नथी.

2. इक्त अथोय्य (trivial) लोय तेवो न उकेल छे.

3. $y = 2z$ नुं समाधान करे तेवा अनंत उकेलो (x, y, z) छे.

4. $x = 2z$ नुं समाधान करे तेवा अनंत उकेलो (x, y, z) छे.

Question Number : 56 Question Type : MCQ Option Shuffling : Yes
Correct Marks : 4 Wrong Marks : 1

In the expansion of $\left(\frac{x}{\cos\theta} + \frac{1}{x\sin\theta}\right)^{16}$, if

l_1 is the least value of the term independent

of x when $\frac{\pi}{8} \leq \theta \leq \frac{\pi}{4}$ and l_2 is the least

value of the term independent of x when

$\frac{\pi}{16} \leq \theta \leq \frac{\pi}{8}$, then the ratio $l_2 : l_1$ is equal

to :

Options :

1. 1 : 16

2. 1 : 8

3. 16 : 1

4. 8 : 1

Question Number : 56 Question Type : MCQ Option Shuffling : Yes

Correct Marks : 4 Wrong Marks : 1

$\left(\frac{x}{\cos\theta} + \frac{1}{x\sin\theta}\right)^{16}$ के प्रसार में, यदि x से स्वतंत्र

पद का निम्नतम मान l_1 है जब $\frac{\pi}{8} \leq \theta \leq \frac{\pi}{4}$ तथा x

से स्वतंत्र पद का निम्नतम मान l_2 है जब

$\frac{\pi}{16} \leq \theta \leq \frac{\pi}{8}$, तो अनुपात $l_2 : l_1$ बराबर है :

Options :

1. 1 : 16

2. 1 : 8

3. 16 : 1

4. 8 : 1

Question Number : 56 Question Type : MCQ Option Shuffling : Yes
Correct Marks : 4 Wrong Marks : 1

જો $\left(\frac{x}{\cos\theta} + \frac{1}{x \sin\theta}\right)^{16}$ ના વિસ્તરણમાં, જ્યારે

$\frac{\pi}{8} \leq \theta \leq \frac{\pi}{4}$ હોય ત્યારે x થી સ્વતંત્ર પદની લઘુત્તમ

કિંમત l_1 અને જ્યારે $\frac{\pi}{16} \leq \theta \leq \frac{\pi}{8}$ હોય ત્યારે x થી

સ્વતંત્ર પદની લઘુત્તમ કિંમત l_2 હોય, તો ગુણોત્તર $l_2 : l_1$
= _____.

Options :

1. 1 : 16

2. 1 : 8

3. 16 : 1

4. 8 : 1

Question Number : 57 Question Type : MCQ Option Shuffling : Yes
Correct Marks : 4 Wrong Marks : 1

Let a_n be the n^{th} term of a G.P. of positive

terms. If $\sum_{n=1}^{100} a_{2n+1} = 200$ and

$\sum_{n=1}^{100} a_{2n} = 100$, then $\sum_{n=1}^{200} a_n$ is equal to :

Options :

1. 300

2. 150

3. 175

4. 225

Question Number : 57 Question Type : MCQ Option Shuffling : Yes

Correct Marks : 4 Wrong Marks : 1

माना धनात्मक पदों की एक गुणोत्तर श्रेणी का n वां

पद a_n है। यदि $\sum_{n=1}^{100} a_{2n+1} = 200$ तथा

$\sum_{n=1}^{100} a_{2n} = 100$, तो $\sum_{n=1}^{200} a_n$ बराबर है :

Options :

1. 300

2. 150

3. 175

Question Number : 57 Question Type : MCQ Option Shuffling : Yes

Correct Marks : 4 Wrong Marks : 1

ધારો કે a_n એ ધન પદોની એક સમગુણોત્તર શ્રેણી (G.P.)

નું n મું પદ છે. જો $\sum_{n=1}^{100} a_{2n+1} = 200$ અને

$$\sum_{n=1}^{100} a_{2n} = 100 \quad \text{હોય, તો} \quad \sum_{n=1}^{200} a_n$$

$$= \underline{\hspace{2cm}}.$$

Options :

1. 300

2. 150

3. 175

4. 225

Question Number : 58 Question Type : MCQ Option Shuffling : Yes

Correct Marks : 4 Wrong Marks : 1

Let $[t]$ denote the greatest integer $\leq t$ and

$$\lim_{x \rightarrow 0} x \left[\frac{4}{x} \right] = A. \quad \text{Then the function,}$$

$f(x) = [x^2] \sin(\pi x)$ is discontinuous, when x is equal to :

Options :

1. \sqrt{A}

2. $\sqrt{A+1}$

3. $\sqrt{A+5}$

4. $\sqrt{A+21}$

Question Number : 58 Question Type : MCQ Option Shuffling : Yes
Correct Marks : 4 Wrong Marks : 1

માના $[t]$ મહત્તમ પૂર્ણાંક $\leq t$ કો દર્શાતા હૈ તથા

$$\lim_{x \rightarrow 0} x \left[\frac{4}{x} \right] = A \text{ હૈ। તો ફલન } f(x) = [x^2] \sin(\pi x)$$

અસંતત હૈ, જબ x બરાબર હૈ :

Options :

1. \sqrt{A}

2. $\sqrt{A+1}$

3. $\sqrt{A+5}$

4. $\sqrt{A+21}$

Question Number : 58 Question Type : MCQ Option Shuffling : Yes
Correct Marks : 4 Wrong Marks : 1

ધારો કે $[t]$ એ મોટામાં મોટો પૂર્ણાંક $\leq t$ છે, અને

$$\lim_{x \rightarrow 0} x \left[\frac{4}{x} \right] = A \text{ છે. નીચેના પૈકી } x \text{ ની કિંમત કઈ}$$

હોય, તો વિધેય $f(x) = [x^2] \sin(\pi x)$ એ અસતત થાય?

Options :

1. \sqrt{A}

2. $\sqrt{A+1}$

3. $\sqrt{A+5}$

4. $\sqrt{A+21}$

Question Number : 59 Question Type : MCQ Option Shuffling : Yes
Correct Marks : 4 Wrong Marks : 1

If $x = 2\sin\theta - \sin 2\theta$ and $y = 2\cos\theta - \cos 2\theta$,

$\theta \in [0, 2\pi]$, then $\frac{d^2y}{dx^2}$ at $\theta = \pi$ is :

Note: For this question, discrepancy is found in question/answer. Full Marks is being awarded to all candidates.

Options :

1. $-\frac{3}{8}$

2. $-\frac{3}{4}$

3. $\frac{3}{4}$

4. $\frac{3}{2}$

Question Number : 59 Question Type : MCQ Option Shuffling : Yes
Correct Marks : 4 Wrong Marks : 1

यदि $x = 2\sin\theta - \sin 2\theta$ तथा $y = 2\cos\theta - \cos 2\theta$,

$\theta \in [0, 2\pi]$ हैं, तो $\theta = \pi$ पर $\frac{d^2y}{dx^2}$ का मान है :

Note: For this question, discrepancy is found in question/answer. Full Marks is being awarded to all candidates.

Options :

1. $-\frac{3}{8}$

2. $-\frac{3}{4}$

3. $\frac{3}{4}$

4. $\frac{3}{2}$

Question Number : 59 Question Type : MCQ Option Shuffling : Yes

Correct Marks : 4 Wrong Marks : 1

जे $x = 2\sin\theta - \sin 2\theta$ अने $y = 2\cos\theta - \cos 2\theta$,

$\theta \in [0, 2\pi]$ होय, तो $\theta = \pi$ आगत

$$\frac{d^2y}{dx^2} = \underline{\hspace{2cm}}.$$

Note: For this question, discrepancy is found in question/answer. Full Marks is being awarded to all candidates.

Options :

1. $-\frac{3}{8}$

2. $-\frac{3}{4}$

3. $\frac{3}{4}$

4. $\frac{3}{2}$

Question Number : 60 Question Type : MCQ Option Shuffling : Yes
Correct Marks : 4 Wrong Marks : 1

Let f and g be differentiable functions on \mathbb{R} such that $f \circ g$ is the identity function. If for some $a, b \in \mathbb{R}$, $g'(a) = 5$ and $g(a) = b$, then $f'(b)$ is equal to :

Options :

1. $\frac{1}{5}$

2. $\frac{2}{5}$

3. 1

4. 5

Question Number : 60 Question Type : MCQ Option Shuffling : Yes
Correct Marks : 4 Wrong Marks : 1

माना \mathbb{R} पर अवकलनीय फलन f तथा g इस प्रकार हैं कि $f \circ g$ तत्समक फलन है। यदि किसी $a, b \in \mathbb{R}$ के लिए $g'(a) = 5$ तथा $g(a) = b$ हैं, तो $f'(b)$ बराबर है :

Options :

1. $\frac{1}{5}$

2. $\frac{2}{5}$

3. 1

4. 5

Question Number : 60 Question Type : MCQ Option Shuffling : Yes
Correct Marks : 4 Wrong Marks : 1

ધારો કે f અને g એ \mathbb{R} પરનાં એવાં વિકલનીય વિધેયો છે કે જેથી $f \circ g$ એ તદ્દેવ વિધેય થાય. જો કોઈ $a, b \in \mathbb{R}$ માટે $g'(a) = 5$ અને $g(a) = b$ હોય, તો $f'(b) = \underline{\hspace{2cm}}$.

Options :

1. $\frac{1}{5}$

2. $\frac{2}{5}$

3. 1

4. 5

Question Number : 61 Question Type : MCQ Option Shuffling : Yes
Correct Marks : 4 Wrong Marks : 1

Let a function $f: [0, 5] \rightarrow \mathbb{R}$ be continuous, $f(1) = 3$ and F be defined as :

$$F(x) = \int_1^x t^2 g(t) dt, \text{ where } g(t) = \int_1^t f(u) du.$$

Then for the function F , the point $x = 1$ is :

Options :

1. not a critical point.
2. a point of local maxima.
3. a point of local minima.
4. a point of inflection.

Question Number : 61 Question Type : MCQ Option Shuffling : Yes
Correct Marks : 4 Wrong Marks : 1

माना एक फलन $f: [0, 5] \rightarrow \mathbb{R}$ संतत है, $f(1) = 3$ है

तथा F , $F(x) = \int_1^x t^2 g(t) dt$ द्वारा परिभाषित है, जहाँ

$g(t) = \int_1^t f(u) du$ है, तो फलन F के लिए, बिन्दु $x = 1$

एक :

Options :

1. क्रांतिक बिन्दु नहीं है।
2. स्थानीय उच्चिष्ठ बिन्दु है।
3. स्थानीय निम्ननिष्ठ बिन्दु है।

4. नति परिवर्तन (inflection) बिन्दु है।

Question Number : 61 Question Type : MCQ Option Shuffling : Yes

Correct Marks : 4 Wrong Marks : 1

ધારો કે વિધેય $f: [0, 5] \rightarrow \mathbb{R}$ સતત છે, $f(1) = 3$ અને

$$F(x) = \int_1^x t^2 g(t) dt, \text{ જ્યાં } g(t) = \int_1^t f(u) du \text{ દ્વારા}$$

વ્યાખ્યાયિત વિધેય F છે. તો વિધેય F માટે, બિંદુ $x = 1$ એ :

Options :

1. નિર્ણાયક બિંદુ નથી.

2. સ્થાનીય મહત્તમ માટેનું બિંદુ છે.

3. સ્થાનીય ન્યૂનતમ માટેનું બિંદુ છે.

4. નતિબિંદુ છે.

Question Number : 62 Question Type : MCQ Option Shuffling : Yes

Correct Marks : 4 Wrong Marks : 1

$$\text{If } \int \frac{d\theta}{\cos^2 \theta (\tan 2\theta + \sec 2\theta)} =$$

$\lambda \tan \theta + 2 \log_e |f(\theta)| + C$ where C is a constant of integration, then the ordered pair $(\lambda, f(\theta))$ is equal to :

Options :

1. $(-1, 1 + \tan \theta)$

2. $(1, 1 - \tan\theta)$

3. $(-1, 1 - \tan\theta)$

4. $(1, 1 + \tan\theta)$

Question Number : 62 Question Type : MCQ Option Shuffling : Yes
Correct Marks : 4 Wrong Marks : 1

यदि $\int \frac{d\theta}{\cos^2\theta(\tan 2\theta + \sec 2\theta)} =$

$\lambda \tan\theta + 2 \log_e |f(\theta)| + C$ है, जहाँ C एक समाकलन-अचर है, तो क्रमित युग्म $(\lambda, f(\theta))$ बराबर है :

Options :

1. $(-1, 1 + \tan\theta)$

2. $(1, 1 - \tan\theta)$

3. $(-1, 1 - \tan\theta)$

4. $(1, 1 + \tan\theta)$

Question Number : 62 Question Type : MCQ Option Shuffling : Yes
Correct Marks : 4 Wrong Marks : 1

जे $\int \frac{d\theta}{\cos^2\theta(\tan 2\theta + \sec 2\theta)} =$

$\lambda \tan\theta + 2 \log_e |f(\theta)| + C$. जहाँ C એ સંકલનનો અચળાંક છે, તો ક્રમયુક્ત જોડ $(\lambda, f(\theta)) =$ _____.

Options :

1. $(-1, 1 + \tan\theta)$

2. $(1, 1 - \tan\theta)$

3. $(-1, 1 - \tan\theta)$

4. $(1, 1 + \tan\theta)$

Question Number : 63 Question Type : MCQ Option Shuffling : Yes
Correct Marks : 4 Wrong Marks : 1

$$\text{Given : } f(x) = \begin{cases} x & , 0 \leq x < \frac{1}{2} \\ \frac{1}{2} & , x = \frac{1}{2} \\ 1 - x & , \frac{1}{2} < x \leq 1 \end{cases}$$

and $g(x) = \left(x - \frac{1}{2}\right)^2, x \in \mathbf{R}$. Then the area

(in sq. units) of the region bounded by the curves, $y=f(x)$ and $y=g(x)$ between the lines, $2x=1$ and $2x=\sqrt{3}$, is :

Options :

1. $\frac{1}{2} - \frac{\sqrt{3}}{4}$

2. $\frac{1}{3} + \frac{\sqrt{3}}{4}$

3. $\frac{1}{2} + \frac{\sqrt{3}}{4}$

4. $\frac{\sqrt{3}}{4} - \frac{1}{3}$

Question Number : 63 Question Type : MCQ Option Shuffling : Yes

Correct Marks : 4 Wrong Marks : 1

दिया है $f(x) = \begin{cases} x & , 0 \leq x < \frac{1}{2} \\ \frac{1}{2} & , x = \frac{1}{2} \\ 1 - x & , \frac{1}{2} < x \leq 1 \end{cases}$

तथा $g(x) = \left(x - \frac{1}{2}\right)^2, x \in \mathbb{R}$; तो रेखाओं $2x = 1$

तथा $2x = \sqrt{3}$ के बीच, वक्रों $y = f(x)$ तथा $y = g(x)$ द्वारा प्रतिबद्ध क्षेत्र का क्षेत्रफल (वर्ग इकाइयों में) है :

Options :

1. $\frac{1}{2} - \frac{\sqrt{3}}{4}$

2. $\frac{1}{3} + \frac{\sqrt{3}}{4}$

3. $\frac{1}{2} + \frac{\sqrt{3}}{4}$

4. $\frac{\sqrt{3}}{4} - \frac{1}{3}$

Question Number : 63 Question Type : MCQ Option Shuffling : Yes

Correct Marks : 4 Wrong Marks : 1

$$f(x) = \begin{cases} x & , 0 \leq x < \frac{1}{2} \\ \frac{1}{2} & , x = \frac{1}{2} \\ 1-x & , \frac{1}{2} < x \leq 1 \end{cases}$$

અને $g(x) = \left(x - \frac{1}{2}\right)^2$, $x \in \mathbb{R}$ આપેલ છે. તો

રેખાઓ $2x=1$ અને $2x = \sqrt{3}$ ની વચ્ચે, વક્રો $y=f(x)$ અને $y=g(x)$ વડે ઘેરાયેલા પ્રદેશનું ક્ષેત્રફળ (ચો.એકમમાં) કેટલું થાય?

Options :

1. $\frac{1}{2} - \frac{\sqrt{3}}{4}$

2. $\frac{1}{3} + \frac{\sqrt{3}}{4}$

3. $\frac{1}{2} + \frac{\sqrt{3}}{4}$

4. $\frac{\sqrt{3}}{4} - \frac{1}{3}$

Question Number : 64 Question Type : MCQ Option Shuffling : Yes

Correct Marks : 4 Wrong Marks : 1

If $\frac{dy}{dx} = \frac{xy}{x^2 + y^2}$; $y(1) = 1$; then a value of

x satisfying $y(x) = e$ is :

Options :

1. $\sqrt{2} e$

2. $\sqrt{3} e$

3. $\frac{1}{2}\sqrt{3} e$

4. $\frac{e}{\sqrt{2}}$

Question Number : 64 Question Type : MCQ Option Shuffling : Yes

Correct Marks : 4 Wrong Marks : 1

यदि $\frac{dy}{dx} = \frac{xy}{x^2 + y^2}$, $y(1) = 1$ है, तो $y(x) = e$

को सन्तुष्ट करने वाला x का एक मान है :

Options :

1. $\sqrt{2} e$

2. $\sqrt{3} e$

3. $\frac{1}{2}\sqrt{3} e$

4. $\frac{e}{\sqrt{2}}$

Question Number : 64 Question Type : MCQ Option Shuffling : Yes

Correct Marks : 4 Wrong Marks : 1

જો $\frac{dy}{dx} = \frac{xy}{x^2 + y^2}$, $y(1) = 1$ હોય, તો $y(x) = e$

નું સમાધાન કરતી x ની એક કિંમત _____ છે.

Options :

1. $\sqrt{2} e$

2. $\sqrt{3} e$

3. $\frac{1}{2}\sqrt{3} e$

4. $\frac{e}{\sqrt{2}}$

Question Number : 65 Question Type : MCQ Option Shuffling : Yes
Correct Marks : 4 Wrong Marks : 1

The length of the minor axis (along y -axis)

of an ellipse in the standard form is $\frac{4}{\sqrt{3}}$. If

this ellipse touches the line, $x + 6y = 8$; then
its eccentricity is :

Options :

1. $\frac{1}{3}\sqrt{\frac{11}{3}}$

2. $\frac{1}{2}\sqrt{\frac{11}{3}}$

3. $\sqrt{\frac{5}{6}}$

4. $\frac{1}{2}\sqrt{\frac{5}{3}}$

Question Number : 65 Question Type : MCQ Option Shuffling : Yes

Correct Marks : 4 Wrong Marks : 1

मानक रूप में एक दीर्घवृत्त के लघु अक्ष (y -अक्ष के अनुदिश) की लम्बाई $\frac{4}{\sqrt{3}}$ है। यदि यह दीर्घवृत्त, रेखा

$x + 6y = 8$ को स्पर्श करता है, तो इसकी उत्केन्द्रता है :

Options :

1. $\frac{1}{3} \sqrt{\frac{11}{3}}$

2. $\frac{1}{2} \sqrt{\frac{11}{3}}$

3. $\sqrt{\frac{5}{6}}$

4. $\frac{1}{2} \sqrt{\frac{5}{3}}$

Question Number : 65 Question Type : MCQ Option Shuffling : Yes

Correct Marks : 4 Wrong Marks : 1

એક પ્રમાણિત ઉપવલયની ગૌણ અક્ષ (y -અક્ષ પર) ની

લંબાઈ $\frac{4}{\sqrt{3}}$ છે. જો આ ઉપવલય, રેખા $x + 6y = 8$ ને

સ્પર્શે, તો તેની ઉત્કેન્દ્રતા _____ હોય.

Options :

1. $\frac{1}{3} \sqrt{\frac{11}{3}}$

2. $\frac{1}{2} \sqrt{\frac{11}{3}}$

3. $\sqrt{\frac{5}{6}}$

4. $\frac{1}{2} \sqrt{\frac{5}{3}}$

Question Number : 66 Question Type : MCQ Option Shuffling : Yes

Correct Marks : 4 Wrong Marks : 1

If one end of a focal chord AB of the parabola $y^2 = 8x$ is at $A\left(\frac{1}{2}, -2\right)$, then the equation of the tangent to it at B is :

Options :

1. $2x + y - 24 = 0$

2. $x + 2y + 8 = 0$

3. $x - 2y + 8 = 0$

4. $2x - y - 24 = 0$

Question Number : 66 Question Type : MCQ Option Shuffling : Yes

Correct Marks : 4 Wrong Marks : 1

यदि परवलय $y^2 = 8x$ की एक नाभि जीवा AB का एक छोर $A\left(\frac{1}{2}, -2\right)$ पर है, तो B पर इसकी स्पर्श-रेखा का समीकरण है :

Options :

1. $2x + y - 24 = 0$

2. $x + 2y + 8 = 0$

3. $x - 2y + 8 = 0$

4. $2x - y - 24 = 0$

Question Number : 66 Question Type : MCQ Option Shuffling : Yes

Correct Marks : 4 Wrong Marks : 1

જો પરવલય $y^2 = 8x$ ની નાભિ જીવા AB નું એક

અંત્યબિંદુ $A\left(\frac{1}{2}, -2\right)$ હોય, તો તેના B આગળના

સ્પર્શકનું સમીકરણ _____ છે.

Options :

1. $2x + y - 24 = 0$

2. $x + 2y + 8 = 0$

3. $x - 2y + 8 = 0$

4. $2x - y - 24 = 0$

Question Number : 67 Question Type : MCQ Option Shuffling : Yes

Correct Marks : 4 Wrong Marks : 1

A random variable X has the following probability distribution :

X :	1	2	3	4	5
$P(X)$:	K^2	$2K$	K	$2K$	$5K^2$

Then $P(X > 2)$ is equal to :

Options :

1. $\frac{1}{6}$

2. $\frac{7}{12}$

3. $\frac{23}{36}$

4. $\frac{1}{36}$

Question Number : 67 Question Type : MCQ Option Shuffling : Yes

Correct Marks : 4 Wrong Marks : 1

एक यादृच्छिक चर X का प्रायिकता बंटन निम्न है :

X :	1	2	3	4	5
$P(X)$:	K^2	$2K$	K	$2K$	$5K^2$

तो $P(X > 2)$ बराबर है :

Options :

1. $\frac{1}{6}$

2. $\frac{7}{12}$

3. $\frac{23}{36}$

4. $\frac{1}{36}$

Question Number : 67 Question Type : MCQ Option Shuffling : Yes

Correct Marks : 4 Wrong Marks : 1

એક યાદચ્છિક X ચલનું સંભાવના વિતરણ નીચે મુજબ

છે :

X :	1	2	3	4	5
$P(X)$:	K^2	$2K$	K	$2K$	$5K^2$

તો $P(X > 2) = \underline{\hspace{2cm}}$.

Options :

1. $\frac{1}{6}$

2. $\frac{7}{12}$

3. $\frac{23}{36}$

4. $\frac{1}{36}$

Question Number : 68 Question Type : MCQ Option Shuffling : Yes

Correct Marks : 4 Wrong Marks : 1

If 10 different balls are to be placed in 4 distinct boxes at random, then the probability that two of these boxes contain exactly 2 and 3 balls is :

Options :

1. $\frac{945}{2^{10}}$

2. $\frac{965}{2^{11}}$

3. $\frac{945}{2^{11}}$

4. $\frac{965}{2^{10}}$

Question Number : 68 Question Type : MCQ Option Shuffling : Yes

Correct Marks : 4 Wrong Marks : 1

यदि 10 भिन्न गेंदें, 4 भिन्न बक्सों में यादृच्छया रखी जानी हैं, तो इनमें से दो बक्सों में मात्र 2 तथा 3 गेंदों के होने की प्रायिकता है :

Options :

1. $\frac{945}{2^{10}}$

2. $\frac{965}{2^{11}}$

3. $\frac{945}{2^{11}}$

4. $\frac{965}{2^{10}}$

Question Number : 68 Question Type : MCQ Option Shuffling : Yes
Correct Marks : 4 Wrong Marks : 1

જો 10 બિત્ર દડાઓને, 4 બિત્ર ખોખાં માં યાદચ્છિક રીતે મૂકવાના હોય, તો આમાંના બે ખોખાં માં બરાબર 2 અને 3 દડા હોય તેની સંભાવના કેટલી થાય?

Options :

1. $\frac{945}{2^{10}}$

2. $\frac{965}{2^{11}}$

3. $\frac{945}{2^{11}}$

4. $\frac{965}{2^{10}}$

Question Number : 69 Question Type : MCQ Option Shuffling : Yes
Correct Marks : 4 Wrong Marks : 1

If $x = \sum_{n=0}^{\infty} (-1)^n \tan^{2n} \theta$ and $y = \sum_{n=0}^{\infty} \cos^{2n} \theta$,

for $0 < \theta < \frac{\pi}{4}$, then :

Options :

1. $y(1+x) = 1$

2. $y(1-x)=1$

3. $x(1-y)=1$

4. $x(1+y)=1$

Question Number : 69 Question Type : MCQ Option Shuffling : Yes

Correct Marks : 4 Wrong Marks : 1

यदि $0 < \theta < \frac{\pi}{4}$ के लिए, $x = \sum_{n=0}^{\infty} (-1)^n \tan^{2n} \theta$

तथा $y = \sum_{n=0}^{\infty} \cos^{2n} \theta$ हैं, तो :

Options :

1. $y(1+x)=1$

2. $y(1-x)=1$

3. $x(1-y)=1$

4. $x(1+y)=1$

Question Number : 69 Question Type : MCQ Option Shuffling : Yes

Correct Marks : 4 Wrong Marks : 1

यदि $0 < \theta < \frac{\pi}{4}$ मध्ये $x = \sum_{n=0}^{\infty} (-1)^n \tan^{2n} \theta$ असे

$y = \sum_{n=0}^{\infty} \cos^{2n} \theta$ होय, तब :

Options :

1. $y(1+x)=1$

2. $y(1-x)=1$

3. $x(1-y)=1$

4. $x(1+y)=1$

Question Number : 70 Question Type : MCQ Option Shuffling : Yes

Correct Marks : 4 Wrong Marks : 1

If $p \rightarrow (p \wedge \sim q)$ is false, then the truth values of p and q are respectively :

Options :

1. F, F

2. T, F

3. F, T

4. T, T

Question Number : 70 Question Type : MCQ Option Shuffling : Yes

Correct Marks : 4 Wrong Marks : 1

यदि $p \rightarrow (p \wedge \sim q)$ असत्य है, तो p तथा q के क्रमशः सत्यमान हैं :

Options :

1. F, F

2. T, F

3. F, T

4. T, T

Question Number : 70 Question Type : MCQ Option Shuffling : Yes
Correct Marks : 4 Wrong Marks : 1

જો $p \rightarrow (p \wedge \sim q)$ અસત્ય હોય, તો p અને q ની
સત્યાર્થતા મૂલ્યો અનુક્રમે _____ છે.

Options :

1. F, F

2. T, F

3. F, T

4. T, T

Sub-Section Number: 2
Sub-Section Id: 405036145
Question Shuffling Allowed : Yes

Question Number : 71 Question Type : SA
Correct Marks : 4 Wrong Marks : 0

If $C_r \equiv {}^{25}C_r$ and

$C_0 + 5 \cdot C_1 + 9 \cdot C_2 + \dots + (101) \cdot C_{25} = 2^{25} \cdot k,$
then k is equal to _____.

Response Type: Numeric

Evaluation Required For SA: Yes

Show Word Count: Yes

Answers Type: Range

Possible Answers :

51 to 51

Question Number : 71 Question Type : SA

Correct Marks : 4 Wrong Marks : 0

यदि $C_r \equiv {}^{25}C_r$ तथा

$C_0 + 5 \cdot C_1 + 9 \cdot C_2 + \dots + (101) \cdot C_{25} = 2^{25} \cdot k$, तो
k बराबर है _____।

Response Type: Numeric

Evaluation Required For SA: Yes

Show Word Count: Yes

Answers Type: Range

Possible Answers :

51 to 51

Question Number : 71 Question Type : SA

Correct Marks : 4 Wrong Marks : 0

જો $C_r \equiv {}^{25}C_r$ અને

$C_0 + 5 \cdot C_1 + 9 \cdot C_2 + \dots + (101) \cdot C_{25} = 2^{25} \cdot k$
હોય, તો $k =$ _____.

Response Type: Numeric

Evaluation Required For SA: Yes

Show Word Count: Yes

Answers Type: Range

Possible Answers :

51 to 51

Question Number : 72 Question Type : SA

Correct Marks : 4 Wrong Marks : 0

The number of terms common to the two
A.P.'s 3, 7, 11,, 407 and 2, 9, 16,, 709 is

_____.

Response Type: Numeric

Evaluation Required For SA: Yes

Show Word Count: Yes

Answers Type: Range

Possible Answers :

14 to 14

Question Number : 72 Question Type : SA

Correct Marks : 4 Wrong Marks : 0

दो समांतर श्रेणियों 3, 7, 11,, 407 तथा 2, 9, 16,
....., 709 में उभयनिष्ठ (common) पदों की संख्या है

_____।

Response Type: Numeric

Evaluation Required For SA: Yes

Show Word Count: Yes

Answers Type: Range

Possible Answers :

14 to 14

Question Number : 72 Question Type : SA

Correct Marks : 4 Wrong Marks : 0

બે સમાંતર શ્રેણીઓ (A.P.'s) 3, 7, 11,, 407 અને 2, 9, 16,, 709 માં સામાન્ય પદોની સંખ્યા _____ છે.

Response Type: Numeric

Evaluation Required For SA: Yes

Show Word Count: Yes

Answers Type: Range

Possible Answers :

14 to 14

Question Number : 73 Question Type : SA

Correct Marks : 4 Wrong Marks : 0

If the curves, $x^2 - 6x + y^2 + 8 = 0$ and $x^2 - 8y + y^2 + 16 - k = 0$, ($k > 0$) touch each other at a point, then the largest value of k is _____.

Response Type: Numeric

Evaluation Required For SA: Yes

Show Word Count: Yes

Answers Type: Range

Possible Answers :

36 to 36

Question Number : 73 Question Type : SA

Correct Marks : 4 Wrong Marks : 0

यदि वक्र $x^2 - 6x + y^2 + 8 = 0$ तथा $x^2 - 8y + y^2 + 16 - k = 0$, ($k > 0$) एक दूसरे को एक बिन्दु पर स्पर्श करते हैं, तो k का अधिकतम मान है _____ ।

Response Type: Numeric

Evaluation Required For SA: Yes

Show Word Count: Yes

Answers Type: Range

Possible Answers :

36 to 36

Question Number : 73 Question Type : SA

Correct Marks : 4 Wrong Marks : 0

જો વક્રો $x^2 - 6x + y^2 + 8 = 0$ અને $x^2 - 8y + y^2 + 16 - k = 0$ ($k > 0$) પરસ્પર એક બિંદુએ સ્પર્શે તો k ની મહત્તમ કિંમત _____ છે.

Response Type: Numeric

Evaluation Required For SA: Yes

Show Word Count: Yes

Answers Type: Range

Possible Answers :

36 to 36

Question Number : 74 Question Type : SA

Correct Marks : 4 Wrong Marks : 0

If the distance between the plane, $23x - 10y - 2z + 48 = 0$ and the plane containing the lines

$$\frac{x+1}{2} = \frac{y-3}{4} = \frac{z+1}{3}$$

$$\text{and } \frac{x+3}{2} = \frac{y+2}{6} = \frac{z-1}{\lambda} \quad (\lambda \in \mathbb{R})$$

is equal to $\frac{k}{\sqrt{633}}$, then k is equal to

_____.

Response Type: Numeric

Evaluation Required For SA: Yes

Show Word Count: Yes

Answers Type: Range

Possible Answers :

3 to 3

Question Number : 74 Question Type : SA

Correct Marks : 4 Wrong Marks : 0

यदि समतल $23x - 10y - 2z + 48 = 0$ तथा रेखाओं

$$\frac{x+1}{2} = \frac{y-3}{4} = \frac{z+1}{3}$$

$$\text{और } \frac{x+3}{2} = \frac{y+2}{6} = \frac{z-1}{\lambda} \quad (\lambda \in \mathbb{R})$$

को अंतर्विष्ट करने वाले समतल के बीच की दूरी $\frac{k}{\sqrt{633}}$

है, तो k बराबर है _____।

Response Type: Numeric

Evaluation Required For SA: Yes

Show Word Count: Yes

Answers Type: Range

Possible Answers :

3 to 3

Question Number : 74 Question Type : SA

Correct Marks : 4 Wrong Marks : 0

જો સમતલ $23x - 10y - 2z + 48 = 0$ અને રેખાઓ

$$\frac{x+1}{2} = \frac{y-3}{4} = \frac{z+1}{3}$$

તથા $\frac{x+3}{2} = \frac{y+2}{6} = \frac{z-1}{\lambda}$ ($\lambda \in \mathbf{R}$) ને

સમાપતા સમતલ વચ્ચેનું અંતર $\frac{k}{\sqrt{633}}$ હોય, તો $k =$

_____.

Response Type: Numeric

Evaluation Required For SA: Yes

Show Word Count: Yes

Answers Type: Range

Possible Answers :

3 to 3

Question Number : 75 **Question Type :** SA

Correct Marks : 4 **Wrong Marks :** 0

Let \vec{a} , \vec{b} and \vec{c} be three vectors such that

$|\vec{a}| = \sqrt{3}$, $|\vec{b}| = 5$, $\vec{b} \cdot \vec{c} = 10$ and the angle between \vec{b} and \vec{c} is $\frac{\pi}{3}$. If \vec{a} is

perpendicular to the vector $\vec{b} \times \vec{c}$, then

$|\vec{a} \times (\vec{b} \times \vec{c})|$ is equal to _____.

Response Type: Numeric

Evaluation Required For SA: Yes

Show Word Count: Yes

Answers Type: Range

Possible Answers :

30 to 30

Question Number : 75 **Question Type :** SA

Correct Marks : 4 **Wrong Marks :** 0

माना तीन सदिश \vec{a} , \vec{b} तथा \vec{c} इस प्रकार हैं कि

$|\vec{a}| = \sqrt{3}$, $|\vec{b}| = 5$, $\vec{b} \cdot \vec{c} = 10$ तथा

\vec{b} और \vec{c} के बीच का कोण $\frac{\pi}{3}$ है। यदि \vec{a} , सदिश

$\vec{b} \times \vec{c}$ पर लम्बवत है, तो $|\vec{a} \times (\vec{b} \times \vec{c})|$ बराबर है _____ ।

Response Type: Numeric

Evaluation Required For SA: Yes

Show Word Count: Yes

Answers Type: Range

Possible Answers :

30 to 30

Question Number : 75 Question Type : SA

Correct Marks : 4 Wrong Marks : 0

ધારો કે \vec{a} , \vec{b} અને \vec{c} એ એવા ત્રણ સદિશો છે કે

જેથી $|\vec{a}| = \sqrt{3}$, $|\vec{b}| = 5$, $\vec{b} \cdot \vec{c} = 10$ તથા

\vec{b} અને \vec{c} વચ્ચેનો ખૂણો $\frac{\pi}{3}$ છે. જો \vec{a} એ

$\vec{b} \times \vec{c}$ ને લંબ હોય, તો $|\vec{a} \times (\vec{b} \times \vec{c})| =$

_____.

Response Type: Numeric

Evaluation Required For SA: Yes

Show Word Count: Yes

Answers Type: Range

Possible Answers :

30 to 30

