

NG 22 (GROUP A)

PART I — ENGINEERING MATHEMATICS

(Common to all candidates)

(Answer ALL questions)

1. The eigenvalues of the matrix $\begin{pmatrix} 1 & 1 & 3 \\ 1 & 5 & 1 \\ 3 & 1 & 1 \end{pmatrix}$ are
- 2, -3, 6
 - 2, 3, 6
 - 2, -3, -6
 - 2, 3, 6
2. For what value of k , the matrix $A = \begin{bmatrix} 2 & k \\ 3 & 5 \end{bmatrix}$ has no inverse?
- 3
 - 10/3
 - 2
 - 10/3
3. The index and signature of the quadratic form $x_1^2 + 2x_2^2 - 3x_3^2$ are
- Index = 2 ; Signature = -1
 - Index = 2 ; Signature = 1
 - Index = 1 ; Signature = 2
 - Index = 1 ; Signature = -2
4. If $u = x^2 + y^2$ then $\frac{\partial^2 u}{\partial x \partial y}$ is equal to
- 2
 - 0
 - 2xy
 - 2(x + y)
5. If $x = u(1 - v)$ and $y = uv$ then the Jacobian $J\left(\frac{u, v}{x, y}\right)$ is
- $x + y$
 - $\frac{1}{x + y}$
 - 1
 - xy
6. The Taylor's expansion of the function $f(x) = \frac{1}{1 + x^2}$ is
- $\sum_{n=0}^{\infty} (-1)^n x^{2n}$ for $-1 < x < 1$
 - $\sum_{n=0}^{\infty} x^{2n}$ for $-1 < x < 1$
 - $\sum_{n=0}^{\infty} (-1)^n x^n$ for $-1 < x < 1$
 - $\sum_{n=0}^{\infty} (-1)^n x^{2n}$ for any real x
7. If $\vec{F} = x^2 yz \hat{i} + xy^2 z \hat{j} + xyz^2 \hat{k}$ then $\text{div } \vec{F}$ at (1, 2, 3) is
- 1
 - 6
 - 12
 - 24

8. The work done in moving a particle by the force $\vec{F} = (5xy - 6x^2)\hat{i} + (2y - 4x)\hat{j}$ from (1, 1) to (2, 8) along $y = x^3$ is

- a. 24
- b. 35
- c. 48
- d. 70

9. The value of $\oint_{|z|=1} \frac{z^2}{(2z-1)^2} dz$ is

- a. $2\pi i$
- b. πi
- c. $\pi i/2$
- d. $4\pi i$

10. The fixed points of the mapping $w = \frac{5z+4}{z+5}$ are

- a. 2, 2
- b. 2, -2
- c. -2, -2
- d. -4/5, 5

11. The residue of $f(z) = \frac{z^2}{(z-1)^2(z+2)}$ at $z = 1$ is

- a. 4/9
- b. 5/9
- c. 1/3
- d. 1/9

12. The inverse Laplace transform of $\frac{-1}{(s+a)^2}$ is

- a. e^{at}
- b. e^{-at}
- c. te^{-at}
- d. te^{at}

13. Using Parseval's identity of Fourier

transform, the value of $\int_0^\infty \frac{dt}{(a^2+t^2)(b^2+t^2)}$ is

- a. $\frac{\pi}{a+b}$
- b. $\frac{\pi}{ab(a+b)}$
- c. $\frac{\pi}{2ab(a+b)}$
- d. $\frac{\pi}{2(a+b)}$

14. The Z transform of $\frac{1}{(n+1)!}$ is

- a. $e^{1/z}$
- b. $ze^{1/z}$
- c. $ze^{1/z} - 1$
- d. $z(e^{1/z} - 1)$

15. The approximate value of the roots of the equation $x^3 + x - 1 = 0$ lying in the interval $(0, 1)$ using the method of false position with two iteration is given by

- a. 0.61
- b. 0.72
- c. 0.74
- d. 0.64

18. Given that E and F are events such that $P(E) = 0.6$, $P(F) = 0.3$ and $P(E \cap F) = 0.2$, the value of $P(E / F)$ is

- a. $2/3$
- b. $1/3$
- c. $1/2$
- d. $1/5$

16. The fourth divided difference of the polynomial $3x^3 + 11x^2 + 5x + 11$ over the points $x = 0, 1, 4, 6, 7$ is

- a. 18
- b. 11
- c. 3
- d. 0

19. If X has uniform distribution in $(-1, 3)$ and Y has exponential distribution with parameter λ , then the value of λ such that $Var(X) = Var(Y)$ is

- a. $4/3$
- b. $3/4$
- c. $\frac{2}{\sqrt{3}}$
- d. $\frac{\sqrt{3}}{2}$

17. Simpson's rule for evaluation of $\int_a^b f(x) dx$ requires the interval (a, b) to be divided into

- a. $3n$ intervals
- b. $(2n + 1)$ intervals
- c. $2n$ intervals
- d. $(3n + 1)$ intervals

20. If the correlation coefficient is zero then the two lines of regression are

- a. parallel
- b. perpendicular
- c. coincident
- d. inclined at 45° to each other

PART II — BASIC ENGINEERING AND SCIENCES

(Common to all candidates)

(All correct answers upto a maximum number of 20 will be given credit, but all wrong answers will be taken into account for negative marking)

21. _____ law defines the absolute zero of entropy

- a. Zeroth law
- b. First law
- c. Second law
- d. Third law

22. Streamline, pathline and streakline are identical when the flow is

- a. steady
- b. uniform
- c. unsteady
- d. neither steady nor uniform

23. _____ relates to the United Nations Framework Convention on Climate Change by committing industrialized countries and economies to limit and reduce greenhouse gases (GHG) emissions.

- a. Montreal protocol
- b. Nagoya protocol
- c. Kyoto protocol
- d. Cartagena protocol

24. When the length of the conductor is doubled and the area of cross-section remains the same then its resistivity

- a. Remains the same
- b. Will be doubled
- c. Will become half
- d. Will increase by four times

25. The variables which can be accessed by all modules in a program are called

- a. external variables
- b. local variables
- c. internal variables
- d. global variables

26. How many memory locations would be reserved for the following program?

```
main()
{
    int i[10];
    char c[10];
    long l[10];
}
```

- a. 90
- b. 30
- c. 70
- d. 50

27. Find the output of the C code.

```
#include <stdio.h>
int main()
{
    const int ary[4] = {1, 2, 3, 4};
    int *p;
    p = ary + 3;
    *p = 5;
    printf("%d\n", ary[3]);
}
```

- a. 4
- b. 5
- c. Compile time error
- d. 3

28. Find the output of the C code.

```
#include <stdio.h>
void main()
{
    int h = 8;
    int b = h++ + h++ + h++;
    printf("%d\n", h);
}
```

- a. 9
- b. 10
- c. 12
- d. 11

29. The reason for the implementation of the cache memory is
- To increase the internal memory of the system
 - The difference in speeds of operation of the processor and memory
 - To reduce the memory access and cycle time
 - All of the above
30. The contents of the EPROM are erased by
- Overcharging the chip
 - Exposing the chip to UV rays
 - Exposing the chip to IR rays
 - Discharging the Chip
31. A coal containing high amount of volatile matter will have
- Very little ash content
 - Low ignition temperature
 - High fusion point of its ash
 - Low adiabatic flame temperature
32. Consider a reaction $aC + bD \rightarrow \text{Products}$. When the concentration of both the reactants C and D is doubled, the rate increases eight times. However, when the concentration of C is doubled, keeping the concentration of D fixed, the rate is doubled. The overall order of the reaction is
- 0
 - 1
 - 2
 - 3
33. 10800 C of electricity passed through the electrolyte deposited 2.977 g of metal with atomic mass 106.4 g mol^{-1} . The charge on the metal cation is
- +4
 - +3
 - +2
 - +1
34. Two sounds differ in sound level by 1.00 dB. The ratio of the greater intensity to the smaller intensity is
- 10
 - 100
 - $10^{0.1}$
 - $10^{0.01}$
35. The maximum spectral radiance for a black body at 2000 K lies in the infrared region. _____ in the _____ of that black body shifts the maximum into the visible range.
- An increase, temperature
 - Decrease, temperature
 - An increase, pressure
 - Decrease, pressure
36. Lasers used in CD and DVD players are
- He-Ne laser
 - CO_2 laser
 - Semiconductor lasers
 - Dye lasers
37. A typical relative refractive index difference between the core and the cladding of an optical fiber designed for long distance transmission is 1%. The numerical aperture for the fiber when the core index is equal to 1.46 is
- 0.21
 - 0.15
 - 0.10
 - 0.03
38. The coordination number and the atomic packing factor for the HCP structure are
- 8 and 0.68, respectively
 - 8 and 0.74, respectively
 - 12 and 0.68, respectively
 - 12 and 0.74, respectively

39. The ductile and brittle fractures occur because of
- crack propagation only
 - plastic deformation only
 - plastic deformation and crack propagation, respectively
 - crack propagation and plastic deformation, respectively

40. In a ferromagnetic material, susceptibility is
- very large and negative
 - very large and positive
 - zero
 - negative

41. Fermi level for extrinsic semiconductor depends on
- Donor element
 - Impurity concentration
 - Temperature
 - All of the above

42. Three forces A, B, and C of magnitude 8 N, 12 N and 20 N acting on a particle are in equilibrium. It can be concluded that
- A and B act at 90°
 - One of the forces is non-coplanar
 - B and C act in opposite directions
 - One of the forces is non-concurrent

43. Polar moment of inertia of given rectangular area is

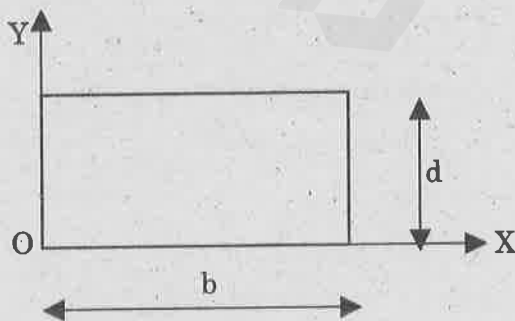

- $(bd^3 + db^3) / 12$
- $(bd^3 + db^3) / 3$
- $bd^3/12$
- $db^3 / 12$

44. The extraction of a nail is greatly facilitated by a block placed under the head of a claw hammer. Consider a 200 N pull on the handle, which is required to pull the nail. Calculate the tension in the nail.

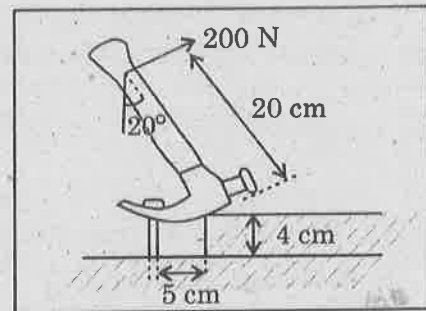

- 800 N
- 200 N
- 400 N
- 1000 N

45. Consider a particle moving along 1 dimension (X coordinate) with an acceleration $a(t) = 3t^2 + 5t + 1$ m/s², where "t" is time in seconds. At $t = 0$, velocity (v) = 4 m/s. What is the velocity (v) in m/s at $t = 3$ s?

- 5.65 m/s
- 65.5 m/s
- 56.5 m/s
- 6.55 m/s

46. The weight of two children sitting at ends A and B of a seesaw are 420 N and 320 N respectively. Where should a third child sit so that the resultant of the weights of the three children will pass through C if she weighs 300 N?

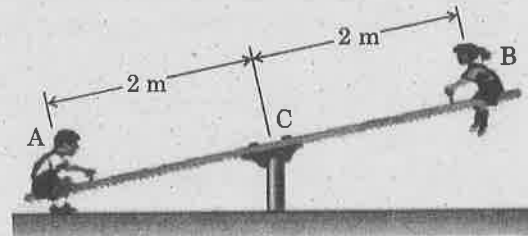

- 0.5 m
- 1 m
- 1.5 m
- 0.667 m

47. The ideal gas is characterized by
- finite intermolecular forces and molecules are made of point masses.
 - negligible intermolecular forces and molecules are made of point masses.
 - finite intermolecular distances and molecules are made of point masses.
 - finite intermolecular forces and molecules are made of infinitesimal masses.
48. While pressurising the air in a cycle pump, 100 kJ of work is supplied and 20 kJ of heat is rejected, the change in internal energy is
- 120 kJ
 - +120 kJ
 - 80 kJ
 - +80 kJ
49. Thermal equilibrium of a system is analysed based on the
- first law of thermodynamics
 - second law of thermodynamics
 - third law of thermodynamics
 - zeroth law of thermodynamics
50. An ideal engine operates between 327 deg.C and 27 deg.C. If the engine produces, 300 kJ of work, the heat rejected by the engine is
- 0 kJ
 - 100 kJ
 - 200 kJ
 - 300 kJ
51. SCR (Short Circuit Ratio) of a synchronous machine is defined as:
- $\frac{1}{X_s(\text{Unsaturated})}$
 - $\frac{1}{X_s(\text{Unsaturated})(\text{per unit})}$
 - $\frac{1}{X_s(\text{saturated})(\text{per unit})}$
 - $\frac{1}{X_s(\text{saturated})}$
52. In a cylindrical rotor synchronous machine, the phasor summation of stator MMF and rotor MMF is possible because:
- The two MMF are rotating in opposite directions
 - Two MMF are rotating in same direction
 - One MMF is stationary and the other is rotating
 - Two MMF are stationary with respect to each other
53. A 250V, DC shunt motor having armature and field resistances of 0.05Ω and 50Ω , respectively, delivers 17.5kW output while drawing 20kW as input. What will be its armature copper loss when maximum efficiency is obtained?
- 2219 W
 - 2500 W
 - 2469 W
 - 2782 W
54. The number of parallel paths in lap-wound armature are
- Equal to the number of poles of the machine
 - Equal to two, irrespective of the number of poles
 - Equal to the number of commutator segments
 - Equal to the number of armature conductors
55. When the machine operates as a generator at load, the relation between induced EMF and terminal voltage is:
- $E_g > V$
 - $E_g < V$
 - $E_b = V$
 - $E_b = 1$

PART III

01— CIVIL ENGINEERING

(Answer ALL questions)

56. The ratio of elongations of a conical bar due to its own weight and that of a prismatic bar of the same length, is

- a. 1/2
- b. 1/3
- c. 1/4
- d. 1/5

57. The total elongation produced in a bar of uniform section hanging vertically downwards due to its own weight is equal to that produced by a weight

- a. Of same magnitude as that of bar and applied at the lower end
- b. Half the weight of bar applied at lower end
- c. Half of the square of weight of bar applied at lower end
- d. One fourth of weight of bar applied at lower end

58. For a simply supported beam of length L , the bending moment M is described as $M = a(x - x^3/L^2)$, $0 \leq x < L$; where a is a constant. The shear force will be zero at

- a. the supports
- b. $x = L/2$
- c. $x = L/3$
- d. $x = L/4$

59. Two closely coiled helical springs 'A' and 'B' are equal in all respects but the number of turns of spring 'A' is half that of spring 'B'. The ratio of deflections in spring 'A' to spring 'B' is

- a. 1/8
- b. 1/4
- c. 1/2
- d. 2

60. Two shafts 'A' and 'B' are made of same material. The shaft 'A' is solid and has diameter D . The shaft 'B' is hollow with outer diameter D and inner diameter $D/2$. The strength of hollow shaft in torsion is _____ as that of solid shaft.

- a. 1/16
- b. 1/8
- c. 1/4
- d. 15/16

61. The vertical reaction at the support A for the frame shown in the figure is

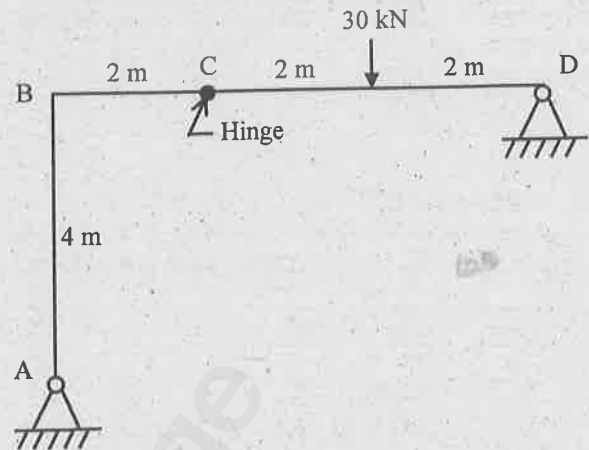

- a. 20 kN
- b. 10 kN
- c. 15 kN
- d. 5 kN

62. Naylor's simplification for moment distribution is applicable for

- a. symmetrical frame with symmetrical loading
- b. unsymmetrical frame with symmetrical loading
- c. symmetrical frame with anti-symmetrical loading
- d. any frame with anti - symmetrical loading

63. The influence line diagram for bending moment at any section in a propped cantilever has both positive and negative portions when the distance of the section from the propped end is

- a. less than two - third of the span
- b. equal to two - third of the span
- c. greater than two - third of the span
- d. equal to one - fourth of the span.

64. Match List - I with List - II and select the correct answer using the code given below the Lists :

List - I		List - II	
A. Axel Bendixen	1. Force method		
B. Hardy Cross	2. Influence line		
C. Winkler	3. Slope Deflection Method		
D. Muller Breslau	4. Moment Distribution		

Code :

	A	B	C	D
a.	1	4	2	3
b.	3	4	2	1
c.	1	2	4	3
d.	3	2	4	1

65. The shape factor for a circular section in plastic design of steel structure is

- $\frac{16}{3\pi}$
- $\frac{8}{3\pi}$
- $\frac{32}{3\pi}$
- $\frac{3\pi}{16}$

66. In Metamorphic rocks, the limestone is changed in to

- Quartzite
- Shale
- Slate
- Marble

67. These bricks are made from olivine rock to which magnesia is added in the manufacturing process. This bricks are called as

- Acid resistance bricks
- Fire clay bricks
- Forsterite bricks
- Silicon carbide bricks

68. The soundness test of cement is an indication of excess of this material caused by inadequate burning of cement or excess of magnesia or sulphates.

- Iron oxide
- Lime
- Alumina
- Aluminium

69. Glued and laminated wood is called as

- Laminates
- Spirals
- Laminboards
- Glulam

70. The process of cutting and sawing logs into suitable section of timber is known as

- Conversion
- Thickening
- Thinning
- Clotting

71. The camber of beams with straight tendons is given by

- $(PeL^2)/(8EI)$
- $(Pe^2L)/(8EI)$
- $(PeL^2)/(6EI)$
- $(Pe^2L)/(6EI)$

72. The loss of prestress in steel due to creep of concrete is given by _____ where creep coefficient ϕ is 0.6, stress in concrete at the level of steel is 10.2 N/mm^2 , Young's modulus of steel and concrete are 210 kN/mm^2 and 35 N/mm^2 respectively.

- 38.25 N/mm^2
- 2.72 N/mm^2
- 97.92 N/mm^2
- 0.941 N/mm^2

73. The working stress method of design specifies the value of modular ratio $m = 280/3\sigma_{cbc}$, where σ_{cbc} is the allowable stress in bending compression in concrete. To what extent does the above value of 'm' make any allowance for the creep of concrete?

- No compensation
- Full compensation
- Partial Compensation
- The two are unrelated

74. In the limit state design method of concrete structures, the recommended partial material safety factor (γ_m) for steel according to IS:456-2000 is
- 1.5
 - 1.15
 - 1.00
 - 0.87
75. The effective width of a reinforced concrete T-beam flange under compression, according to IS:456 - 2000, given ' I_0 ' is the distance between the adjacent zero moment points, ' b ' is the breadth of the rib and ' D ' is the thickness of the flange, is
- $(I_0/6) + b + 6D$
 - $(I_0) + 6D$
 - $(I_0/6) + 6D$
 - $(I_0/6) + b$
76. IS800-2007 suggests that purlins be designed as
- cantilever beams
 - continuous beams
 - simply supported beams
 - fixed beams
77. Mode of failure of fillet weld is
- tension
 - bearing
 - bending
 - shear
78. The slenderness ratio of lacing should not exceed
- 125
 - 145
 - 165
 - 185
79. For rolled angle section the curve used for major axis buckling is
- curve A
 - curve B
 - curve C
 - curve D
80. As per IS800-2007, the maximum slenderness ratio for members under tension (other than pre-tensioned members) is
- 200
 - 300
 - 400
 - 500
81. In consolidated drained test on a saturated soil sample, pore water pressure is zero during.
- Consolidation stage only
 - Shearing stage only
 - Both consolidation and shearing stages
 - Loading stage
82. In a soil specimen, 70% of particles are passing through 4.75 mm I.S sieve and 40% of particles are passing through 75 μ I.S. sieve. Its uniformity coefficient is 8 and coefficient of curvature is 2. As per I.S. classification, this soil is classified as
- SP
 - GP
 - SW
 - GW
83. Match List I (Roller type) with List II (soil type) and select the correct answer :
- | List - I | List - II |
|--------------------------|---------------------------------------|
| A. Pneumatic roller | 1. Cohesive and granular soils |
| B. Smooth wheeled Roller | 2. Plastic soils of moderate cohesion |
| C. Sheep foot roller | 3. Cohesionless soils |
| D. Vibratory roller | 4. Silty soils of low plasticity |
- Code :
- | | A | B | C | D |
|----|---|---|---|---|
| a. | 4 | 2 | 1 | 3 |
| b. | 3 | 1 | 2 | 4 |
| c. | 4 | 1 | 2 | 3 |
| d. | 3 | 2 | 1 | 4 |

84. Consider the following statements :

- I. Effective stress in a sand layer below a lake with standing water does not alter as the water level fluctuates.
- II. Regarding water table below the ground surface, any rise in the water table causes equal changes in both pore pressure and effective stress.
- III. Capillary saturation will cause the effective stress to increase.

Which of the above statements are correct?

- a. I, II and III
- b. I and II only
- c. II and III only
- d. I and III only

85. A Soil yielded a maximum dry unit weight of 18 kN/m^3 at a moisture content of 16% during a Standard Proctor Test. What is the degree of saturation of the soil if its specific gravity is 2.65?

- a. 98.42%
- b. 95.50%
- c. 84.32%
- d. 75.71%

86. As per Terzaghi's equation, the bearing capacity of strip footing resting on cohesive soil ($c = 10 \text{ kN/m}^2$) for unit depth and unit width (assume N_c as 5.7) is

- a. 47 kN/m^2
- b. 57 kN/m^2
- c. 67 kN/m^2
- d. 77 kN/m^2

87. Consider the following statements:

1. Standard penetration test (SPT) is conducted by pushing a cone into soil at the rate of 2 cm/s.
2. Standard penetration test results are unreliable in deposits containing large number of boulders.
3. Dutch cone is a static penetrometer.

Which of the above statements is/are correct?

- a. 1 only
- b. 1 and 2
- c. 2 and 3
- d. 3 only

88. A drop hammer is used to drive a wooden pile. The hammer weight is 25 kN and its free falling height is 0.8 m. the penetration in the last blow is 12 mm. what is the nearest approximation to the load carrying capacity of the pile according to the Engineering News Formula?

- a. 125 kN
- b. 110 kN
- c. 3000 kN
- d. 90 kN

89. Consider the following statements :

- I. The soil obtained from wash boring is a representative sample.
- II. Recovery ratio will be high during drilling in sound rock.
- III. Hollow stem augers are sometimes used to drill holes in silty sand.

Which of the above statements is/are correct?

- a. I only
- b. I and II
- c. II and III
- d. III only

90. What is the intensity of active earth pressure at a depth of 10.0 m in dry sand with an angle of shearing resistance of 30° and unit weight of 18 kN/m^3 ?

- a. 50 kN/m^2
- b. 60 kN/m^2
- c. 70 kN/m^2
- d. 80 kN/m^2

91. The traffic design in India is based on

- a. 10th hourly volume
- b. 20th hourly volume
- c. 30th hourly volume
- d. 45th hourly volume

92. If space mean speed of a vehicle is 50 kmph, then the time mean speed will be

- a. Less than 50kmph
- b. Greater than 50kmph
- c. Equal to 50kmph
- d. Depends on the vehicle

93. The spacing between longitudinal joints may be.
- 3.0 m
 - 3.2 m
 - 3.5 m
 - 4.0 m
94. The side slope of embankments for a railway track is generally taken as
- 1:1
 - 1.5:1
 - 1:2
 - 2:1
95. A low wall built out into the sea more or less perpendicular to the coast line, to resist the travel of sand and shingle along a beach, is called
- Break Water
 - Groins
 - Break Wall
 - Shore Wall
96. A 100 year peak discharge means
- A maximum discharge which occurs in 101 years
 - A maximum discharge of 100 year recurrence interval
 - A average of peak discharge of preceding 100 years
 - The peak discharge during preceding year will occur 100 years after
97. Convective storm rainfall is caused by
- Thermal or orographic convection
 - Frontal disturbances
 - Sudden barometric drop
 - Isolated barometric fall in area
98. A rock formation that contains water but is not capable of transmitting it in significant amounts, is known as
- Isotrophic
 - Intrusive
 - Aquitard
 - Aquiclude
99. The dimensions of storage coefficient
- LT^2
 - $L^{-1}T$
 - LT
 - Dimensionless
100. According to Kennedy's theory, the silt transporting power of a canal is proportional to
- $V^{3.5}$
 - V^3
 - $V^{2.5}$
 - V^2
101. The uplift pressure on the roof of an inverted siphon is maximum when
- The canal is running with FSL
 - The drain is running with HFL
 - The canal is running dry
 - The drain is running dry
102. If the net positive suction head (NPSH) requirement for a pump is not satisfied, then
- No flow will take place
 - Efficiency will be low
 - Cavitation will be formed
 - Excessive power will be consumed
103. The reading of a pressure gauge fitted on a vessel is 25 bar. The atmospheric pressure is 1.03 bar and the value of g is 9.81 m/s^2 . The absolute pressure in the vessel is
- 23.97 bar
 - 25 bar
 - 26.03 bar
 - 34.84 bar
104. Sheet erosion is dominant in
- Regions of moderate rainfall
 - Regions of high rainfall
 - Arid regions
 - Semi-arid regions

105. The optimum depth of kor watering for a rice crop, is
- 23.0 cm
 - 19.0 cm
 - 17.5 cm
 - 13.5 cm
106. The usual detention time(hours) allowed in clarifloculator is
- 2
 - 3
 - 4
 - 5
107. The cleaning of slow sand filter is done by
- reversing the direction flow of water
 - passing air through the filter
 - passing a solution of alum and lime through the filter
 - scraping off the top layers of sand and admitting water
108. BOD removal in extended aeration process is
- 85%
 - 40%
 - 95%
 - 60%
109. Self-cleansing velocity is
- velocity at dry weather flow
 - velocity at which no accumulation remains in the drains
 - velocity of water at flushing
 - velocity of water in a pressure filter
110. Which of the following gases has the highest affinity for blood haemoglobin?
- Carbon dioxide
 - Oxygen
 - Carbon monoxide
 - Nitrogen
111. A well conditioned triangle has no angle less than
- 15°
 - 30°
 - 60°
 - 90°
112. The line of sight is kept as high above ground surface as possible to minimise the error in the observed angles due to
- shimmering
 - horizontal refraction
 - vertical refraction
 - both shimmering and horizontal refraction
113. For locating a distant object visible from two transit stations, the method usually preferred to, is
- angles and distances from transit stations
 - angles from two transit stations
 - distances from two transit stations
 - angle from one transit station and distance from the other
114. While measuring the distance between two points along upgrade with the help of a 20 m chain, the forward end of the chain is shifted forward through a distance
- $20(\sin \theta - 1)$
 - $20(\cos \theta - 1)$
 - $20(\tan \theta - 1)$
 - $20(\sec \theta - 1)$
115. The operation of revolving a plane table about its vertical axis so that all lines on the sheet become parallel to corresponding lines on the ground, is known as
- levelling
 - centering
 - orientation
 - setting

PART III

02 — COMPUTER SCIENCE AND ENGINEERING/INFORMATION TECHNOLOGY

(Answer ALL questions)

56. In bottom up evaluation of a syntax direction definition, inherited attributes can
- Always be evaluated
 - Evaluation only done if the definition has synthesized attributes
 - Be evaluated only if the definition is L-attributed
 - None of the above
57. Assume that the SLR parser for a grammar G has n_1 states and the LALR parser for G has n_2 states. Hence which one is true?
- n_1 is necessarily less than n_2
 - n_1 is necessarily greater than n_2
 - n_1 is necessarily equal to n_2
 - None of the above
58. The grammar $S \rightarrow aSa \mid bS \mid c$ is
- LL(1) but not LR(1)
 - LR(1) but not LL(1)
 - Both LL(1) and LR(1)
 - Neither LL(1) nor LR(1)
59. The following grammar production belongs to which parser?
- $$S \rightarrow Aa \mid bAc \mid dc \mid bda$$
- $$A \rightarrow d$$
- LL(1)
 - SLR(1)
 - LALR(1)
 - None of the above
60. Reaching Definitions are calculated using
- $IN[B] = f_B(OUT[B])$;
 $OUT[B] = \bigwedge_{P, pred(B)} IN[P]$
 - $IN[B] = f_B(OUT[B])$;
 $OUT[B] = \bigwedge_{S, succ(B)} IN[S]$
 - $OUT[B] = f_B(IN[B])$;
 $IN[B] = \bigwedge_{S, succ(B)} OUT[S]$
 - $OUT[B] = f_B(IN[B])$;
 $IN[B] = \bigwedge_{P, pred(B)} OUT[P]$
61. What is the total number of child processes that are forked by the following code segment?
- ```
main()
{
 ...
 fork();
 fork();
 fork();
 ...
}
```
- 3
  - 4
  - 7
  - 8
62. A System software that places the absolute code into main memory, beginning with the initial address assigned by the assembler and, in which no address manipulation is performed is called a/an
- Absolute loader
  - Linker
  - Relocating Loader
  - Compile and go Loader
63. Convoy effect is a resultant of
- One CPU bound and many I/O bound processes
  - Many CPU and I/O bound processes
  - Many CPU bound processes and less I/O bound processes
  - Proper mix of CPU and I/O bound processes
64. In a paged memory, the page hit ratio is 0.45. The time required to access a page in secondary memory is equal to 100 ns. The time required to access a page in primary memory is 10 ns. The average time required to access a page is
- 3.0 ns
  - 59.5 ns
  - 68.5 ns
  - 78.5 ns

65. If there are 32 segments, each of size 1 kbytes, then the logical address should have
- 13 bits
  - 14 bits
  - 15 bits
  - 16 bits
66. In distributed systems the processes on a remote systems are identified by their
- Host identifier
  - Host name and identifier
  - Identifier
  - Process identifier
67. Link and site failure in distributed systems is detected by
- Polling
  - Routing
  - Token passing
  - Handshaking
68. \_\_\_\_\_ is a framework for distributed objects using Borland Delphi.
- CORBA
  - DCOM
  - DDObjects
  - DDCom
69. Algorithms for distributed systems are difficult to design because of the
- Presence of shared memory
  - Presence of global time
  - Absence of global time
  - Presence of synchronized clocks
70. In a distributed system, if all writes requested by the applications at clients are also carried out at the servers immediately, the writing policy is called
- Write-through
  - Delayed-writing
  - Write on close
  - Write resolution
71. Which traversal
- inorder
  - level order
  - postorder
  - preorder
72. Which of the following statement(s) is/are TRUE?
- A hash function takes a message of arbitrary length and generates a fixed length code.
  - A hash function takes a message of fixed length and generates a code of variable length.
  - A hash function may give the same hash value for distinct messages.
- 1 only
  - 2 and 3 only
  - 1 and 3 only
  - 2 only
73. What is the worst case time complexity of quicksort?
- $O(n^2)$
  - $O(n)$
  - $O(n \log_2 n)$
  - $O(\log_2 n)$
74. Which of the following is true?
- Hashing is a technique used for performing insertions, deletions and finds in constant average time.
  - Standard deletion cannot be performed in an open addressing hash table.
  - Extendible hashing is used when the amount of data is too large to fit in main memory.
- (i)
  - (iii)
  - (i) and (iii)
  - all the above

75. What is the condition for the existence of Eulerian cycle in an undirected graph?
- every vertex has even degree, and all of its vertices with nonzero degree are connected
  - one vertex has odd degree and every other vertex has even degree, and all of its vertices with nonzero degree are connected
  - two vertices have odd degree and every other vertex has even degree, and all of its vertices with nonzero degree are connected
  - the graph is fully connected
76. Let  $A$  be the problem of finding a Hamiltonian cycle in a graph  $G = (V, E)$ , with  $|V|$  divisible by 3 and  $B$  be the problem of determining if Hamiltonian cycle exists in such graphs. Which one of the following statements is true?
- $A$  is NP-hard, but  $B$  is not
  - Both  $A$  and  $B$  are NP-hard
  - $A$  is not, but  $B$  is NP-hard
  - Neither  $A$  nor  $B$  is NP-hard
77. Which of the following uses memoization?
- Dynamic programming approach
  - Greedy approach
  - Divide and conquer approach
  - None of the above
78. Let  $W(n)$  and  $A(n)$  denote respectively, the worst case and average case running time of an algorithm executed on an input of size  $n$ . Which of the following is ALWAYS TRUE?
- $A(n) = \Omega(W(n))$
  - $A(n) = \theta(W(n))$
  - $A(n) = O(W(n))$
  - $A(n) = o(W(n))$
79. Floyd-Warshall algorithm utilizes \_\_\_\_\_ to solve the all-pairs shortest paths problem on a directed graph in \_\_\_\_\_ time.
- Greedy algorithm,  $\theta(V^3)$
  - Greedy algorithm,  $\theta(V^2 \lg n)$
  - Dynamic programming,  $\theta(V^3)$
  - Dynamic programming,  $\theta(V^2 \lg n)$
80. A carry look ahead adder is frequently used for addition because
- It costs less
  - It is faster
  - It uses fewer gates
  - All of these.
81. Which registers of the processor are connected to Memory Bus?
- PC and IR
  - IR and MAR
  - PC and MAR
  - MAR and MDR
82. In CISC architecture most of the complex instructions are stored in
- Register
  - Diodes
  - Transistors
  - CMOS
83. Consider a non-pipelined processor with a clock rate of 2.5 gigahertz and average cycles per instruction of 4. The same processor is upgraded to a pipelined processor with five stages but due to the internal pipeline delay, the clock speed is reduced to 2 gigahertz. Assume there are no stalls in the pipeline. The speed up achieved in this pipelined processor is
- 3.2
  - 3.0
  - 2.2
  - 2.0
84. Consider a 4-way set associative cache consisting of 128 lines with a line size of 64 words. The CPU generates a 20-bit address of a word in main memory. The numbers of bits in the TAG, LINE and WORD fields are respectively
- 9,6,5
  - 7,7,6
  - 7,5,8
  - 9,5,6

85. Fast Fourier Transform algorithms exploit
- Summetry and periodicity
  - Four basic properties of phase factor
  - Complex multiplications
  - Indexing and addressing operations
86. Low pass butterworth filters are
- Nonmonotonic in stop band
  - All-pole filters
  - Pole-zero filters
  - Having magnitude squared frequency response
87. How many complex multiplications are need to be performed for each FFT algorithm?
- $(N/2)\log N$
  - $N\log_2 N$
  - $(N/2)\log_2 N$
  - None of the above
88. The realization of FIR filter by frequency sampling realization can be viewed as cascade of how many filters?
- Two
  - Three
  - Four
  - None of the above
89. Terminal emulation allows the following operation to be performed:
- A dummy terminal to pretend that it is a personal computer
  - A dummy terminal to produce a local echo
  - A personal computer to pretend that it is a computer terminal
  - Both a and b
90. Many low-speed channels are interwove into one high-speed transmission by the following:
- Frequency-division multiplexer
  - Time-division multiplexer
  - Both a and b
  - None of the above
91. The frequency range at which the land coaxial cables will be used is
- $10^6$  to  $10^8$  Hz
  - $10^{10}$  to  $10^{11}$  Hz
  - $10^3$  to  $10^4$  Hz
  - $10^{14}$  to  $10^{15}$  Hz
92. The number of cross point needed for 10 lines in a cross point switch is full duplex in nature and the number of self connection is
- 100
  - 45
  - 50
  - 90
93. Consider the relation employee(name, sex, supervisorName) with name as the key. supervisorName gives the name of the supervisor of the employee under consideration. What does the following Tuple Relational Calculus query produce?
- $$\{e.name \mid employee(e) \wedge (\forall x)[\neg employee(x) \vee x.supervisorName \neq e.name \vee x.sex = "male"]\}$$
- Names of employees with a male supervisor
  - Names of employees with no immediate male subordinates
  - Names of employees with no immediate female subordinates
  - Names of employees with a female supervisor
94. In distributed databases, location transparency allows for database users, programmers and administrators to treat the data as if it is at one location. A SQL query with location transparency needs to specify:
- Inheritances
  - Fragments
  - Locations
  - Local formats

95. If T consists of 500000 transactions, 20000 transaction contain bread, 30000 transaction contain jam, 10000 transaction contain both bread and jam. What is the confidence of buying bread with jam?
- 33.33%
  - 66.66%
  - 45%
  - 50%

96. Which of the following is true regarding referential integrity?
- Every primary key value must match a primary key value in an associated table
  - Every primary key value must match a foreign key value in an associated table
  - Every foreign key value must match a primary key value in an associated table
  - Every foreign key value must match a foreign key value in an associated table

97. Which of the following is true concerning a global transaction?
- The required data are at local site and the distributed DBMS routes requests as necessary
  - The required data are located in at least one non local site and the distributed DBMS routes requests as necessary
  - The required data are at local site and the distributed DBMS passes the request to only the local DBMS.
  - The required data are located in at least one non local site and the distributed DBMS passes the request to only the local DBMS.

98. The cyclomatic complexity of each of the modules A, B and C shown in the figure is 5. What is the cyclomatic complexity of the sequential integration shown?

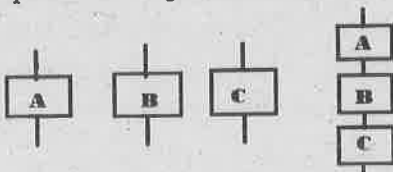

- 13
- 15
- 16
- 12

99. Which of the given statement(s) is/are true?
- S1 : Coupling is the organization of various modules for consistency.
- S2 : Cohesion is the degree of interdependence between modules.
- S3 : If coupling is low and cohesion is high, it is easier to change a module without affecting others.
- S1 and S2 only
  - S3 only
  - S1, S2, S3
  - S1 only

100. Pair the activities in Software Development Life Cycle.

|                         |                                       |
|-------------------------|---------------------------------------|
| I. Requirements Capture | 1. Module development and integration |
| II. Design              | 2. Domain Analysis                    |
| III. Implementation     | 3. Structural and Behavior Modeling   |
| IV. Maintenance         | 4. Performance Tuning                 |

- I - 3, II - 2, III - 4, IV - 1
- I - 2, II - 3, III - 1, IV - 4
- I - 3, II - 2, III - 1, IV - 4
- I - 2, II - 3, III - 4, IV - 1

101. A 4<sup>th</sup> Generation Technique is a package of
- CASE Tools
  - Software Programs
  - Software Tools
  - Agility Development

102. A report of software projects states: "Over 30% of software projects are cancelled before completion and over 70% fail to deliver expected features". What is the reason for this?

- Lack of Quality Control
- Poor Change Management
- Poor Testing
- Improper Requirements management

103. Identify the testing which covers the entire functionality of a product but does not cover features of the product.
- Breadth Testing
  - Confirmation Testing
  - Domain Testing
  - Black box Testing
104. Find the total number of feasibility studies needed in Requirement Analysis?
- Two
  - Three
  - Four
  - Five
105. Identify the model which describes the static structure of the system using object classes and their relationships?
- Structural model
  - Subsystem model
  - Dynamic model
  - Sequence model
106. Which of the following in the below list is not a part of a software test design document?
- Test plan
  - Test Design Specification
  - Test Case Specification
  - Test log
107. Software Maturity Index =  $[Mt - (Fa + Fc + Fd)]/Mt$ . What is Fc?
- Number of deleted modules in current version compared to the previous version
  - Number of added modules in current version
  - Number of changed modules in current version
  - Number of changed modules in existing version
108. Observed states are
- Unseen scenarios
  - Positive scenarios
  - Calculated Negative Variables
  - Calculated Variables and Constraints
109. Classifying under multiple class labels is
- Binary classification
  - Naïve Bayes Classification
  - N-ary classification
  - Multi-class Classification
110. The measure of the degree to which nodes in a graph tend to cluster together is called
- Entropy
  - Clustering co-efficient
  - Inter-cluster measure
  - Intra-cluster measure
111. True negative is
- correctly rejected
  - incorrectly identified
  - correctly identified
  - incorrectly rejected
112. Propositional logic is
- Context dependent
  - Context independent
  - Context variant
  - None of the above
113. In Cellular communication, during dynamic channel assignment strategy, the base station requests channel from
- MSC
  - Neighbouring cell
  - Neighbouring cluster
  - Neighbouring base station
114. An optional central base used to connect stationary or mobile wireless station to a wireless network station is called
- Point to point
  - Multi point
  - Network point
  - Access point
115. Which of the following statement is true about *spread spectrum*?
- It uses a narrow band frequency
  - Spread Spectrum allocates disjoint resources (frequency or time slots depending on the access system) to each user
  - Spread Spectrum signals can be picked up by simple receivers
  - Spread spectrum signals are hard to jam and identify

## PART III

## 03 – ELECTRICAL AND ELECTRONICS ENGINEERING

(Answer ALL questions)

56. An electrical circuit with 10 branches and 7 junctions will have
- 10 loop equations
  - 4 loop equations
  - 3 loop equations
  - 7 loop equations
57. A 0.5 metre long conductor carrying a current of 2 amperes is placed in a magnetic field having the flux density of  $0.05 \text{ wb/m}^2$ . What will be the amount of force experienced by the conductor?
- 1 N
  - 2 N
  - 0.05 N
  - 0.5 N
58. When two waves are  $90^\circ$  out of phase?
- each has its peak value at the same time
  - each has its minimum value at the same time
  - one has its peak value when the other has zero value
  - one has its positive peak when the other has its negative peak
59. Which of the following statements is correct?
- The strength of magnetic flux in a simple magnetic field continuously increases from initial value to final value
  - The strength of magnetic flux in a simple magnetic field continuously decreases from initial value to final value
  - The strength of magnetic flux in simple magnetic field is constant and has same value in every part of the magnetic field
  - None of the above statements is correct
60. If the effective voltage of the sinusoidal voltage is 11 volts. What will be the average value of sinusoidal voltage?
- 5 volts
  - 10 volts
  - 1.1 volts
  - 11 volts
61. The Fourier series expansion of an even periodic function contains
- Sine terms
  - Constant terms
  - Cosine terms
  - Harmonics
62. What will happen if the frequency of power supply in a pure capacitive circuit is doubled?
- The current will be reduced to half
  - The current will also be doubled
  - The current will remain same
  - The current will increase by four fold
63. If RC is the time constant of the R-C circuit, how much time the capacitor will take to get fully charged?
- RC seconds
  - 4 RC seconds
  - 3 RC seconds
  - 5 RC seconds
64. If the number of turns of a coil in a magnetic circuit is doubled then the winding inductance value of the coil is
- doubled
  - the same
  - halved
  - squared

65. Mutual torque of a doubly excited system is a function of
- $\delta$
  - $2\delta$
  - $\sin \delta$
  - $\sin 2\delta$
- where  $\delta$  is the angle of the rotor position.
66. When a single phase winding is excited with single phase supply ( $V_s, f_s$ ) then it produces
- a unidirectional rotating magnetic field at angular velocity,  $\omega_s$
  - a pulsating magnetic field at frequency,  $f_s$
  - two magnetic fields rotating in opposite direction at angular velocity,  $\omega_s$
  - both b and c
67. Induction motor at no-load operates with poor factor because
- it needs more reactive power to magnetise the air-gap
  - its real power consumption is less
  - its magnetising reactance is much larger than equivalent resistance
  - all of the above
68. A slip ring induction motor can develop maximum torque at starting if
- rotor resistance is made zero
  - rotor leakage reactance is made zero
  - rotor resistance is adjusted to a value equal to rotor leakage reactance
  - magnetizing reactance is much higher than equivalent resistance
69. All sequence networks are connected in series for the following fault
- SLG fault
  - LL fault
  - LLG fault
  - 3 Phase fault
70. Fault level means
- fault current
  - fault MVA
  - voltage at the point of fault
  - fault power factor
71. Which one of the following relays has the capability to anticipate the possible major fault in a transformer?
- Over current relay
  - Differential relay
  - Buchholz relay
  - Over fluxing relay
72. When a phase shifting transformer's taps are moved in such a direction as to advance the phase position?
- var flows will increase
  - var flows will decrease
  - there will be an increase in power flow in the line
  - voltage will be increased
73. On high voltage line under peak load conditions var compensation is provided by using
- series inductor
  - shunt capacitors
  - shunt inductors
  - any of the above
74. The demand factor for a residential load is about
- 2.1
  - 1.2
  - 0.2
  - 0.7
75. Phase shifting transformer is employed for
- Regulating bus voltage
  - Regulating power flow though the transmission line
  - Regulating reactive power flow
  - Regulating inrush current

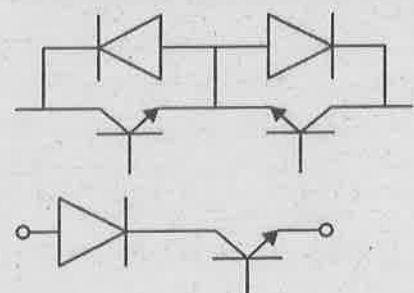
76. Commutation overlap angle  $\mu$  is influenced by
- Harmonics on ac side
  - Source inductance
  - Current margin
  - AC bus strength
77. Weak AC bus is characterized by
- High Short Circuit Capacity
  - High Short Circuit Ratio
  - Low Short Circuit Capacity
  - Low Thevenin equivalent reactance viewed from AC bus
78. The power reversal in HVDC link is achieved by
- Current reversal
  - Voltage reversal
  - VDCOL operation
  - Opening and closing DC breakers
79. The value of damping coefficient at the point, where the root loci of a second order system crosses the imaginary axis with critical gain is
- zero
  - negative
  - unity
  - positive
80. The lag compensation when provided for a second order system, upon proper design
- Increases the bandwidth and the phase margin
  - Increases the bandwidth and decreases the phase margin
  - Decreases the bandwidth and Increases the phase margin
  - Decreases the bandwidth and the phase margin
81. Correction to be applied at the corner frequency for the Bode's asymptotes, when complex conjugate zeros occur with damping factor of 0.1 is,
- +14 dB
  - +6 dB
  - 0 dB
  - 14 dB
82. Consider a system whose transfer function is given by  $G(s) = 3/[(s)(s+3)]$ . The steady state response of the system for an input  $u(t) = 3 \sin(3t)$  is given by
- $3/\sqrt{6} \sin(5t - \pi/4)$
  - $1/\sqrt{6} \sin(5t - \pi/4)$
  - $3/\sqrt{6} \sin(15t - 3\pi/4)$
  - $1/\sqrt{6} \sin(15t - 3\pi/4)$
83. A given  $G(s)$  polynomial has its roots at -1, -2 and -3 respectively. Location of poles when the axis of  $s$  plane is shifted by one unit towards left by replacing  $s$  by  $s-1$  will be
- 2, -3 and -4
  - 1, -2 and -3
  - 0, -1 and -2
  - 1, 2 and 3
84. The centroid of the root locus for the system with transfer function  $G(s) = (s+1)/[(s+3)(s+5)]$ , is given by
- 1/15
  - 1/8
  - 7/2
  - 7
85. Identify four quadrant switch from the following:
- Diode connected in series
  - Two diodes connected in series
- 
86. Current crowding in devices is due to
- Voltage applied
  - Low  $dv/dt$
  - Excessive  $di/dt$
  - High  $dv/dt$

87. Maximum allowable temperature at the junction of devices will be -

- a. 50°C
- b. 75°C
- c. 15°C
- d. 200°C

88. SiC-based devices withstand far higher voltages and temperatures than their silicon counterparts. This is due to

- a. High mobility
- b. High mechanical strength
- c. Smaller conduction time
- d. Silicon carbide electrons need almost three times more energy to reach the conduction band as compared to silicon to restrict armature current

89. Identify self-extinguishable device

- a. GTO
- b. Diode
- c. Schottky diode
- d. SCR

90. A three phase VSI fed from a 900V battery is shown in the figure. The resistive load of 60 Ω/phase is connected. At 180° conduction of solid-state devices, the power consumed by the load in kW is

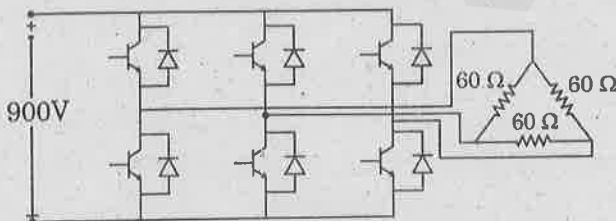

- a. 9 kW
- b. 27 kW
- c. 15.59 kW
- d. 54 kW

91. For a buck-boost converter input voltage varies from 32V to 72V. Assume that all components are ideal, inductor current is continuous and output voltage is ripple free. The range of duty ratio  $D$  of the converter for which the output voltage remains constant at 48V is

- a.  $1/3 \leq D \leq 2/3$
- b.  $2/3 \leq D \leq 3/4$
- c.  $2/5 \leq D \leq 3/5$
- d.  $0 \leq D \leq 1$

92. A six-pulse thyristor bridge rectifier is connected to a balanced three-phase, 50 Hz AC source. Assuming that the DC output current of the rectifier is constant, the lowest harmonic component in the AC input current is

- a. 100 Hz
- b. 150 Hz
- c. 250 Hz
- d. 300 Hz

93. The 8085 instruction that can be employed for checking if the contents of Accumulator is an odd number, is:

- a. ORI 01 or RAL
- b. ANI 01 or RAR
- c. XRI 01 or RLC
- d. XRI FF or RLC

94. In the program shown, how many times the 'NOP' instruction is executed?

```
MVI A, 03
Repeat: RAL
 NOP
 JNC Repeat
```

- a. 7
- b. 9
- c. 3
- d. 1

95. The 8085 instruction that is relevant for receiving through the pin SID, employing serial communication, is:
- SERIAL IN
  - SIM – Set Interrupt Mask
  - IN 8-bit port address
  - RIM – Read Interrupt Mask
96. When Code Segment of  $\mu P$  8086 contains 1234h and its Instruction pointer contains 9ABCh, the next instruction is fetched from:
- 9BDF4h
  - 1BDFCh
  - 9BD04h
  - 1BD0Ch
97. The address bus width and memory addressing capacity of  $\mu P$  8086, are respectively:
- 16 bit long and 64 Kbyte
  - 8 bit long and 256 byte
  - 20 bit long and 1 Mbyte
  - 24 bit long and 16 Mbyte
98. A non-anticipative system is a
- Static System
  - Dynamic System
  - Causal System
  - Both b and c
99. If  $x(n) = \{1, 2, 3, 0, 4, 0, 6\}$  then circularly shifted signal  $x(n+2) =$
- $\{1, 2, 3, 0, 4, 0, 6, 0, 0\}$
  - $\{3, 0, 4, 0, 6, 1, 2\}$
  - $\{3, 4, 5, 0, 6, 0, 8\}$
  - $\{0, 0, 1, 2, 3, 0, 4, 0, 6\}$
100. A system described by  $H(z) = z(z+1)/(z-2)(z+2)$ . The initial value of the system is,
- 1
  - 1/4
  - 4
  - Infinite
101. The breakdown criterion in a uniform field electrode gap is
- $\alpha^{-\gamma d} = 1$
  - $\alpha = \frac{\eta}{(1-\gamma)}$
  - $\gamma e^{\alpha d} = 1$
  - $\gamma e^{-\alpha d} = 1$
102. Time lag for breakdown is
- time difference between instant of applied voltage and occurrence of breakdown
  - time taken for the voltage to rise before breakdown occurs
  - time required for gas to breakdown under pulse application
  - none of the above
103. Corona occurs before the breakdown in a sphere to ground air gap when ratio of gap distance to the radius of sphere is
- >1.0
  - >3.0
  - >10
  - <1.0
104. Minimum sparking potential of air is about
- 100 V
  - 4.4 kV
  - 40 V
  - 325 V
105. Winds having following speed are suitable to operate wind turbines.
- 5 – 25 m/s.
  - 10 – 35 m/s
  - 20 – 45 m/s
  - 30 – 55 m/s

106. In testing with a resonant transformer, the output voltage is
- rectangular wave
  - triangular wave
  - trapezoidal wave
  - pure sine wave
107. The approximate value of time to front in an impulse voltage generator is
- $3R_1C_1$
  - $2.3R_1C_1$
  - $3R_1(C_1C_2)/(C_1 + C_2)$
  - $0.7(R_1 + R_2)(C_1 + C_2)$
108. An oscillatory impulse waveform is represented by
- $e^{-at} \cos bt$
  - $e^{at} \cos bt$
  - $e^{-at} \sin bt$
  - $e^{-at} - e^{-bt}$
109. Ward-Leonard controlled DC drives are generally used for \_\_\_\_\_ excavators.
- Light duty
  - Medium duty
  - Heavy duty
  - All the above
110. Which of the following motors are best suited for the rolling mills?
- Slip ring induction motor
  - Squirrel cage induction motor
  - DC motor
  - Synchronous motor
111. A 220V shunt motor takes 10A when running at 600 rpm. It has an armature resistance of  $0.15 \Omega$ . Determine the armature current if the magnetic flux is weakened by 20%.
- 25A
  - 50A
  - 100A
  - 200A
112. Machines with more than two brush sets per pairs of poles are
- Metadynes
  - Amplidynes
  - Universal motor
  - Schrage motor
113. The unit of luminous flux is
- Watt/m
  - Lumen
  - Lumen/m
  - Lumen/m<sup>2</sup>
114. Which of the following instrument is used for comparison of candle powers of different sources?
- Photometer
  - Radiometer
  - Bunsen meter
  - Candle meter
115. The area under the speed - time curve represents the
- Acceleration of the train
  - Time taken by the train
  - Distance travelled by the train
  - Crest speed

**PART III**
**04 - ELECTRONICS AND COMMUNICATION ENGINEERING**

(Answer ALL questions)

56. The Nodal method of circuit analysis is based on
- KVL and Ohm's law
  - KCL and Ohm's law
  - KCL and KVL
  - KCL, KVL and Ohm's law

57. The voltage across the terminals 'a and b' in Fig. is

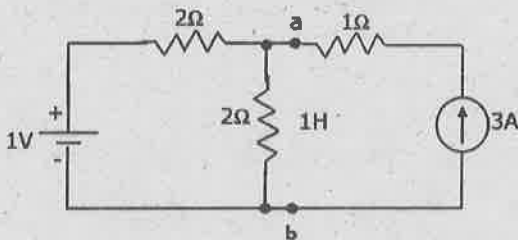

- 0.5V
- 3.0V
- 3.5V
- 4.0V

58. The circuit shown in the figure represents a

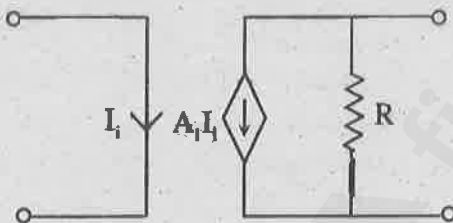

- Voltage controlled voltage source
- Voltage controlled current source
- Current controlled voltage source
- Current controlled current source

59. Superposition theorem is NOT applicable to networks containing

- Nonlinear elements
- Dependent voltage sources
- Dependent current sources
- Transformers

60. In the circuit shown below, the Norton equivalent current in amperes with respect to terminals P and Q is

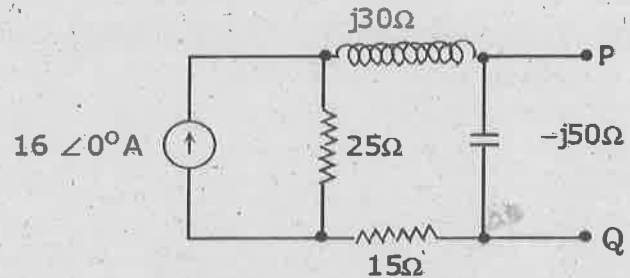

- $6.4 - j 4.8$
- $6.56 - j7.87$
- $10 + j 0$
- $16 + j 0$

61. Norton's theorem states that a complex network connected to a load can be replaced with an equivalent impedance

- In series with a current source
- In parallel with a voltage source
- In series with a voltage source
- In parallel with a current source

62. In the following figure,  $C_1$  and  $C_2$  are ideal capacitors.  $C_1$  has been charged to 12 V before the ideal switch S is closed at  $t = 0$ . The current  $i(t)$  for all  $t$  is.

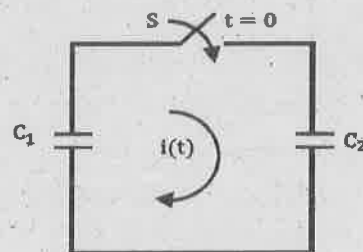

- zero
- a step function
- an exponentially decaying function
- an impulse function

63. A ramp voltage,  $v(t) = 100t$  Volts, is applied to an RC differentiating circuit with  $R = 5k\Omega$  and  $C = 4\mu F$ . The maximum output voltage is
- 0.2 volt
  - 2.0 volts
  - 10.0 volts
  - 50.0 volts

64. In the series circuit shown in figure, for series resonance, the value of the coupling coefficient  $K$  will be

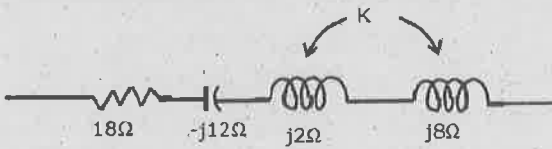

- 0.25
- 0.5
- 0.999
- 1.0

65. The RC circuit shown in the figure is

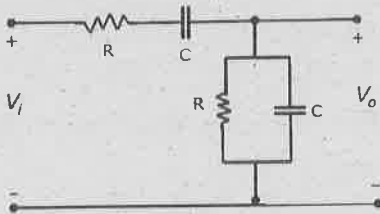

- a low-pass filter
- a high-pass filter
- a band-pass filter
- a band-reject filter

66. A 2-port network is shown in figure. The parameter  $h_{21}$  for this network can be given by

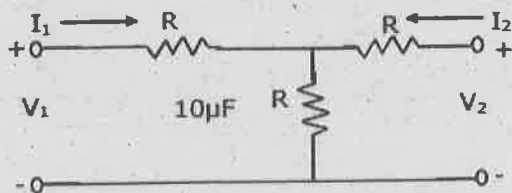

- +1/2
- 1/2
- +3/2
- 3/2

67. A Zener diode
- Tunneling of charge carriers across the junction
  - Thermo ionic emission
  - Diffusion of charge carriers across the junction
  - Accumulation of charge carriers across the junction

68. Which of the following is NOT associated with a P-N junction?

- Junction capacitance
- Charge storage capacitance
- Depletion capacitance
- Channel length modulation

69. The threshold voltage of an n-channel MOSFET can be increased by

- Increasing the channel dopant concentration
- Reducing the channel dopant concentration
- Reducing the gate-oxide thickness
- Reducing the channel length

70. A MOS capacitor made using p-type substrate is in the accumulation mode. The dominant charge in the channel is due to the presence of

- Holes
- Electrons
- Positively charged ions
- Negatively charged ions

71. In the following circuit employing pass transistor logic, all NMOS transistors are identical with a threshold voltage of 1 V. Ignoring the body-effect, the output voltages at P, Q and R are,

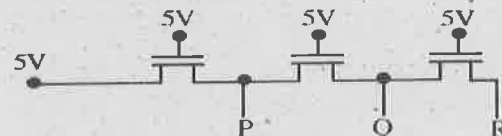

- 4 V, 3 V, 2 V
- 5 V, 5 V, 5 V
- 4 V, 4 V, 4 V
- 5 V, 4 V, 3 V

72. The current gain of a BJT is
- $\beta_m r_0$
  - $\beta_m / r_0$
  - $\beta_m r_\pi$
  - $\beta_m / r_\pi$
73. In a multi-stage RC-Coupled Amplifier the coupling capacitor.
- limits the low frequency response
  - limits the high frequency response
  - does not effect the frequency response
  - blocks the d.c components without effecting the frequency response
74. The Miller effect in the context of a Common Emitter amplifier explains
- an increase in the low-frequency cutoff frequency
  - an increase in the high- frequency cutoff frequency
  - a decrease in low- frequency cutoff frequency
  - a decrease in high- frequency cutoff frequency

75. In a differential Amplifier, CMRR can be improved by using an increased
- Emitter resistance
  - Collector resistance
  - Power supply voltage
  - Source resistance
76. The ideal Op-Amp has the following characteristics.
- $R_i = \infty, A = \infty, R_0 = 0$
  - $R_i = 0, A = \infty, R_0 = 0$
  - $R_i = \infty, A = \infty, R_0 = \infty$
  - $R_i = 0, A = \infty, R_0 = \infty$

77. The circuit in the figure is a

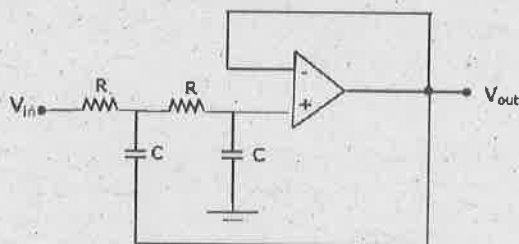

- Low- pass filter
- High- pass filter
- Band- pass filter
- Band- stop filter

78. An equivalent 2's complement representation of the 2's complement number 1101 is
- 110100
  - 001101
  - 110111
  - 111101
79. The output of a logic gate is '1' when all its inputs are at logic '0'. The gate is either
- a NAND or an EX-OR gate
  - a NOR or an EX-NOR gate
  - an OR or an EX-NOR gate
  - an AND or an EX-OR gate

80. For the logic circuit shown in Figure, the required input condition (A, B, C) to make the output (X)=1.

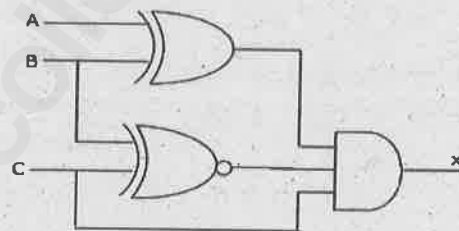

- 1, 0, 0
- 0, 0, 1
- 1, 1, 1
- 0, 1, 1

81. The logic realized by the circuit shown in figure is

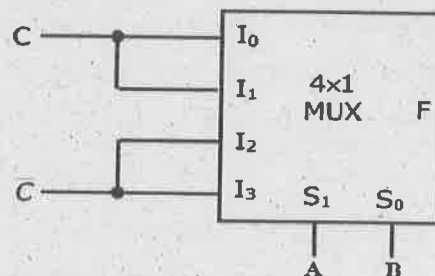

- $F = A \odot C$
- $F = A \oplus C$
- $F = B \odot C$
- $F = B \oplus C$

82. The circuit given below is a

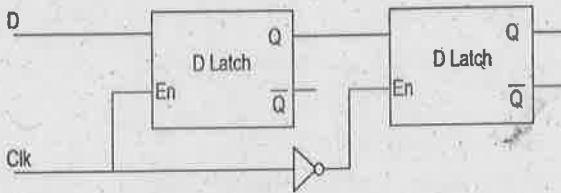

- J- K Flip- flop
- Toggle Flip- flop
- SR Flip- flop
- Master- Slave D Flip- flop

83. The minimum number of MOS transistors required to make a dynamic RAM cell is

- 1
- 2
- 3
- 4

84. The advantage of using a dual slope ADC in a digital voltmeter is that

- its conversion time is small
- its accuracy is high
- it gives output in BCD format
- it does not require a comparator

85. The resolution of a 4-bit counting ADC is 0.5 Volts. For an analog input of 6.6 Volts, the digital output of the ADC will be

- 1011
- 1101
- 1100
- 1110

86. The number of hardware interrupts (which require an external signal to interrupt) present in an 8085 microprocessor are

- 1
- 4
- 5
- 13

87. An I/O processor control the flow of information between

- cache memory and I/O device
- main memory and I/O device
- two I/O devices
- cache and main memories

88. The following sequence of instructions are executed by an 8085 microprocessor:

1000: LXI SP, 27FF  
 1003: CALL 1006  
 1006: POP H

The contents of the stack pointer (SP) and the HL register pair on completion or execution of these instruction are

- SP = 27FF, HL = 1003
- SP = 27FD, HL = 1003
- SP = 27FF, HL = 1006
- SP = 27FD, HL = 1006

89. The physical layer is responsible for

- Flow control
- Modulation and coding
- Congestion control
- medium access

90. In a coil with 1000 turns, if the flux through each turn is  $(t^2 - 2t)$  mWb, the magnitude of the induced emf in the coil at a time of 8sec is

- 1.4V
- 14V
- 1.4mV
- 1.4 $\mu$ V

91. For a reflector of diameter 10 meter, operating frequency=3 GHz, efficiency = 70%, gain of the antenna is approximately

- 1500
- 2800
- 2200
- none of the above

92. Which among the following is regarded as a condition of an ordinary endfire array?

- $\alpha < \beta d$
- $\alpha > \beta d$
- $\alpha = \pm \beta d$
- $\alpha \neq -\beta d$

93. The angle between electric and magnetic fields in a waveguide is :
- 90°
  - 0°
  - 180°
  - 360°
94. If the normalized admittance at a point on a transmission line to be matched is  $1+j1.47$ . Then the normalized susceptance of the stub used for shunt stub matching is:
- 1  $\Omega$
  - 1.47  $\Omega$
  - 1  $\Omega$
  - 1.47  $\Omega$
95. The cut off frequency of the TEM wave is
- 0
  - 1 GHz
  - 6 GHz
  - infinity
96. The approximate loaded Q due to dielectric loss for a dielectric resonator given the loss tangent is 0.0001 is:
- 1000
  - 500
  - 2000
  - 10000
97. If modulation index of an AM wave is changed from 0 to 1, the transmitted power
- Increased by 50%
  - Increased by 75%
  - Increased by 100%
  - Remains unaffected
98. If there are M messages and each message has probability  $p=1/M$ , the entropy is
- 0
  - 1
  - $\log_2 M$
  - $M \log_2 M$
99. Viterbi decoding is one of the most commonly used techniques in modern systems that are used to decode the data encoded by \_\_\_\_\_
- Block coding
  - Hamming coding
  - Convolution coding
  - CRC coding
100. A signal  $x(t) = 100 \cos(24\pi \times 10^3) t$  is ideally sampled with a sampling period of 50  $\mu\text{sec}$  and then passed through an ideal low pass filter with cutoff frequency of 15 kHz. Which of the following frequency is/are present at the filter output?
- 12 kHz only
  - 12 kHz and 8 kHz
  - 12 kHz and 9 kHz
  - 8 kHz only
101. In a BPSK signal detector, the local oscillator has fixed phase error of 20°. By what factor does this phase error deteriorate the SNR at the output?
- $\text{Cos}^2 20^\circ$
  - $\text{Cos}20^\circ$
  - $\text{Cos}40^\circ$
  - $\text{Cos}70^\circ$
102. If the number bits per sample in a PCM system is increased from  $n$  to  $(n+1)$ , the improvement in signal to quantization noise ratio will be
- 3 dB
  - 6 dB
  - $2n$  dB
  - $4n$  dB
103. The size of an IP address in IPv6 is \_\_\_\_\_
- 32 bits
  - 64 bits
  - 128 bits
  - 265 bits

104. What is the maximum number of IP addresses that can be assigned to hosts on a local subnet that uses the 255.255.255.224 subnet mask?
- 14
  - 15
  - 16
  - 30
105. If an Ethernet port on a router were assigned an IP address of 172.16.112.1/25, what would be the valid subnet address of this host?
- 172.16.112.0
  - 172.16.0.0
  - 172.16.96.0
  - 172.16.255.0
106. Due to Stimulated Raman Scattering phenomenon in a Mutichannel WDM system, optical power transfers
- between equal frequency channels
  - from longer to shorter wavelength channel
  - from shorter to longer wavelength channel
  - from lower to higher frequency channel
107. Many simultaneous light paths using same wavelength in a WDM wavelength Routing Network is possible with the use of
- Switches
  - Routers
  - wavelength converters
  - Add-Drop multiplexers
108. Which band/s specifies the operation range of Erbium doped fiber amplifier (EDFA)?
- By O band
  - By C band
  - By S band
  - All of the above
109. For the given sequence  $x(n) = 2\delta(n-2) - \delta(n+1) + 3\delta(n) - \delta(n-1) + 2\delta(n-2)$ , value of  $X(e^{j\omega})$  at  $\omega = \pi$  is
- 5
  - 7
  - 1
  - 9
110. The deviation of the group delay from a constant for the filters indicates the degree of
- symmetry of the phase
  - non-linearity of the phase
  - linearity of the phase
  - non-symmetry of the phase
111. The poles of a Chebyshev filter lie on
- circle
  - parabola
  - helix
  - ellipse
112. Which of the following statements are true for a causal and/or stable LTI system?
- All poles lie on the left half S Plane
  - ROC is the region to the right of right most pole
  - Some poles are Positive
- 1 and 2
  - 2 and 3
  - All of the above statements
  - None of the above statements
113. FIR filter is always stable because all of its
- poles are at the origin
  - zeros are at the origin
  - poles are at the infinity
  - zeros are at the infinity
114. A unity negative feedback system has an open-loop transfer function  $G(s) = \frac{K}{s(s+1)}$ . The gain K for the system to have a damping ratio of 0.25 is \_\_\_\_\_.
- 0
  - 400
  - 800
  - 500
115. A \_\_\_\_\_ is a data communication system within a building, plant, or campus, or between nearby buildings.
- LAN
  - MAN
  - WAN
  - None of the above

PART III

05 - MECHANICAL ENGINEERING

(Answer ALL questions)

56. The possible reactions at the Ball and socket joint support are
- $R_x, R_y, R_z, M_x, M_y,$  and  $M_z$
  - $M_x, M_y,$  and  $M_z$
  - $R_x, R_y$  and  $R_z$
  - $R_x, R_y,$  and  $M_z$
57. The purpose of the governor is
- To keep the output power constant at the crankshaft
  - To increase the power capacity of the engine
  - To increase the speed
  - To regulate the fuel supply
58. The force required to slide the body of weight 1000 N placed on horizontal surface of co-efficient friction 0.25 is
- 1000 N
  - 750 N
  - 500 N
  - 250 N
59. A body of mass 5 kg is thrown vertically upwards with the velocity 29.43 m/s from the ground. The time taken by it to reach the maximum height is
- 0
  - 2 s
  - 3 s
  - 4 s
60. Dynamic equilibrium or D'Alembert's principle for the body under rotation is expressed with the following equation (s)
- $\sum M = I\alpha$
  - $\sum F = 0$
  - $\sum F_x = 0, \sum F_y = 0, \sum F_z = 0, \sum M_x = 0, \sum M_y = 0, \sum M_z = 0$
  - $\sum F = ma$
61. For balancing of masses which are fixed on a shaft and rotating in the different planes perpendicular to the axis of the shaft, the following is to be satisfied
- Both force polygon and couple polygon are to be closed
  - D'Alembert's principle is to be satisfied
  - Inertia forces are to be balanced
  - Force polygon is to be closed
62. The circumferential stress induced in a thin-walled cylindrical vessel is
- $\frac{pD}{2t}$
  - $\frac{pD}{t}$
  - $\frac{pD}{4t}$
  - $\frac{pD}{3t}$
63. Centrifugal tension in belts
- reduces power transmission
  - increases power transmission
  - does not affect power transmission
  - increase power transmission at high speed and decreases it at lower speed
64. For a spur gear, the product of circular pitch and diametral pitch is equal to
- unity
  - module
  - $\pi$
  - $\frac{1}{\pi}$

65. If the lead angle of a worm is  $20^\circ$ , then helix angle will be
- $20^\circ$
  - $70^\circ$
  - $10^\circ$
  - $80^\circ$
66. When bevel gears having equal teeth and equal pitch angles connect two shafts whose axes intersect at right angles, then they are known as
- Angular bevel gears
  - Crown bevel gears
  - Internal bevel gears
  - Mitre gears
67. Write the structural formula for 12 speed gear box
- 3(1) 2(3) 2(6)
  - 3(1) 3(3) 2(9)
  - 4(1) 2(4) 2(8)
  - 3(1) 2(3)
68. When a helical compression spring is subjected to an axial compressive load, the stress induced in the wire is
- tensile stress
  - compressive stress
  - shear stress
  - bending stress
69. \_\_\_\_\_ designers must master in curve, surface, and solid concepts before they can truly create complex solid models and be productive in using CAD systems.
- CAD
  - CAM
  - CAE
  - CAD/CAM
70. \_\_\_\_\_ is described by sets of data points (control points) such as splines and Bezier curves.
- Circle
  - Analytic curve
  - Synthetic curve
  - Conics
71. A \_\_\_\_\_ should sort out precisely the edges and faces of a solid into hidden, visible and partially hidden/visible.
- hidden line algorithm
  - hidden surface algorithm
  - visibility techniques
  - homogeneity test
72. \_\_\_\_\_ is a planning technique, usually implemented by computer, that translates the end products into a detailed schedule for the raw materials and parts used in those end products.
- Aggregate production planning
  - Master production planning
  - Capacity planning
  - Material requirements planning
73. The \_\_\_\_\_ combines a fully integrated material handling system with automated processing stations.
- Flexible Manufacturing System
  - Group machine cell
  - Production flow analysis
  - Group technology

74. A quadrilateral elements has a minimum of four nodes and as many as \_\_\_\_\_ nodes.
- eleven
  - twelve
  - thirteen
  - fourteen

75. The physical region of interest is divided into elements and element types and appropriate interpolation functions are selected and is known as
- formulation phase
  - evaluation phase
  - assembly phase
  - solution phase

76. In the portion of iron-iron carbide phase diagram, what is the mass fraction of pearlite formed just below the eutectoid line for 0.52%C?

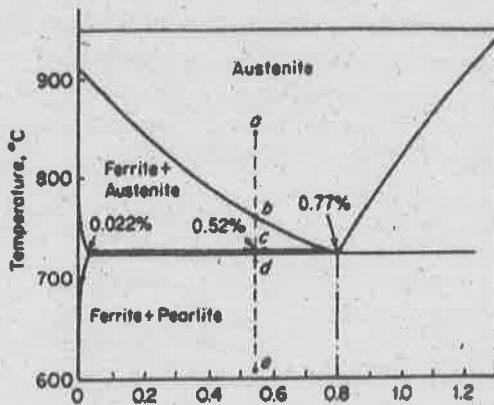

- 62.25%
  - 33.42%
  - 66.57%
  - 65%
77. Holloman-Jaffe parameter is (T-absolute temperature; t-time in hrs)
- $T(\log t + 18) \times 10^{-3}$
  - $t(\log T + 18) \times 10^{-3}$
  - $T(\log t + 18) \times 10^{-2}$
  - $t(\log T + 18) \times 10^{-2}$
78. Mechanical twins are found in
- SC
  - FCC
  - BCC and HCP
  - All of the above

79. Choose the wrong statement with respect to ceramics
- the strength of ceramics is higher than metals because their covalent and ionic bonding types are stronger than metallic bonding
  - Bonding in ceramics is more rigid and does not permit slip under stress
  - The inability to slip makes it much more difficult for ceramics to absorb stresses
  - The ceramics are more tougher than metals

80. The titanium above 883°C transforms to \_\_\_\_\_ structure from \_\_\_\_\_
- BCC, HCP
  - FCC, HCP
  - BCC, FCC
  - FCC, BCC

81. Maraging steels are strengthened due to \_\_\_\_\_
- A fine, highly dislocated and strong martensite
  - Fine dispersions of intermetallic of Fe, Ni, Ti, etc.
  - fine dispersions of alloy carbides in ferrite matrix
  - fine dispersions of Fe<sub>3</sub>C nucleated on dislocations in austenite

82. Microalloyed steel in which carbon percentage is
- <0.2
  - 0.2 - 0.4
  - 0.4 - 0.6
  - 0.6 - 0.77

83. The tool angle which helps in reducing the rubbing of the machined surface to the flank of the tool is
- Rake angle
  - Cutting edge angle
  - Clearance angle
  - Nose radius

84. If the surface tension of the liquid increases with increase in temperature, then its effect on welding results in
- Weld fluid flows outwards
  - Weld pool becomes deeper
  - Weld pool becomes shallower
  - None of the above
85. An Aluminium material whose density is  $2.7 \text{ gram/cm}^3$  is welded with an electrode of diameter of 1.2 mm at a feed rate of 50 mm per second. If the electrode efficiency is 0.75, then the deposition rate is
- $5 \times 10^{-4} \text{ kg/s}$
  - $1.14 \times 10^{-4} \text{ kg/s}$
  - $0.12 \times 10^{-4} \text{ kg/s}$
  - $2.85 \times 10^{-4} \text{ kg/s}$
86. Specific power consumption in metal cutting is reduced with increase of
- Cutting speed
  - Hardness and strength of metal
  - Surface finish
  - Feed rate/ depth of cut
87. A cubical casting of side 3 cm each takes 8 seconds for complete solidification. How much time a cube of same material with 6 cm each side will take for complete solidification?
- 16 seconds
  - 32 seconds
  - 64 seconds
  - 128 seconds
88. A CNC lathe is programmed and set to turn a diameter of 60 mm, but on trial run the diameter is found to be 60.1 mm. Which one of the following will ensure correct diameter during production?
- Increase the tool offset by 0.1 mm
  - decrease the tool offset by 0.1 mm
  - Increase the tool offset by 0.051 mm
  - decrease the tool offset by 0.05 mm
89. Which of the following can be used for checking the geometric accuracy of machine tool tables?
- CMM
  - Autocollimator
  - Laser interferometer
  - Laser micrometer
- 1, 2 and 4 only
  - 1, 3 and 4 only
  - 2 and 3 only
  - 1, 2 and 3 only
90. The height (in mm) for a 100 mm sine bar to measure a taper of  $30^\circ$  on a flat work piece is
- 33.33 mm
  - 86.6 mm
  - 100 mm
  - 50 mm
91. Assume that the surface roughness profile is triangular as shown schematically in the figure. If the peak to valley height is  $10 \mu\text{m}$ , the value of the surface roughness parameter  $R_t$  (in  $\mu\text{m}$ ) is
- 
- 5
  - 10
  - 6.67
  - 20
92. A cylindrical pin of  $30_{+0.01}^{+0.02} \text{ mm}$  diameter is electroplated. Plating thickness is  $1.0 \pm 0.005 \text{ mm}$ . The maximum diameter of the pin after plating is
- 31.025 mm
  - 31.0
  - 32.025
  - 32.03
93. Feeler gauge is used to measure
- diameter of a shaft
  - diameter of a hole
  - clearance or gap between parts
  - thickness of a part

94. Which of the following material is used to make stylus in CMMs?
- diamond
  - ruby
  - sapphire
  - inconel
95. The radius of the tip of the stylus in contact type surface roughness tester is usually
- 2 or 5  $\mu\text{m}$
  - 1 or 2  $\mu\text{m}$
  - 20 or 25  $\mu\text{m}$
  - < 1  $\mu\text{m}$
96. Which of the following is not the property of point functions?
- They have exact differential
  - They are independent of the path
  - They depend on initial and final states
  - They depend on the path followed
97. The relation between COP of heat pump and COP of a refrigerator is given as
- $(\text{COP})_{\text{HP}} = 1 - (\text{COP})_{\text{ref}}$
  - $(\text{COP})_{\text{HP}} = (\text{COP})_{\text{ref}}$
  - $(\text{COP})_{\text{HP}} = 1 + (\text{COP})_{\text{ref}}$
  - $(\text{COP})_{\text{HP}} = (\text{COP})_{\text{ref}} - 1$
98. A window air conditioner that consumes 1 kW of electricity when running and has a coefficient of performance of 4 is placed in the middle of a room, and is plugged in. The rate of cooling or heating this air conditioner will provide to the air in the room when running is
- 4 kJ/s, cooling
  - 1 kJ/s, cooling
  - 0.25 kJ/s, heating
  - 1 kJ/s, heating
99. According to Maxwell relations
- $\left(\frac{\partial T}{\partial V}\right)_S - \left(\frac{\partial P}{\partial S}\right)_V = 0$
  - $\left(\frac{\partial T}{\partial V}\right)_S + \left(\frac{\partial P}{\partial S}\right)_V = 0$
  - $\left(\frac{\partial V}{\partial T}\right)_S - \left(\frac{\partial S}{\partial P}\right)_V = 0$
  - $\left(\frac{\partial V}{\partial T}\right)_S + \left(\frac{\partial S}{\partial P}\right)_V = 0$
100. Air is throttled from 50° C and 800 kPa to a pressure of 200 kPa at a rate of 0.5 kg/s in an environment at 25° C. The change in kinetic energy is negligible, and no heat transfer occurs during the process. The power potential wasted (irreversibility) during this process is
- 59 kW
  - 0 kW
  - 47 kW
  - 119 kW
101. Water is boiling at 1 atm pressure in a stainless-steel pan on an electric range. It is observed that 2 kg of liquid water evaporates in 30 min. The rate of heat transfer in the water is
- 3.12 kW
  - 2.97 kW
  - 3.00 kW
  - 2.51 kW
102. Propane ( $\text{C}_3\text{H}_8$ ) is burned with 150 percent theoretical air. The air-fuel mass ratio for this combustion process is
- 5.5
  - 23.4
  - 10.5
  - 15.7
103. Which one of the following expresses the thermal diffusivity of a substance?
- $k/\rho c$
  - $\rho c/k$
  - $1/\rho kc$
  - $\rho/c k$
104. If heat and mass transfer take place simultaneously, the ratio of heat transfer coefficient to the mass transfer coefficient is a function of the ratio of
- Schmidt and Reynolds numbers
  - Schmidt and Prandtl numbers
  - Nusselt and Lewis numbers
  - Reynolds and Lewis numbers

105. A cross flow type air heater has an area of  $60 \text{ m}^2$ . The overall heat transfer coefficient is  $100 \text{ W/m}^2\text{K}$  and heat capacity of both hot and cold stream is  $1000 \text{ W/m K}$ . The value of NTU is
- 0.6
  - 60
  - 6
  - 600
106. A steel ball of mass  $1 \text{ kg}$  and specific heat  $0.5 \text{ kJ/kgK}$  is at temperature of  $60^\circ \text{ C}$ . It is dropped into  $1 \text{ kg}$  of water at  $20^\circ \text{ C}$ . The final steady state temperature of water ( $C_{\text{water}} = 4 \text{ kJ/kg K}$ ) is
- $25^\circ \text{ C}$
  - $20^\circ \text{ C}$
  - $30^\circ \text{ C}$
  - $35^\circ \text{ C}$
107. If the temperature of a solid state changes from  $127^\circ \text{ C}$  to  $527^\circ \text{ C}$ , then the change in emissive power is
- 1:8
  - 1:16
  - 1:32
  - 1:64
108. For air at a given temperature, as the relative humidity is increased isothermally,
- wet bulb temperature and specific enthalpy decreases
  - wet bulb temperature and specific enthalpy increases
  - wet bulb temperature increases and specific enthalpy decreases
  - wet bulb temperature decreases and specific enthalpy increases
109. If the thermal efficiency of a Carnot heat engine is  $40\%$ , the ratio of temperature of sink to that of source is
- 0.5
  - 0.6
  - 0.7
  - 0.4
110. Which one of the following is the dimension of specific weight of a liquid?
- $[\text{ML}^{-3} \text{ T}^{-2}]$
  - $[\text{ML}^3 \text{ T}^{-2}]$
  - $[\text{ML}^{-2} \text{ T}^{-2}]$
  - $[\text{ML}^2 \text{ T}^{-2}]$
111. How can relatively denser object be made to float on the less dense fluid?
- By altering the shape
  - By altering the forces acting on the object
  - By altering the shear forces acting on the object
  - None of the above
112. The continuity equation is based on the principle of
- conservation of mass
  - conservation of momentum
  - conservation of energy
  - conservation of force
113. Which property of the fluid accounts for the major losses in pipes?
- density
  - specific gravity
  - viscosity
  - compressibility
114. What is the relationship between Orificemeter diameter and pipe diameter?
- Orificemeter diameter is 0.5 times the pipe diameter
  - Orificemeter diameter is one third times the pipe diameter
  - Orificemeter diameter is one fourth times the pipe diameter
  - Orificemeter diameter is equal to the pipe diameter
115. Which forces are neglected to obtain Euler's equation of motion from Newton's second law of motion?
- Viscous force, Turbulence force, Compressible force
  - Gravity force, Turbulence force, Compressible force
  - Body force, Gravity force, Turbulence force
  - Viscous force, Turbulence force, Body force