

Question Paper Name: Electrical Engineering 30th May 2019 Shift 2
Subject Name: Electrical Engineering
Creation Date: 2019-05-29 13:39:28
Duration: 120
Total Marks: 120
Display Marks: No
Share Answer Key With Delivery Engine: Yes
Actual Answer Key: Yes

Electrical Engineering

Group Number : 1
Group Id : 39090049
Group Maximum Duration : 0
Group Minimum Duration : 120
Revisit allowed for view? : No
Revisit allowed for edit? : No
Break time: 0
Group Marks: 120

Mathematics

Section Id : 39090091
Section Number : 1
Section type : Online
Mandatory or Optional: Mandatory
Number of Questions: 10
Number of Questions to be attempted: 10
Section Marks: 10
Display Number Panel: Yes
Group All Questions: No

Sub-Section Number: 1
Sub-Section Id: 39090091
Question Shuffling Allowed : Yes

Question Number : 1 Question Id : 3909005761 Question Type : MCQ Option Shuffling : Yes Display Question Number : Yes
Single Line Question Option : No Option Orientation : Vertical
Correct Marks : 1 Wrong Marks : 0

If $A = \begin{bmatrix} 1 & 3 & 6 \\ 0 & -1 & 2 \\ 0 & 0 & 2 \end{bmatrix}$ then $A^{-1} = \dots$

Options :

1. $\frac{1}{2}[I - 2A - A^2]$

2. $\frac{1}{2}[I + 2A - A^2]$

3. $\frac{1}{2}[I + A - A^2]$

4. $\frac{1}{2}[I + A + A^2]$

Question Number : 2 Question Id : 3909005762 Question Type : MCQ Option Shuffling : Yes Display Question Number : Yes
Single Line Question Option : No Option Orientation : Vertical

Correct Marks : 1 Wrong Marks : 0

The value of $\int_C \vec{F} \cdot d\vec{r}$ where $\vec{F} = e^x \vec{i} + 2y \vec{j} - \vec{k}$ and C is the curve $x^2 + y^2 = 9$ and $z = 0$ is ...

Options :

1. 0

2. 1

3. 2

4. 3

Question Number : 3 Question Id : 3909005763 Question Type : MCQ Option Shuffling : Yes Display Question Number : Yes
Single Line Question Option : No Option Orientation : Vertical

Correct Marks : 1 Wrong Marks : 0

The expansion of e^z about $z = 1$ is ...

Options :

1. $1 + (z-1) + \frac{(z-1)^2}{2!} + \frac{(z-1)^3}{3!} + \dots$

2. $e \left[1 - (z-1) + \frac{(z-1)^2}{2!} - \frac{(z-1)^3}{3!} + \dots \right]$

3. $1 - (z-1) - \frac{(z-1)^2}{2!} + \frac{(z-1)^3}{3!} - \dots$

4. $e \left[1 + (z-1) + \frac{(z-1)^2}{2!} + \frac{(z-1)^3}{3!} + \dots \right]$

Question Number : 4 Question Id : 3909005764 Question Type : MCQ Option Shuffling : Yes Display Question Number : Yes
Single Line Question Option : No Option Orientation : Vertical

Correct Marks : 1 Wrong Marks : 0

If 1, 3, -2 are the Eigen values of the matrix A , then the Eigen values of $3A^3 + 5A^2 - 6A + 2I$ are

Options :

1. 4, 110, 10

2. 2, 100, 10

3. 4, 70, 10

4. 10, 40, 110

Question Number : 5 Question Id : 3909005765 Question Type : MCQ Option Shuffling : Yes Display Question Number : Yes
Single Line Question Option : No Option Orientation : Vertical

Correct Marks : 1 Wrong Marks : 0

Let X be a random variable with $E(X) = 10$ and $Var(X) = 25$. The positive values of a such that $Y = aX - b$ has expectation 0 and variance 1 is ...

Options :

1. $a = 2, b = 2$

2. $a = 2, b = 0.2$

3. $a = 0.2, b = 0.2$

4. $a = 0.2, b = 2$

Question Number : 6 Question Id : 3909005766 Question Type : MCQ Option Shuffling : Yes Display Question Number : Yes
Single Line Question Option : No Option Orientation : Vertical

Correct Marks : 1 Wrong Marks : 0

If $\frac{dy}{dx} = (x^3 + xy^2)e^{-x}$, $y(0) = 1$ and $h = 0.1$ then the value of $y(0.1)$ by simple Euler's method is ...

Options :

1. 0

2. 1

3. 1.005

4. 1.0005

Question Number : 7 Question Id : 3909005767 Question Type : MCQ Option Shuffling : Yes Display Question Number : Yes
Single Line Question Option : No Option Orientation : Vertical

Correct Marks : 1 Wrong Marks : 0

Let X be a random variable with probability density function $f(x) = \frac{1}{2}$, $-1 \leq x \leq 1$,

and let $Y = X^2$ then the correlation coefficient between X and Y is ...

Options :

1. -1

2. 1

3. 0

4. 0.5

Question Number : 8 Question Id : 3909005768 Question Type : MCQ Option Shuffling : Yes Display Question Number : Yes
 Single Line Question Option : No Option Orientation : Vertical

Correct Marks : 1 Wrong Marks : 0

Rate of convergence of the Newton-Raphson method is ...

Options :

1. 1
2. 2
3. 3
4. 4

Question Number : 9 Question Id : 3909005769 Question Type : MCQ Option Shuffling : Yes Display Question Number : Yes
 Single Line Question Option : No Option Orientation : Vertical

Correct Marks : 1 Wrong Marks : 0

Z- transform of $\frac{1}{2^n}, \left| \frac{1}{z} \right| < 2$ is ...

Options :

1. $\frac{2z}{2z-1}, \left| \frac{1}{2z} \right| < 1$
2. $\frac{z}{z-1}, \left| \frac{1}{2z} \right| < 1$
3. $\frac{2z}{1+2z}, \left| \frac{1}{2z} \right| > 1$
4. $\frac{z}{z+1}, \left| \frac{1}{2z} \right| > 1$

Question Number : 10 Question Id : 3909005770 Question Type : MCQ Option Shuffling : Yes Display Question Number : Yes
 Single Line Question Option : No Option Orientation : Vertical

Correct Marks : 1 Wrong Marks : 0

Laplace Transform of $t \cdot \sin at$ is ...

Options :

1. $\frac{1}{(s^2 + a^2)^2}$

2. $\frac{2as}{(s^2 - a^2)}$

3. $\frac{2as}{(s^2 + a^2)^2}$

4. $\frac{s}{(s^2 + a^2)}$

Electrical Engineering

Section Id :	39090092
Section Number :	2
Section type :	Online
Mandatory or Optional:	Mandatory
Number of Questions:	110
Number of Questions to be attempted:	110
Section Marks:	110
Display Number Panel:	Yes
Group All Questions:	No

Sub-Section Number:	1
Sub-Section Id:	39090092
Question Shuffling Allowed :	Yes

Question Number : 11 Question Id : 3909005771 Question Type : MCQ Option Shuffling : Yes Display Question Number : Yes
 Single Line Question Option : No Option Orientation : Vertical
 Correct Marks : 1 Wrong Marks : 0

Calculate potential difference between x and y for the circuit shown below

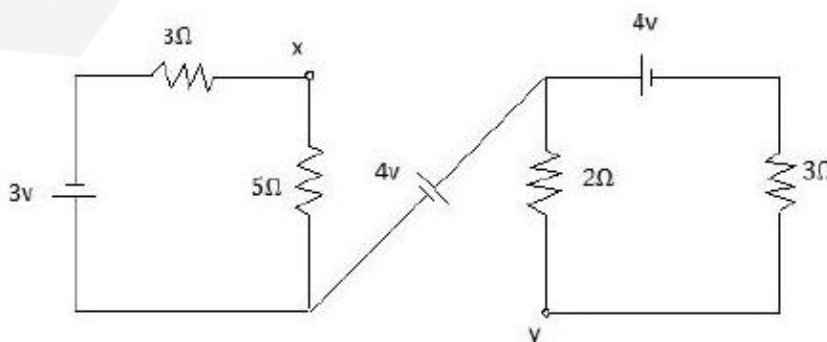

Options :

1. x is at 4.275 V higher than y
2. x is at 4.275 V lower than y
3. x is at 3.475 V higher than y
4. x is at 3.475 V lower than y

Question Number : 12 Question Id : 3909005772 Question Type : MCQ Option Shuffling : Yes Display Question Number : Yes
Single Line Question Option : No Option Orientation : Vertical

Correct Marks : 1 Wrong Marks : 0

Maximum power in terms of the Thevenin's voltage (V_{Th}) and load resistance (R_L) is

Options :

1. $(V_{Th})^2 / 4 R_L$
2. $(V_{Th})^2 \times 4 R_L$
3. $4(V_{Th})^2 / R_L$
4. $4 R_L / (V_{Th})^2$

Question Number : 13 Question Id : 3909005773 Question Type : MCQ Option Shuffling : Yes Display Question Number : Yes
Single Line Question Option : No Option Orientation : Vertical

Correct Marks : 1 Wrong Marks : 0

There are 5 sources in a network out of which 3 are dependent and 2 are independent.

How many sources are considered for the application of superposition principle?

Options :

1. 5
2. 3
3. 2
4. 0

Question Number : 14 Question Id : 3909005774 Question Type : MCQ Option Shuffling : Yes Display Question Number : Yes
Single Line Question Option : No Option Orientation : Vertical

Correct Marks : 1 Wrong Marks : 0

A 0.5 meter long conductor carrying a current of 2 amperes is placed in a magnetic field having the flux density of 0.05 wb/m^2 . What will be the amount of force experienced by the conductor?

Options :

1. 1 Newton
2. 2 Newton
3. 0.05 Newton
4. 0.5 Newton

Question Number : 15 Question Id : 3909005775 Question Type : MCQ Option Shuffling : Yes Display Question Number : Yes
Single Line Question Option : No Option Orientation : Vertical

Correct Marks : 1 Wrong Marks : 0

The energy required to charge a $10 \mu\text{F}$ capacitor to 100 V is

Options :

1. 0.01 J
2. 0.05 J
3. $5 \times 10^{-6} \text{ J}$
4. $10 \times 10^{-9} \text{ J}$

Question Number : 16 Question Id : 3909005776 Question Type : MCQ Option Shuffling : Yes Display Question Number : Yes
Single Line Question Option : No Option Orientation : Vertical

Correct Marks : 1 Wrong Marks : 0

If a coil has a resistance of 10Ω and an inductance of 1 H, what will be the value of current 0.1 second after switching on a 500 V d.c supply?

Options :

1. 3.16 A
2. 3.7 A

3. 4.0 A

4. 6.32 A

Question Number : 17 Question Id : 3909005777 Question Type : MCQ Option Shuffling : Yes Display Question Number : Yes
 Single Line Question Option : No Option Orientation : Vertical
 Correct Marks : 1 Wrong Marks : 0

Find the Thevenin's resistance for the given network between the terminals A and B.

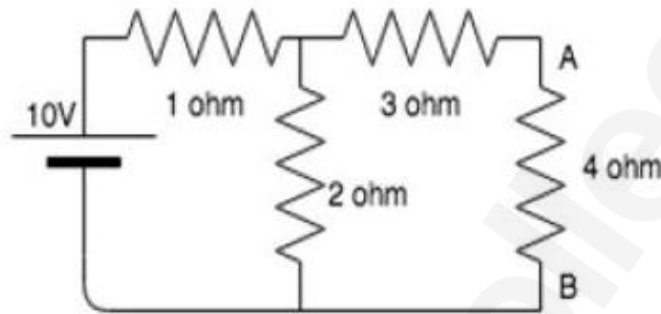

Options :

1. 4.34 Ω

2. 4.79 Ω

3. 3.43 Ω

4. 3.67 Ω

Question Number : 18 Question Id : 3909005778 Question Type : MCQ Option Shuffling : Yes Display Question Number : Yes
 Single Line Question Option : No Option Orientation : Vertical
 Correct Marks : 1 Wrong Marks : 0

Find the current in the 5 Ω resistor of the following circuit.

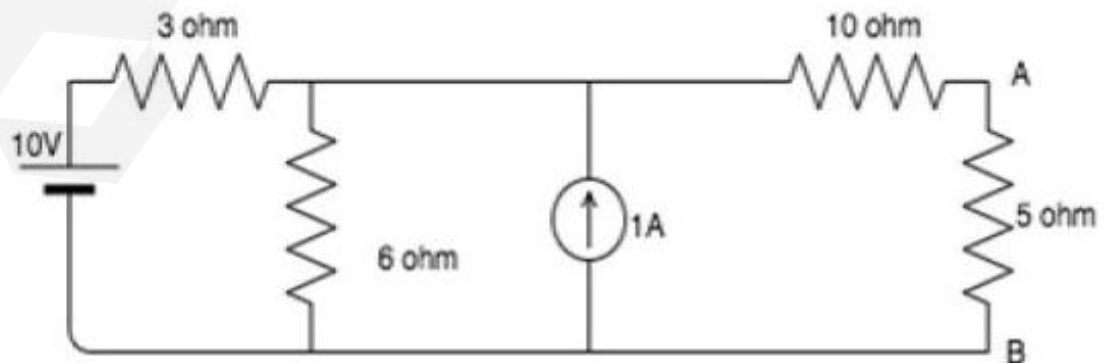

Options :

1. 1 A

2. 0.5 A

3. 1.5 A

4. 0.25 A

Question Number : 19 Question Id : 3909005779 Question Type : MCQ Option Shuffling : Yes Display Question Number : Yes
Single Line Question Option : No Option Orientation : Vertical

Correct Marks : 1 Wrong Marks : 0

A particular electric current is made up of two components: a dc current of 10 A and a sine wave ac current with peak value 14.14 A. The average value of electric current is

Options :

1. 24.14 A

2. 10 A

3. 4.14 A

4. 0 A

Question Number : 20 Question Id : 3909005780 Question Type : MCQ Option Shuffling : Yes Display Question Number : Yes
Single Line Question Option : No Option Orientation : Vertical

Correct Marks : 1 Wrong Marks : 0

The voltage phasor of a circuit is $10\angle 15^\circ$ V and the current phasor is $2\angle -45^\circ$ A. The active and reactive powers in the circuits are:

Options :

1. 10W, 17.32VAR

2. 5W, 8.66VAR

3. 20W, 60VAR

4. $20\sqrt{2}$ W, $10\sqrt{2}$ VAR

Question Number : 21 Question Id : 3909005781 Question Type : MCQ Option Shuffling : Yes Display Question Number : Yes
Single Line Question Option : No Option Orientation : Vertical

Correct Marks : 1 Wrong Marks : 0

A series R-L circuit with $R = 30 \Omega$ and $L = 15 \text{ H}$ has a constant voltage $V = 60 \text{ V}$ applied at $t = 0 \text{ sec}$. Determine the current in the circuit at $t = 0^+$

Options :

1. 1 A
2. 2 A
3. 3 A
4. 0 A

Question Number : 22 Question Id : 3909005782 Question Type : MCQ Option Shuffling : Yes Display Question Number : Yes
Single Line Question Option : No Option Orientation : Vertical

Correct Marks : 1 Wrong Marks : 0

Determine the resonant frequency ω (rad./sec.) for a series circuit with specifications:

$R = 10 \Omega$, $L = 0.1 \text{ H}$ and $C = 10 \mu\text{F}$

Options :

1. 500
2. 1000
3. 2000
4. 3000

Question Number : 23 Question Id : 3909005783 Question Type : MCQ Option Shuffling : Yes Display Question Number : Yes
Single Line Question Option : No Option Orientation : Vertical

Correct Marks : 1 Wrong Marks : 0

In a uniform electric field, field lines and equi-potential lines

Options :

1. are parallel to one another
2. intersects at 45°

3. intersects at 30°

4. are orthogonal

Question Number : 24 Question Id : 3909005784 Question Type : MCQ Option Shuffling : Yes Display Question Number : Yes
Single Line Question Option : No Option Orientation : Vertical

Correct Marks : 1 Wrong Marks : 0

The energy stored in the magnetic field of solenoid 30 cm long and 3 cm diameter wound with 1000 turns of wire carrying a current of 10 A is

Options :

1. 0.015 J

2. 0.15 J

3. 0.5 J

4. 1.15 J

Question Number : 25 Question Id : 3909005785 Question Type : MCQ Option Shuffling : Yes Display Question Number : Yes
Single Line Question Option : No Option Orientation : Vertical

Correct Marks : 1 Wrong Marks : 0

The line integral of the vector potential A around the boundary of a surface S represents

Options :

1. flux through surface S

2. flux density in the surface S

3. magnetic flux density

4. current density

Question Number : 26 Question Id : 3909005786 Question Type : MCQ Option Shuffling : Yes Display Question Number : Yes
Single Line Question Option : No Option Orientation : Vertical

Correct Marks : 1 Wrong Marks : 0

Two point charges $Q_1 = 10 \mu\text{C}$ and $Q_2 = 20 \mu\text{C}$ are placed at coordinates $(1, 1, 0)$ and $(-1, -1, 0)$ respectively. The total electric flux passing through a plane $z = 20$ will be

Options :

1. $7.5 \mu\text{C}$
2. $13.5 \mu\text{C}$
3. $15.0 \mu\text{C}$
4. $22.5 \mu\text{C}$

Question Number : 27 Question Id : 3909005787 Question Type : MCQ Option Shuffling : Yes Display Question Number : Yes
Single Line Question Option : No Option Orientation : Vertical

Correct Marks : 1 Wrong Marks : 0

The force between the charges 2C and -1C separated by a distance 1m in air is

Options :

1. $18 \times 10^9 \text{ N}$
2. $18 \times 10^6 \text{ N}$
3. $8 \times 10^6 \text{ N}$
4. $-18 \times 10^9 \text{ N}$

Question Number : 28 Question Id : 3909005788 Question Type : MCQ Option Shuffling : Yes Display Question Number : Yes
Single Line Question Option : No Option Orientation : Vertical

Correct Marks : 1 Wrong Marks : 0

A 10 kVA , $200/400$ single phase transformer is operating with secondary open circuited.

The input current should be about

Options :

1. 2 A
2. 10 A
3. 20 A
4. 50 A

Question Number : 29 Question Id : 3909005789 Question Type : MCQ Option Shuffling : Yes Display Question Number : Yes
Single Line Question Option : No Option Orientation : Vertical

Correct Marks : 1 Wrong Marks : 0

At full load, a transformer has iron loss of 900 W and copper loss of 1600 W. At what percentage of load, transformer will have maximum efficiency?

Options :

1. 133%
2. 125%
3. 75%
4. 66.6%

Question Number : 30 Question Id : 3909005790 Question Type : MCQ Option Shuffling : Yes Display Question Number : Yes
Single Line Question Option : No Option Orientation : Vertical

Correct Marks : 1 Wrong Marks : 0

The frequency of the impressed voltage of a transformer is increased keeping its magnitude fixed. Its

Options :

1. Hysteresis loss increases and eddy current loss decreases
2. Hysteresis loss decreases and eddy current loss increases
3. Hysteresis loss increases and eddy current loss remains constant
4. Hysteresis loss and eddy current loss both increases

Question Number : 31 Question Id : 3909005791 Question Type : MCQ Option Shuffling : Yes Display Question Number : Yes
Single Line Question Option : No Option Orientation : Vertical

Correct Marks : 1 Wrong Marks : 0

The ratio of starting torque in auto-transformer starting with x % tapping to that in direct-on-line starting of a 3-phase induction motor is equal to

Options :

1. x
2. $1/x$
3. \sqrt{x}
4. x^2

Question Number : 32 Question Id : 3909005792 Question Type : MCQ Option Shuffling : Yes Display Question Number : Yes
Single Line Question Option : No Option Orientation : Vertical
Correct Marks : 1 Wrong Marks : 0

A three phase transformer with delta-connected h.v. side and star-connected l.v. side can have the following symbol which also indicates the phase displacement

Options :

1. Dy1 or Dy11
2. Dy0 or Dy6
3. Dy1 only
4. Dy11 only

Question Number : 33 Question Id : 3909005793 Question Type : MCQ Option Shuffling : Yes Display Question Number : Yes
Single Line Question Option : No Option Orientation : Vertical
Correct Marks : 1 Wrong Marks : 0

A 4 pole d.c. generator with wave wound armature has 50 slots with 20 conductors per slot. The induced e.m.f. is 340 volts and the speed is 8500 r.p.m. The flux per pole will be

Options :

1. 2.4 mWb
2. 1.2 mWb
3. 14 mWb

4. 21 mWb

Question Number : 34 Question Id : 3909005794 Question Type : MCQ Option Shuffling : Yes Display Question Number : Yes
Single Line Question Option : No Option Orientation : Vertical
Correct Marks : 1 Wrong Marks : 0

If the armature current of a d.c. motor is increased keeping the field flux constant, then the developed torque

Options :

1. Decreases in inverse proportion
2. Remains constant
3. Increases proportional to the square of the current
4. Increases proportionally

Question Number : 35 Question Id : 3909005795 Question Type : MCQ Option Shuffling : Yes Display Question Number : Yes
Single Line Question Option : No Option Orientation : Vertical
Correct Marks : 1 Wrong Marks : 0

In a d.c. machine, the polarity of the interpole is

Options :

1. Same as that of the main pole behind for generators and that of the main pole ahead for the motors
2. Same as that of the main pole ahead for both generators and the motors
3. Same as that of the main pole ahead for generators and that of the main pole behind for the motors
4. Same as that of the main pole behind for both generators and the motors

Question Number : 36 Question Id : 3909005796 Question Type : MCQ Option Shuffling : Yes Display Question Number : Yes
Single Line Question Option : No Option Orientation : Vertical
Correct Marks : 1 Wrong Marks : 0

A d.c motor is run successively as a shunt motor, differential compound motor and cumulative compound motor with the same no-load speed. They can be arranged in the following order of decreasing full-load speeds

Options :

1. Cumulative compound, differential compound, shunt
2. Cumulative compound, shunt, differential compound
3. Shunt, differential compound, cumulative compound
4. Differential compound, shunt, cumulative compound

Question Number : 37 Question Id : 3909005797 Question Type : MCQ Option Shuffling : Yes Display Question Number : Yes Single Line Question Option : No Option Orientation : Vertical

Correct Marks : 1 Wrong Marks : 0

A d.c shunt motor has two additional resistances R_1 and R_2 in the field circuit and armature circuit respectively. The starting armature current can be kept to a minimum by keeping

Options :

1. R_1 maximum and R_2 maximum
2. R_1 minimum and R_2 maximum
3. R_1 maximum and R_2 minimum
4. R_1 minimum and R_2 minimum

Question Number : 38 Question Id : 3909005798 Question Type : MCQ Option Shuffling : Yes Display Question Number : Yes Single Line Question Option : No Option Orientation : Vertical

Correct Marks : 1 Wrong Marks : 0

In a synchronous generator in order to eliminate the fifth harmonic the chording angle should be.

Options :

1. 90°

2. 18°

3. 27°

4. 36°

Question Number : 39 Question Id : 3909005799 Question Type : MCQ Option Shuffling : Yes Display Question Number : Yes
Single Line Question Option : No Option Orientation : Vertical

Correct Marks : 1 Wrong Marks : 0

In relation to the synchronous machines, which one of the following statements is false?

Options :

1. In salient pole machines, the direct-axis synchronous reactance is greater than the quadrature-axis synchronous reactance

2. The damper bars help the synchronous motor self-start

3. Short circuit ratio is the ratio of the field current required to produce the rated voltage on open circuit to the rated armature current

4. The V-curve of a synchronous motor represents the variation in the armature current with field excitation, at a given output power

Question Number : 40 Question Id : 3909005800 Question Type : MCQ Option Shuffling : Yes Display Question Number : Yes
Single Line Question Option : No Option Orientation : Vertical

Correct Marks : 1 Wrong Marks : 0

At a slip of 4 %, the maximum possible speed of a 3-phase, 50 Hz, squirrel cage induction motor is

Options :

1. 2880 rpm

2. 3000 rpm

3. 1500 rpm

4. 1440 rpm

Question Number : 41 Question Id : 3909005801 Question Type : MCQ Option Shuffling : Yes Display Question Number : Yes
Single Line Question Option : No Option Orientation : Vertical
Correct Marks : 1 Wrong Marks : 0

In a 3-phase induction motor, speeds higher than the synchronous speed can be obtained by

Options :

1. Variation of supply voltage
2. Rotor slip power control
3. Variation of supply frequency
4. Variation of rotor resistance

Question Number : 42 Question Id : 3909005802 Question Type : MCQ Option Shuffling : Yes Display Question Number : Yes
Single Line Question Option : No Option Orientation : Vertical
Correct Marks : 1 Wrong Marks : 0

A D.C. shunt motor running at 1200 rpm, when excited with 220 V dc. Neglecting losses and saturation, the speed of the motor when connected to a 175 V dc supply is:

Options :

1. 750 rpm
2. 900 rpm
3. 1050 rpm
4. 1200 rpm

Question Number : 43 Question Id : 3909005803 Question Type : MCQ Option Shuffling : Yes Display Question Number : Yes
Single Line Question Option : No Option Orientation : Vertical
Correct Marks : 1 Wrong Marks : 0

The low voltage winding of a 400/230 V, single phase, 50 Hz transformer is to be connected to a 25 Hz supply. The supply voltage should be:

Options :

1. 230 V
2. 460 V
3. 115 V
4. 400 V

Question Number : 44 Question Id : 3909005804 Question Type : MCQ Option Shuffling : Yes Display Question Number : Yes
Single Line Question Option : No Option Orientation : Vertical

Correct Marks : 1 Wrong Marks : 0

The armature of a single phase alternator is wound with T single turn coils distributed uniformly. The induced voltage in each turn is 2 Volts (rms). The emf of the whole winding is:

Options :

1. 2 T Volts
2. 1.11 T Volts
3. 1.414 T Volts
4. 1.273 T Volts

Question Number : 45 Question Id : 3909005805 Question Type : MCQ Option Shuffling : Yes Display Question Number : Yes
Single Line Question Option : No Option Orientation : Vertical

Correct Marks : 1 Wrong Marks : 0

In an induction motor, if the air gap is increased, then

Options :

1. Speed will decrease
2. Efficiency will improve

3. Power factor will be lower

4. Speed will increase

Question Number : 46 Question Id : 3909005806 Question Type : MCQ Option Shuffling : Yes Display Question Number : Yes
Single Line Question Option : No Option Orientation : Vertical

Correct Marks : 1 Wrong Marks : 0

When supply voltage to an Induction motor is reduced by 10%, the maximum torque will decrease by approximately

Options :

1. 5 %

2. 10 %

3. 20 %

4. 40 %

Question Number : 47 Question Id : 3909005807 Question Type : MCQ Option Shuffling : Yes Display Question Number : Yes
Single Line Question Option : No Option Orientation : Vertical

Correct Marks : 1 Wrong Marks : 0

A cable has the following characteristics. $L = 0.2 \mu\text{H/m}$ and $C = 2000 \text{ pF/m}$. The velocity of wave propagation through the cable is

Options :

1. 50 m/s

2. 50 m/ms

3. 50 m/ μs

4. 50 m/ns

Question Number : 48 Question Id : 3909005808 Question Type : MCQ Option Shuffling : Yes Display Question Number : Yes
Single Line Question Option : No Option Orientation : Vertical

Correct Marks : 1 Wrong Marks : 0

If the fault current is 2000 A, the relay setting is 50% and CT ratio is 400:5, the plug setting multiplier will be:

Options :

1. 10 A
2. 15 A
3. 25 A
4. 50 A

Question Number : 49 Question Id : 3909005809 Question Type : MCQ Option Shuffling : Yes Display Question Number : Yes
Single Line Question Option : No Option Orientation : Vertical

Correct Marks : 1 Wrong Marks : 0

The inductance of a power transmission line increases with

Options :

1. decrease in line length
2. increase in diameter of the conductor
3. increase in load current carried by the conductor
4. increase in spacing between the phase conductors

Question Number : 50 Question Id : 3909005810 Question Type : MCQ Option Shuffling : Yes Display Question Number : Yes
Single Line Question Option : No Option Orientation : Vertical

Correct Marks : 1 Wrong Marks : 0

Current chopping tendency can be minimized in SF₆ circuit breakers

Options :

1. by using the gas at higher pressure at high velocity.
2. by using the gas at lower velocity and pressure.

3. by using the gas at higher velocity at low pressure.

4. if the dielectric strength of the original gas can be maintained.

Question Number : 51 Question Id : 3909005811 Question Type : MCQ Option Shuffling : Yes Display Question Number : Yes
Single Line Question Option : No Option Orientation : Vertical

Correct Marks : 1 Wrong Marks : 0

Which of the following relay is directional in nature?

Options :

1. Mho relay
2. Over current relay
3. Reactance relay
4. Impedance relay

Question Number : 52 Question Id : 3909005812 Question Type : MCQ Option Shuffling : Yes Display Question Number : Yes
Single Line Question Option : No Option Orientation : Vertical

Correct Marks : 1 Wrong Marks : 0

In power systems which of the following influence least in its stability?

Options :

1. Individual machine's inertia constants
2. The power carrying capacity of transmission line connecting the machine
3. The real and reactive power losses of the system
4. Excitation system of the machine

Question Number : 53 Question Id : 3909005813 Question Type : MCQ Option Shuffling : Yes Display Question Number : Yes
Single Line Question Option : No Option Orientation : Vertical

Correct Marks : 1 Wrong Marks : 0

The steady-state stability limit of a synchronous generator can be increased by

Options :

1. An increase in its reactance
2. An increase in the excitation of the machine
3. A decrease in the moment of inertia of the machine
4. An increase in the moment of inertia of the machine

Question Number : 54 Question Id : 3909005814 Question Type : MCQ Option Shuffling : Yes Display Question Number : Yes
Single Line Question Option : No Option Orientation : Vertical

Correct Marks : 1 Wrong Marks : 0

In load flow study, the quantities usually specified at the load bus are

Options :

1. V and δ
2. P and V
3. Q and V
4. P and Q

Question Number : 55 Question Id : 3909005815 Question Type : MCQ Option Shuffling : Yes Display Question Number : Yes
Single Line Question Option : No Option Orientation : Vertical

Correct Marks : 1 Wrong Marks : 0

A 50 kM, 50 Hz transmission line is under the category / categories of

Options :

1. Long line only
2. Medium line only
3. Short line only
4. Medium and long lines

Question Number : 56 Question Id : 3909005816 Question Type : MCQ Option Shuffling : Yes Display Question Number : Yes
Single Line Question Option : No Option Orientation : Vertical

Correct Marks : 1 Wrong Marks : 0

For a fault at the terminal of a synchronous generator, the fault current is maximum for a

Options :

1. 3-phase fault
2. 3-phase to ground fault
3. line to ground fault
4. line to line fault

Question Number : 57 Question Id : 3909005817 Question Type : MCQ Option Shuffling : Yes Display Question Number : Yes
Single Line Question Option : No Option Orientation : Vertical

Correct Marks : 1 Wrong Marks : 0

Which one of the following statements is not correct for the use of bundled conductors in transmission lines?

Options :

1. Control of voltage gradient
2. Reduction in corona
3. Reduction in radio interference
4. Increase in interference with communication lines

Question Number : 58 Question Id : 3909005818 Question Type : MCQ Option Shuffling : Yes Display Question Number : Yes
Single Line Question Option : No Option Orientation : Vertical

Correct Marks : 1 Wrong Marks : 0

In a HVDC transmission line

Options :

1. It is necessary for the sending end and receiving end to be operated in synchronism.

The effects of inductive and capacitive reactances are greater than in an AC transmission line of the same rating.

2.

There are no effects due to inductive and capacitive reactances

3.

Power transfer capability is limited by stability considerations.

4.

Question Number : 59 Question Id : 3909005819 Question Type : MCQ Option Shuffling : Yes Display Question Number : Yes
Single Line Question Option : No Option Orientation : Vertical

Correct Marks : 1 Wrong Marks : 0

The units of respective transmission line parameters B and C of a transmission line are

Options :

1. mho and mho

1.

2. ohm and ohm

2.

3. mho and ohm

3.

4. ohm and mho

4.

Question Number : 60 Question Id : 3909005820 Question Type : MCQ Option Shuffling : Yes Display Question Number : Yes
Single Line Question Option : No Option Orientation : Vertical

Correct Marks : 1 Wrong Marks : 0

A single phase transmission line is transmitting 1,100 kW power at 11 kV and at unity power factor. If it has a total resistance of 5 Ω , what is the approximate efficiency of the transmission line?

Options :

1. 80 %

1.

2. 85 %

2.

3. 90 %

3.

95 %

4.

Question Number : 61 Question Id : 3909005821 Question Type : MCQ Option Shuffling : Yes Display Question Number : Yes
Single Line Question Option : No Option Orientation : Vertical

Correct Marks : 1 Wrong Marks : 0

The zero-sequence current will not flow in the

Options :

1. L-G fault
2. L-L-G fault
3. L-L fault
4. L-L-L-G fault

Question Number : 62 Question Id : 3909005822 Question Type : MCQ Option Shuffling : Yes Display Question Number : Yes
Single Line Question Option : No Option Orientation : Vertical

Correct Marks : 1 Wrong Marks : 0

If δ is the loss angle of the cable, its power factor is

Options :

1. $\sin \delta$
2. $\cos \delta$
3. independent of δ
4. $\sin 2\delta$

Question Number : 63 Question Id : 3909005823 Question Type : MCQ Option Shuffling : Yes Display Question Number : Yes
Single Line Question Option : No Option Orientation : Vertical

Correct Marks : 1 Wrong Marks : 0

A generator of 250 MVA rating has an inertia constant of 6 MJ/MVA, its inertia constant on 100 MVA base is

Options :

1. 6 MJ/MVA
2. 15 MJ/MVA
3. 2.5 MJ/MVA
4. 10.5 MJ/MVA

Question Number : 64 Question Id : 3909005824 Question Type : MCQ Option Shuffling : Yes Display Question Number : Yes
Single Line Question Option : No Option Orientation : Vertical

Correct Marks : 1 Wrong Marks : 0

A 100 MVA, 11 kV three phase Alternator observes a three phase fault at terminals of it.

If the fault current is 2000 A, the pu value of positive sequence reactance is

Options :

1. 2.62
2. 0.46
3. 1.31
4. 0.92

Question Number : 65 Question Id : 3909005825 Question Type : MCQ Option Shuffling : Yes Display Question Number : Yes
Single Line Question Option : No Option Orientation : Vertical

Correct Marks : 1 Wrong Marks : 0

For a ground fault protection the relay normally preferred is

Options :

1. Plain Impedance relay
2. Directional relay
3. Reactance relay

4. Mho relay

Question Number : 66 Question Id : 3909005826 Question Type : MCQ Option Shuffling : Yes Display Question Number : Yes Single Line Question Option : No Option Orientation : Vertical

Correct Marks : 1 Wrong Marks : 0

In the following block diagram, $G1 = 10/s$, $G2 = 10/(s+1)$, $H1 = s+3$, $H2 = 1$. The overall transfer function is given by:

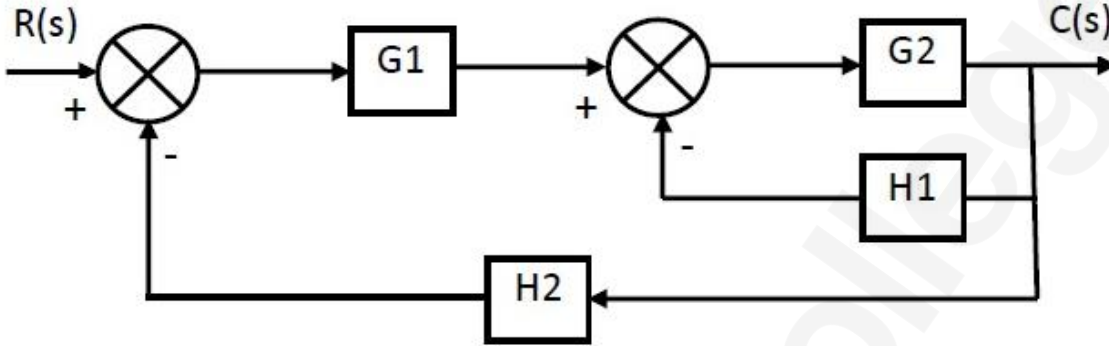

Options :

1. $100/(11s^2+31s+100)$
2. $10/(11s^2+31s+10)$
3. $100/(11s^2+31s+10)$
4. $100/(11s^2+31s)$

Question Number : 67 Question Id : 3909005827 Question Type : MCQ Option Shuffling : Yes Display Question Number : Yes Single Line Question Option : No Option Orientation : Vertical

Correct Marks : 1 Wrong Marks : 0

The closed loop gain of the system shown in the given figure is

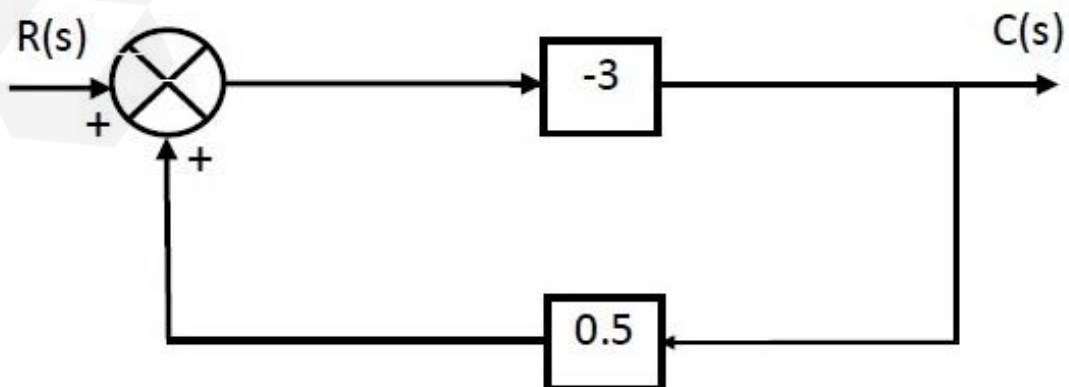

Options :

1. $-9/5$
2. $-6/5$
3. $6/5$
4. $9/5$

Question Number : 68 Question Id : 3909005828 Question Type : MCQ Option Shuffling : Yes Display Question Number : Yes
 Single Line Question Option : No Option Orientation : Vertical
 Correct Marks : 1 Wrong Marks : 0

Use mason's gain formula to find the transfer function of the given signal flow graph:

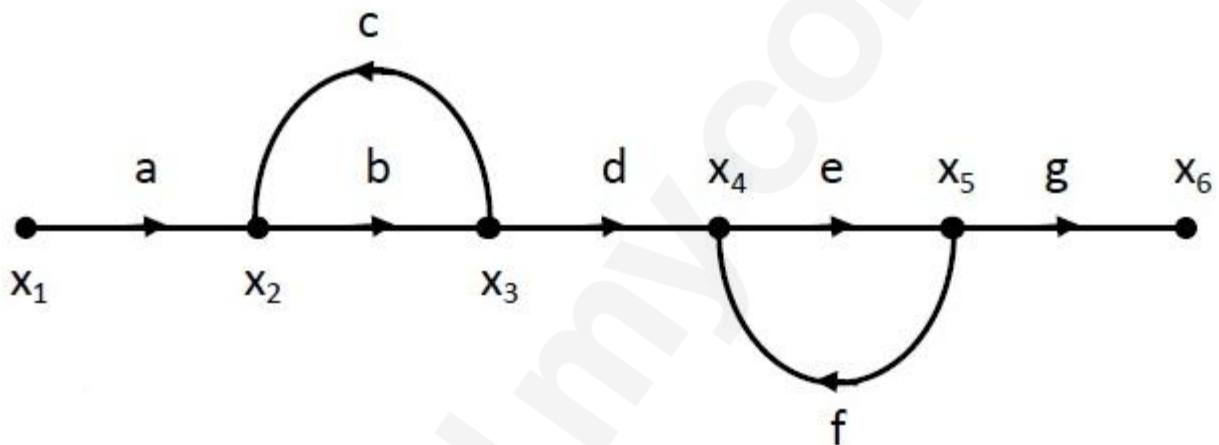

Options :

1. $abd/1-(ac)$
2. $abd/1-(bc+ef)+bcef$
3. $adcdef/1-(bc+ef)+bcef$
4. $abdeg/1-(bc+ef)+bcef$

Question Number : 69 Question Id : 3909005829 Question Type : MCQ Option Shuffling : Yes Display Question Number : Yes
 Single Line Question Option : No Option Orientation : Vertical
 Correct Marks : 1 Wrong Marks : 0

A servomotor is usually designed to have

Options :

1. High rotor inertia and high bearing friction
2. High rotor inertia and low bearing friction
3. Low rotor inertia and high bearing friction
4. Low rotor inertia and low bearing friction

Question Number : 70 Question Id : 3909005830 Question Type : MCQ Option Shuffling : Yes Display Question Number : Yes
Single Line Question Option : No Option Orientation : Vertical

Correct Marks : 1 Wrong Marks : 0

For a feed back control system of Type 2, the steady state error for a ramp input is

Options :

1. infinite
2. constant
3. zero
4. indeterminate

Question Number : 71 Question Id : 3909005831 Question Type : MCQ Option Shuffling : Yes Display Question Number : Yes
Single Line Question Option : No Option Orientation : Vertical

Correct Marks : 1 Wrong Marks : 0

Due to which of the following reasons excessive band width in control systems should be avoided?

Options :

1. It leads to slow speed of response
2. It leads to low relative stability
3. Noise is proportional to bandwidth

4. Presence of feedback

Question Number : 72 Question Id : 3909005832 Question Type : MCQ Option Shuffling : Yes Display Question Number : Yes
Single Line Question Option : No Option Orientation : Vertical

Correct Marks : 1 Wrong Marks : 0

In a stable control system backlash can cause which of the following?

Options :

1. Under damping
2. Over damping
3. Poor stability at reduced values of open loop gain
4. Low-level oscillations

Question Number : 73 Question Id : 3909005833 Question Type : MCQ Option Shuffling : Yes Display Question Number : Yes
Single Line Question Option : No Option Orientation : Vertical

Correct Marks : 1 Wrong Marks : 0

A unit step is applied at $t=0$ to a first order system without time delay. The response has the value of 1.264 units at $t=10$ mins, and 2 units at steady state. The transfer function of the system is

Options :

1. $\frac{3}{(1+600s)}$
2. $\frac{2}{(1+500s)}$
3. $\frac{2}{(1+600s)}$
4. $\frac{5}{(1+220s)}$

Question Number : 74 Question Id : 3909005834 Question Type : MCQ Option Shuffling : Yes Display Question Number : Yes
Single Line Question Option : No Option Orientation : Vertical

Correct Marks : 1 Wrong Marks : 0

The transfer function of the system is $G(s) = 100/(s+1)(s+100)$. For a unit step input to the system the approximate settling time for 2% criterion is:

Options :

1. 100 sec
2. 4 sec
3. 1 sec
4. 0.01 sec

Question Number : 75 Question Id : 3909005835 Question Type : MCQ Option Shuffling : Yes Display Question Number : Yes
Single Line Question Option : No Option Orientation : Vertical

Correct Marks : 1 Wrong Marks : 0

A system with transfer function $1/Ts+1$, subjected to a step input takes t seconds to reach 50% of step height. The value of t is:

Options :

1. 6.9 sec
2. 10 sec
3. 20 sec
4. 14.4 sec

Question Number : 76 Question Id : 3909005836 Question Type : MCQ Option Shuffling : Yes Display Question Number : Yes
Single Line Question Option : No Option Orientation : Vertical

Correct Marks : 1 Wrong Marks : 0

Which of the following transfer function will have the greatest maximum overshoot?

Options :

1. $9/(s^2+2s+9)$
2. $16/(s^2+2s+16)$

3. $25/(s^2+2s+25)$

4. $36/(s^2+2s+36)$

Question Number : 77 Question Id : 3909005837 Question Type : MCQ Option Shuffling : Yes Display Question Number : Yes
Single Line Question Option : No Option Orientation : Vertical

Correct Marks : 1 Wrong Marks : 0

The characteristic equation of a system is given as: $3s^4+10s^3+5s^2+2 = 0$. This system is:

Options :

1. Unstable

2. Stable

3. Marginally stable

4. Oscillatory

Question Number : 78 Question Id : 3909005838 Question Type : MCQ Option Shuffling : Yes Display Question Number : Yes
Single Line Question Option : No Option Orientation : Vertical

Correct Marks : 1 Wrong Marks : 0

The characteristic equation of a system is given as: $s^3+25s^2+10s+50 = 0$. The roots in the right half s-plane and the imaginary axis respectively are

Options :

1. 1,1

2. 0,0

3. 2,1

4. 1,2

Question Number : 79 Question Id : 3909005839 Question Type : MCQ Option Shuffling : Yes Display Question Number : Yes
Single Line Question Option : No Option Orientation : Vertical

Correct Marks : 1 Wrong Marks : 0

A system has poles at 0.01 Hz, 1 Hz and 80 Hz, zeroes at 5 Hz, 100 Hz and 200 Hz. The approximate phase of the system response at 20 Hz is:

Options :

1. 0°
2. -90°
3. 90°
4. -180°

Question Number : 80 Question Id : 3909005840 Question Type : MCQ Option Shuffling : Yes Display Question Number : Yes
Single Line Question Option : No Option Orientation : Vertical

Correct Marks : 1 Wrong Marks : 0

The transfer function of the system described by $\frac{d^2y}{dt^2} + \frac{dy}{dt} = \frac{du}{dt} + 2u$ with u as input and y

as output is :

Options :

1. $\frac{(s+2)}{(s^2+s)}$
2. $\frac{(s+1)}{(s^2+s)}$
3. $\frac{2}{(s^2+s)}$
4. $\frac{2s}{(s^2+s)}$

Question Number : 81 Question Id : 3909005841 Question Type : MCQ Option Shuffling : Yes Display Question Number : Yes
Single Line Question Option : No Option Orientation : Vertical

Correct Marks : 1 Wrong Marks : 0

Consider the unit step response of a unity feedback control system whose open loop

transfer function is $G(s) = \frac{1}{s(s+1)}$. The maximum overshoot is:

Options :

1. 0.143
2. 0.153
3. 0.163
4. 0.173

Question Number : 82 Question Id : 3909005842 Question Type : MCQ Option Shuffling : Yes Display Question Number : Yes
Single Line Question Option : No Option Orientation : Vertical
Correct Marks : 1 Wrong Marks : 0

Bridge balance equation for magnitude in terms of admittances is given by the relation

Options :

1. $Y_1 Y_3 = Y_2 Y_4$
2. $Y_1 Y_2 = Y_3 Y_4$
3. $Y_1 Y_3 = Y_2 Y_3$
4. $Y_1 Y_4 = Y_2 Y_3$

Question Number : 83 Question Id : 3909005843 Question Type : MCQ Option Shuffling : Yes Display Question Number : Yes
Single Line Question Option : No Option Orientation : Vertical
Correct Marks : 1 Wrong Marks : 0

Which of the following types of instruments is an Integrating instrument?

Options :

1. Power factor meter
2. Energy meter

3. Watt meter

4. Frequency meter

Question Number : 84 Question Id : 3909005844 Question Type : MCQ Option Shuffling : Yes Display Question Number : Yes
Single Line Question Option : No Option Orientation : Vertical
Correct Marks : 1 Wrong Marks : 0

An ammeter has a current range of 0 - 5 A, and its internal resistance is 0.02Ω . In order to change the range to 0 - 25 A, a resistance of _____ is to be added.

Options :

1. 0.008Ω in series with the meter

2. 1.0Ω in series with the meter

3. 0.004Ω in parallel with the meter

4. 0.005Ω in parallel with the meter

Question Number : 85 Question Id : 3909005845 Question Type : MCQ Option Shuffling : Yes Display Question Number : Yes
Single Line Question Option : No Option Orientation : Vertical
Correct Marks : 1 Wrong Marks : 0

In a d.c. potentiometer measurements, a second reading is often taken after reversing the polarities of the d.c. supply and the unknown voltage, and the average of the two reading is taken. This is with a view to eliminate the effect of

Options :

1. Ripples in the d.c. supply

2. Stray magnetic fields

3. Stray thermal e.m.f.s

4. Erroneous standardization

Question Number : 86 Question Id : 3909005846 Question Type : MCQ Option Shuffling : Yes Display Question Number : Yes
Single Line Question Option : No Option Orientation : Vertical
Correct Marks : 1 Wrong Marks : 0

Which of the following instruments can be used both for ac and dc measurements?

Options :

1. Moving Iron and PMMC
2. PMMC and Dynamometer
3. Moving Iron and Dynamometer
4. Moving Iron and Induction meter

Question Number : 87 Question Id : 3909005847 Question Type : MCQ Option Shuffling : Yes Display Question Number : Yes
Single Line Question Option : No Option Orientation : Vertical
Correct Marks : 1 Wrong Marks : 0

The meter constant of a single phase, 240 V, Induction Watt hour meter is 400 revolutions per kWh. The speed of the meter disc for a current of 10 A at 0.8 p.f lagging will be

Options :

1. 12.8 rpm
2. 16.02 rpm
3. 18.2 rpm
4. 21.1 rpm

Question Number : 88 Question Id : 3909005848 Question Type : MCQ Option Shuffling : Yes Display Question Number : Yes
Single Line Question Option : No Option Orientation : Vertical
Correct Marks : 1 Wrong Marks : 0

The bridge normally used for measurement of low resistance is

Options :

1. Wheatstone bridge
2. Kelvin's double bridge
3. Maxwell's bridge
4. Schering bridge

Question Number : 89 Question Id : 3909005849 Question Type : MCQ Option Shuffling : Yes Display Question Number : Yes
Single Line Question Option : No Option Orientation : Vertical

Correct Marks : 1 Wrong Marks : 0

When a power BJT is used as power electronic switch, which of the following is true?

Options :

1. It operates in Active and Saturation regions
2. It operates only in Saturation region
3. It operates in Active and Cut-off regions
4. It operates only in Cut-off region

Question Number : 90 Question Id : 3909005850 Question Type : MCQ Option Shuffling : Yes Display Question Number : Yes
Single Line Question Option : No Option Orientation : Vertical

Correct Marks : 1 Wrong Marks : 0

A 32 to 1 multiplexer has the following features

Options :

1. 32 outputs, one input and 5 control signals
2. 32 inputs, one output and 5 control signals
3. 5 inputs, one control signal and 32 outputs

5 inputs, 32 control signals and one output

4.

Question Number : 91 Question Id : 3909005851 Question Type : MCQ Option Shuffling : Yes Display Question Number : Yes
Single Line Question Option : No Option Orientation : Vertical

Correct Marks : 1 Wrong Marks : 0

Calculate the conversion time of a 12-bit counter type ADC with 1MHz clock frequency to convert a full scale input?

Options :

1. 4.095 ms

2. 4.095 ns

3. 4.095 μ s

4. 4.095 s

Question Number : 92 Question Id : 3909005852 Question Type : MCQ Option Shuffling : Yes Display Question Number : Yes
Single Line Question Option : No Option Orientation : Vertical

Correct Marks : 1 Wrong Marks : 0

A 12 bit dual ramp generation has a maximum output voltage of +12 V. Compute the equivalent digital number for the analog signal of +6 V.

Options :

1. 1000000000

2. 10000000000

3. 1000000000000

4. 100000000000

Question Number : 93 Question Id : 3909005853 Question Type : MCQ Option Shuffling : Yes Display Question Number : Yes
Single Line Question Option : No Option Orientation : Vertical

Correct Marks : 1 Wrong Marks : 0

In 8085 microprocessors, how many interrupts are maskable?

Options :

1. Two
2. Three
3. Four
4. Five

Question Number : 94 Question Id : 3909005854 Question Type : MCQ Option Shuffling : Yes Display Question Number : Yes
Single Line Question Option : No Option Orientation : Vertical

Correct Marks : 1 Wrong Marks : 0

The contents of the accumulator in an 8085 microprocessor is altered after the execution of the instruction

Options :

1. ANI 5C
2. CMPC
3. CPI 3A
4. ORA A

Question Number : 95 Question Id : 3909005855 Question Type : MCQ Option Shuffling : Yes Display Question Number : Yes
Single Line Question Option : No Option Orientation : Vertical

Correct Marks : 1 Wrong Marks : 0

For a power transistor, if the forward current gain $\alpha = 0.97$, then $\beta = ?$

Options :

1. 0.03
2. 2.03
3. 49.24

4. 32.33

Question Number : 96 Question Id : 3909005856 Question Type : MCQ Option Shuffling : Yes Display Question Number : Yes
Single Line Question Option : No Option Orientation : Vertical

Correct Marks : 1 Wrong Marks : 0

For a MOSFET $V_{gs} = 3V$, $I_{dss} = 5A$, and $I_d = 2A$. Find the pinch of voltage V_p

Options :

1. 4.08 V
2. 8.16 V
3. 16.32 V
4. 0 V

Question Number : 97 Question Id : 3909005857 Question Type : MCQ Option Shuffling : Yes Display Question Number : Yes
Single Line Question Option : No Option Orientation : Vertical

Correct Marks : 1 Wrong Marks : 0

If a separately excited dc motor is to be operated in the first quadrant only, the converter used is

Options :

1. Single phase semi converter
2. Single phase full wave converter
3. Single phase dual converter
4. Four quadrant chopper

Question Number : 98 Question Id : 3909005858 Question Type : MCQ Option Shuffling : Yes Display Question Number : Yes
Single Line Question Option : No Option Orientation : Vertical

Correct Marks : 1 Wrong Marks : 0

A single phase full wave mid-point converter uses a 230/200 V transformer with centre tap on secondary side. The P.I.V per thyristor is

Options :

1. 100 V
2. 141.4 V
3. 200 V
4. 282.8 V

Question Number : 99 Question Id : 3909005859 Question Type : MCQ Option Shuffling : Yes Display Question Number : Yes
Single Line Question Option : No Option Orientation : Vertical

Correct Marks : 1 Wrong Marks : 0

In a step down chopper, if $V_s = 100$ V and the chopper is operated at a duty cycle of 75 %, find the output voltage.

Options :

1. 100 V
2. 75 V
3. 50 V
4. 25 V

Question Number : 100 Question Id : 3909005860 Question Type : MCQ Option Shuffling : Yes Display Question Number : Yes
Single Line Question Option : No Option Orientation : Vertical

Correct Marks : 1 Wrong Marks : 0

During regenerative braking operation of a chopper based dc drive, the energy transfer takes place

Options :

1. from the load at high voltage to the source at low voltage
2. from the source at high voltage to the load at low voltage
3. from the source at low voltage to the load at high voltage
4. from the load at low voltage to the source at high voltage

Question Number : 101 Question Id : 3909005861 Question Type : MCQ Option Shuffling : Yes Display Question Number : Yes
Single Line Question Option : No Option Orientation : Vertical

Correct Marks : 1 Wrong Marks : 0

In a dual converter, the circulating current

Options :

1. Allows smooth reversal of load current, but increases the response time
2. Does not allow smooth reversal of load current, but reduces the response time
3. Allows smooth reversal of load current with improved speed of response
4. Flows only if there is no interconnecting inductor

Question Number : 102 Question Id : 3909005862 Question Type : MCQ Option Shuffling : Yes Display Question Number : Yes
Single Line Question Option : No Option Orientation : Vertical

Correct Marks : 1 Wrong Marks : 0

For thyristors, pulse triggering is preferred to dc triggering because

Options :

1. Gate dissipation is low
2. Pulse system is simpler
3. Triggering system is required for a very short duration
4. DC triggering consumes more power

Question Number : 103 Question Id : 3909005863 Question Type : MCQ Option Shuffling : Yes Display Question Number : Yes
Single Line Question Option : No Option Orientation : Vertical

Correct Marks : 1 Wrong Marks : 0

In a thyristor, ratio of latching current to holding current is

Options :

1. Between 0.1 and 0.5
2. Between 0.5 and 1.0
3. More than 1.0

4. Equal to 1.0

Question Number : 104 Question Id : 3909005864 Question Type : MCQ Option Shuffling : Yes Display Question Number : Yes
Single Line Question Option : No Option Orientation : Vertical

Correct Marks : 1 Wrong Marks : 0

In a GTO, anode current begins to fall when gate current is

Options :

1. Negative peak at time $t = \text{storage time } t_s$

2. Negative peak at time $t = 0$

3. Just begins to become negative at $t = 0$

4. After passing through current zero

Question Number : 105 Question Id : 3909005865 Question Type : MCQ Option Shuffling : Yes Display Question Number : Yes
Single Line Question Option : No Option Orientation : Vertical

Correct Marks : 1 Wrong Marks : 0

In a three phase dual converter, converter 1 is operating with $\alpha_1 = 95^\circ$ and converter 2 is operating with $\alpha_2 = 85^\circ$. Choose the correct statement.

Options :

1. Converter 1 is operating as a rectifier and converter 2 as an inverter

2. Both the converters are operating as a rectifier

3. Both the converters are operating as an inverter

4. Converter 1 is operating as an inverter and converter 2 as a rectifier

Question Number : 106 Question Id : 3909005866 Question Type : MCQ Option Shuffling : Yes Display Question Number : Yes
Single Line Question Option : No Option Orientation : Vertical

Correct Marks : 1 Wrong Marks : 0

The average gate power dissipation for an SCR is 0.5 Watts, the voltage applied to the gate is $V_g = 10 \text{ V}$. What is the maximum value of gate current I_g for safe operation?

Options :

1. 0.25 A

2. 10 A
3. 0.05 A
4. 0.1 A

Question Number : 107 Question Id : 3909005867 Question Type : MCQ Option Shuffling : Yes Display Question Number : Yes Single Line Question Option : No Option Orientation : Vertical

Correct Marks : 1 Wrong Marks : 0

In case of a constant frequency system, $T_{on} = (1/4)T$. If the chopping frequency 2 kHz, find the value of T_{off}

Options :

1. $(1/8)$ ms
2. $(3/8)$ ms
3. $(1/8)$ μ s
4. $(3/8)$ μ s

Question Number : 108 Question Id : 3909005868 Question Type : MCQ Option Shuffling : Yes Display Question Number : Yes Single Line Question Option : No Option Orientation : Vertical

Correct Marks : 1 Wrong Marks : 0

Assume that the op-amp shown below is ideal. The output voltage V_0 is:

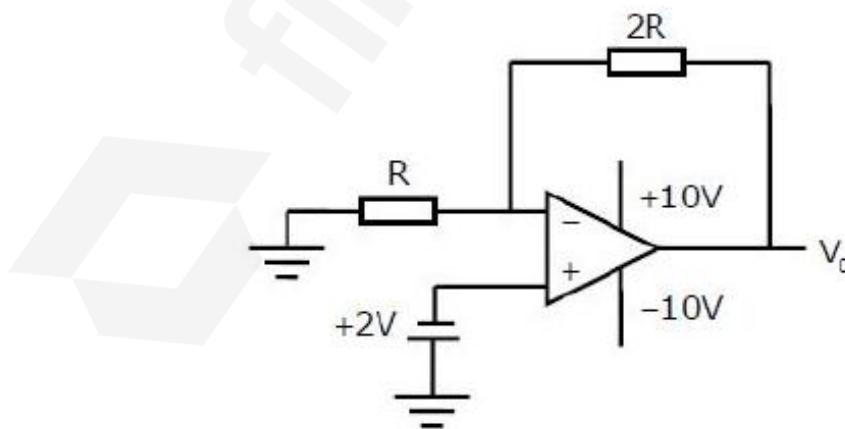

Options :

1. 4 V

2. 6 V
3. 7.5 V
4. 12.12 V

Question Number : 109 Question Id : 3909005869 Question Type : MCQ Option Shuffling : Yes Display Question Number : Yes
Single Line Question Option : No Option Orientation : Vertical

Correct Marks : 1 Wrong Marks : 0

In a sinusoidal oscillator, sustained oscillations will be produced only if the loop gain (at the oscillation frequency) is

Options :

1. Less than unity but not zero
2. Zero
3. Unity
4. Greater than unity

Question Number : 110 Question Id : 3909005870 Question Type : MCQ Option Shuffling : Yes Display Question Number : Yes
Single Line Question Option : No Option Orientation : Vertical

Correct Marks : 1 Wrong Marks : 0

In a BJT amplifier with the introduction of feed-back, the input impedance is reduced, the output impedance is increased, band-width is increased and distortion is reduced.

The feed-back is

Options :

1. Voltage series
2. Current series
3. Voltage shunt
4. Current shunt

Question Number : 111 Question Id : 3909005871 Question Type : MCQ Option Shuffling : Yes Display Question Number : Yes
Single Line Question Option : No Option Orientation : Vertical

Correct Marks : 1 Wrong Marks : 0

The advantage of electric braking is

Options :

1. it is instantaneous
2. more heat is generated during braking
3. motor continue to remain loaded during braking
4. it avoids wear of track

Question Number : 112 Question Id : 3909005872 Question Type : MCQ Option Shuffling : Yes Display Question Number : Yes
Single Line Question Option : No Option Orientation : Vertical

Correct Marks : 1 Wrong Marks : 0

For supply on 25 kV, 50 Hz single phase, suitable motor for electric traction is

Options :

1. dc series motor
2. ac single phase split phase motor
3. ac single phase universal motor
4. dc shunt motor

Question Number : 113 Question Id : 3909005873 Question Type : MCQ Option Shuffling : Yes Display Question Number : Yes
Single Line Question Option : No Option Orientation : Vertical

Correct Marks : 1 Wrong Marks : 0

A train runs at an average speed of 45 kmph between stations 2.5 km apart. The train accelerates at 2 kmph and retards at 3 kmph. Speed-time curve may be assumed to be trapezoidal. The maximum speed attained will be nearly

Options :

1. 50 kmph
2. 60 kmph
3. 70 kmph
4. 80 kmph

Question Number : 114 Question Id : 3909005874 Question Type : MCQ Option Shuffling : Yes Display Question Number : Yes
Single Line Question Option : No Option Orientation : Vertical

Correct Marks : 1 Wrong Marks : 0

Quadrilateral speed-time curve is the closer approximation for

Options :

1. main line service
2. suburban service
3. urban service
4. urban and suburban service

Question Number : 115 Question Id : 3909005875 Question Type : MCQ Option Shuffling : Yes Display Question Number : Yes
Single Line Question Option : No Option Orientation : Vertical

Correct Marks : 1 Wrong Marks : 0

The coefficient of adhesion is

Options :

1. same on ac and dc traction systems
2. high in case of dc traction and low in ac traction
3. low in case of ac traction and high in dc traction
4. high in case of ac traction

Question Number : 116 Question Id : 3909005876 Question Type : MCQ Option Shuffling : Yes Display Question Number : Yes
Single Line Question Option : No Option Orientation : Vertical

Correct Marks : 1 Wrong Marks : 0

Method of speed control used on 25 kV, 50 Hz single phase traction is

Options :

1. Tap changing control of transformer
2. Reduced current method
3. Series parallel operation of motors

4. Reduced voltage method

Question Number : 117 Question Id : 3909005877 Question Type : MCQ Option Shuffling : Yes Display Question Number : Yes
Single Line Question Option : No Option Orientation : Vertical

Correct Marks : 1 Wrong Marks : 0

If the specific energy consumption for suburban services is 50 to 75 watts hours per tonne km, which of the following could be a representative figure for energy consumption on main line service

Options :

1. 150 to 200 watt-hours per tonne km
2. 100 to 125 watt-hours per tonne km
3. 50 to 75 watt-hours per tonne km
4. 20 to 30 watt-hours per tonne km

Question Number : 118 Question Id : 3909005878 Question Type : MCQ Option Shuffling : Yes Display Question Number : Yes
Single Line Question Option : No Option Orientation : Vertical

Correct Marks : 1 Wrong Marks : 0

Induction heating takes place in

Options :

1. conducting but non-magnetic materials
2. conducting materials which may be either magnetic or non-magnetic materials
3. insulating materials
4. conducting and magnetic materials

Question Number : 119 Question Id : 3909005879 Question Type : MCQ Option Shuffling : Yes Display Question Number : Yes
Single Line Question Option : No Option Orientation : Vertical

Correct Marks : 1 Wrong Marks : 0

In induction heating, the depth up to which current will penetrate is proportional to

Options :

1. Frequency
2. $(\text{Frequency})^2$
3. $1/\sqrt{(\text{Frequency})}$
4. $1/(\text{Frequency})$

Question Number : 120 Question Id : 3909005880 Question Type : MCQ Option Shuffling : Yes Display Question Number : Yes
Single Line Question Option : No Option Orientation : Vertical

Correct Marks : 1 Wrong Marks : 0

The illumination is directly proportional to the cosine of the angle made by the normal to the illuminated surface with the direction of the incident flux. Above statement is associated with

Options :

1. Planck's law
2. Macbeth's law of illumination
3. Bunsen's law of illumination
4. Lambert's cosine law