

**A**  
**SET**

Booklet No. :

**NT - 16****Nano Technology**

Duration of Test : 2 Hours

Max. Marks : 120

Hall Ticket No.

--	--	--	--	--	--	--	--	--	--

Name of the Candidate : \_\_\_\_\_

Date of Examination : \_\_\_\_\_

OMR Answer Sheet No. : \_\_\_\_\_

Signature of the Candidate

Signature of the Invigilator

**INSTRUCTIONS**

1. This Question Booklet consists of 120 multiple choice objective type questions to be answered in 120 minutes.
2. Every question in this booklet has 4 choices marked (A), (B), (C) and (D) for its answer.
3. Each question carries **one** mark. There are no negative marks for wrong answers.
4. This Booklet consists of 16 pages. Any discrepancy or any defect is found, the same may be informed to the Invigilator for replacement of Booklet.
5. Answer all the questions on the OMR Answer Sheet using **Blue/Black ball point pen only**.
6. Before answering the questions on the OMR Answer Sheet, please read the instructions printed on the OMR sheet carefully.
7. OMR Answer Sheet should be handed over to the Invigilator before leaving the Examination Hall.
8. Calculators, Pagers, Mobile Phones, etc., are not allowed into the Examination Hall.
9. No part of the Booklet should be detached under any circumstances.
10. The seal of the Booklet should be opened only after signal/bell is given.

NT-16-A



- What is the microstructure of pearlite ?  
(A) Single phase (B) Mixture of austenite and cementite  
(C) Mixture of ferrite and cementite (D) Mixture of austenite and ferrite
- Dimensions of the constant in the Hall-Petch equation is  
(A) MLT (B)  $ML^{0.5}T^{-2}$  (C)  $ML^{-0.5}T^{-2}$  (D)  $MLT^{-2}$
- Crystal structure of austenite is  
(A) BCC (B) FCC (C) BCT (D) HCP
- Tresca Yield criterion is  
(A)  $\sigma_y > (\sigma_1 - \sigma_3)/2$  (B)  $\sigma_y > (\sigma_1 + \sigma_3)/2$   
(C)  $\sigma_y > \sigma_1$  (D)  $\sigma_y > \sigma_3$
- Number of slip systems in FCC is  
(A) 5 (B) 12 (C) 10 (D) 24
- Co-ordination number of atoms in BCC is  
(A) 7 (B) 8 (C) 5 (D) 6
- German silver contains  
(A) 1% silver (B) 2% silver (C) 5% silver (D) no silver
- Which order of formation is correct (which forms first) ?  
(A) Crystal structure>grain structure>microstructure  
(B) Microstructure>grain structure>crystal structure  
(C) Grain structure>microstructure>crystal structure  
(D) Crystal structure>microstructure>grain structure
- If  $x^4 = x^3 + 8$  then x is equal to  
(A) 1 (B) 2 (C) 3 (D) 4
- Normality of a solution is  
(A) Moles/litre (B) Equivalents/litre  
(C) Moles  $\times$  equivalents (D) 2  $\times$  molarity
- In steels, cyaniding is used for  
(A) Hardening (B) Toughening (C) Stiffening (D) Softening

12. Nodular iron is produced by adding which element to cast iron ?  
 (A) Cu (B) Ni (C) Cr (D) Mg
13. If P is number of phases, C is number of components and F is the degrees of freedom then  
 (A)  $P+F+C-2=0$  (B)  $P+F-C-2=0$  (C)  $P-F+C-2=0$  (D)  $P-F-C+2=0$
14. Stacking Fault is a  
 (A) Point Defect (B) Line Defect  
 (C) Surface Defect (D) Volume Defect
15. Burgers vector of a dislocation in FCC is  
 (A)  $[110]$  (B)  $[110]/2$  (C)  $[111]$  (D)  $[111]/2$
16. Which of the following constitutes a slip system in FCC ?  
 (A)  $(111)[1-10]$  (B)  $(111)(110)$  (C)  $(1-11)[1-10]$  (D)  $(110)[111]$
17. Atomic Packing Factor of a simple cubic unit cell is  
 (A) 0.74 (B) 0.69 (C) 0.52 (D) 0.34
18. Charpy test measures which of the following ?  
 (A) Strength (B) Stiffness (C) Ductility (D) Toughness
19. Soft direction for magnetization in iron is  
 (A)  $[100]$  (B)  $[110]$  (C)  $[111]$  (D)  $[123]$
20. In a doped semiconductor if n and p are number of electrons and holes and  $n_i$  the intrinsic charge carrier concentration then  
 (A)  $n = p$  (B)  $np = n_i$  (C)  $np = n_i^2$  (D)  $p = n_i$
21. Time for solidification of a casting of volume V and surface area A is proportional to  
 (A)  $V/A$  (B)  $(V/A)^2$  (C)  $(V/A)^{0.5}$  (D)  $\sqrt{VA}$
22. Energy of a dislocation with burgers vector  $\mathbf{b}$  is proportional to  
 (A)  $b$  (B)  $b^2$  (C)  $b^{0.5}$  (D)  $1/b$
23. Crystal Structure of martensitic steel is  
 (A) FCC (B) BCC (C) SC (D) BCT

24. A vacancy defect in a crystal refers to  
 (A) Missing electron (B) Missing hole  
 (C) Missing atom (D) Missing plane
25. At a pn junction there will be  
 (A) Excess of holes (B) Excess of electrons  
 (C) Excess of dopants (D) Depletion of charge carriers
26. Which steel will you recommend for cryogenic applications ?  
 (A) Ferritic (B) Austenitic (C) Martensitic (D) Bainitic
27. Deformation twins are observed in  
 (A) Cu alloys (B) Al alloys (C) Ni alloys (D) Mg alloys
28. Peierls stress is the stress required for  
 (A) Twinning (B) Moving a dislocation  
 (C) Creating a stacking fault (D) Fracture
29. Diffusion is faster in  
 (A) FCC alloys (B) HCP alloys (C) BCC alloys (D) Compounds
30. The speed of gas particles in a container shows  
 (A) Gaussian distribution (B) Bimodal distribution  
 (C) Maxwell-Boltzmann Distribution (D) Uniform distribution
31. In a regular solution  
 (A) Entropy of mixing is zero  
 (B) Enthalpy of mixing is zero  
 (C) Entropy of mixing is same as that of ideal solution  
 (D) Enthalpy of mixing is same as that of ideal solution
32. Resolution of an optical microscope of numerical aperture NA is  
 (A)  $0.5\lambda/NA$  (B)  $\lambda/NA$  (C)  $\lambda/0.5NA$  (D)  $\lambda^2/NA$
33. Which of the following is not a diffusion controlled process ?  
 (A) Martensitic transformation (B) Solidification  
 (C) Spinodal decomposition (D) Ordering

34. Hardenability is measured in
- (A) Millimetres (B) MPa  
(C) MPa√m (D) It is a dimensionless parameter
35. In a two phase field (eg.  $\alpha + \beta$ ) in a binary alloy
- (A) Composition of the phases changes with alloy composition  
(B) Composition of the phases does not change with alloy composition  
(C) Volume fraction of the phases does not change with alloy composition  
(D) Distribution of phases does not depend on alloy composition
36. For oxide to be protective the Pilling Bedworth ratio should be
- (A)  $<1$  (B) between  $<1$  and  $>2$   
(C)  $>2$  (D) 0
37. Relative permeability  $\mu_r$  for a magnetic material
- (A) is a constant for given material  
(B) changes with applied magnetic field  
(C) does not change with microstructure  
(D) depends on  $\mu_0$
38. Yield strength of an alloy
- (A) does not change on cold working (B) increases on cold working  
(C) decreases on cold working (D) depends on ductility
39. Recrystallization in alloy
- (A) Does not require deformation (B) Requires deformation  
(C) Occurs during solidification (D) Leads to coarse grains
40. Hot working of Al alloys
- (A) frequently leads to recrystallization  
(B) rarely leads to recrystallization  
(C) causes melting  
(D) causes embrittlement
41. Mg alloys are difficult to work
- (A) because they are very strong.  
(B) because they have very limited slip systems.  
(C) because they suffer from grain boundary embrittlement.  
(D) because they are very reactive.
42. Pb-Sn solders are used
- (A) because of their high conductivity. (B) because of their inertness.  
(C) because they form a eutectic. (D) because they readily alloy with Al/Cu.

43. Metals have good thermal conductivity  
 (A) because of their strong bonding.  
 (B) because the bonding is not directional.  
 (C) because of the atoms can vibrate more freely.  
 (D) because electrons help to conduct the heat.
44. On lowering temperature to 0 K a semiconductor  
 (A) Will become a superconductor  
 (B) Stop conducting  
 (C) Will show reduced conductivity  
 (D) Will show improved conductivity
45. An oxide superconductor  
 (A) has higher critical temperature than a metallic superconductor.  
 (B) lower critical magnetic field than a metallic superconductor.  
 (C) is easier to be wound into a solenoid.  
 (D) lower critical electric field than a metallic superconductor.
46. A recording tape has magnetic particles deposited on a flexible polymer. The particles should have  
 (A) low coercivity (B) low permeability  
 (C) low saturation (D) high remanence
47. A recording head is used to convert electrical signals to magnetic signals and record these signals on to a tape. The head should have  
 (A) high coercivity (B) low permeability  
 (C) large saturation (D) high remanence
48. Super conductors are  
 (A) paramagnetic (B) ferromagnetic (C) Diamagnetic (D) ferrimagnetic
49. Piezo electric materials are used to measure  
 (A) change in temperature (B) change in stress  
 (C) change in magnetic field (D) change in humidity
50. Ferroelectric materials are  
 (A) conductors (B) insulators  
 (C) semiconductors (D) superconductors
51. Graphical representations of thermodynamic stability of oxides are called  
 (A) Ellingham diagrams (B) Pourbaix diagrams  
 (C) Shankey diagrams (D) TTT diagrams

52. Seebeck effect is applied in  
 (A) Radiation pyrometry (B) Induction furnaces  
 (C) Thermocouples (D) Laboratory muffle furnaces
53. Consider the equilibrium  $A(g) + B(g) = AB(g)$ . When the partial pressure of A is  $10^{-2}$  atm, the partial pressure of B is  $10^{-5}$  atm and the partial pressure of AB is 1 atm, the equilibrium constant K is  
 (A)  $10 \text{ atm}^{-1}$  (B)  $10^5 \text{ atm}^{-1}$   
 (C) 10 (dimensionless) (D)  $10^5$  (dimensionless)
54. Peritectic reaction in a binary system is given by  
 (A)  $L = \alpha + \beta$  (B)  $\alpha = L + \beta$  (C)  $\gamma = \alpha + \beta$  (D)  $L + \alpha = \beta$
55. If Reynolds number is greater than 1.0 then the  
 (A) viscous force is larger than the inertia force  
 (B) inertia force is larger than the viscous force  
 (C) inertia force is larger than the surface tension force  
 (D) inertia force is larger than the gravitational force
56. Nitrogen content of liquid iron at 1873 K at 1 atm pressure of nitrogen is 0.044 (mass %). What will be the nitrogen content in liquid iron if nitrogen pressure is reduced to 0.25 atm?  
 (A) 0.011 (B) 0.022 (C) 0.088 (D) 0.176
57. The diffusion coefficient of Ni in Cu at 1000 K is  $1.93 \times 10^{-16} \text{ m}^2/\text{s}$  and it is  $1.94 \times 10^{-14} \text{ m}^2/\text{s}$  at 1200 K. The activation energy for diffusion of Ni in Cu is (given  $\log e = 0.4343$ ,  $k = 8.3 \times 10^{-3} \text{ kJ/mol}$ )  
 (A) 130 kJ/mol (B) 180 kJ/mol (C) 230 kJ/mol (D) 300 kJ/mol
58. Contact potential is  
 (A) Difference in Fermi Level (B) Difference in electron mobility  
 (C) Difference in hole concentration (D) Difference in electron concentration
59. Work function of a semiconductor depends on  
 (A) the band gap (B) Width of the conduction band  
 (C) Width of the valence band (D) Fermi level
60. On raising the temperature of a semiconductor  
 (A) the Fermi level changes  
 (B) the number of conduction electrons changes  
 (C) the band gap changes  
 (D) the work function changes

61. In an alloy precipitate free zones form near
- (A) dislocations (B) stacking faults  
(C) grain boundaries (D) vacancies
62. After stress relief annealing
- (A) Grain size of the alloy increases  
(B) Alloy has recrystallized microstructure  
(C) Alloy has lower dislocation density  
(D) Alloy hardness increases
63. Composites are
- (A) Difficult to recycle (B) Difficult to produce  
(C) Difficult to use (D) Difficult to store
64. Fracture stress for a brittle material having a crack length of  $1\ \mu\text{m}$  is 200 MPa. Fracture stress for the same material having a crack length of  $4\ \mu\text{m}$  is
- (A) 50 MPa (B) 100 MPa (C) 25 MPa (D) 75 MPa
65. Which property do we aim to improve in ceramic matrix composites ?
- (A) strength (B) toughness  
(C) corrosion resistance (D) hardness
66. The solvus line in Fe-C diagram is
- (A) Line separating L from L +  $\gamma$   
(B) Line separating L +  $\gamma$  from  $\gamma$  +  $\text{Fe}_3\text{C}$   
(C) Line separating  $\alpha$  from  $\alpha + \beta$   
(D) Line separating L +  $\text{Fe}_3\text{C}$  from  $\gamma$  +  $\text{Fe}_3\text{C}$
67. In fusion welding of alloys, which one is weakest ?
- (A) Base metal (B) Heat affected zone  
(C) Fusion zone (D) Zone showing warping
68. Which dislocation is not confined to a slip plane ?
- (A) Edge (B) Screw (C) Mixed (D) Partial
69. Which of these causes change in grain orientation ?
- (A) Slip (B) Twinning  
(C) Brittle fracture (D) Fatigue Fracture

70. Which of these is likely to show more ductility  
 (A) BCC (B) FCC (C) HCP (D) BCT
71. Which one of the following configuration has the highest fin effectiveness ?  
 (A) Thick closely spaced fins (B) Thin widely spaced fins  
 (C) Thick widely spaced fins (D) Thin closely spaced fins.
72. In a counter flow heat exchanger, hot fluid enters at  $70^{\circ}\text{C}$  and cold fluid leaves at  $40^{\circ}\text{C}$ . Mass flow rate of the hot fluid is  $1\text{ kg/s}$  and that of cold fluid is  $2\text{ kg/s}$ . Specific heat of the hot fluid is  $10\text{ kJ/kgK}$  and that of the cold fluid is  $5\text{ kJ/kgK}$ . The LMTD for the heat exchanger in  $^{\circ}\text{C}$  is  
 (A) 15 (B) 30 (C) 35 (D) 45
73. It is proposed to coat a  $1\text{ mm}$  diameter wire with enamel paint ( $k = 0.1\text{ W/mK}$ ) to increase heat transfer with air. If the air side heat transfer coefficient is  $100\text{ W/m}^2\text{K}$ , then optimum thickness of enamel paint should be  
 (A)  $0.25\text{ mm}$  (B)  $1\text{ mm}$  (C)  $0.5\text{ mm}$  (D)  $2\text{ mm}$
74. Water flows over a flat plate, which is heated over the entire length. Which one of the following relationship between the hydrodynamic boundary layer thickness ( $\delta$ ) and the thermal boundary layer thickness ( $\delta_t$ ) is true ?  
 (A)  $\delta > \delta_t$  (B)  $\delta < \delta_t$  (C)  $\delta = \delta_t$  (D) cannot be predicted
75. In radiative heat transfer, a gray surface is one  
 (A) which appears gray to the eye.  
 (B) which has reflectivity equal to zero.  
 (C) whose emissivity is independent of wavelength.  
 (D) which appears equally bright from all directions.
76. Absorptivity of a body will be equal to its emissivity  
 (A) At all temperatures  
 (B) At only one particular temperature  
 (C) When system is under thermal equilibrium  
 (D) At critical temperature
77. Up to the critical radius of insulation  
 (A) Heat loss decreases with addition of insulation  
 (B) Heat loss increases with addition of insulation  
 (C) There occurs a decrease in heat flux  
 (D) Conduction heat loss is more than convection heat loss

78. The thermal diffusivities for gases are generally  
 (A) More than those for liquids (B) Less than those for liquids  
 (C) More than those for solids (D) Dependent on the viscosity
79. The wavelength of the radiation emitted  
 (A) Depends on the temperature only  
 (B) Depends on (temperature)<sup>2</sup>  
 (C) Does not depend on material of body  
 (D) Depends on temperature and material of the body
80. An increase in convective coefficient over a fin  
 (A) Increase effectiveness (B) Decrease effectiveness  
 (C) Does not influence effectiveness (D) Influence only the fin efficiency
81. For a cylindrical rod with uniformly distributed heat sources the thermal gradients  $dt/dr$  at half the radius location will be  
 (A) one-fourth of that at the surface (B) One-half of that at the surface  
 (C) Twice of that at the surface (D) Four times of that at the surface
82. According to Planck's law, the wavelength corresponding to the maximum energy is proportional to  
 (A)  $T^4$  (B)  $T^3$  (C)  $T^2$  (D)  $1/T$
83. The concept of stream function which is based on the principle of continuity is applicable to  
 (A) three-dimensional flow only (B) two-dimensional flow only  
 (C) uniform flow only (D) irrotational flow only
84. The flow in a river during the period of heavy rainfall is  
 (A) steady, uniform, two-dimensional  
 (B) unsteady, uniform, three-dimensional  
 (C) unsteady, non-uniform and three-dimensional  
 (D) steady, non-uniform and three-dimensional
85. The integration of the Euler's equation results in the Bernoulli's equation. The Bernoulli constants for points lying on the same streamline and those which lie on other streamlines will have the same value if the flow is  
 (A) incompressible (B) steady  
 (C) irrotational (D) uniform

86. As the fluid flows along the solid boundary, more and more fluid in the vicinity of the boundary gets retarded. This deceleration of fluid is on account of
- the assumption on fluid being ideal
  - high velocity flow outside the boundary-layer
  - fluid density
  - high velocity gradients exist at and near the boundary
87. Darcy-Weisbach friction factor  $f$  which is a direct measure of resistance to flow in pipes is dependent on
- roughness height, diameter and velocity
  - relative roughness, diameter and viscosity
  - relative roughness, velocity and viscosity
  - roughness height, diameter, velocity and kinematic viscosity
88. Identify the correct combination of statements from the following:
- |                         |                                    |
|-------------------------|------------------------------------|
| 1. geometric similarity | a. is the similarity of forces     |
| 2. kinematic similarity | b. is the similarity of shapes     |
| 3. dynamic similarity   | c. means the similarity of motions |
- (A) 1-a, 2-b, 3-c (B) 1-b, 2-c, 3-a (C) 1-b, 2-a, 3-c (D) 1-c, 2-b, 3-a
89. The resistance experienced by a ship consists of wave resistance and frictional resistance. Identify from the list given the forces which greatly influence the motion of a ship.
- |                  |                    |                   |
|------------------|--------------------|-------------------|
| 1. Inertia force | 2. Surface tension | 3. Pressure force |
| 4. Viscous force | 5. Gravity force   | 6. Elastic force. |
- (A) 2,3,4 (B) 1,2,3 (C) 1,4,5 (D) 4,5,6
90. The parameters which determine the friction factor for turbulent flow in rough pipes are
- Froude number and relative roughness
  - Froude number and Mach number
  - Mach number and relative roughness
  - Reynolds number and relative roughness
91. Water flowing at 4 m/s in a pressure penstock 4500 m long. If the celerity of the pressure wave travelling in the pipe due to the sudden complete closure of a valve at the downstream end is given as 1500 m/s, what is the period of oscillation?
- 12 sec
  - 3 sec
  - 1125 sec
  - 375 sec

92. In order to have a continuous flow through a siphon, no portion of the pipe be higher than \_\_\_\_\_ measured above the hydraulic grade line.  
 (A) 5.5 m      (B) 10 m      (C) 7.75 m      (D) 10.33 m
93. Mercury differential manometer used for measuring pressure differences across a venturimeter in water pipeline, if an error of 2 mm has been made in observing a differential head of 10 mm, the percentage error in pressure difference is:  
 (A) 20      (B) 5      (C) 10      (D) 2
94. The existence of velocity potential in fluid-flow indicates that  
 (A) the flow must be irrotational  
 (B) the flow is rotational and satisfies the continuity equation  
 (C) the vorticity must be zero  
 (D) the flow is uniform
95. The essential feature of a turbulent flow is  
 (A) large discharge  
 (B) velocity and pressure at a point exhibit irregular fluctuations of high frequency  
 (C) high velocity  
 (D) velocity at a point remains constant with time
96. A particle moving along a circle with variable angular speed will have  
 (A) tangential component of acceleration only  
 (B) normal component of acceleration only  
 (C) no acceleration  
 (D) both tangential and normal components of acceleration
97. For a rotating body, mass moment of inertia is  $10 \text{ Kg-m}^2$  and angular speed is  $3 \text{ rad/s}$ , then kinetic energy is  
 (A) 45 Nm      (B) 20 Nm      (C) 30 Nm      (D) 90 N-m
98. Determine the magnitude of the resultant force of  $F_1 = (5i - 10j + 2k) \text{ kN}$  and  $F_2 = (6j + 3k) \text{ kN}$ .  
 (A) 7.27 kN      (B) 8.12 kN      (C) 9 kN      (D) 17.5 kN

99. The centre of mass for a system of particles will coincide with that of centre of gravity if
- the density of all the particles is same
  - the acceleration due to gravity of all the particles is same
  - the acceleration due to gravity of the particles varies linearly
  - the density of the particles varies linearly
100. A square area of one quarter of a square sheet is cut from the corner as shown in the figure. Determine the centre of gravity of shaded area.
- $5a/4$
  - $5a/6$
  - $5a/8$
  - $5a/12$

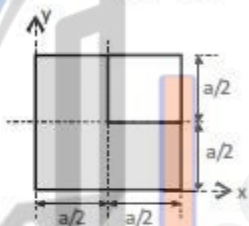

101. Determine the moment of inertia for the section shown in the figure about its y-y axis
- 101.5
  - 102.5
  - 106.83
  - 110.5

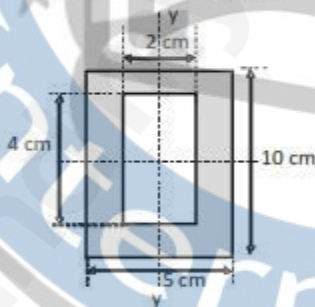

102. The mass moment of inertia of a homogeneous sphere of radius  $R$  about its diameter is
- $3mR^2/5$
  - $2mR^2/5$
  - $4mR^2/5$
  - $5mR^2/4$
103. What is the mass moment of inertia of a cylinder of radius  $R$  about its longitudinal axis if the mass of the cylinder is  $m$ ?
- $mR^2$
  - $mR^2/2$
  - $2mR^2/3$
  - $2mR^2/5$

104. A particle moves in a straight line such that its velocity is defined by  $v = (3t^2 + 2t)$  m/s, where  $t$  is in seconds. Determine its position when  $t=3$  seconds. The initial displacement is zero.

- (A) 12 m      (B) 24 m      (C) 36 m      (D) 48 m

105. The displacement of a particle following simple harmonic motion is given by  $x=2 \cos 20 t$ . What is its period of oscillation ?

- (A)  $\pi/10$       (B)  $\pi/20$       (C)  $\pi/5$       (D)  $2\pi$

106. A wooden block of 5.25 N weight is fired with a bullet of 0.25 N weight at a velocity of 176 m/s and it gets embedded into the block. Find the velocity of bullet and block together after the impact.

- (A) 2 m/s      (B) 4 m/s      (C) 8 m/s      (D) 10 m/s

107. According to the principle of angular momentum, the rate of change of angular momentum of a rotating body with respect to its fixed axis of rotation is equal to

- (A) resultant of all external forces acting on the body.  
 (B) moment of all external forces acting on the body with respect to any axis.  
 (C) moment of all external forces acting on the body with respect to the same axis.  
 (D) Any of the above.

108. The area under the stress – strain curve (up to elastic limit) gives

- (A) strain energy      (B) strain energy per unit volume  
 (C) modulus of elasticity      (D) Bulk modulus

109. The shape of Bending moment diagram for a cantilever beam subjected to uniformly distributed load consists of

- (A) Rectangle      (B) parabola      (C) cubic curve      (D) triangle

110. The shear force diagram consists of \_\_\_\_\_ in case of triangular loads.

- (A) rectangles      (B) parabola      (C) cubic curve      (D) triangle

111. According to the theory of simple bending, the variation of bending stress across a beam cross section is  
 (A) Linear (B) Zero (C) Parabolic (D) Hyperbolic
112. The ratio of maximum shear stress to mean shear stress of a rectangular cross section of a beam is  
 (A)  $\frac{4}{3}$  (B)  $\frac{3}{2}$  (C) 2 (D)  $\frac{8}{3}$
113. What is the relationship among elastic constants ?  
 (A)  $E = \frac{9KG}{(3K+G)}$  (B)  $E = \frac{3KG}{9K+G}$  (C)  $E = \frac{3KG}{K+3G}$  (D)  $E = \frac{9KG}{K+3G}$
114. The shear stress on a principal plane is \_\_\_\_\_ ( $\sigma_x, \sigma_y$  - stresses in x and y directions)  
 (A)  $(\sigma_x - \sigma_y)/2$  (B)  $(\sigma_x + \sigma_y)/2$  (C)  $(\sigma_x - \sigma_y)$  (D) Zero
115. The radius of a Mohr's circle gives  
 (A) minimum shear stress (B) maximum shear stress  
 (C) maximum normal stress (D) minimum normal stress
116. The variation of shear stress in a circular shaft subjected to torsion is  
 (A) linear (B) parabolic (C) hyperbolic (D) cubic curve
117. Maximum shear stress induced in solid shaft subjected to torque is given by  
 (A)  $\frac{16T}{\pi d^3}$  (B)  $\frac{16T}{\pi d^2}$  (C)  $\frac{16T}{\pi d}$  (D)  $\frac{\pi d}{16T}$
118. The shear stress is maximum on a plane inclined at \_\_\_\_\_ to the given planes of loading in case of bi-axial state of stress.  
 (A) 45 degrees (B) 135 degrees (C) 90 degrees (D) 180 degrees
119. What is the nature of stresses on a beam cross section subjected to pure couple ?  
 (A) Tensile (B) Compressive  
 (C) Both tensile and Compressive (D) Shear stress
120. Find the moment of a force  $F = (5i+6j-4k)$  N acting at a point A (2,1,1) m about the origin in N-m.  
 (A)  $7i+13j-10k$  (B)  $5i+3j-2k$  (C)  $-10i-13j+7k$  (D)  $-10i+13j+7k$

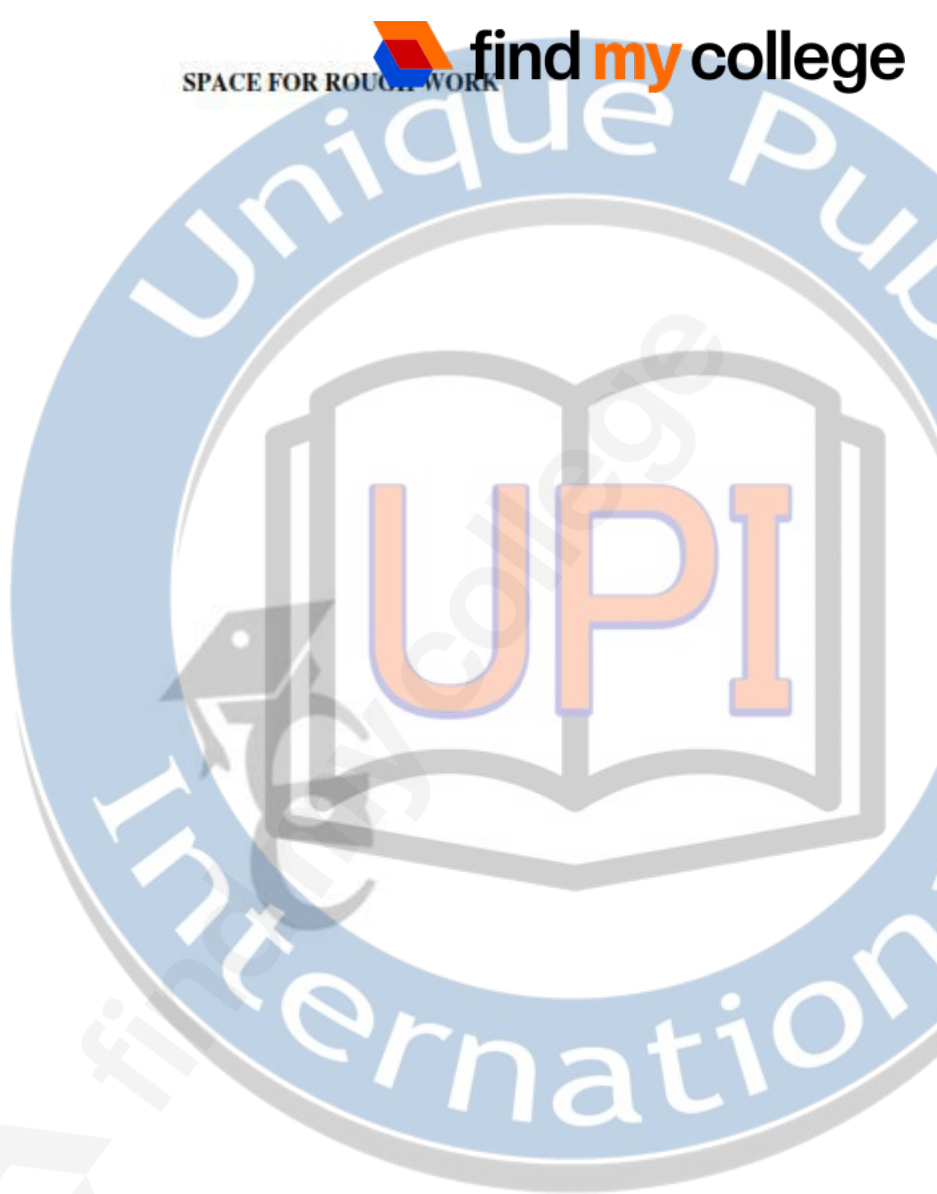

NANO TECHNOLOGY (NT)  
SET-A

Question No	Answer	Question No	Answer
1	C	61	C
2	B	62	C
3	C	63	A
4	A	64	B
5	B	65	B
6	B	66	C
7	D	67	B
8	A	68	B
9	B	69	B
10	B	70	B
11	A	71	D
12	D	72	B
13	B	73	B
14	C	74	A
15	B	75	C
16	A	76	C
17	C	77	B
18	D	78	A
19	A	79	D
20	C	80	B
21	B	81	B
22	B	82	D
23	D	83	B
24	C	84	C
25	D	85	C
26	B	86	D
27	D	87	D
28	B	88	B
29	C	89	C
30	C	90	D
31	C	91	A
32	A	92	C
33	A	93	A
34	A	94	C
35	B	95	B
36	B	96	D
37	B	97	A
38	B	98	B
39	B	99	B
40	A	100	D

41	B	101	A
42	C	102	B
43	D	103	B
44	B	104	C
45	A	105	A
46	D	106	C
47	C	107	C
48	C	108	B
49	B	109	B
50	B	110	B
51	A	111	A
52	C	112	B
53	B	113	A
54	D	114	D
55	B	115	B
56	B	116	A
57	C	117	A
58	A	118	A
59	D	119	C
60	B	120	D

 UPIQPBANK.C